



## Ford Econoline 1992-1996

Visit [MetraOnline.com](http://MetraOnline.com) for more detailed information about the product and up-to-date vehicle specific applications.

### KIT FEATURES

- ISO DDIN radio provision

### KIT COMPONENTS

- A) Radio trim panel • B) Radio brackets • C) Cut template

A

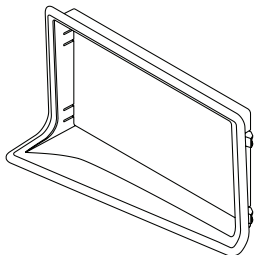

B

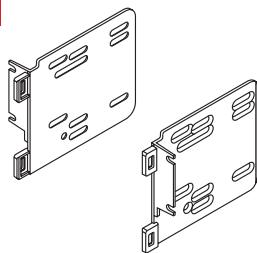

C

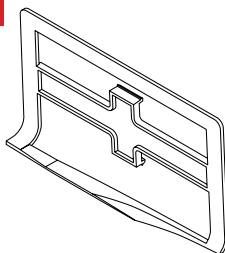

### TABLE OF CONTENTS

Dash Disassembly .....	2
Kit Preparation .....	3
Kit Assembly .....	3

### WIRING & ANTENNA CONNECTIONS

Wire harness: 70-1770 • 70-5510\* (sold separately)

Antenna adapter: Not required

\* Amplified models

### TOOLS REQUIRED

- Cutting tool • Ford radio removal tools\*
- Phillips screwdriver • T-20 Torx screwdriver
- Scribe tool or silver marker

\* Metra part number 86-5618

**Attention!** Let the vehicle sit with the key out of the ignition for a few minutes before removing the factory radio. When testing the aftermarket equipment, ensure that all factory equipment is connected before cycling the key to ignition.

## DASH DISASSEMBLY

1. Remove the knob from the headlight switch by releasing the metal tab on the back of the knob securing it to the shaft. Unscrew and remove the bezel behind it.
2. Remove (2) T-20 Torx screws in the instrument cluster area. The screws are facing up. (Figure A)
3. Remove the trim panels to the left and right of the steering column, then remove (2) T-20 screws exposed from each side. (Figure A)
4. Slide the cup holder out, then remove (2) T-20 screws exposed. (Figure A)
5. Remove (3) T-20 Torx screw securing the lower steering column trim panel, then unclip and remove.
6. Unclip, unplug, and remove the entire dash panel. (Figure A)
7. Using Metra's 86-5618 radio removal tools (sold separately), release the radio from the dash. Slide the radio out, then unplug and remove the radio. (Figure B)

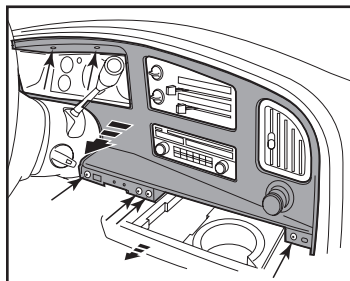

(Figure A)

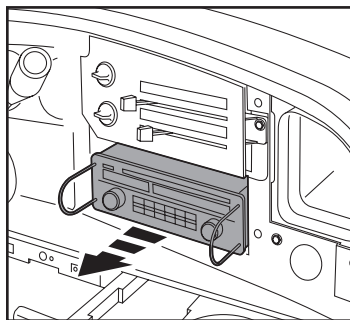

(Figure B)

Continue to Kit Preparation

## KIT PREPARATION

**Attention!** The factory radio will not be able to be reinstalled into the vehicle after these steps have been performed.

### To the factory dash panel:

1. Place the **cut template** over the radio opening from the factory dash panel. (Figure A)
2. Using a scribe tool or silver marker, mark the lines to be cut.
3. Remove and discard the **cut template**, then cut the dash. (Figure B)
4. Attach the **radio trim panel** to the dash. (Figure C)

Continued on the next page

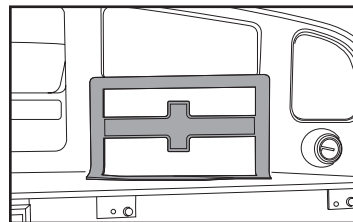

(Figure A)

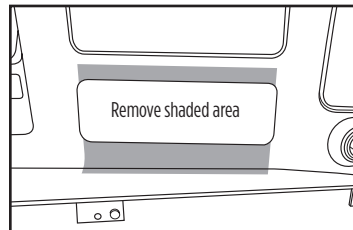

(Figure B)

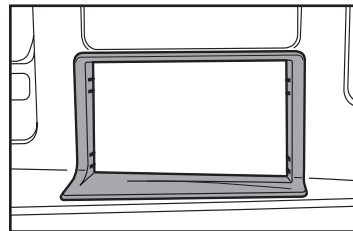

(Figure C)

## KIT PREPARATION *(CONT.)*

### Dash modifications:

5. Cut the sub-dash to allow room for the aftermarket radio. Leave the metal radio support brace in until the point that it must be removed. Leaving that in while cutting will support the sub-dash. (Figure D)

*Continue to Kit Assembly*

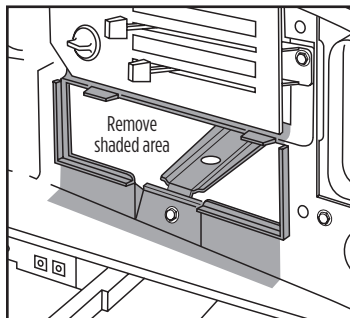

(Figure D)

## KIT ASSEMBLY

1. Secure the **radio brackets** to the radio using the screws supplied with the radio. (Figure A)
2. Locate the factory wiring harness and antenna connector in the dash and complete all necessary connections to the radio. Metra recommends using the proper mating adapter from Metra. Test the radio for proper operation.
3. Slide the radio assembly into the dash, then secure it using the factory screws.
4. Reassemble the dash in reverse order of disassembly to complete the installation.

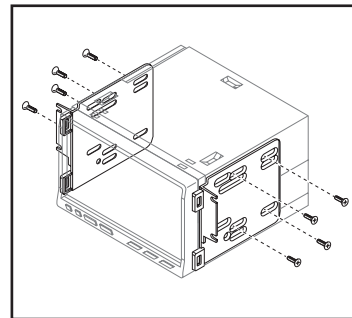

(Figure A)



**95-5704**  
INSTALLATION INSTRUCTIONS



If you are having difficulties with the installation of this product, contact our Tech Support line either by phone at **1-800-253-TECH**, or email at **techsupport@metra-autosound.com**. Before doing so, look over the instruction booklet a second time and ensure that the installation was performed exactly as the instruction booklet is stated. Have the vehicle apart and ready to perform troubleshooting steps before contacting Metra/Axxess Tech Support.



**KNOWLEDGE IS POWER**

Enhance your installation and fabrication skills by enrolling in the most recognized and respected mobile electronics school in our industry. Log onto [www.installerinstitute.com](http://www.installerinstitute.com) or call 800-354-6782 for more information and take steps toward a better tomorrow.



**Metra recommends MECP certified technicians**