

linkT

2-Channel LOC / Line Driver + DSP



Digital Time Alignment • Independent Channel Gain

• 10Vrms Output • OEM Load Detect Compatible

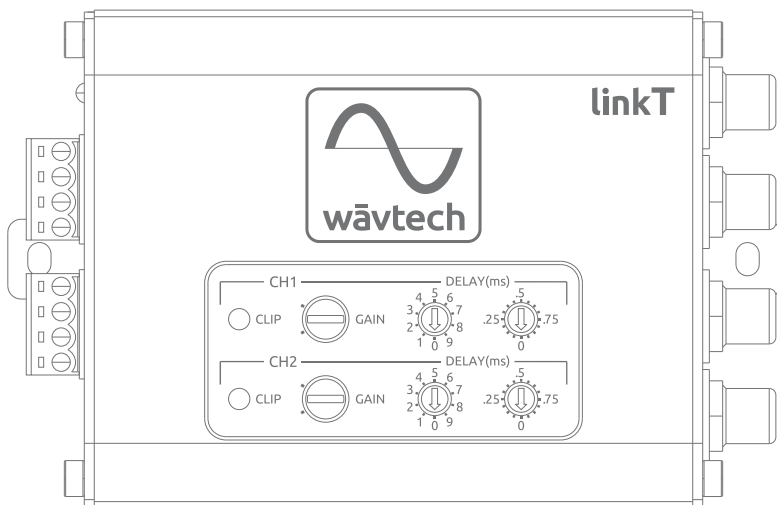
Owner's Manual



www.wavtech-usa.com

 WARNING	This symbol means important instructions. Failure to heed them can result in serious injury or death.
 CAUTION	This symbol means important instructions. Failure to heed them can result in injury or property damages.

WARNING

- **DO NOT DRIVE WHILE DISTRACTED.** Any function that requires your prolonged attention should not be performed while driving. Always stop the vehicle in a safe location before performing any such function. Failure to do so may result in an accident.
- **KEEP THE VOLUME AT MODERATE LEVELS WHILE DRIVING.** Excess volume levels can obscure sounds such as emergency vehicle sirens or road warning signals and may result in an accident. Continuous exposure to high sound pressure levels may cause permanent hearing loss. Use common sense and practice safe sound.
- **FOR USE WITH 12V NEGATIVE GROUND VEHICLE APPLICATIONS ONLY.** Using this product other than in its designed application may result in fire, injury or product damage.
- **MAKE THE CORRECT WIRING CONNECTIONS AND USE PROPER FUSE PROTECTION.** Failure to connect wiring correctly or use appropriate fuse protection may result in fire, injury or product damage. Ensure proper fusing of all system power wiring and install a 1-ampere in-line fuse (not included) with the +12V lead to the unit's power supply connector.
- **DISCONNECT THE NEGATIVE BATTERY TERMINAL BEFORE INSTALLATION.** Failure to do so may result in fire, injury or damage to the unit.
- **DO NOT ALLOW CABLES TO BECOME ENTANGLED IN SURROUNDING OBJECTS.** Arrange wiring and cables to prevent obstructions when driving. Cables or wiring that obstruct or hang up on places such as steering wheel, brake pedals, etc. can be extremely hazardous.
- **DO NOT DAMAGE VEHICLE SYSTEMS OR WIRING WHEN DRILLING HOLES.** When drilling holes in the chassis for installation, take precautions so as not to contact, puncture or obstruct brake lines, fuel lines, fuel tanks, electrical wiring, etc. Failure to take such precautions may result in fire or an accident.
- **DO NOT UTILIZE OR CONNECT TO ANY PART OF VEHICLE SAFETY SYSTEMS.** Bolts, nuts or wires used in the brake, airbag, steering or any other safety-related systems or fuel tanks should NEVER be used for mounting, power or ground connections. Using such parts may disable control of the vehicle or result in fire.

CAUTION

- **STOP USE IMMEDIATELY IF A PROBLEM OCCURS.** Failure to do so may result in personal injury or damage to the product. Return it to your authorized Wävttech dealer.
- **HAVE AN EXPERT DO THE WIRING AND INSTALLATION.** This unit requires special technical skill and experience for wiring and installation. To insure safety and proper function, always contact the authorized dealer where you purchased the product to have it done professionally.
- **INSTALL THE UNIT SECURELY WITH SPECIFIED PARTS.** Be sure to use only the included parts and specified installation accessories (not included). Use of other than designated parts may damage this unit. Install the unit securely so that it will not come loose during a collision or sudden jolt.

- **ROUTE WIRING AWAY FROM SHARP EDGES AND MOVING PARTS.** Arrange cables and wiring away from sharp or pointed edges and avoid moving parts such as seat hinges or rails to prevent pinching or wear. Use loom protection where appropriate and always use a grommet for any wiring routed through metal.
- **NEVER RUN SYSTEM WIRING OUTSIDE OR UNDERNEATH THE VEHICLE.** All wiring must be routed, secured and protected inside the vehicle. Failure to do so may result in fire, injury or property damage.
- **INSTALL THE UNIT IN A DRY AND VENTILATED LOCATION.** Avoid mounting locations where the unit will likely be exposed to high moisture or heat without adequate ventilation. Moisture penetration or heat buildup may result in product failure.
- **REDUCE GAIN AND SOURCE VOLUME TO MINIMUM LEVELS FOR INITIAL SYSTEM TUNING AND BEFORE CONNECTION TO AN AMPLIFIER.** Ensure amplifier power is off before connecting RCA cables and follow proper system gain setting procedures. Failure to do so may result in damage to the amplifier and/or connected components.

Package Contents:

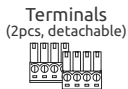
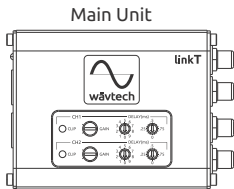

Accessories Required for Installation (not included):

- RCA Interconnects
- 18AWG Wire
- In-line Fuse Holder w/1A fuse
- Battery Ring Terminal
- Ground Terminal
- Wire Crimp Connectors
- Grommets and Loom
- Cable Ties
- Mounting Screws

Introduction

Welcome to Wāvtech, exceptional mobile audio integration products for audiophiles. Our products are engineered to provide a truly remarkable listening experience. Built for the professional installer, our OEM integration and signal processor models are simply the best solution available for unlimited sound system upgrades while retaining the factory receiver.

Features

- 2-Channel Digital Time Alignment Processor
- 2-Channel Line Output Converter or Line Driver
- Differential Balanced Inputs
- Low Impedance Outputs
- Independent Variable Gains with Clip LEDs
- Auto Turn-On via DC-Offset or Audio Signal Detect
- Generated +12V Remote Output
- OEM Load Detect Compatible
- Selectable Ground Isolation
- Detachable Power and Speaker Input Terminals
- Professional Grade Panel Mount RCA Output Jacks
- Aluminum Chassis w/Detachable Mounting Tabs

Connections & Functions

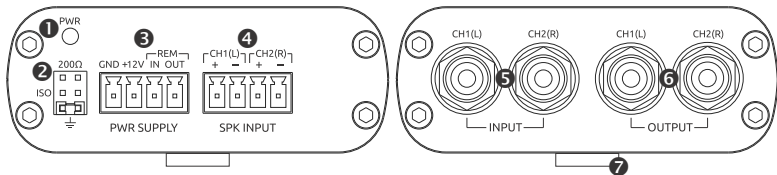

- 1 Power Indicator:** This red LED indicates when the linkT is powered on. Once illuminated, there will be a short delay before audio signal output is enabled. During initial power connection, the LED may illuminate for a brief period.
- 2 Ground Jumper:** For selecting between chassis, isolation or 200Ω for the internal audio signal ground. Chassis ground is the default setting and is ideal for most applications due to the differential input stage. In the rare case there is system noise present after all other installation countermeasures, changing this jumper to ISO or 200Ω may reduce or eliminate the noise.
- 3 Power Supply Terminal:** For +12V battery, chassis ground, remote input and remote output wire connections. A minimum of 18AWG wire is recommended for power and ground connections. Always protect the +12V power wire with a 1-amp fuse.
- 4 Speaker Level Input Terminal:** For left and right channel speaker level (a.k.a. high level) connections to the source. Input signals ranging from 2Vrms to 20Vrms will produce up to 10Vrms RCA output at maximum to minimum gain setting. Dynamic music signal peaks are allowable up to 40Vrms, but will be clipped. Use this input if your source unit does not have RCA outputs.
- 5 RCA Input Jacks:** For left and right channel low level (a.k.a. line level) signal connections to the source unit. Input signals ranging from 0.5Vrms to 5Vrms will produce up to 10Vrms RCA output at maximum to minimum gain setting, individually adjustable per channel.
- 6 RCA Output Jacks:** For left and right channel line level signal connections to your amplifier(s). Use quality interconnects to ensure stable connections and minimize the possibility for induced noise.
- 7 Mounting Tabs:** These mounting tabs are pre-attached and should be used to properly secure the linkT during installation with screws or cable ties. They are removable if the unit can be safely secured by another method.

Installation & System Wiring

It is important to read this manual thoroughly before starting your installation and always plan accordingly. Before installing any Wāvtech product, disconnect the negative (ground) wire from the vehicle's battery to avoid damage to the vehicle or yourself. Following all guidelines will help provide years of enjoyment with your Wāvtech linkT audio interface.

Ground Connection (GND): The GND terminal must be connected to a metal part of the vehicle that is welded to the vehicle body with ground plane back to the main battery ground attachment point (a.k.a. chassis ground). This wire should be a minimum of 18AWG and as short as possible to minimize potential for noise to enter the system. The chassis ground connection point should have all of the paint removed and be scuffed to the bare metal. The ground wire should be terminated by a ground specific interlocking terminal such as the EARL terminal or ring terminal securely bolted to the vehicle with star or lock washer and nut to prevent it from coming loose. Avoid using factory ground points to reduce the chance of induced noise from other components.

Power Connection (+12V): The constant power connection should be made at the vehicle battery when possible. For direct battery connection, a 1-amp fuse must be installed in-line with the power wire within 18" of the battery and securely connected to the positive battery terminal bolt with a ring terminal. If connecting to another available constant +12V power source, a 1-amp in-line fuse must be added at the connection point. The power wire should be a minimum of 18AWG. Do not install the fuse until all other system connections have been made.

Speaker Level Inputs (SPK): Connect the speaker wires from the source unit to the corresponding input terminals at the interface. Always ensure correct polarity of each channel when making these connections, as failure to do so can severely effect sound performance.

Remote Input (REM IN): If the source unit has a remote output wire (provides +12V only when turned on), connect it to the REM IN terminal. If a remote lead is unavailable, the linkT is also enabled with an automatic turn-on circuit that detects audio signal from SPK and RCA inputs, as well as DC-offset from SPK inputs. While auto turn-on will work in most applications, there may be some cases where detection level is not satisfactory and connecting a +12V trigger to REM IN is needed.

Remote Output (REM OUT): Use the remote output to provide a +12V trigger to turn on amplifiers or other components. This +12V output is generated internally by the interface when turned on either by REM IN or automatic sensing, and will provide over 500mA continuous current for external devices.

Top Panel Adjustments

- 1 Clipping Indicators:** These yellow LEDs indicate when the output signal from each channel is at maximum level before clipping (distortion) occurs. Each will be dimly lit just below the onset of clipping, and full bright at clipping.

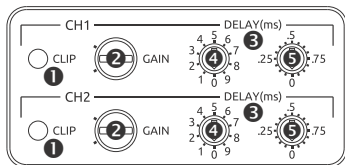

Since the linkT will produce over 10Vrms at full output, gain may need to be reduced well below the point of illumination in order to match your amplifier's maximum input capability or optimize source volume range.

- 2 Gain Adjustments:** These gain adjustments are for matching each channel's output signal level of the linkT with the maximum unclipped signal range from the source and maximum input capability of your amplifier(s). Follow proper gain setting procedures to ensure optimum source volume range with minimum chance for clipping at any point in the signal chain.
- 3 Time Alignment:** These rotary switches are for selecting the amount of time delay applied to CH1 and CH2 outputs. Each channel has two switches, one for milliseconds and another for fractions of a millisecond. These separate digits allow for quick coarse adjustment and simple fine tuning by ear or distance measurement. If adjusting for individual loudspeaker alignment such as between a tweeter and midrange, it is recommended to first start with delay based upon the measured difference in distance to the listening position, then fine tune by ear using a high resolution music track with known instrument placement and staging.

- 4 1st Digit:** This rotary switch provides delay in 1ms increments in 9 steps for up to 9ms. Each step is equivalent to 13.5in (34.3cm) in distance. Use this adjustment for initial coarse delay settings for larger differences to the listening position.
- 5 2nd Digit:** This rotary switch provides delay in 0.0625ms increments in 15 steps for up to 0.94ms. Each step is equivalent to 0.85in (2.1cm). Once the imaging is set close to the desired result with coarse adjustment, or for differences less than 1ms, use this rotary to fine tune imaging and focus.

1st Digit



$$1\text{ms/step} = 13.5\text{in}(34.3\text{cm})$$

2nd Digit



$$0.0625\text{ms/step} = 0.85\text{in}(2.1\text{cm})$$

Example:

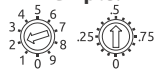

$$2\text{ms} + 0.5\text{ms} = 2.5\text{ms} = 33.75\text{in}(85.75\text{cm})$$

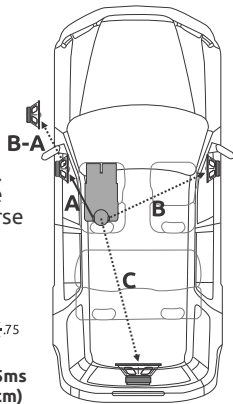

Note: When using the linkT to optimize left/right stereo imaging, delay the closest speaker (A) by the difference between it and the furthest speaker (B) to the listening position (B-A), or simply adjust by ear for desired image placement. If a subwoofer is also present, once stereo imaging is set, both channels can then be further delayed equally by the additional distance from the subwoofer (C-B), or until the perception of up front bass is achieved.

System Examples

Example-1: Speaker Level Input from OEM Radio

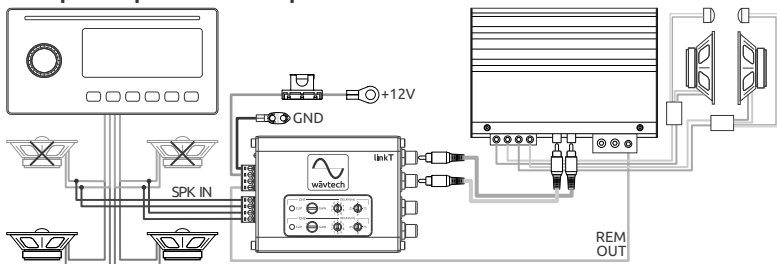

Note: When using a receiver's internal power IC to drive speakers directly and provide the linkT with signal, note that its speaker outputs will likely clip below the maximum master volume level. Adjust gain settings accordingly for optimum unclipped volume range.

Example-2: RCA Input from Aftermarket Radio

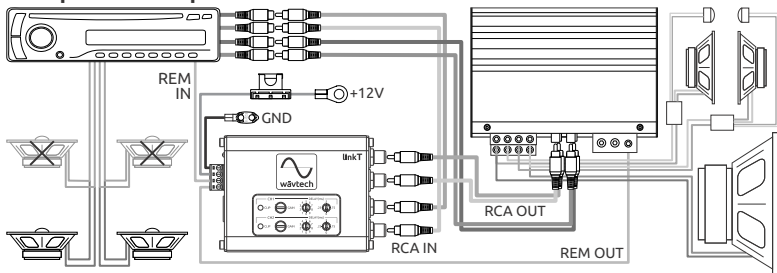

Note: When adding time alignment only for front speakers and retaining deck power to rear speakers, it is recommended to use the fader to reduce rear speaker level enough to provide some ambience while minimizing any affect to front staging and image focus.

Example-3: RCA Input from Portable Audio Player

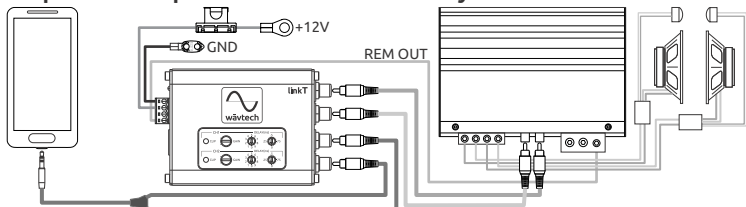

Note: Portable devices such as smartphones or MP3 players typically have an output voltage of 1Vrms or less. While the linkT's auto turn-on circuit will detect very low signal levels, in some cases the gains may need to be adjusted for reduced total volume range when using the portable device as the system master volume control.

Example-4: Multiple Channels & System Expansion

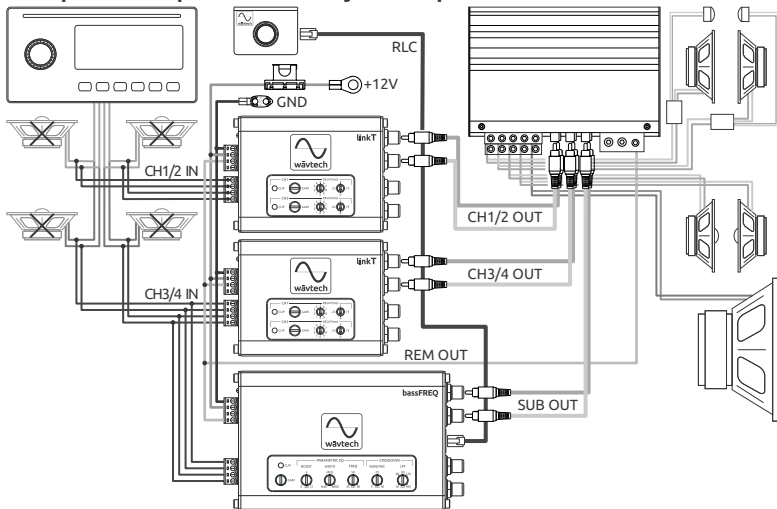

Note: Multiple linkTs can be used for aligning more channels such as front and rear, bi-amped components, or large subwoofer systems. Other Wavtech models can also be added for additional conversion channels and features. In this example, the bassFREQ provides remote level control, parametric EQ and -24dB/oct crossover for a subwoofer.

Example-5: Post Process Time Alignment

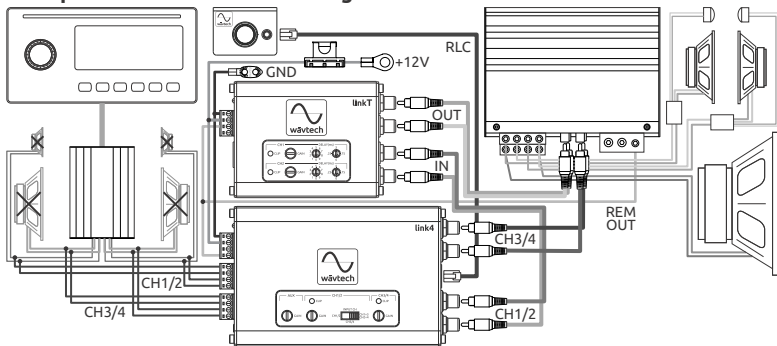

Note: When adding the linkT for time alignment after another Wavtech model such as the link4, adjust the link4's gain to both maximize the linkT's input signal without clipping and match its output with the input capability of the connected amplifier(s).

Specifications

Frequency response	Max Flat (+0/-1dB)		<20Hz to >36kHz
	Extended (+0/-3dB)		<10Hz to >44kHz
Input Impedance	Spk Input		180Ω
	RCA Input		20kΩ
Input Sensitivity	Spk Input (max-min gain)		2 - 20Vrms
	RCA Input (max-min gain)		0.5 - 5Vrms
Max Input Voltage (peak)	Spk Input	<5sec	40Vrms
	RCA Input	<60sec	15Vrms
Output Impedance			<50Ω
Max Output Voltage	at 1% THD+N		>10Vrms
THD+N	Spk Input at 10V output		<0.1%
	RCA Input at 10V output		<0.05%
S/N (signal-to-noise)	Spk Input	at 1V output	>75dBA
		at 4V output	>87dBA
		at 10V output	>95dBA
	RCA Input	at 1V output	>75dBA
		at 4V output	>87dBA
		at 10V output	>95dBA
Time Alignment	Delay Range		9.94ms (11.2ft/3.4m)
	Increments	1 st Digit	1ms (13.5in/34.3cm)
		2 nd Digit	0.0625ms (0.85in/2.1cm)
Turn-On Trigger	Remote	via REM IN	>10.5V
	DC-offset	via Spk Input	>1.3V
	Audio Signal	via Spk Input	<100mV
		via RCA input	<10mV
		Turn-off Delay	up to 60sec
Remote Output	Current Capacity		>500mA
	Voltage		Within 3% of B+
Current Draw	Max Draw (w/o REM OUT)		<300mA
	Sleep Current		<2.3mA
Operating Voltage (B+)	Power On		10.5V-18V
	Power Off		<8.5V
Product Dimensions	Chassis (not incl. terminals)		1.1"x2.9"x3.7"
			29x75x93mm

Note: Specifications are subject to change without notice.

Installation Notes

Vehicle Description

- Year, Make, Model: _____
- Trim Level / Package: _____

OEM Audio System Info

- Head Unit (type, BT/AUX in, etc.): _____
- Speakers (size/location, etc.): _____

- Subwoofer(s) (size/location, etc.): _____
- Amplifier(s) (location, output voltage, etc.): _____

- Other: _____

linkT Connections & Settings

- Installed Location: _____
- Wiring (connection locations, signal type, turn-on mode, etc): _____

- Level Settings (gain position, max master vol, etc.): _____

- Other: _____

System Configuration: _____

System Diagram

Warranty & Service Care

Wävtech warrants this product to be free from defects in material and workmanship for a period of one (1) year when purchased from an authorized Wävtech retailer within the United States. This warranty will be extended to a period of two (2) years when the installation is performed by an authorized Wävtech retailer. A valid sales receipt is required to verify eligibility of purchase and installation.

This warranty is valid only to the original purchaser and is not transferrable to subsequent parties. This warranty is void if the product serial number has been altered or removed. Any applicable implied warranties are limited in duration to a period of express warranty as provided herein beginning with the date of the original purchase at retail, and no warranties, whether expressed or implied, shall apply to this product thereafter. Some states do not allow limitations on implied warranties, therefore these exclusions may not apply to you. This warranty gives you specific legal rights. You may also have other rights which vary from state to state.

If your product needs service, you should contact Wävtech Customer Service to receive a Return Authorization (RA) Number. Any product received without an RA number will be returned to sender. Once your product is received and inspected by customer service, Wävtech at its sole discretion, will be repair or replace it with a new or remanufactured product at no charge. Damage caused by the following is not covered under warranty: accident, abuse, failure to follow instructions, misuse, modification, neglect, unauthorized repair or water damage. This warranty does not cover incidental or consequential damages. This warranty does not cover the cost of removing or reinstalling the product. Cosmetic damage and normal wear are not covered under warranty.

For Service within the United States:

Wävtech Customer Service: (480) 454-7017

Monday – Friday, 8:30am to 5:00pm MST

Serial Number: _____

Installation Date: _____

Place of Purchase: _____

Important Notice for International Customers:

For products purchased outside the United States of America or its Territories, please contact your local distributor concerning specific procedures for your country's warranty policy. International purchases are not covered by Wävtech, LLC.

Wävtech™
7931 E. Pecos Rd
Suite 113
Mesa, AZ 85212
(480) 454-7017

©Copyright 2017 Wävtech, LLC. All Rights Reserved.