



CleanSweep™ CL441 dsp OEM Interface / Processor

owner's manual

*Thank you for purchasing a JL Audio CleanSweep™
OEM interface / processor for your automotive sound system.*

This product has been designed and manufactured to exacting standards in order to ensure years of musical enjoyment in your vehicle. For maximum performance and extended warranty coverage, we highly recommend that you have your CL441dsp installed by an authorized JL Audio dealer. Your authorized dealer has the training, expertise and installation equipment to ensure optimum performance from this product without compromising your vehicle's functionality. Due to the complexity of modern vehicle systems we do not recommend self-installation unless you have extensive experience in automotive electrical systems.

If you have any questions regarding the instructions in this manual or any aspect of the product's operation, please contact your authorized JL Audio dealer for assistance. If you need further assistance, please call the JL Audio Technical Support Department at (954) 443-1100 during business hours (Eastern Time Zone).



SERIAL NUMBER

In the event that your CleanSweep™ CL441dsp requires service or is ever stolen, you will need to have a record of the product's serial number. Please take the time to enter that number in the space provided below. The serial number can be found on the bottom panel of the unit and on the packaging.

Serial Number:

PROTECT YOUR HEARING!

We value you as a long-term customer. For that reason, we urge you to practice restraint in the operation of this product so as not to damage your hearing and that of others in your vehicle. Studies have shown that continuous exposure to high sound pressure levels can lead to permanent (irreparable) hearing loss. Automotive audio systems are capable of producing such high sound pressure levels. Please limit your continuous exposure to high volume levels.

While driving, operate your audio system in a manner that still allows you to hear necessary noises to operate your vehicle safely (horns, sirens, etc.).

INSTALLATION APPLICATIONS

This product is designed for operation in vehicles with 12V, negative-ground electrical systems. Use of this product in vehicles with positive ground and/or voltages other than 12V may result in damage to the product and will void the warranty.

This product is **not** certified or approved for use in aircraft.

PLANNING YOUR INSTALLATION

It is important that you take the time to read this manual and that you plan out your installation carefully.

Safety Considerations:

Your CleanSweep™ needs to be installed in a dry environment and in a manner which does not interfere with your vehicle's safety equipment (air bags, seat belt systems, ABS brake systems, etc.). You should also take the time to securely mount the CleanSweep™ processor so that it does not come loose in the event of a collision or sudden acceleration / deceleration.

Stupid Mistakes to Avoid:

- Check before drilling any holes in your vehicle to make sure that you will not be drilling through a gas tank, brake line, wiring harness or other vital vehicle system.
- Do not run system wiring outside or underneath the vehicle. This is an extremely dangerous practice which can result in severe damage to your vehicle and person.
- Protect all system wires from sharp metal edges and wear by carefully routing them, tying them down and using grommets and loom where appropriate.
- Do not mount this product in the engine compartment, under the vehicle, on the roof or in any other area that will expose it to the elements.

PRODUCT OVERVIEW

The CleanSweep™ CL441dsp is a sophisticated digital audio processor that performs the following functions:

- 1) It accepts virtually any analog audio signal, from low-voltage line-level to high-power, amplified speaker-level, via its four differential-balanced inputs. With totally automatic level compensation, the CL441dsp converts the two or four connected analog signals to digital audio with 24 bit effective resolution.
- 2) The CL441dsp applies its 32-bit SHARC® DSP processor to automatically equalize each of the four channels with 30 bands of equalization (120 bands total), effectively correcting the response of almost any factory-equalized, full-range signal. These digital-domain corrections will range from subtle to dramatic, depending on the degree of equalization engineered into the factory audio system.

To accomplish this complex feat, you simply load the supplied CleanSweep™ Calibration CD into the factory-installed CD player; set its volume control between 1/2 and 3/4 of maximum, play the designated calibration track and then press the "Calibrate" button on the top of the CL441dsp processor. Approximately 20 seconds later, the processor is finished analyzing and equalizing the factory-installed source's response and stores the corrections in non-volatile flash memory.

- 3) The digitally corrected signals are then converted back to analog audio and sent to your aftermarket amplifiers through two pairs of low-distortion, 8 volt (RMS) line-level outputs.
- 4) The CL441dsp provides a simple rotary knob with stops at both ends to control the master system volume at the outputs of the processor unit for the OEM (factory) source and the Auxiliary source. The master volume eliminates the effects of any equalization that is dependent on the OEM volume control position and allows a high signal-to-noise ratio to be maintained in the system. When pressed, the Master Volume Control also selects between the OEM and Auxiliary source. A dash-mountable status LED changes color to indicate OEM or AUX input modes. These small items can be easily mounted within reach of the driver.
- 5) The CL441dsp can be deployed in signal-sensing mode, powering up and providing a 12-volt turn-on signal for aftermarket equipment whenever signal is detected. It can also be activated by a conventional 12-volt trigger, if the OEM system provides one.

POWER CONNECTIONS

Before installing the CL441dsp, disconnect the negative (ground) wire from the vehicle's battery. This will prevent accidental damage to the system, the vehicle and your body during installation.

The CL441dsp has a 4-pin inline jack located next to the line output jacks. This jack accepts the following connections (a wiring harness with a mating plug is included):

“+12 V”: Constant +12V

“GND”: Chassis Ground

“IGN”: Switched +12V

“REM.OUT”: Amplifier turn-on (+12V)

Since the CL441dsp does not draw very much current during operation, 18 AWG - 16 AWG wire is ample for making all of these connections. Use good-quality crimp connectors (or solder and heatshrink tubing) to join the harness leads to any extended wires. Any wires run through metal barriers (such as firewalls), must be protected with a high quality rubber grommet to prevent damage to the insulation of the wire. Failure to do so may result in a dangerous short circuit.

Ideally, the “+12V” (constant) and “GND” (chassis ground) connections should be run to the same distribution points that the amplifiers use for their power and ground connections. This minimizes the possibility of noise in the system.

The “IGN” connection is designed to do the following: the CL441dsp will only turn on when +12V is present at this connection. Conversely, the CL441dsp will shut off as soon as +12V is removed from this connection. We recommend that you connect this wire to a 12 volt circuit in the car that is only energized with the key in the “Accessory” (ACC) or “Ignition” (IGN) positions. Since the CL441dsp is designed to control the rest of the aftermarket system's turn-on and turn-off functions, this will ensure that the audio system will only operate with the key in ACC or IGN positions. See “Signal Sense Modes” section on Page 9 for further options.

The “REM.OUT” (Remote Output) connection provides turn-on voltage to other aftermarket equipment (just like an aftermarket head unit's remote turn-on lead).

FUSE REQUIREMENTS

The +12V constant wire on the CL441dsp power harness has an inline 1 amp, fast blow AGC (small glass-bodied) fuse for protection of the unit. Do not remove this fuse or replace it with a different value of fuse.

OUTPUT CONNECTIONS

Four RCA-type jacks provide four-channels of analog audio output to feed your aftermarket system. These are located next to the “Power Connector” and are clearly labeled for each channel. Think of them as your new head unit outputs.

OUTPUT AND POWER CONNECTION DIAGRAM

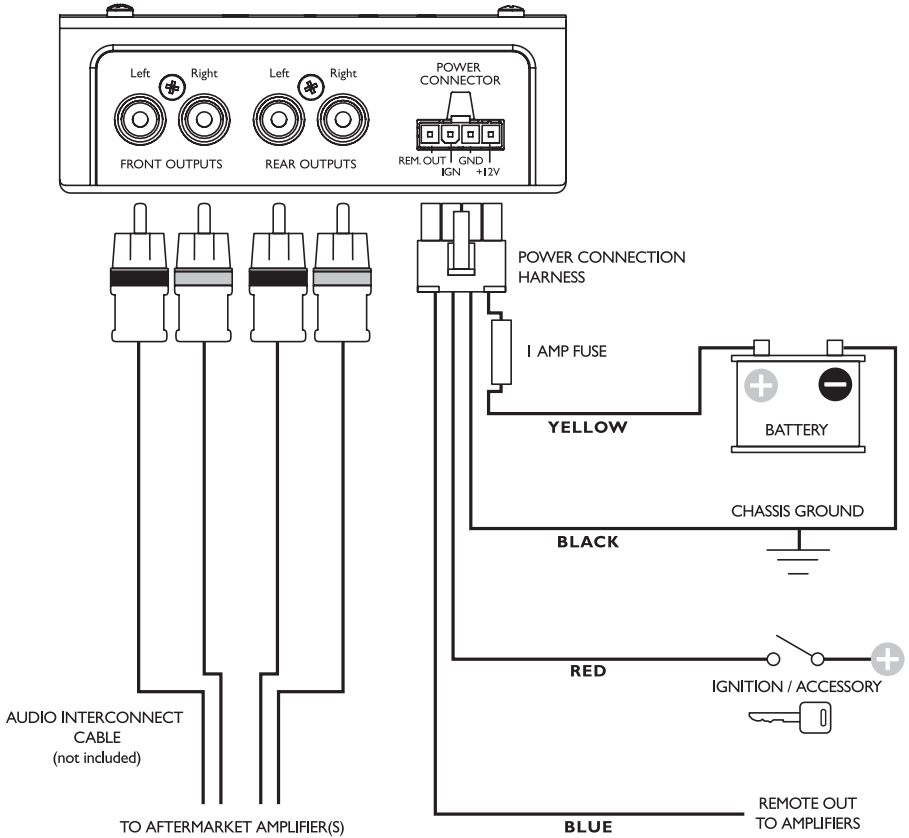

OEM INPUT CONNECTIONS

The CL441dsp accepts up to four channels of input from an OEM audio source via the 8-pin plug located on one end of the main processor. A color-coded harness is included for connection to this 8-pin plug. The input architecture is set up in a differential-balanced configuration, making these inputs compatible with virtually any analog audio signal.

Refer to the wiring diagram on Page 7 for channel and polarity information.

It is vital to observe correct electrical polarity on each channel when making input connections. Failure to do so can result in significant loss of bass and other audible problems.

The CL441dsp can accept full-range, analog signals from virtually all OEM head units and amplifiers. Depending on the specific architecture of your OEM system, you will need to choose appropriate connection points that maintain OEM functionality and provide appropriate input to the CL441dsp. It is recommended that you obtain a service manual for the vehicle you are working on in order to locate and identify the correct OEM wires. OEM signal and speaker wires are often twisted in pairs for each channel, making them easy to identify in a harness. You can also observe the color codes of the wires connected to the OEM speakers and trace those back to the OEM head unit or amplifier harness.

IMPORTANT!

The OEM audio signals connected to the OEM inputs of the CL441dsp must be full-range (20 Hz - 20 kHz bandwidth) or very close to it. Feeding crossed-over signals into the CL441dsp will result in noisy output or complete failure to calibrate. This error condition is indicated via flashing red lights after the calibration has been attempted.

Signals that are crossed over must be summed to full range using appropriate summing devices prior to being connected to the CL441dsp. Please contact your authorized dealer for assistance if this situation exists in your vehicle. Never attempt to sum signals by connecting different channels together directly!

If only two-channels of full-range audio are available from the OEM system, the CL441dsp can be used with only two channels connected (and will only output two channels of audio).

AUX INPUT CONNECTIONS

One of this product's best features is the ability to connect additional sources of your choice to your audio system. To connect an auxiliary source, you will need standard RCA-type audio interconnect cables. Depending on the source unit, you may need additional cable adaptors. If you wish to connect multiple audio sources to these jacks, you will need an additional source selector switch between the source units and the AUX Inputs of the CL441dsp.

If you will be powering the AUX source from the vehicle, it is a good practice to make the AUX source's power and ground connections at the same point as the CL441dsp power and ground connections. This minimizes the possibility of ground-loops and noise in the system. If your AUX source unit gives you the option of a fixed line level output or a variable output (controlled by its volume control), it is recommended that you use the fixed level output.

A pair of level trim potentiometers on the top of the CL441dsp chassis will permit you to level-match the AUX source to the OEM level. This should be done after calibrating the OEM Inputs. See the "Calibration" section on Pages 9 and 10.

Please note that the CL441dsp will not equalize the AUX source input in any way. The AUX source audio is passed, undisturbed, to the CL441dsp's outputs.

INPUT AND CONTROL CONNECTION DIAGRAM

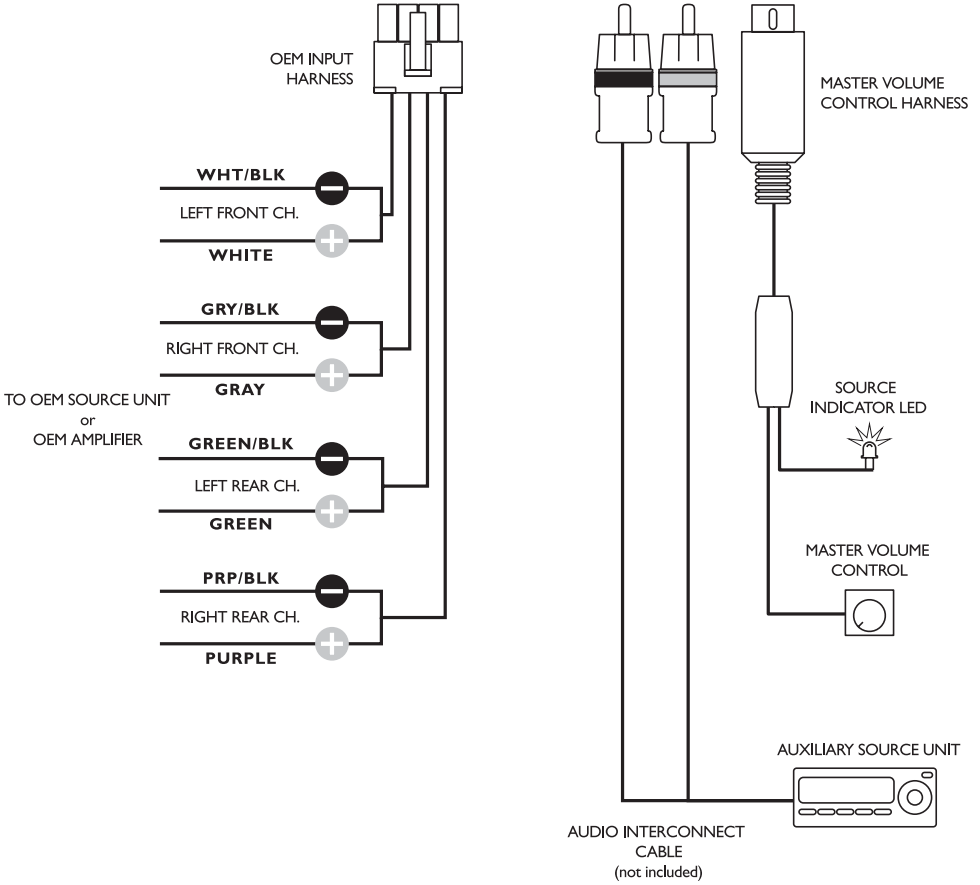
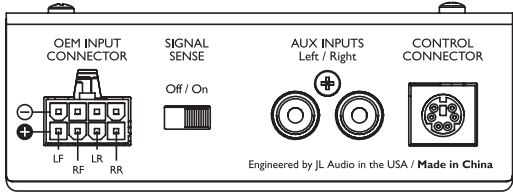

MASTER VOLUME CONTROL CONNECTIONS AND MOUNTING

The CL441dsp Master Volume Control serves two main functions:

- 1) To control the system volume
- 2) To switch between the OEM inputs and the AUX inputs (by pushing in on the knob).
If no AUX source is connected, the knob will mute / unmute the system when pressed.

For these reasons, you will want to locate the knob, within easy reach of the driver, on the center console or dashboard of the vehicle.

To mount the knob, first verify that sufficient clearance exists behind the mounting surface for the control assembly's small enclosure. Then, drill a 3/8-inch (9mm) diameter hole in the mounting surface. Remove the nut and washer from the threaded collar and insert the control assembly from behind the mounting surface. Place the washer over the shaft and secure with the nut. Finally, place one of the two supplied knobs over the shaft, orienting the knob marker appropriately relative to the rotation range of the control.

A small multi-color LED is also included to indicate which input mode is selected:

- Green = OEM Input Mode
- Red = AUX Input Mode

The LED can be mounted at the owner's discretion in the front of the vehicle, using the supplied mounting grommet. To mount the LED, first ensure that sufficient clearance exists for the LED body and leads behind the mounting surface. Then, drill a 8mm diameter hole in the mounting surface. Insert the LED from behind the mounting surface (without attaching the mounting grommet). Snap the mounting grommet over the LED body and insert it into the hole you have drilled until flush.

Once the LED and Master Volume Control are mounted, connect the Master Volume Control harness to the "CONTROL CONNECTOR" port on the CL441dsp main processor. If the cable length is insufficient, use the supplied extension cable.

Using the OEM head unit's volume control instead of the CL441dsp Master Volume Control:

If desired, the OEM (factory) volume control can be used to control the master system volume as long as you accept the following compromises:

- a) The factory volume control will not control the AUX source volume. Only the CL441dsp's Master Volume Control can control the AUX level.
- b) There may be a noticeable increase in system noise (hiss) at lower volume levels, compared to using the CL441dsp's Master Volume Control.
- c) There may be significant changes in frequency response imposed by the OEM system's volume-dependent equalization. These may be objectionable or acceptable, depending on the car and the desired performance of the system. In most cases, OEM systems boost bass and treble at lower volume settings (can be acceptable) and often cut bass at higher volume settings (more objectionable).

If no AUX source is being used and the sonic compromises of using the OEM control are acceptable, simply set the CL441dsp Master Volume Control at full output (fully clockwise) and hide it in the installation.

SIGNAL SENSE MODES

The CL441dsp is designed to act as a turn-on and turn-off controller for the aftermarket components in your system. There are two modes of turn-on operation which can be selected via the "SIGNAL SENSE" slide-switch located next to the OEM Input Connector:

SIGNAL SENSE: ON

In most cases, you will want to use this mode which requires that the "IGN" terminal of the CL441dsp be connected to a wire with accessory/ignition-switched +12V. In this mode, the CL441dsp will only wake up and turn on the rest of the system when it senses +12 V at its "IGN" terminal and also senses an input signal from the OEM audio source. If the vehicle is turned on with the OEM source unit turned off, the CL441dsp will remain in standby mode until the OEM source is turned on and playing. The CL441dsp will go into Standby Mode (off) one minute after it senses a loss of input signal or as soon as the ignition is turned off (whichever comes first).

Note: You must have the OEM source unit playing in order to listen to the AUX source when the "Signal Sense" mode is "on".

SIGNAL SENSE: OFF

With the "Signal Sense" switch in the "off" position, the CL441dsp will wake up and provide +12V at its "REM.OUT" terminal whenever it senses +12V at its "IGN" terminal (regardless of whether the OEM source is on or not). This position can be useful if another device is being used to toggle the CL441dsp on/off, or if the OEM system has a conventional +12 V turn-on output (very rare). The "off" position can also be used with a manual switch on the wire feeding the "IGN" terminal for those who desire manual control of on/off functions. This switch should be connected to an ignition-switched +12V to prevent accidental battery drainage. If you decide to ignore the foregoing and use a manual switch fed by constant +12V, be aware that forgetting to shut the system off will result in battery drainage.

CALIBRATION

Once you have made all your system connections, follow these steps precisely:

- 1) Turn the CL441dsp's Master Volume Control all the way DOWN (fully counterclockwise).
- 2) Reconnect the vehicle's battery ground.
- 3) Turn the OEM head unit on and make sure it is playing something (radio or CD, doesn't matter right now). Set all of the OEM head unit tone controls at "0" (flat), and the balance and fader controls at their center positions. Turn off any factory DSP features, such as "Concert Hall" or "Stadium" or music genre-specific equalization settings.
- 4) Verify that the CL441dsp and all of the aftermarket equipment have turned on.
- 5) Slightly raise the CL441dsp Master Volume Control to verify that audio is passing through to the aftermarket system. Once verified, turn the Master Volume Control all the way down (fully counterclockwise).
- 6) Insert the included CleanSweep™ Calibration CD into the OEM CD player, play Track "01" and set the OEM head unit volume control between 1/2 and 3/4 of full volume.
- 7) Using a small pointed tool or a paper clip, press the "CALIBRATE" button on the top of the CL441dsp.
- 8) Wait approximately twenty seconds... lights will flash in various colors to keep you entertained and to indicate that calibration is taking place. After twenty seconds, the lights will stabilize and indicate whether calibration has been successful on each channel.
- 9) If you see four steady green lights (or two if you only connected two channels of input), your calibration was successful. If you do not see steady green lights, refer to the "Channel Status Codes" section on Page 11 for troubleshooting.

- 10) If you see steady green lights, you can now proceed to set your amplifier input sensitivities (handy test tones are included for this purpose on the CleanSweep™ Calibration CD). Then, balance your amplifier channels to taste.
- 11) If an AUX source is connected, use the “AUX INPUT Level Trim” controls on the top of the CL441dsp to adjust the level of the AUX source so that it matches the level of the OEM source and so that both channels of the AUX source are properly balanced. Use similar music or test tones playing through each source unit for best results. If the “CLIP” indicator lights flash or light continuously, reduce the level until they no longer light up.
- 12) That’s it! You’re now ready to enjoy great sound.

EQ DEFEAT MODE

If you would like to verify the effect of the CL441dsp’s OEM equalization function, you can press the “EQ DEFEAT” button on the top of the unit when it is in OEM Input mode.

In “EQ DEFEAT” mode, the channel status LED’s will flash green and the CL441dsp’s response correction is bypassed, allowing you to hear the raw response of the OEM audio source. The Defeat Mode will stay engaged for up to five minutes or until you press the “EQ DEFEAT” button again.

USING YOUR NEW AUDIO SYSTEM

The “Audiophile Method”:

For best audio performance you will want to use the CL441dsp’s Master Volume Control as your main system volume knob for all sources. This will maintain linear frequency response at all volume levels and the best possible signal-to-noise performance.

Once the CL441dsp is installed and calibrated, make a note of the specific volume position you used on the OEM source unit to calibrate the CL441dsp. From now on, you will operate your audio system with the OEM control set at this level. Most source units provide a numerical or graphic representation of the volume position on their display. If yours does not, you will simply need to estimate the position using minimum or maximum as a reference point and remembering the degree of rotation from that point.

Leaving the OEM volume control at the calibration level, you will use the Master Volume Control for volume adjustment, but you may continue to use the OEM source unit’s tone controls, fader and balance controls, if desired.

To select the AUX input, simply press down on the Master Volume Control Knob. The Source Indicator LED lights Green for the OEM source and Red for the AUX source. If no AUX source unit is connected, the system will mute when AUX is selected (so, if you’re ever sitting there wondering what happened to your sound, chances are you need to press the knob to re-engage the OEM Input.)

Important Notice for All Users!

Keep in mind that any audible OEM functions that depend on the OEM audio system will only be audible when the OEM Input is engaged. Driver assistance systems (like OnStar®), navigation systems, and door chimes on some vehicles are examples of such functions. If these functions are important to your current driving situation, do not use the AUX input.

The “Creature Comfort Method”:

Being audio purists, we strongly recommend that you use the CL441dsp’s Master Volume Control for all volume adjustments. If placed on the center console, it can be even more convenient to use than the OEM control.

If you are unmoved by our recommendation and still prefer to use the OEM head unit’s volume knob or the steering wheel volume controls, simply set the CL441dsp’s Master Volume Control at a comfortable level and use the OEM volume control(s) for routine adjustment. You may experience some changes in the frequency response at low and high volumes. These shifts may or may not be acceptable, depending on your vehicle and your listening tastes. You may also experience an increase in system hiss at lower volume levels.

To switch to AUX Input mode and to control the level of the AUX Source (if one is connected), you will need to use the CL441dsp’s Master Volume Knob. The OEM volume controls will have no effect on the AUX Source level.

CHANNEL STATUS CODES:

GREEN (steady):

OEM Input Engaged / EQ Successful & Active

This indicates that the CL441dsp has effectively corrected the OEM response and is in OEM Input Mode.

GREEN (flashing):

OEM Input Engaged / EQ Defeated

This indicates that the OEM Input Mode is engaged and the CL441dsp’s equalizer has been defeated by pressing the “EQ DEFEAT” button. This mode allows you to compare the raw OEM response to the corrected response and will remain engaged for a maximum of five minutes (in case you forget you pressed the “EQ DEFEAT” button). To exit this mode manually, press the “EQ DEFEAT” button again.

AMBER (steady):

AUX Input Engaged / EQ Defeated

This indicates that the AUX input signal is being passed to the CL441dsp’s outputs without any equalization.

RED/GREEN (alternating):

EQ Active, only partial correction was achieved.

This indicates that the CL441dsp corrected the frequency response to the best of its abilities, but failed to achieve a flat response. The output may be usable, but merits investigation with a Real Time Analyzer.

RED (steady):

Calibration Failed due to insufficient input signal, previous settings have been restored for those channels exhibiting this code.

This indicates that there was insufficient or non-existent signal present on the channels exhibiting this code. If you only connected two channels of input, the other two channels will show this code. If this code appears on channels you attempted to connect, you will need to verify that signal was present at the CL441dsp’s OEM Inputs during calibration and that this signal was analog audio.

RED (flashing):

Calibration Failed (input signal not full-range), previous settings have been restored for those channels exhibiting this code.

This indicates that the signals connected to the channels exhibiting this code were not full-range and were not able to be corrected. You will need to analyze the input signals with a Real Time Analyzer and see if these can be summed with other signals (using a summing device) before connecting them to the CL441dsp’s inputs. You may also choose to use only two channels if this error code only exists on one channel pair.

PARTS LIST

- (1) CleanSweep™ CL441dsp Processor
- (1) Master Volume Control Harness with LED
- (2) Extra nuts for Master Volume Control
- (2) Extra washers for Master Volume Control
- (1) Mounting grommet for LED
- (1) Master Volume Control Extension Cable (18 ft.)
- (1) Black Knob for Master Volume Control
- (1) Silver Metallic Knob for Master Volume Control
- (1) Power connection harness with plug
- (1) OEM input connection harness with plug
- (1) CleanSweep™ Calibration CD

SPECIFICATIONS

CleanSweep™ CL441dsp
OEM Interface / Processor

ELECTRICAL SPECIFICATIONS:

Power Supply Type: PWM Switching Supply - Regulated
Operating Voltage: 9 - 16V DC
Standby Mode Current Draw: < 2 mA
Operating Current Draw: 0.5 A at 13.8 V
Recommended Fuse Value: 1 A (Fast Blow)
Recommended Fuse Type: AGC

OEM INPUT SECTION:

No. of Input Channels: Four
Input Type: Differential-balanced with multi-pin jack / plug
Input Range: 100mV - 30V RMS
Input Level Setting: Fully Automatic

AUX INPUT SECTION:

No. of Input Channels: Two (feed all four output channels)
Input Type: Differential-balanced with dual RCA jacks
Input Range: 250mV - 4V RMS
Input Level Setting: Manual with individual level trim controls and LED clipping indicators

DIGITAL SPECIFICATIONS:

Processor: 32 bit SHARC® floating point DSP
Audio Resolution: 24 bit
No. of EQ Bands: 120 (30 x 4 channels)
EQ Resolution: 1/3 octave from 25 Hz - 20 kHz

OUTPUT SECTION:

No. of Output Channels: Four
Output Type: Unbalanced, via RCA Jacks
Maximum Output Voltage: 8V RMS (per output)
Output Impedance: 470 ohms
Signal to Noise Ratio: >102 dB (A-Weighted, referenced to rated output)
THD + Noise: < 0.01% at rated output (20Hz - 20 kHz)

DIMENSIONS: (LxWxH):

9.72 in. x 4.37 in. x 1.54 in. (247 mm x 111 mm x 39 mm)

Due to ongoing product development, all specifications are subject to change without notice.

U.S. and International Patents Pending

INSTALLATION NOTES

INSTALLATION NOTES

LIMITED WARRANTY - ELECTRONICS (USA)

JL AUDIO warrants this product to be free of defects in materials and workmanship for a period of ninety (90) days from the original date of purchase. The warranty term is extended to two (2) years if installation is performed or approved by an authorized JL AUDIO dealer (proof of installation or approval required on purchase receipt).

This warranty is not transferrable and applies only to the original purchaser from an authorized JL AUDIO dealer. Should service be necessary under this warranty for any reason due to manufacturing defect or malfunction, JL AUDIO will (at its discretion), repair or replace the defective product with new or remanufactured product at no charge. Damage caused by the following is not covered under warranty: accident, misuse, abuse, product modification or neglect, failure to follow installation instructions, unauthorized repair attempts, misrepresentations by the seller. This warranty does not cover incidental or consequential damages and does not cover the cost of removing or reinstalling the unit(s). Cosmetic damage due to accident or normal wear and tear is not covered under warranty.

Warranty is void if the product's serial number has been removed or defaced.

Any applicable implied warranties are limited in duration to the period of the express warranty as provided herein beginning with the date of the original purchase at retail, and no warranties, whether express or implied, shall apply to this product thereafter. Some states do not allow limitations on implied warranties, therefore these exclusions may not apply to you. This warranty gives you specific legal rights, and you may also have other rights which vary from state to state.

If you need service on your JL AUDIO product:

All warranty returns should be sent to JL AUDIO's Electronics Service Facility freight-prepaid through an authorized JL AUDIO dealer and must be accompanied by proof of purchase (a copy of the original sales receipt). Direct returns from consumers or non-authorized dealers will be refused unless specifically authorized by JL AUDIO with a valid return authorization number.

Warranty expiration on products returned without proof of purchase will be determined from the manufacturing date code. Coverage may be invalidated as this date is previous to purchase date. Non-defective items received will be returned freight-collect. Customer is responsible for shipping charges and insurance in sending the product to JL AUDIO. Freight damage on returns is not covered under warranty.

For Service Information in the U.S.A. please call:

JL Audio customer service: (954) 443-1100

during normal business hours (9:00 AM – 5:30 PM Eastern Time)

JL Audio, Inc

10369 North Commerce Pkwy.

Miramar, FL 33025

(do not send product for repair to this address)

International Warranties:

Products purchased outside the United States of America are covered only by that country's distributor and not by JL Audio, Inc.