

# KitchenAid® 30" Freestanding and Slide-In Electric Range

## PRODUCT MODEL NUMBERS

KERA807P	KESA907P
KERK807P	KESI901P
KERV808P	KESV908P

**Electrical:** When a 4-wire or 3-wire, single phase 120/240-volt, 60 Hz, AC-only electrical supply is available, a 50 amp maximum circuit protection is required (or, if specified on the model/serial rating plate, when a 4-wire or 3-wire single phase 120/208-volt 60 Hz, AC-only electrical supply is available, a 40 amp maximum circuit protection is required), fused on both sides of the line. The model/serial number rating plate is located on the oven frame behind the storage drawer panel. A time-delay fuse or circuit breaker is recommended.

## OVERALL DIMENSIONS

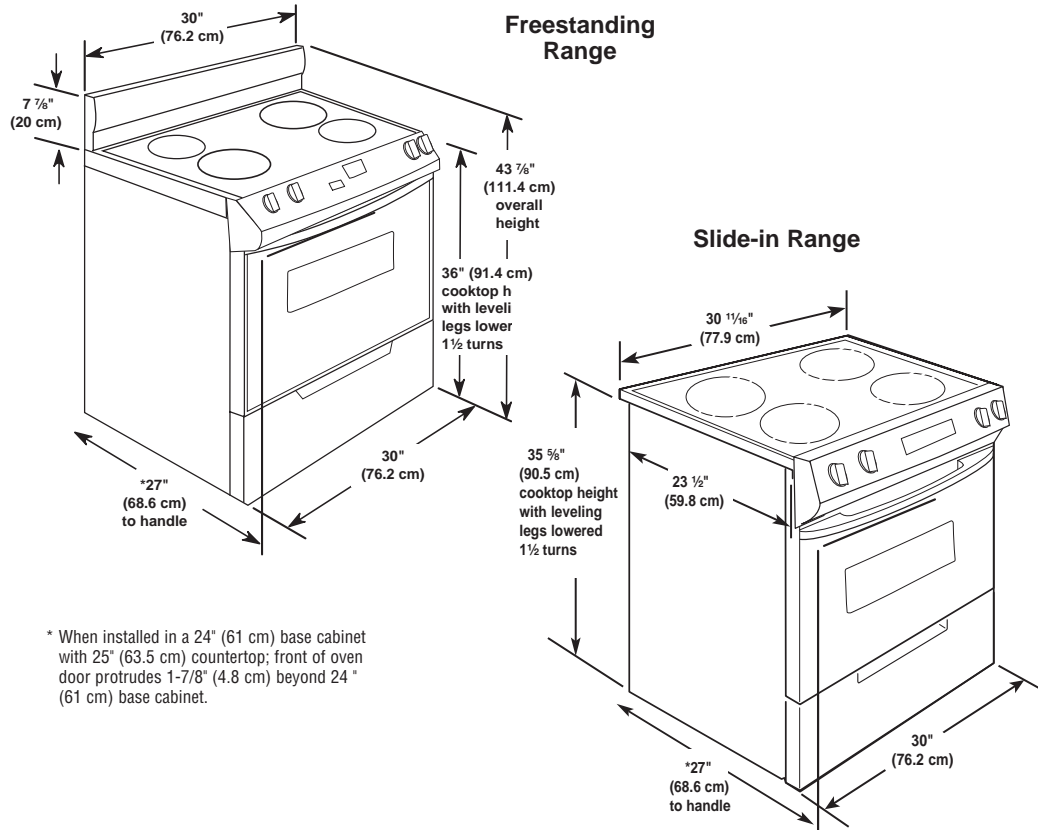

## SLIDE-IN RANGE COUNTERTOP PREPARATION

The cooktop sides of the slide-in range fit over the cutout edge of your countertop.

If you have a square finish (flat) countertop and the opening width is 30" (76.2 cm), no countertop preparation is required.

Formed front-edged countertops: Must have molded edge shaved flat 3/8" (1.0 cm) from each front corner of opening.

Tile countertops may need trim cut back 3/8" (1.0 cm) from each front corner and/or rounded edge flattened.

If countertop opening width is greater than 30", adjust the 3/8" (1.0 cm) dimension.

Countertop must be level. Place level on countertop, first side to side; then front to back. If countertop is not level, range will not be level. Oven must be level for satisfactory baking performance.

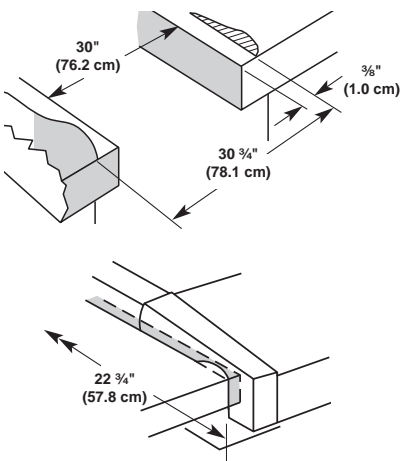

## CABINET OPENING DIMENSIONS

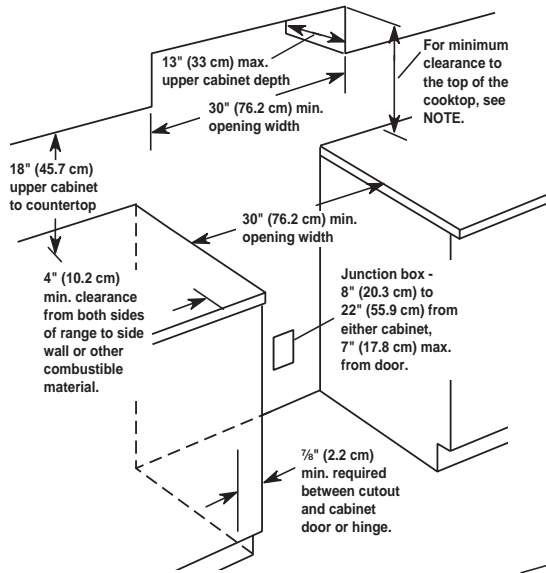

**NOTE:** 24" (61 cm) min. when bottom of wood or metal cabinet is protected by not less than 1/4" (0.64 cm) flame retardant millboard covered with not less than No. 28 MSG sheet steel, 0.015" (0.4 mm) stainless steel, 0.024" (0.6 mm) aluminum or 0.020" (0.5 mm) copper.

30" (76.2 cm) min. clearance between the top of the cooking platform and the bottom of an unprotected wood or metal cabinet.

Cabinet opening dimensions shown are for 25" (64 cm) countertop depth, 24" (61 cm) base cabinet depth and 36" (91.4 cm) countertop height.

