

Frigidaire

Factory Parts Catalog

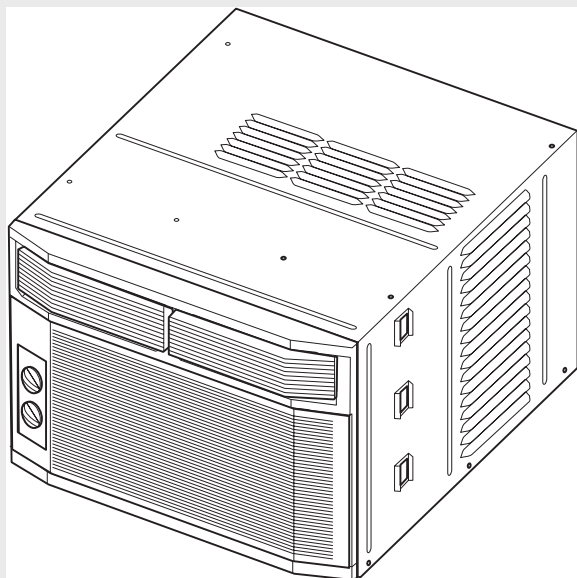

Product No.	FAC104P1A1	FAC104P1A2	FAC104P1A3	FAC104P1A4	FAC104P1A5	FAC104P1A6
Series	ROOM AIR	ROOM AIR	ROOM AIR	ROOM AIR	ROOM AIR	ROOM AIR
Color	white	white	white	white	white	white
Volts	115	115	115	115	115	115
BTU-Cooling	10,000BTU	10,000BTU	10,000BTU	10,000BTU	10,000BTU	10,000BTU
Owner's Guide	220201d011	220201d011	220201d011	220201d011	220201d011	220201d011
Installation Instructions	COMINSTALLEN	COMINSTALLEN	COMINSTALLEN	COMINSTALLEN	COMINSTALLEN	COMINSTALLEN
Market	North America	North America	North America	North America	North America	North America

 **Electrolux**

Electrolux Major Appliances
North & Latin America
P.O. BOX 212378
AUGUSTA, GA 30917

Publication No.
5995436895
05/05/17
(EN/SERVICE/WC)
099

**ROOM AIR
CONDITIONER**

**Model No.
FAC104P1**

Copyright © 2005 Electrolux Home Products, Inc.
All rights reserved.

CABINET, FRONT, CONTROLS

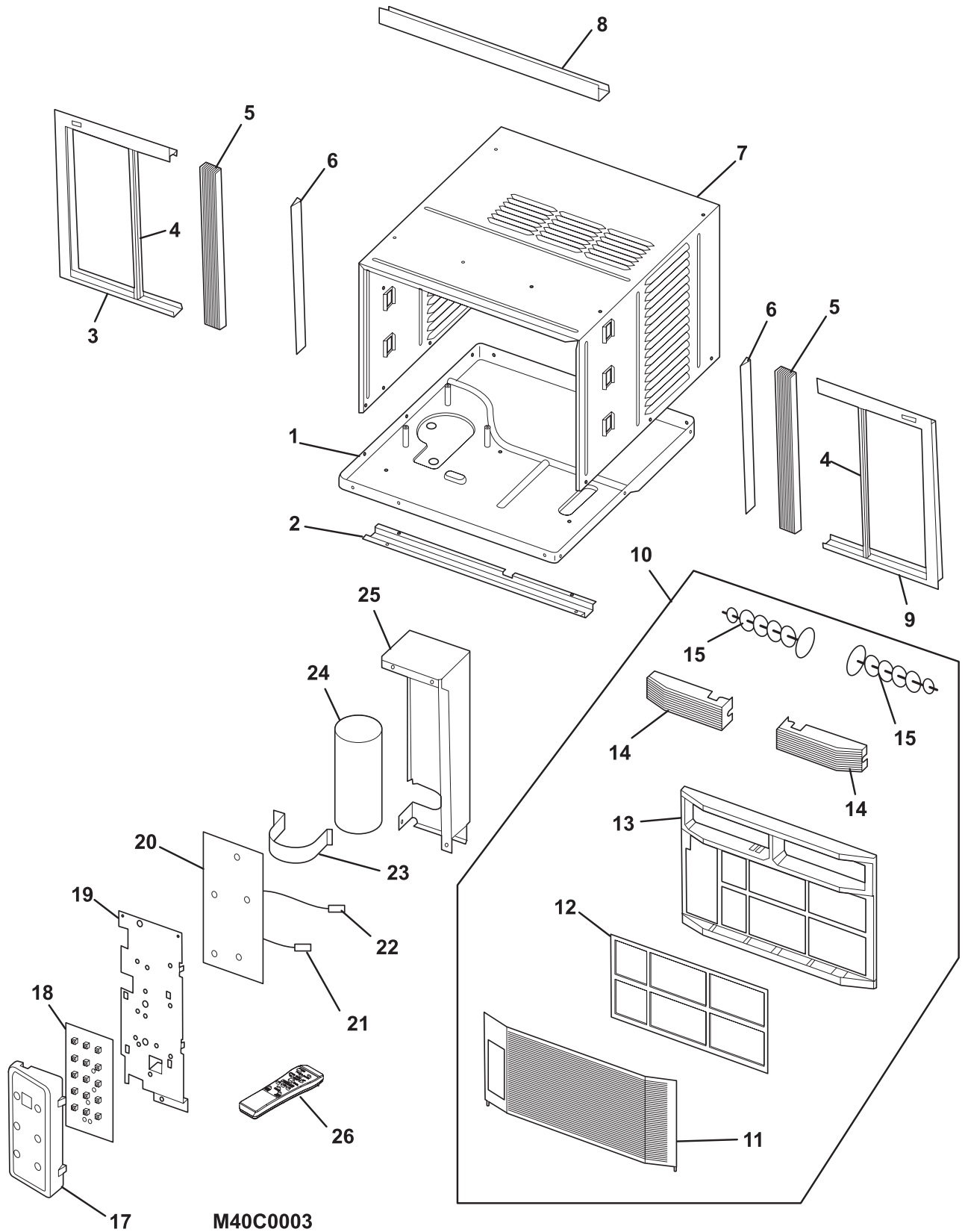

CABINET, FRONT, CONTROLS

Model Index: A FAC104P1A (FAC104P1A1)
 B FAC104P1A (FAC104P1A2)
 C FAC104P1A (FAC104P1A3)
 D FAC104P1A (FAC104P1A4)
 E FAC104P1A (FAC104P1A5)
 F FAC104P1A (FAC104P1A6)

POS. NO	PART NO.		DESCRIPTION
1	5304436522	A B - - - F	Base, unit chassis
1	5304436521	- - C D E -	Base, unit chassis
2	5304436523	A B C D E F	Rail, shutter track, bottom
3	5304436544	A B C D E F	Frame, shutter panel, LH
4	5304436545	A B C D E F	Retainer, shutter lock
5	5304436546	A B C D E F	Shutter, accordion panel
6	5304436547	A B C D E F	Retainer, shutter mount, cabinet sides
7	5304446442	A B C D E F	CABINET, WRAPPER/SLEEVE
8	5304436549	A B C D E F	Rail, shutter track, top
9	5304436550	A B C D E F	Frame, shutter panel, RH
10	5304436599	A B C D E F	Front Assembly, complete panel, includes
11	5304436551	A B C D E F	Panel, front grille, tilt-out
12	5304436552	A B C D E F	Filter, air, plastic frame
13	5304436553	A B C D E F	Frame, front assembly
14	5304436554	A B C D E F	Louver, horizontal
15	5304446443	A B C D E F	LOUVRES, VERTICAL
17	5304436536	A B C D E F	Enclosure, control, pcb display
17	5304436537	A B C D E F	Control Panel, display, electronic
18 #	5304436534	A B C D E F	PC Board, display/input
19	5304446441	A B C D E F	PANEL, CTRL MTG BOARD
20 #	5304436531	A B C D E F	PC Board, control/power
21 #	5304436543	A B C D E F	Sensor, ambient temp
22 #	5304436542	A B C D E F	Sensor, evap temp, defrost
23	5304436530	A B C D E F	Strap, capacitor mtg.
24 #	5304436526	A B - - - F	Capacitor
24 #	5304436527	- - C D E -	Capacitor
25	5304436524	A B C D E F	Control Box
26 #	5304436595	A B C D E F	Remote Control, transmitter

COOLING & AIR FLOW SYSTEMS

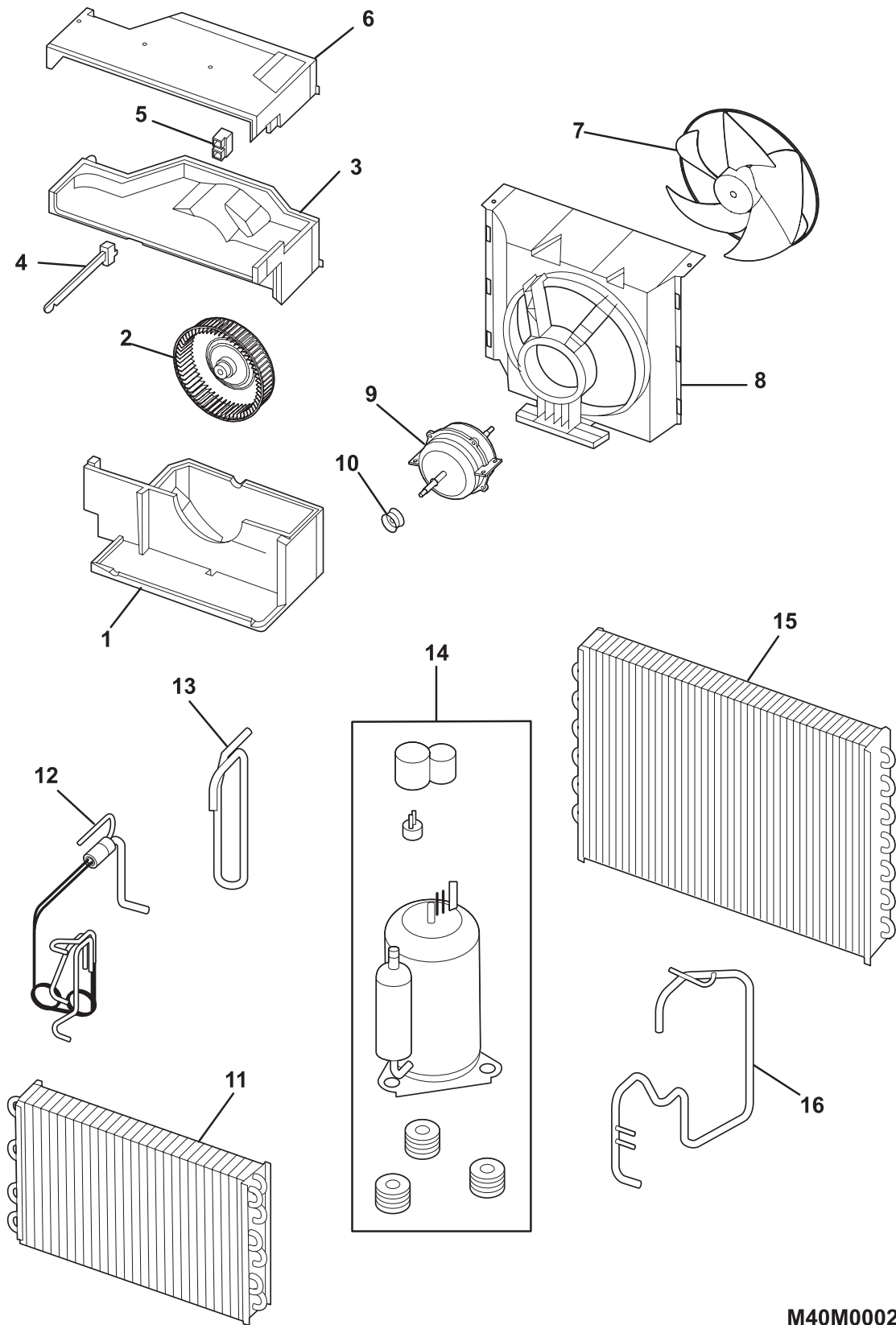

M40M002

COOLING & AIR FLOW SYSTEMS

Model Index: A FAC104P1A (FAC104P1A1)
 B FAC104P1A (FAC104P1A2)
 C FAC104P1A (FAC104P1A3)
 D FAC104P1A (FAC104P1A4)
 E FAC104P1A (FAC104P1A5)
 F FAC104P1A (FAC104P1A6)

POS. NO	PART NO.		DESCRIPTION
1	5304436556	A B C D E F	Scroll, blower housing, bottom, w/drain tray
2 #	5304436557	A B C D E F	Blower Wheel, centrifugal fan
3	5304436559	A B C D E F	Scroll, blower housing, top
4	5304436558	A B C D E F	Door, fresh air vent, with lever
5	5304436564	A B C D E F	Guide, vent door/lever
6	5304436565	A B C D E F	Cover, blower scroll, top
7 #	5304436563	A B C D E F	Fan Blade, propeller, axial flow
8 #	5304436562	A B C D E F	Shroud, fan housing
9 #	5304441406	A - - D - -	Motor, fan
9	5304446455	- B - - E -	Motor-fan
9 #	5304441405	- - C - - F	Motor, fan
10	5304436560	A B C D E F	Seal, fan motor, rubber ring, water proof
11 #	5304436567	A B - - - F	Evaporator
11	5304446451	- - C D E -	Evaporator
12	5304446448	A B - - - F	Tube-capillary
12	5304446454	- - C D E -	Tube-capillary
13	5304446447	A B - - - F	Tube-discharge
13	5304446453	- - C D E -	Tube-discharge
14 #	5304446446	A B - - - F	COMPRESSOR ASSY, W/OVERLOAD
14 #	5304437083	- - C D E -	Compressor Assy
15 #	5304436571	A B - - - F	Condenser
15	5304446452	- - C D E -	Condenser
16	5304446445	A B - - - F	TUBE-SUCTION
16 #	5304436570	- - C D E -	Suction Tube
*	5304446449	A B C D E F	CORD, ELECTRIC SERVICE

