

29R • 21" ADA Solid Door Refrigerator • ADA Series

FEATURES & BENEFITS



BLACK SOLID



BLACK SOLID (LOCK)



WHITE SOLID



WHITE SOLID (LOCK)

PERFORMANCE	<ul style="list-style-type: none"> • Volume of 3.3 cu ft holds up to 35 bottles (12 oz) or 48 cans (12 oz) • Mechanical Dial Control is conveniently located on the grille • Temperature range: 34°F - 45°F • Mechanical passive cooling system
INTERIOR/EXTERIOR	<ul style="list-style-type: none"> • Three removable tempered glass shelves • Three fixed shelves in door • Door swing is field reversible for non-lock models • Door lock models are available, and must be ordered hinge specific
INTEGRATION	<ul style="list-style-type: none"> • Unit is designed to be built-in or can be freestanding • Non-lock models accepts a 1/4" custom insert panel • Available in the following finishes: Black or White

MODEL DETAILS

Model	Voltage/Hz	Door Swing	Finish	Shipping Weight	Dealer	UMRP	MAP*	Sug. List
U-29RB-00A	115 / 60	Field Reversible	Black Solid	89 lbs	\$X,XXX	\$X,XXX	\$1,049	\$1,099
U-29RB-13A	115 / 60	Right-Hand Hinge	Black Solid (Lock)	89 lbs	\$X,XXX	\$X,XXX	\$1,129	\$1,189
U-29RB-15A	115 / 60	Left-Hand Hinge	Black Solid (Lock)	89 lbs	\$X,XXX	\$X,XXX	\$1,129	\$1,189
U-29RW-00A	115 / 60	Field Reversible	White Solid	89 lbs	\$X,XXX	\$X,XXX	\$1,049	\$1,099
U-29RW-13A	115 / 60	Right-Hand Hinge	White Solid (Lock)	89 lbs	\$X,XXX	\$X,XXX	\$1,129	\$1,189
U-29RW-15A	115 / 60	Left-Hand Hinge	White Solid (Lock)	89 lbs	\$X,XXX	\$X,XXX	\$1,129	\$1,189

*MAP refers to U-Line Corporation's U.S. Minimum Advertised Price (MAP) Policy. Please contact your distributor and/or U-Line Regional Sales Manager to ensure you have received a copy of the MAP policy and are in compliance.

ADA Series • 21" ADA Solid Door Refrigerator • 29R

DIMENSIONS

Dimensions shown apply to all finishes, including Integrated (INT) models with 3/4" integrated panel/frame installed.

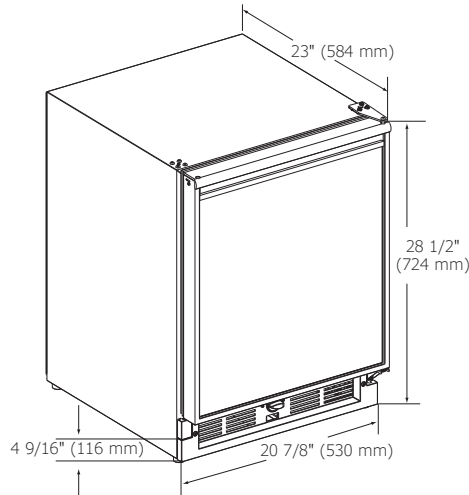

CABINET CUT-OUT

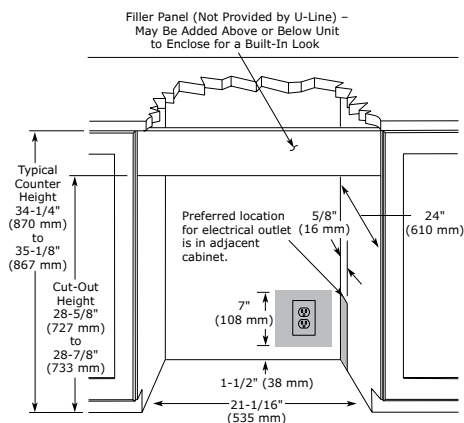

SPECIFICATIONS

Model	29R
Amps: Running	1.2
Capacity: Bottle (12 oz)	35
Capacity: Can (12 oz)	48
Capacity: Volume (cu ft)	3.3
Control Type	Mechanical Dial
Dimensions: Product Depth	23" / 584 mm
Dimensions: Product Height	28 1/2" / 724 mm
Dimensions: Product Width	20 7/8" / 530 mm
Energy Consumption: Avg. Per Year	230 kWh
ENERGY STAR / CEE RATING	ENERGY STAR / Tier 1
Product Weight: Max	80 lbs
Refrigerant Type	R600a
Sabbath (Star K Certified)	No
Temperature Range	34°F - 45°F

INSTALLATION NOTES

- Cutout includes the additional 1/4" width overall to ensure proper installation.
- No additional clearance around sides, top or rear of unit is needed for ventilation.
- Do not obstruct front grille air flow.

COOLING SYSTEM



ELECTRICAL REQUIREMENTS

This unit requires a grounded a polarized 115 VAC, 60 Hz, 15 A power supply (normal household current).

Please visit U-Line.com to view this model's User Guide. All specifications are subject to change without notice.



Residential & Commercial