

Frigidaire

Factory Parts Catalog

Product No.	FFC0723DW0
Series	134A
Color	white
Volts	115
Wiring Diagram	216787900
Owner's Guide	216960000
Market	North America
Energy Guide	216793915

 **Electrolux**

ELECTROLUX HOME PRODUCTS, INC.
P.O. Box 212378, Augusta, GA 30917

Publication No.
5995415295
04/08/18
(EN/SERVICE/MLR)
365

FREEZER CHEST

Model No.
FFC0723DW

Copyright © 2004 Electrolux Home Products, Inc.
All rights reserved.

DOOR

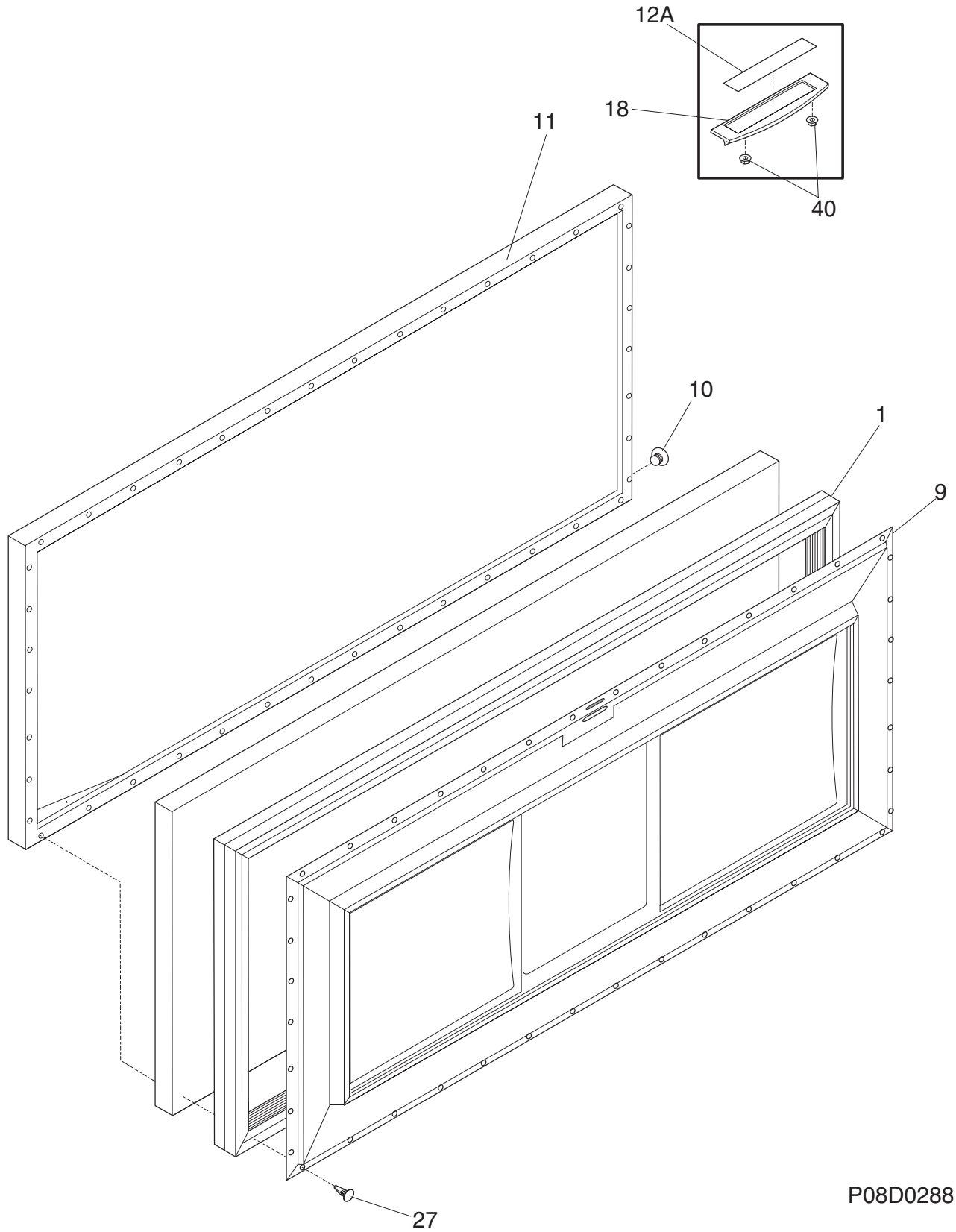

P08D0288

DOOR

POS. NO	PART NO.	DESCRIPTION
1	216480901	Gasket, door seal, white
9	216061602	Panel-inner lid, white
10	216923001	Plug button, 1/4", white
11	216113100	Panel-lid
*	5303161215	Screw, ph truss head, 8-18AB x 0.500
12A	216816801	Insert-nameplate
18	216446600	Handle
27	5303212828	Clip, panel mtg
40	216922700	Fastener, .330 dia stud, handle, (2)
*	5303917276	Insulation-door, fiberglass, (bulk)

CABINET

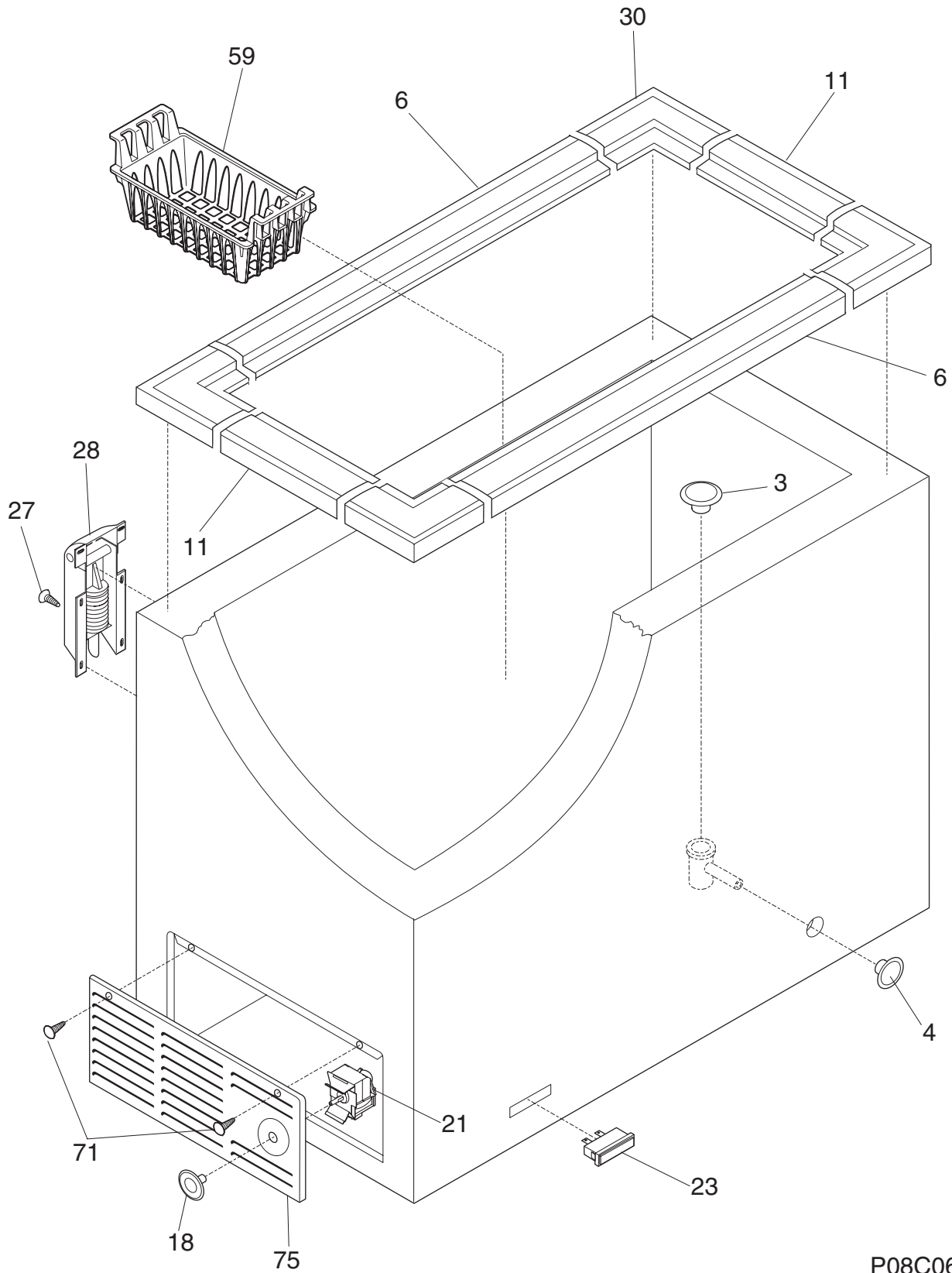

P08C0673

CABINET

POS. NO	PART NO.	DESCRIPTION
3	216502600	Plug, drain, interior
4	216073905	Plug-drain, exterior
6	216855702	Breaker, side
11	216855706	Breaker-ends, white
18	216707200	Knob, temp control
21 #	216787700	Control-temperature
23	06594648	Light-signal, amber
27	216337700	Screw, hex washer head, 10-24 x 0.500
28	216478800	Hinge Assy
30	216105500	Breaker-corners, white
59	216848200	Basket, (2)
71	131168200	Screw, pan head, 8-18B x 0.31
75	216782000	Panel-access, white
*	216793915	Energy Guide
*	5303305324	Paint, touch-up, white

SYSTEM

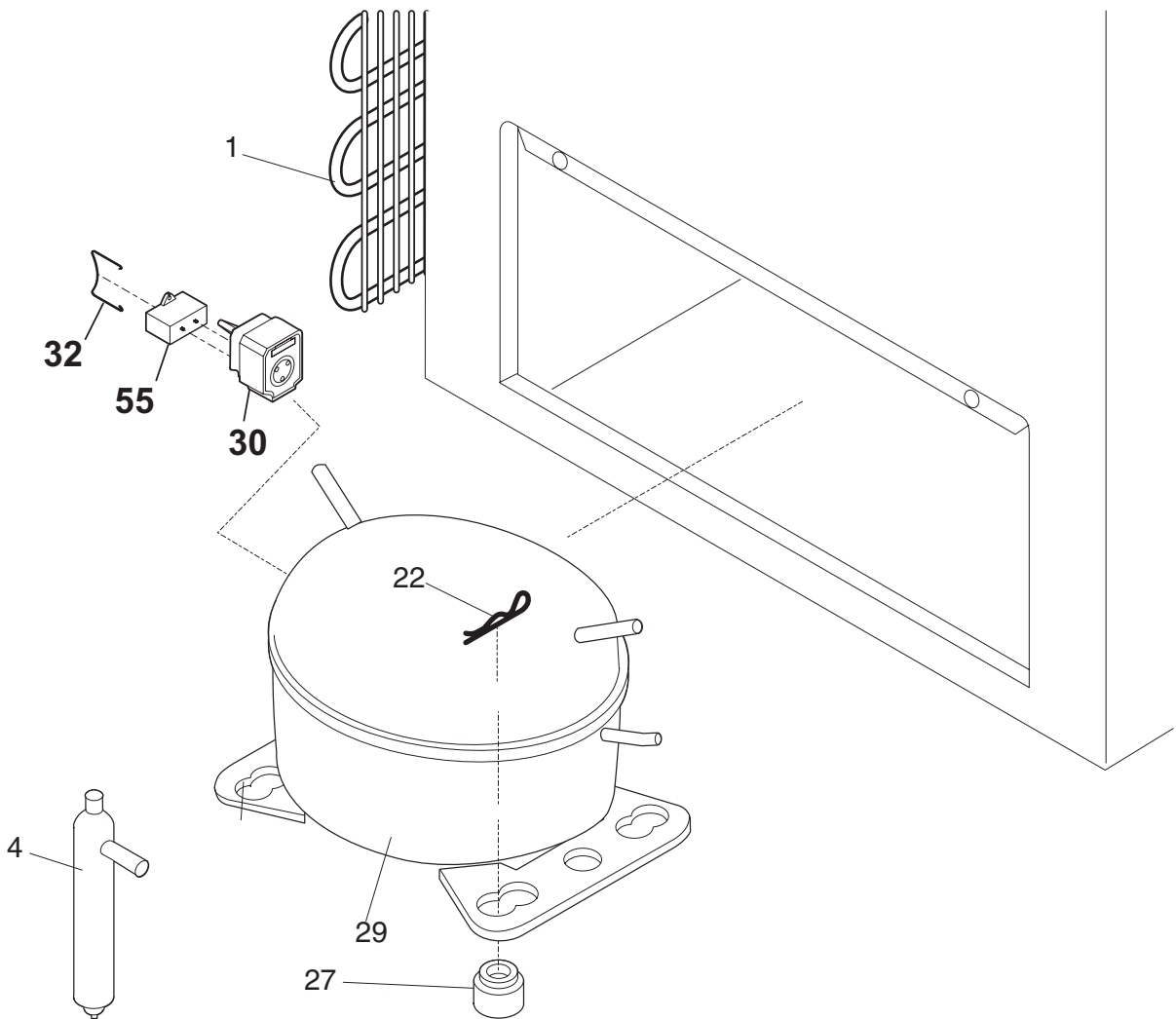
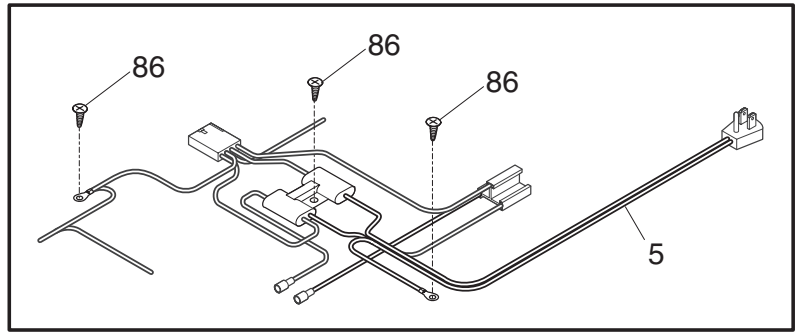
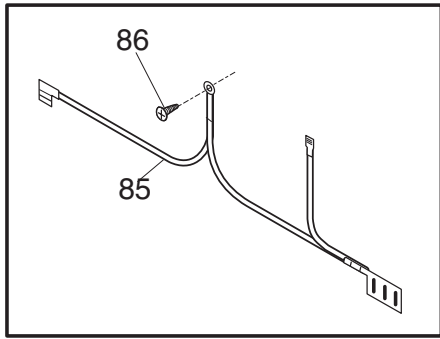

P08S0355

SYSTEM

POS. NO	PART NO.	DESCRIPTION
1 #	5300120780	Condenser
4	216634500	Drier-filter
5 #	216952300	Harness-main
*	216707800	Screw, PH, 8-32 x 1/2, wiring harness
22	216056400	Clip, compressor mtg, SPRING
27	5308002681	Grommet, compressor
29 #	216951200	Compressor, w/o electricals
30	216954200	Controller, compressor, 5 speed
32	216954300	Clip, controller
55 #	218909912	Capacitor-run, 220 VAC, 12 microfarad
85	216818300	Wire-ground
86	216707700	Screw, 8-18 X 1/2