



INSTALLATION INSTRUCTIONS FOR PART 99-8713

APPLICATIONS

Mercedes Benz SLK Class 2005-2010

99-8713

KIT FEATURES

- DIN radio provision with pocket
- ISO radio provision with pocket
- Double DIN radio provision
- Stacked ISO units provision



KIT COMPONENTS

A) Radio Housing B) ISO Brackets C) Trim Plate D) Double DIN Brackets E) Double DIN Trim Plate F) Pocket

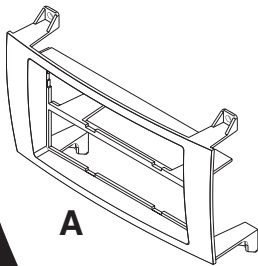

A

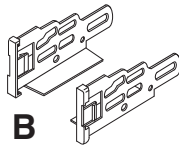

B

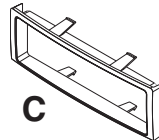

C

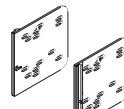

D

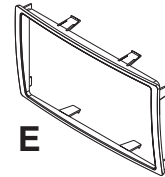

E

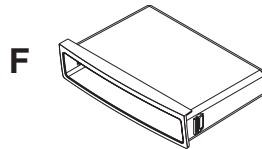

F

ANTENNA CONNECTIONS (Sold Separately)

Antenna adapter:

- 40-VW12 - Mercedes antenna adapter

TOOLS REQUIRED:

Socket Set • Torx Screwdriver • Small Flat Blade Screwdriver Or Panel Removal Tool

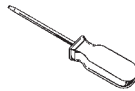
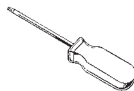
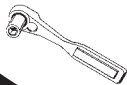

1-800-221-0932



www.metraonline.com

© COPYRIGHT 2004-2009 METRA ELECTRONICS CORPORATION

TABLE OF CONTENTS

Dash Disassembly

Mercedes Benz SLK Class 2005-2010 1-2

Kit Assembly

DIN Radio Provision with Pocket.. 3

ISO Radio Provision with Pocket.. 4

Double DIN Radio Provision 5

Stacked ISO Units Provision 6

Final Assembly 7

Note: Refer also to the instructions included with the aftermarket radio.

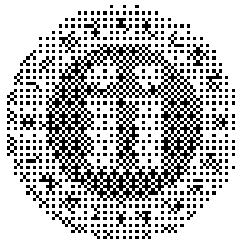

KNOWLEDGE IS POWER

Maximize your best interests and satisfaction while by applying to the most recognized and connected mobile electronics retailer in our industry. Log onto www.metradirectonline.com or call 800-899-8777 for more information and take steps toward a better radio now.

MERCEDES BENZ SLK CLASS 2005-2010

- 1 Disconnect the negative battery terminal to prevent an accidental short circuit.
- 2 Unclip and remove trim around shifter knob including shifter boot. (Figure A)
- 3 Unclip and remove entire panel surrounding shifter starting at the rear of the panel under the parking brake handle. (Figure B)
- 4 Unclip and remove the cigarette lighter housing trim panel. (Figure C)
- 5 Open the ashtray assembly and remove the (2) screw covers on the screws securing the assembly. (Figure D)
- 6 Remove the (2) screws securing the ashtray assembly then remove the whole unit including the cigarette lighter housing. (Figure E)

A

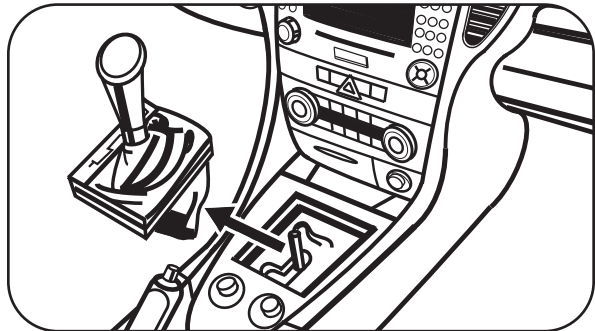

B

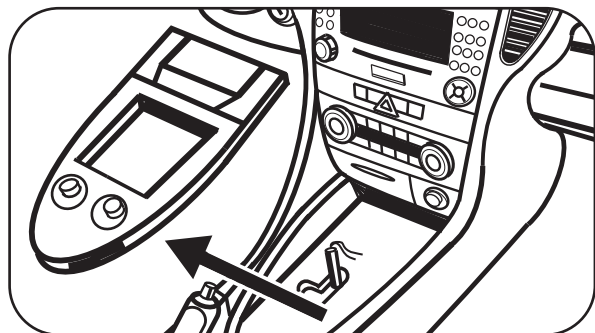

C

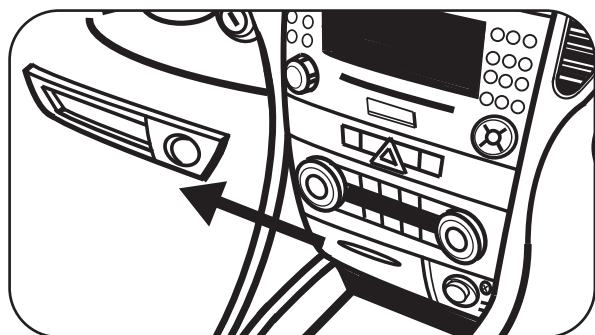

E



D



MERCEDES BENZ SLK CLASS 2005-2010

- 7 Unclip and remove the climate control unit. (Figure F)
- 8 Remove the (2) screws securing the hazard switch panel and remove the panel. (Figure G)
- 9 Open the beverage holder above the radio and remove the (2) screw covers. (Figure H)
- 10 Remove the (2) screws securing the beverage holder then remove the unit. (Figure I)
- 11 Remove the (4) screws securing the radio then remove the unit. (Figure J)

F

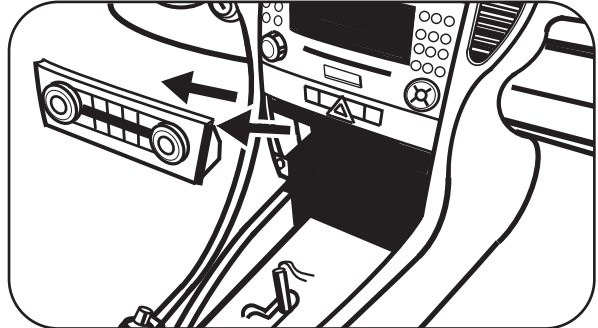

G

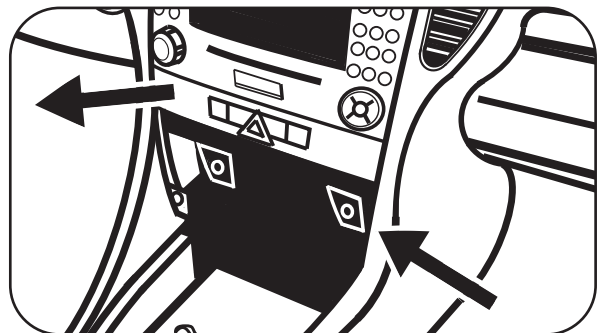

H

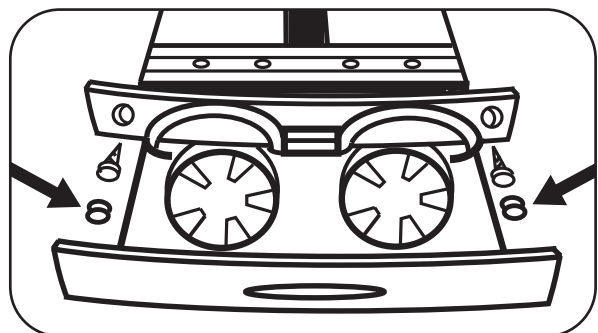

Continue to kit assembly.

J

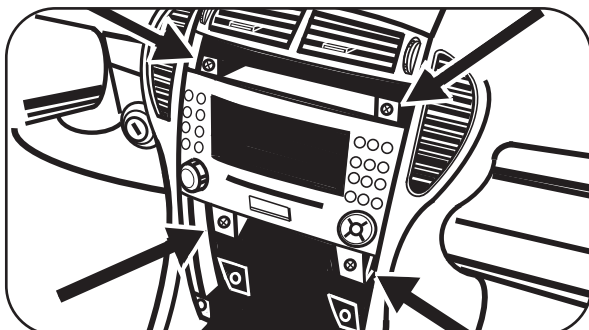

I

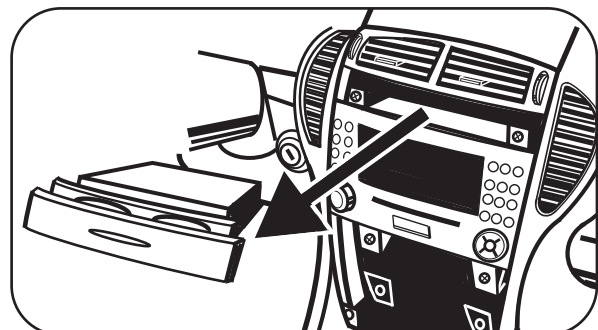

DIN RADIO PROVISION WITH POCKET

Note: Refer also to the instructions included with the aftermarket radio.

- 1 Slide the DIN cage into the Radio Housing and secure by bending the metal locking tabs outward. (Figure A)
- 2 Slide the aftermarket radio into the cage until it snaps into place. (Figure B)
- 3 Snap the pocket into the Radio Housing. (Figure C)

A

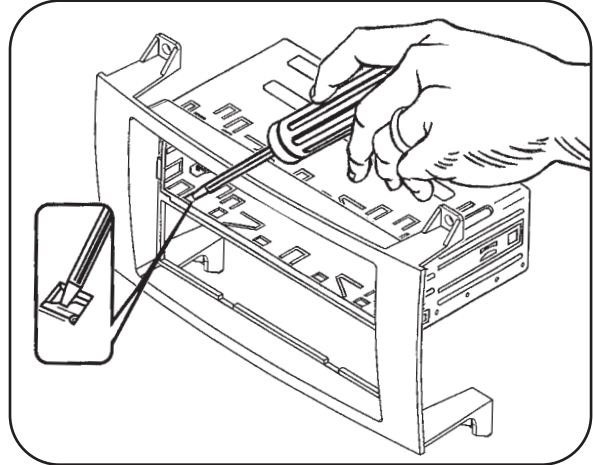

B

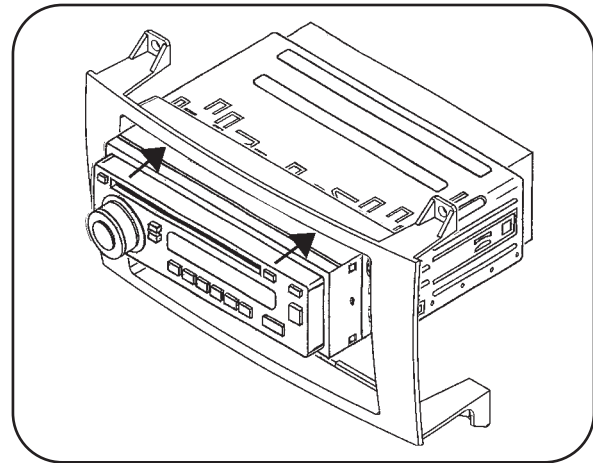

C

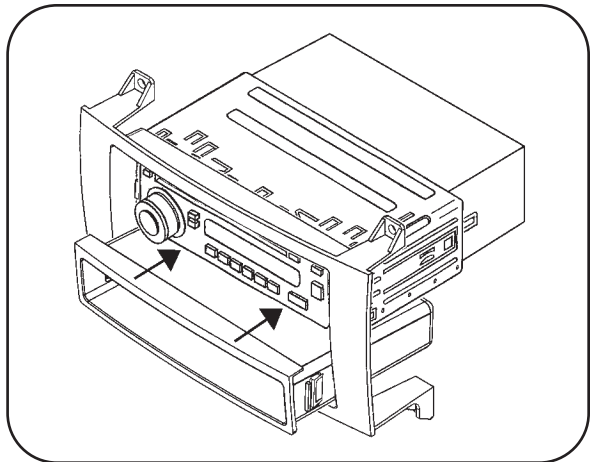

Continue to final assembly.

ISO RADIO PROVISION WITH POCKET

Note: Refer also to the instructions included with the aftermarket radio.

- 1** Mount the ISO Brackets to the radio with the screws supplied with the radio. (Figure A)
- 2** Slide the radio into the radio housing until the side clips snap into place. (Figure B)
- 3** Snap the Trim plate over the front of the Radio Housing. (Figure B)
- 4** Snap the Pocket into the Radio Housing. (Figure C)

Continue to final assembly.

A

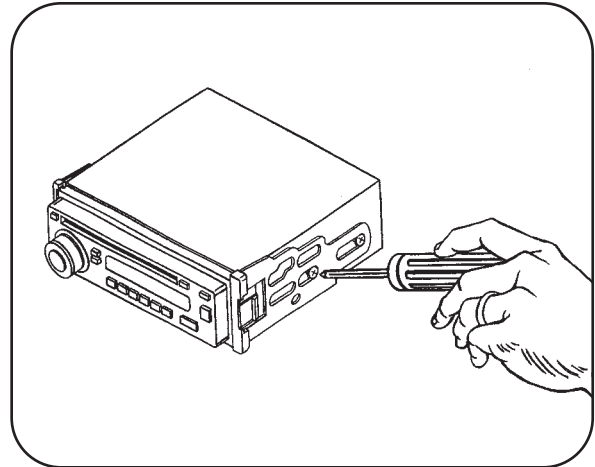

B

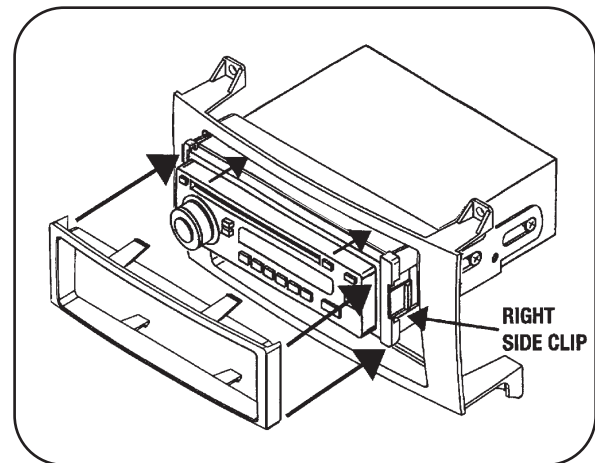

C

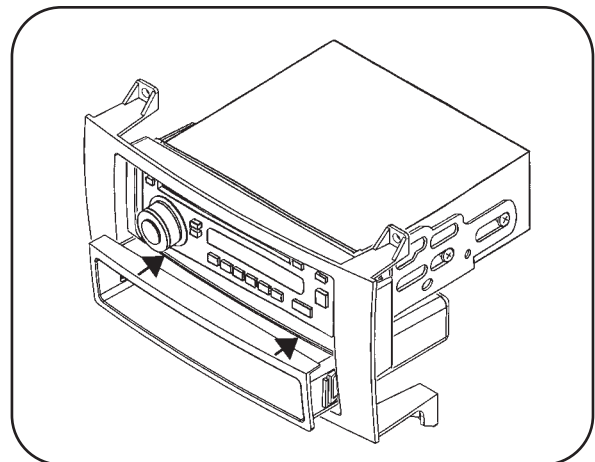

DOUBLE DIN RADIO PROVISION

Note: Refer also to the instructions included with the aftermarket radio.

- 1** Cut and remove the center bar from the Radio Housing. (Figure A)
- 2** Snap the Double DIN brackets to the inside edge of the radio housing. (Figure B)
- 3** Slide the Double DIN radio into the Double DIN bracket/radio housing assembly and secure the radio to the kit using the screws supplied with the radio. (Figure C)
- 4** Snap the Double DIN trim-plate over the front of the housing/radio assembly. (Figure C)

Continue to final assembly.

A

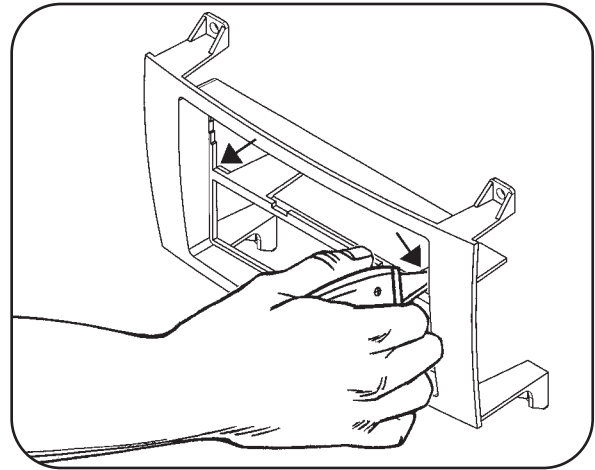

B

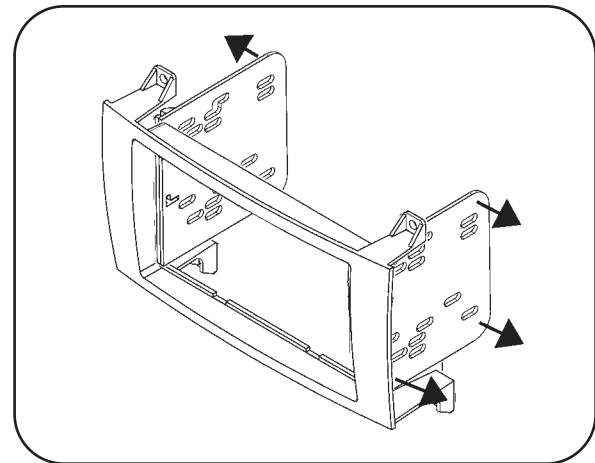

C

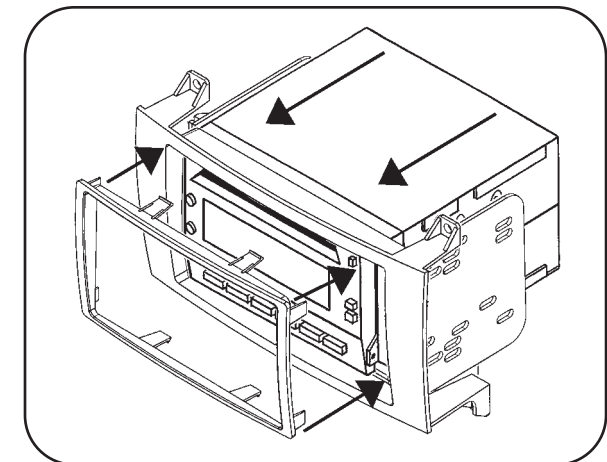

STACKED ISO UNITS PROVISION

Note: Refer also to the instructions included with the aftermarket radio.

- 1** Cut and remove the center bar from the radio housing. (Figure A)
- 2** Snap the Double DIN brackets to the inside edge of the radio housing. (Figure B)
- 3** Slide the stacked ISO units into the Double DIN bracket/radio housing assembly and secure the units to the kit using the screws supplied with the units. (Figure C)
- 4** Snap the Double DIN trim-plate over the front of the assembled Radio Housing and stacked ISO units. (Figure C)

Continue to final assembly.

A

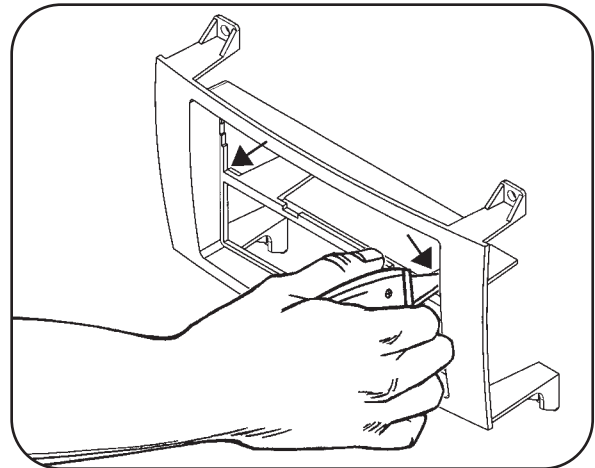

B

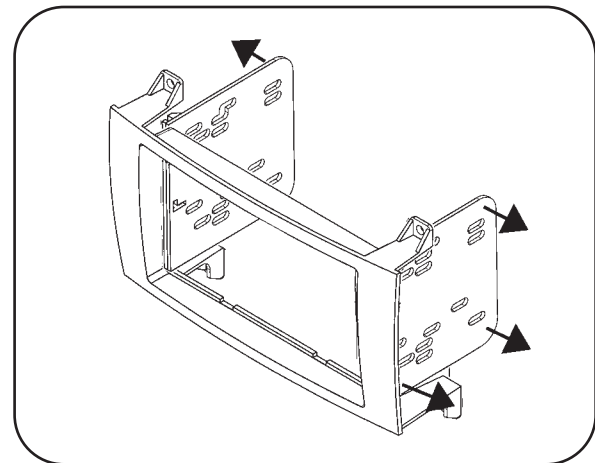

C

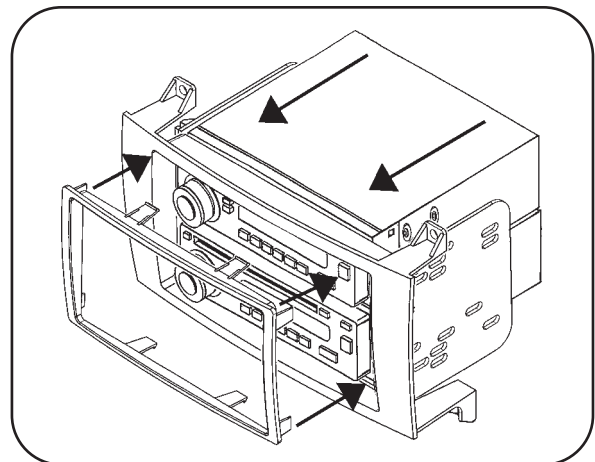

FINAL ASSEMBLY

- 1 Locate the factory wiring harness in the dash and make the connection as shown. Metra recommends using the proper mating adapter and making the connections as shown. (Isolate and individually tape off the ends of any unused wires to prevent electrical short circuit.)
- 2 Re-connect the negative battery terminal and test the unit for proper operation.
- 3 Reassemble radio and dash assemblies in reverse order of disassembly.

FINAL WIRING CONNECTIONS

Make wiring connections using the EIA color code chart shown below and the instructions included with the head unit. Metra recommends making connections as shown below; Strip, Splice, Solder, Tape. Isolate and individually tape off ends of any unused wires to prevent electrical short circuit.

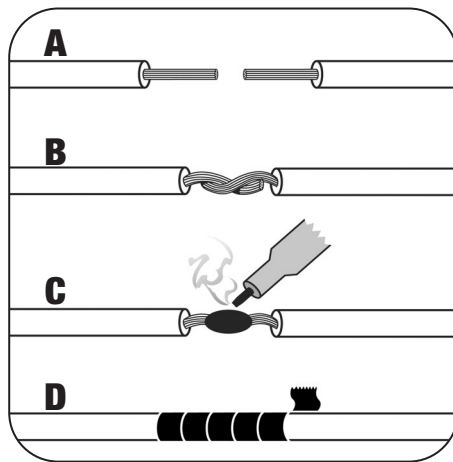

- A) Strip wire ends back 1/2"**
- B) Twist ends together**
- C) Solder**
- D) Tape**

METRA / EIA WIRING CODE

12V Ignition / Acc . . . Red	Right Front (+) Gray
12V Batt / Memory . . . Yellow	Right Front (-) Gray / Black
Ground Black*	Left Front (+) White
Power Antenna Blue	Left Front (-) White / Black
Amp Turn-On Blue / White	Right Rear (+) Violet
Amp Ground Black / White	Right Rear (-) Violet / Black
Illumination Orange	Left Rear (+) Green
Dimmer Orange / White	Left Rear (-) Green / Black

***NOTE:** When Black a wire is not present, ground radio to vehicle chassis.

All colors may not be present on all leads due to manufacturer's specifications.

99-8713 INSTRUCTIONS



1-800-221-0932



www.metraonline.com

REV. 04/23/10

© COPYRIGHT 2004-2010 METRA ELECTRONICS CORPORATION

INST99-8713