

INSTALLATION INSTRUCTIONS

VIKING RANGE CORPORATION
111 Front Street
Greenwood, Mississippi (MS) 38930 USA
(662) 455-1200



FREESTANDING GAS RANGES

IMPORTANT - PLEASE READ AND FOLLOW

- Before beginning, please read these instructions completely and carefully.
- Do not remove permanently affixed labels, warnings, or plates from the product. This may void the warranty.
- Please observe all local and national codes and ordinances.
- Please ensure that this product is properly grounded.
- The installer should leave these instructions with the consumer who should retain for local inspector's use and for future reference.
- The electrical plug should always be accessible.

Installation must conform with local codes or in the absence of codes, the National Fuel Gas Code ANSI Z223.1-latest edition. Electrical installation must be in accordance with the National Electrical Code, ANIS/NFPA70 - latest edition and/or local codes. IN CANADA: Installation must be in accordance with the current CAN/CGA-B149.1 National Gas Installation Code or CAN/CGA-B149.2, Propane Installation Code and/or local codes. Electrical installation must be in accordance with the current CSA C22.1 Canadian Electrical Codes Part 1 and/or local codes.

Installation of any gas-fired equipment should be made by a licensed plumber. A manual gas shut-off valve must be installed in the gas supply line ahead of the oven in the gas stream for safety and ease of service.

In Massachusetts: All gas products must be installed by a "Massachusetts" licensed plumber or gasfitter. A "T" handle type manual gas valve must be installed in the gas supply line to this appliance.

	<p style="text-align: center;">WARNING!</p> <ul style="list-style-type: none">• This range can tip.• Injury to persons could result.• Install anti-tip device packed with range.• See Installation Instructions
---	---

<p>WARNING: IF THE INFORMATION IN THIS MANUAL IS NOT FOLLOWED EXACTLY, A FIRE OR EXPLOSION MAY RESULT CAUSING PROPERTY DAMAGE, PERSONAL INJURY, OR DEATH.</p> <ol style="list-style-type: none">1. Do not store or use gasoline or other flammable vapors and liquids in the vicinity of this or any other appliance.2. WHAT TO DO IF YOU SMELL GAS:<ul style="list-style-type: none">• Do not try to light any appliance.• Do not touch any electrical switch; do not use any phone in your building.• Immediately call your gas supplier from a neighbor's phone.• Follow the gas supplier's instructions.• If you cannot reach your gas supplier, call the fire department.3. Installation and service must be performed by a qualified installer, service agency, or the gas supplier.
--

<p style="text-align: center;">WARNING</p> <p>If not installed, operated and maintained in accordance with the manufacturer's instructions, this product could expose you to substances in fuel or from fuel combustion which can cause death or serious illness and which are known to cause cancer, birth defects, or other reproductive harm.</p> <p>For example, benzene is a chemical which is part of the gas supplied to the cooking product. It is consumed in the flame during combustion. However exposure to a small amount of benzene is possible if a gas leak occurs. Formaldehyde and soot are by-products of incomplete combustion. Properly adjusted burners with a bluish rather than yellow flame will minimize incomplete combustion.</p>
--

GENERAL INFORMATION

1. **WARNING:** The use of cabinets for storage above the appliance may result in a potential burn hazard. Combustible items may ignite, metallic items may become hot and cause burns. If a cabinet storage is to be provided the risk can be reduced by installing a rangehood that projects horizontally a minimum of 5" (12.7 cm) beyond the bottom of the cabinets.
2. **WARNING:** This appliance shall not be used for space heating. This information is based on safety considerations.
3. All openings in the wall behind the appliance and in the floor under the appliance shall be sealed.
4. Keep appliance area clear and free from combustible materials, gasoline, and other flammable vapors.
5. Do not obstruct the flow of combustion and ventilation air.
6. Disconnect the electrical supply to the appliance before servicing.
7. When removing oven for cleaning and/or service;
 - A. Shut off gas at main supply
 - B. Disconnect AC power supply
 - C. Disconnect gas line to the inlet pipe.
 - D. Carefully remove the range by pulling outward. **CAUTION:** Range is heavy; use care in handling.
8. Electrical Requirement
Listed on Specification sheet. Electrical installation should comply with national and local codes.
9. Gas Manifold Pressure
Natural gas 5.0" W.C.P.
LP/Propane 10.0" W.C.P.
10. Ventilation
It is recommended that the unit be set under a powered, vented exhaust hood or downdraft of sufficient size and capacity. If the unit incorporates a char-grill feature, the unit **must** be used in conjunction with a powered, vented exhaust hood of sufficient size and capacity.
11. Flexible Connections:
If this unit is to be installed with flexible couplings and/or quick disconnect fittings, the installer must use a flexible connector approved by national and local codes.
12. The misuse of oven doors (e.g. stepping, sitting, or leaning on them) can result in potential hazards and/or injuries.

When installing or removing the range for service, a rolling lift jack should be used. Do not push against any of the edges of the range in an attempt to slide it into or out of the installation. Although all metal parts are deburred during manufacturing, accidents could occur if the range should be moved suddenly or violently. Pushing or pulling a range (rather than using a lift jack) also increases the possibility of bending the leg spindles or the internal coupling connectors.

WARNING!!

ELECTRICAL GROUNDING INSTRUCTIONS

This range must be electrically grounded in accordance with local codes, or in the absence of local codes, with the National Electrical Code, ANSI/NFPA70-latest edition. This appliance is equipped with 3-prong plug for your protection against shock hazard and should be plugged directly into a properly grounded socket. Do not cut or remove the grounding prong from this plug.

FOR PERSONAL SAFETY, THIS APPLIANCE MUST BE PROPERLY GROUNDED

Legs

1. Legs are packed in styrofoam top pack.
2. Legs should be installed near to where the appliance is to be used, as they are not secure for long transit. After unpacking the range, raise it about a foot to remove the bottom shipping skid. Keep the unit raised to permit the legs to be screwed into our couplings and lower it gently to keep any undue strain from the legs and internal mounting hardware. It is strongly recommended that a pallet or lift jack be used rather than tilting.

NOTE: If legs are removed from range and range rests on a combustible surface, warranty and CE certification are void.

BACK TRIM ACCESSORIES

Assembly and installation instructions are included with all back trim accessories.

ANTI-TIP STABILITY DEVICE INSTALLATION INSTRUCTIONS

1. The anti-tip bracket is to be attached to the rear wall as shown. The dimension for the bracket location from the floor is to be determined after the range legs have been adjusted to the proper installation height shown in the installation instructions and the range has been leveled.
2. Measure from the floor to the bottom of the anti-tip opening located on the back of the range.
3. Locate the anti-tip bracket on the wall at the measure dimension plus 1/16" (0.16 cm) clearance and attach securely with provided toggle bolts.
4. Slide range into place. Be sure the bottom rear flange on the rear of the range slides under the bracket attached to the rear wall.

Item "A"

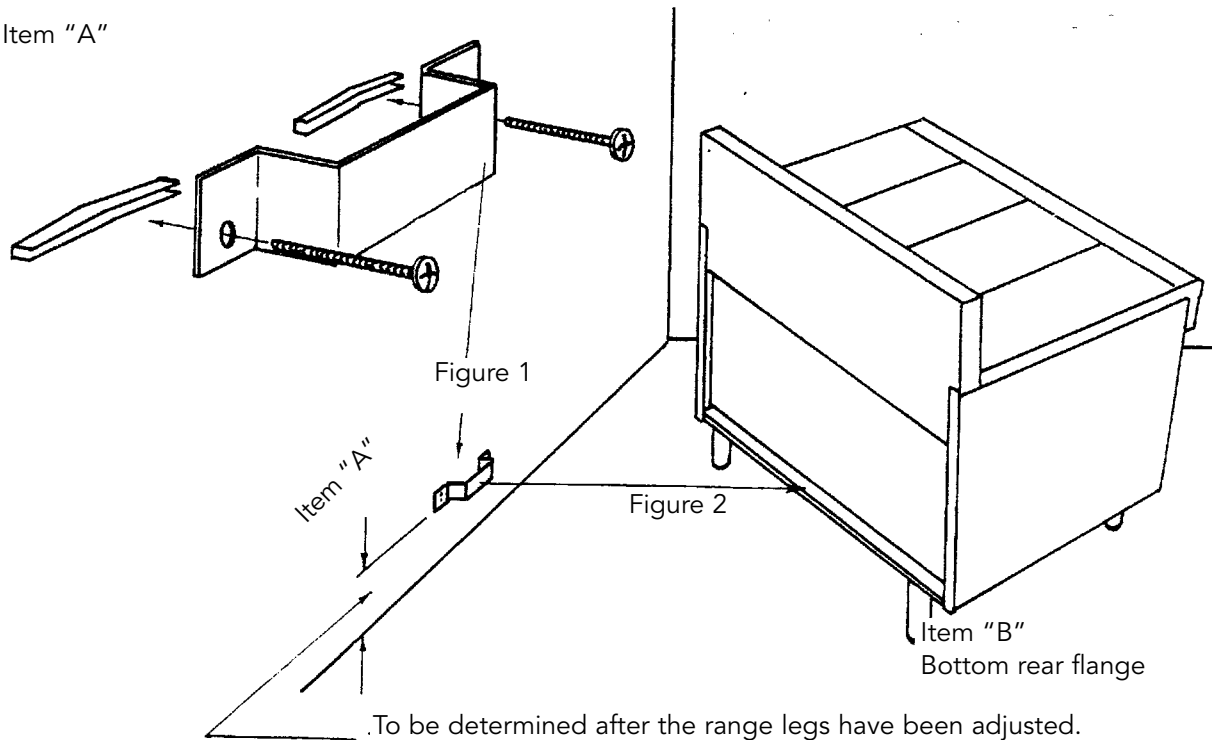

RANGES EQUIPPED WITH CASTERS

1. Adequate means must be provided to limit the movement of castered ranges without depending on the connector and/or quick disconnect device. This "restraint" should be inspected as part of the maintenance and safety procedure. Restraint cable must be connected at all times when range is in use.
2. When using the quick disconnect device and/or casters, the "restrainer" must be attached to the wall and to the rear of the range.
3. If disconnection of the restraint is necessary, ensure the restraint is reconnected after the range has been returned to its original position.

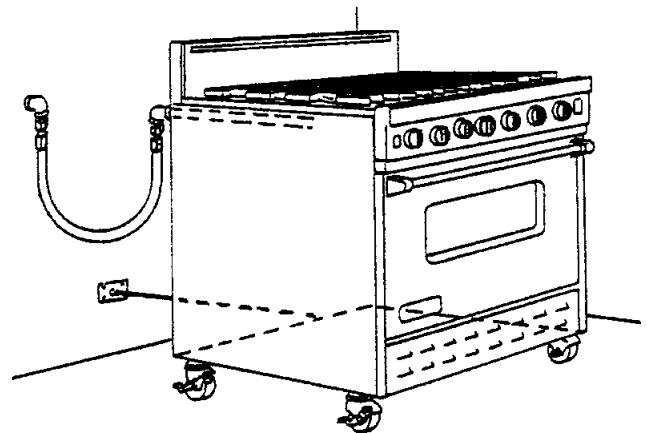

PROXIMITY TO SIDE CABINET INSTALLATION (30" W., 36" W., 48" W., 60" W. MODELS)

1. This range may be installed directly adjacent to existing 36" (91.4 cm) high base cabinets. **IMPORTANT:** The top grate support **MUST** be 3/8" (.95 cm) above the adjacent base cabinet countertop. This may be accomplished by raising the unit using the adjustment spindles on the legs.
2. The range **CANNOT** be installed directly adjacent to sidewalls, tall cabinets, tall appliances, or other side vertical surfaces above 36" (91.4 cm) high. There must be a minimum of 6" (15.2 cm) side clearance from the range to such combustible surfaces above the 36" (91.4 cm) counter height.
3. Within the 6" (15.2 cm) side clearance to combustible vertical surfaces above 36" (91.4 cm), the maximum wall cabinet depth must be 13" (33.0 cm) and wall cabinets within this 6" (15.2 cm) side clearance must be 18" (45.7 cm) above the 36" (91.4 cm) high countertop.
4. Wall cabinets above the range must be a minimum of 36" (91.4 cm) for open top burners and a minimum of 42" (106.7 cm) for sealed burner models above the range cooking surface for the full width of the range. This minimum height requirement does not apply if a rangehood is installed over the cooking surface.

	Dim. A
30" W. Models	29 7/8" (75.9 cm)
36" W. Models	35 7/8" (91.1 cm)
48" W. Models	47 7/8" (121.6 cm)
60" W. Models	59 1/2" (151.1 cm)

	Dim. B (minimum)
Open Top Burners	36" (91.4 cm)
Sealed Burners	42" (106.7 cm)

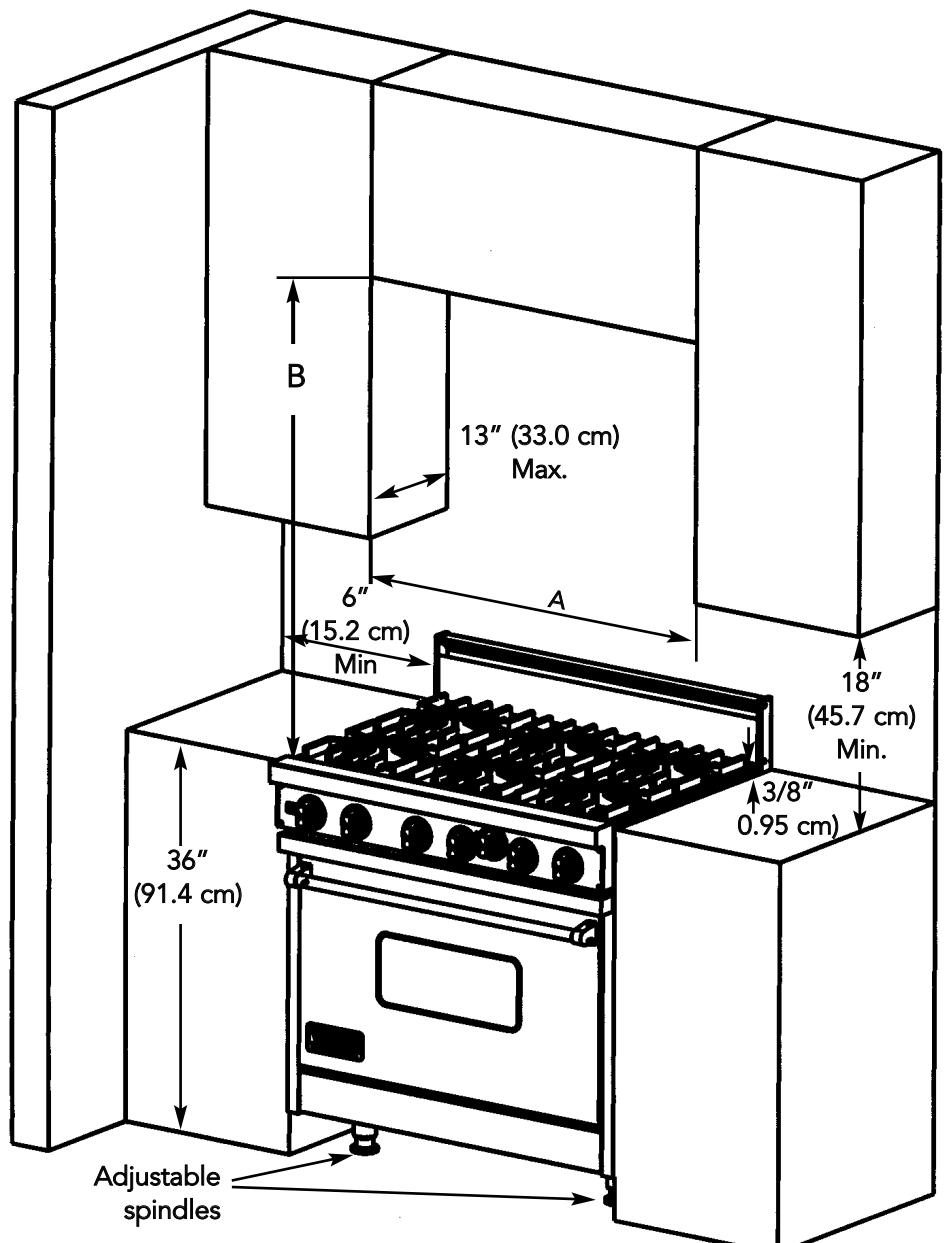

PROXIMITY TO SIDE CABINET INSTALLATION (24" W. MODELS)

1. This range may be installed directly adjacent to existing 36" (91.4 cm) high base cabinets. **IMPORTANT:** The top grate support **MUST** be 3/8" (.95 cm) above the adjacent base cabinet countertop. This may be accomplished by raising the unit using the adjustment spindles on the legs.
2. The range **CANNOT** be installed directly adjacent to sidewalls, tall cabinets, tall appliances, or other side vertical surfaces above 36" (91.4 cm) high. There must be a minimum of 6" (15.2 cm) side clearance for the 4-Burner and Griddle model ranges and a minimum of 9" (22.9 cm) side clearance for the Char-Grill model to such combustible surfaces above the 36" (91.4 cm) counter height.
3. Within the side clearance to combustible vertical surfaces above 36" (91.4 cm), the maximum wall cabinet depth must be 13" (33.0 cm) and wall cabinets within this side clearance must be 18" (45.7 cm) above the 36" (91.4 cm) high countertop.
4. Wall cabinets above the range must be a minimum of 42" (106.7 cm) above the range cooking surface for the full width of the range. This minimum requirement does not apply if a rangehood is installed over the cooking surface.

A	
4B Model	6" (15.2 cm)
G Model	6" (15.2 cm)
K Model	6" (15.2 cm)
Q Model	9" (22.9 cm)

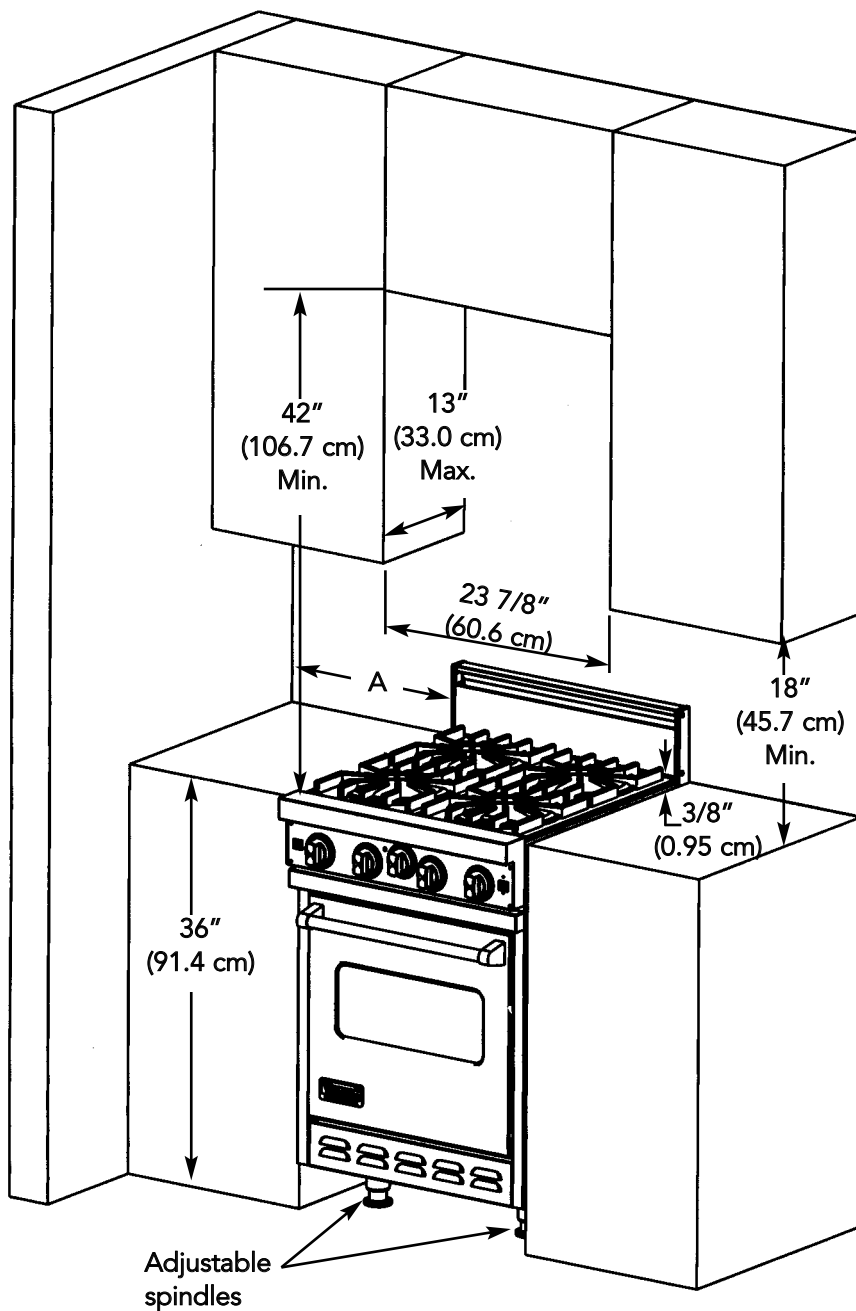

WOOD/COMPOSITE OVERLAY INSTALLATION

The bottom of the hood should be 30" (76.2 cm) min. to 36" (91.4 cm) above the countertop. This would typically result in the bottom of the hood being 66" (167.6 cm) to 72" (182.9 cm) above the floor. Refer to the rangehood installation instructions for additional information. These dimensions provide for safe and efficient operation of the hood.

WALL INSTALLATION

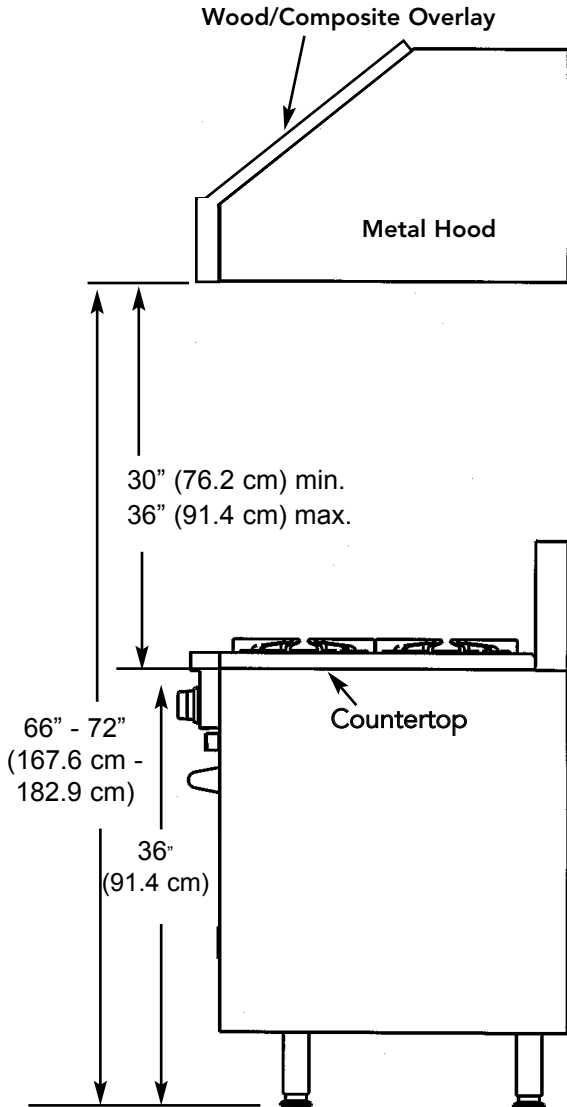

ISLAND INSTALLATION

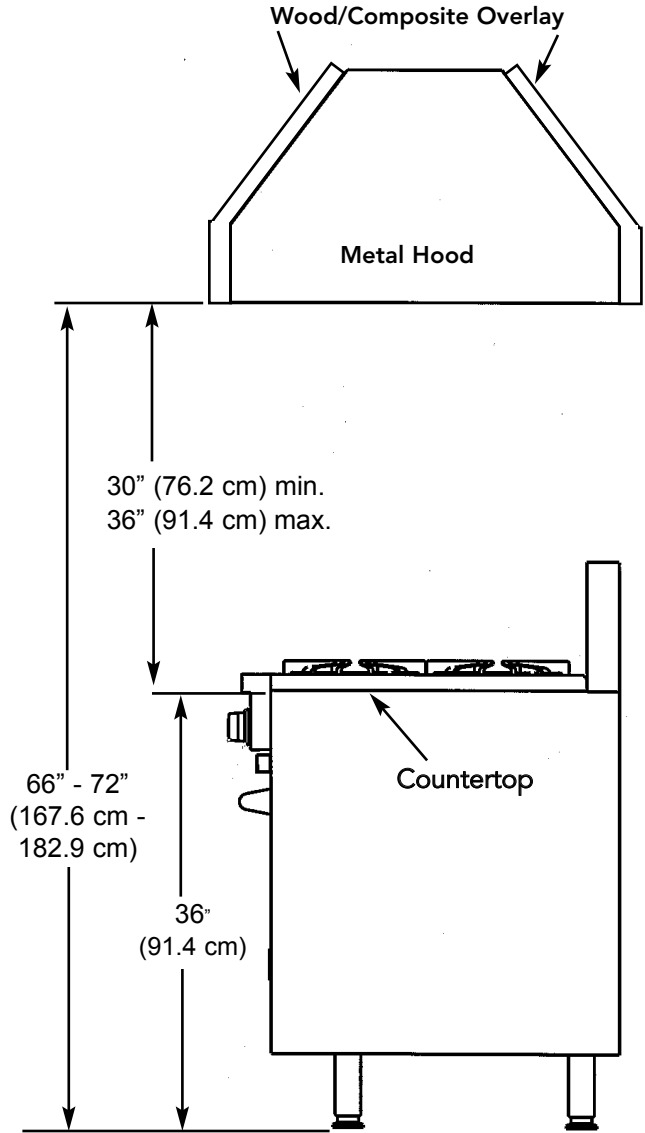

IMPORTANT: LEVELING/ADJUSTMENTS/ALIGNMENT

Careful leveling of the range is critical not only to performance, but also to allow the alignment of oven doors and drip tray. Closely follow the procedures below to ensure proper performance and appearance of the range. **The range being even slightly out of level will significantly contribute to misalignment of oven doors.**

1. If the floor is smooth and level, level the unit with the screw thread of the legs. Set the high corner of the range so that the top of the grate support is 3/8" (.95cm) above the countertop, and level the range to the high corner.
2. If the floor is uneven or has a decided slope, level the unit with metal shims, as the adjustment required may exceed the thread available in the leg.
3. Proper and careful leveling of the range is necessary for proper alignment of the oven doors. The body of the range does not have a rigid frame to hold it into one position. This nonrigid framework allows the range to shift with unlevel floors or slanted cabinets. Moving any one of the adjustable leveling legs up or down will shift the range body. Increasing the length of the right front leveling leg will raise the right front corner of the range, moving the top of the door to the left. Lowering the right front leveling leg will cause the tip of the door to move to the right. Using the left front leveling leg will give you the opposite effect. Raising the left front corner will move the top of the door to the right. Lowering the corner will move the top of the door to the left. The rear leveling legs will also have an effect on the door alignment.
3. After the range is properly leveled, the drip tray handle may be aligned by loosening the screws and adjusting the handle horizontally within the limits provided by the slotted screw holes.
4. A level should be placed across the top of the range and the unit leveled both front-to-back and side-to-side. If it is not level, burner combustion may be erratic, liquid, or semi-liquid batters will cook at an angle, and the unit may not function efficiently.

- A. Right Side
Front / Back
Adjustable Legs
- B. Left Side
Front / Back
Adjustable Legs

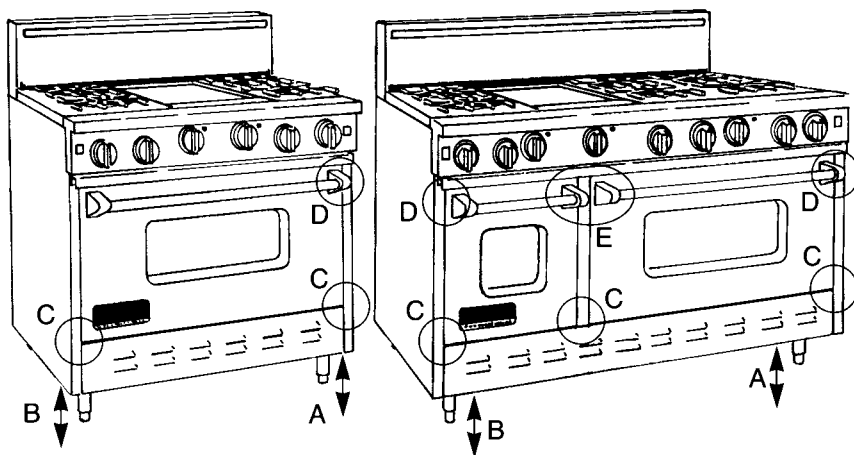

- A. Right Side
Front / Back
Adjustable Legs
- B. Left Side
Front / Back
Adjustable Legs
- C. Door Hinge
- D. Spacing between
edge of door and
side panel
- E. Center trim
spacing

ELECTRICAL CONNECTION

This unit is manufactured for a polarized, grounded 120 volt/60 Hz, 16 amp circuit. The minimum of 102 VAC is required for proper operation of gas ignition systems. This circuit must be grounded and properly polarized. Do not use GFI circuit. The unit is equipped with a 16-3 SJT power cord, and if an extension is required, it must be of at least this gauge.

NOTE: If electrical power is not supplied or is interrupted, the oven, griddle, and the broiler will not work at all. The surface burners and grill burner will have to lit manually with a match.

WARNING!!

Electrical Grounding Instructions

This appliance is equipped with a three prong plug for your protection against shock hazard and should be plugged directly into a properly grounded socket. Do not cut or remove the grounding prong from this plug

GAS CONNECTION

All gas connections must be made according to national and local codes. This gas supply (service) line must be the same size or greater than the inlet line of the appliance. This range uses a 1/2" NPT (Sch 40) inlet. Sealant on all pipe joints must be resistive to LP gas.

1. Manual Shut-off Valve:

This installer-supplied valve must be installed in the gas service line ahead of the appliance in the gas stream and in a position where it can be reached quickly in the event of an emergency. **In Massachusetts:** A "T" handle type manual gas valve must be installed in the gas supply line to this appliance.

2. Pressure Regulator

- All heavy duty, commercial type cooking equipment must have a pressure regulator on the incoming service line for safe and efficient operation, since service pressure may fluctuate with local demand. External regulators are not required on this range, because a regulator is built into each unit at the factory. Under no condition bypass this built-in regulator.
- Any conversion required must be performed by your dealer or a qualified licensed plumber or gas service company. Please provide the service person with this manual before work is started on the range. (Gas conversions are the responsibility of the dealer or end user.)
- This range can be used with Natural or LP/Propane gas. It is shipped from the factory adjusted for use with natural gas. The orifice hoods must be screwed snug when LP/Propane gas is used. (See LP/Propane conversion.)
- Manifold pressure should be checked with a manometer, natural gas requires 5.0" W.C.P. and LP/Propane requires 10.0" W.C.P. Incoming line pressure upstream from the regulator must be 1" W.C.P. higher than the manifold pressure in order to check the regulator. The regulator used on this range can withstand a maximum input pressure of 1/2 PSI (14.0" W.C.P.) If the line pressure is in excess of that amount, a step-down regulator will be required.
- The appliance, its individual shut-off valve, and pressure regulator must be disconnected from the gas supply piping system during any pressure testing of that system at pressures in excess of 1/2 psig (3.45 kPa).
- The appliance must be isolated from the gas supply piping system by closing its individual manual shut-off valve during any pressure testing of the gas supply piping system at test pressures equal to or less than 1/2 psig (3.45 kPa).

3. Flexible Connections:

- If the unit is to be installed with flexible couplings and/or quick disconnect fittings, the installer must use a heavy-duty, AGA design-certified commercial flexible connector of at least 1/2" (1.3 cm) ID NPT (with suitable strain reliefs) in compliance with ANSI Z21.41 and Z21.69 standards.
- In Massachusetts:** The unit must be installed with a 36" (3-foot) long flexible gas connector.
- In Canada:** CAN 1-6.10-88 metal connectors for gas appliances and CAN 1-6.9 M79 quick disconnect device for use with gas fuel.

CAUTION: Leak testing of the appliance shall be conducted according to the manufacturer's instructions. Before placing the oven into operation, always check for leaks with a soapy water solution of other acceptable method. **DO NOT USE AN OPEN FLAME TO CHECK FOR LEAKS!**

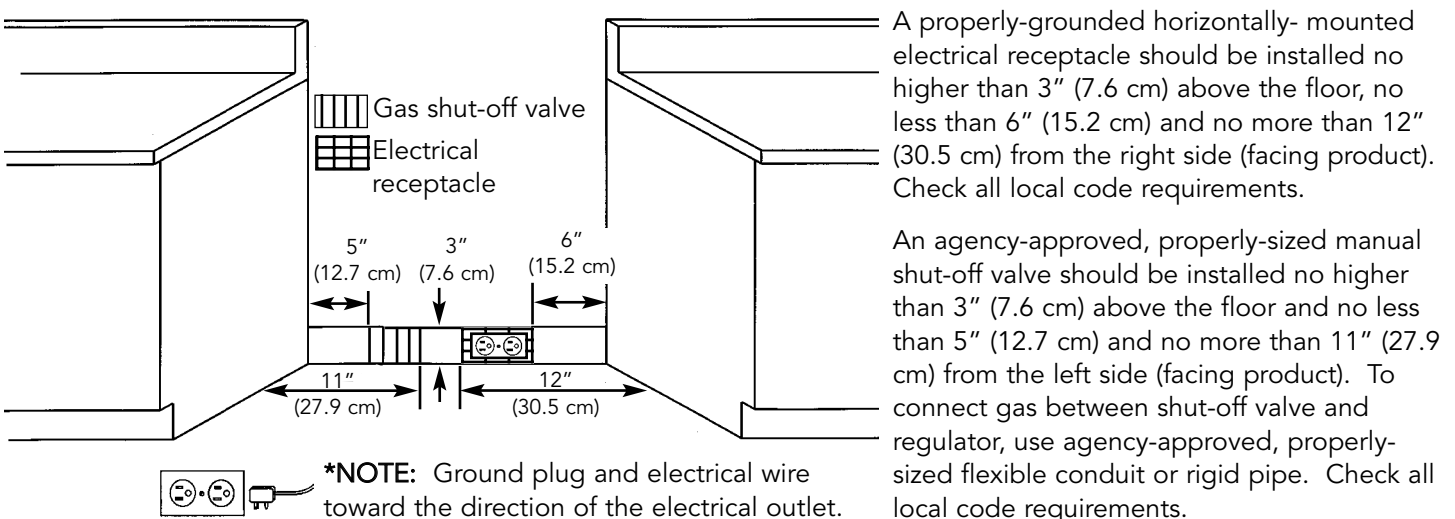

A properly-grounded horizontally-mounted electrical receptacle should be installed no higher than 3" (7.6 cm) above the floor, no less than 6" (15.2 cm) and no more than 12" (30.5 cm) from the right side (facing product). Check all local code requirements.

An agency-approved, properly-sized manual shut-off valve should be installed no higher than 3" (7.6 cm) above the floor and no less than 5" (12.7 cm) and no more than 11" (27.9 cm) from the left side (facing product). To connect gas between shut-off valve and regulator, use agency-approved, properly-sized flexible conduit or rigid pipe. Check all local code requirements.

NATURAL TO LP/PROPANE CONVERSION INSTRUCTIONS

(For Open Surface Burners)

This product is manufactured and adjusted for operation with natural gas as shipped from the factory. To operate with LP/Propane gas, the following adjustments should be made.

1. A pressure regulator is located in the left rear corner of the burner box. To gain access to the pressure regulator, remove the two left grates, two burner bowls, and the left grate support. Convert the regulator by removing the cap marked "NAT" and reverse it to read "LP". Be sure not to disturb or remove the spring beneath the cap.
 2. To convert surface, griddle, grill, and bake burners (for 30", 36", 48", and 60" W. models) to LP/Propane, turn the burner orifice hoods clockwise until the hood becomes snug against the internal LP/Propane pin orifice.
 3. The orifice spud for the infrared broil burner and bake burner for 24" W. model has to be physically changed. To convert the infrared burner, remove the #47 orifice spud and replace with the #56 orifice spud that is found in the left rear corner of the burner box next to the regulator below the top burners. For the 24" W. model, remove the infrared broil orifice spud #50 and replace with the #57 infrared orifice spud. To convert the bake burner, remove the #31 orifice that is shipped in the bake burner. Replace with the #50 bake burner orifice spud that is found in the left rear corner of the burner box next to the regulator below the top burners. Place all natural gas orifice spuds where the LP orifice spuds were located for future use should the product need to be converted back to natural gas.
- See the "Gas Burner Adjustment" section to obtain a properly adjusted flame for all burners.

NATURAL TO LP/PROPANE CONVERSION INSTRUCTIONS

(For Sealed Surface Burners)

This product is manufactured and adjusted for operation with natural gas as shipped from the factory. **CAUTION:** Before proceeding with conversion, turn off gas supply to the appliance and disconnect the electrical power.

To operate with LP/Propane gas, the following adjustments should be made:

1. Remove the surface grates.
2. Remove the burner cap (Item#1) and the burner head (Item#2) by lifting up.
3. Remove the venturi (Item#3).
4. Use a 11/32" (0.9 cm) socket or nut driver to remove orifice (Item#4) and replace it with LP orifices located next to the pressure regulator. (See Figure 2) Save the natural gas orifice for future use.
5. Replace the venturi (Item#3) and hand tighten. Replace the burner head (Item#2), the burner cap (Item#1) and the surface grates.
6. To convert surface, griddle, and grill burners to LP/Propane, turn the burner orifice hoods clockwise until they become snug against the internal LP/Propane pin orifice.
7. A pressure regulator is located in the left rear corner of the burner box. To gain access to the pressure regulator, remove the backguard. Convert the regulator by removing the cap marked "Nat" and reverse it to read "LP". Be sure not to disturb or remove the spring beneath the cap.
8. Manifold pressure should be checked with a manometer. LP/Propane requires 10.0" W.C.P. Incoming line pressure upstream from the regulator must be 1" W.C.P. higher than the manifold pressure.

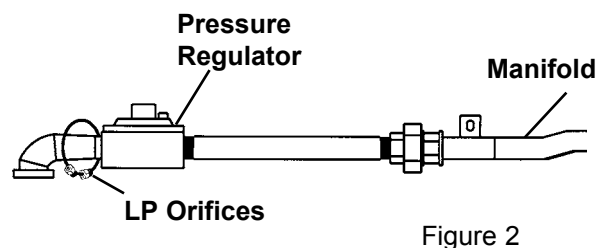
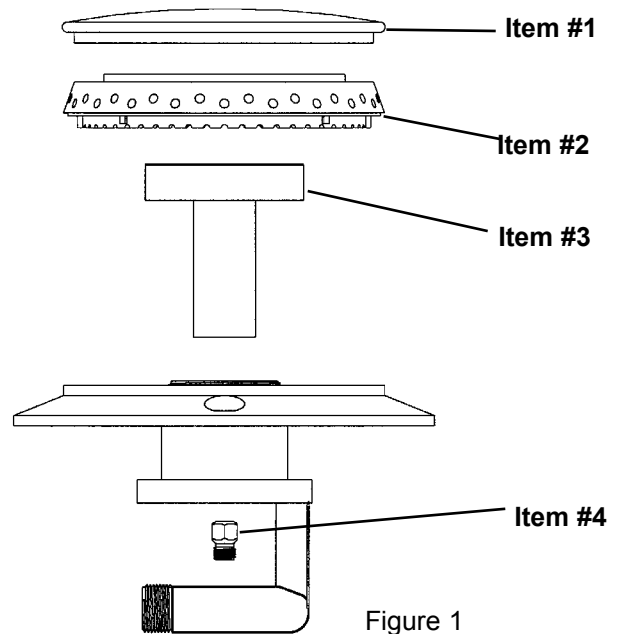

INFRARED BROIL BURNER

1. An electric ignitor is used to light the burner.. DO NOT attempt to insert any object into the openings of the protective shield surrounding the ignitor coil. DO NOT attempt to clean this area.
2. UNIVERSAL Models (NAT. or LP) are shipped from the factory orificed for Natural Gas. IF THEY ARE TO BE USED ON LP/PROPANE GAS, the burner orifice spud must be changed. (This will be found attached to the inlet pipe). BE SURE to use the proper burner spud for the gas in use.
3. **BEFORE PLACING THE BACK TRIM DEVICE ON THE RANGE AND BEFORE PLACING THE RANGE INTO THE CABINET, THE INFRARED BURNER SPUD MUST BE PHYSICALLY CHANGED.**

OVEN TUBULAR GAS BURNER ADJUSTMENTS (REFER TO ILLUSTRATION #1)

To gain access to the oven burner adjustments:

1. remove the kick plate - remove screw from each side of kick plate and tilt the top of the kick plate forward.
2. Locate the air shutter (illustration #1, Item 1) and loosen the set screw (Illustration #1, Item 2) that holds the air shutter in place.
3. Light the burners by rotating the thermostat to a baking temperature.
4. Using a 1/2" (1.3 cm) open-end wrench, adjust orifice hood (Illustration #1, Item 3) to obtain a sharp, well defined blue inner once approximately 1/2" (1.3 cm) long. The flame should be contacting the burner at each port opening. THE FLAME SHOULD NOT EXTEND INTO THE OVEN BOTTOM VENT SLOTS,
5. With a proper flame height, adjust the air shutter (illustration #1, Item 1) to obtain a blue flame with no yellow tipping that contacts the burner at the burner ports.
 - a. Open the air shutter gap (Illustration #1, Item 1) to eliminate yellow tipping.
 - b. Close the air shutter gap (Illustration #1, Item 1) to prevent a noisy flame that lifts off the burner.
6. Recheck the orifice hood (Illustration #1, Item 3) adjustment for proper gas flow.
7. Turn the thermostat off.
8. Tighten the air shutter set screw (illustration #1, Item 2).
9. Relight each burner and observe the flame for proper adjustments. If necessary, repeat the above.
10. Replace the kick plate.

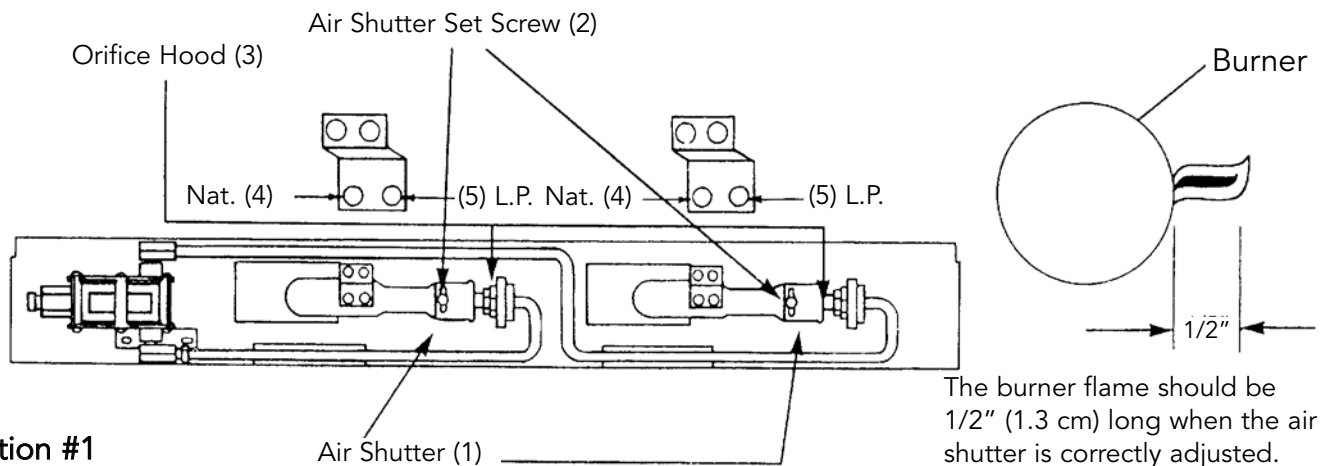

Illustration #1

SURFACE BURNER ADJUSTMENTS (For Open Surface Burners)

(See Illustration #2)

To gain access to the surface burner adjustments:

1. Remove the grates, burner caps, bowls and grate supports.
2. Located the air shutter (A) and loosen the screw (B) that holds the air shutter in place.
3. Remove the drip tray, allowing you work space to adjust the orifice hood (C).
4. Replace grate support and burner bowls (this allows for correct air flow, as in normal use).
5. Light each burner by rotating the burner valve shaft (D) to high position.
6. With a proper flame height, adjust the air shutter (A) to obtain a blue flame with no yellow tipping that sits on the burner at the burner ports.
 - a) Open the air shutter gap to eliminate yellow tipping.
 - b) Close the air shutter gap to prevent a noisy flame that lifts off the burner.
7. Turn the surface burners off.
8. Replace the drip tray.
9. Remove grate support and burner bowls.
10. Tighten the air shutter screw (B) being careful to not change the adjusted shutter gap.
11. Replace the grate supports, burner bowls, burner caps, and grates.
12. Turn the lighted burners to the low flame setting.
13. Insert a narrow, flat-blade screwdriver into the hollow shaft of the surface burner valve, and engage the slotted low flame adjustment screw. The low flame should be a small flame that comes just to the top edge of the burner. Rotate the adjusting screw (E) clockwise to lower the flame or counter clockwise to increase the flame. Turn the burner off and relight several times, turning to the low position. The low flame should light at every port each time. Readjust as needed.

SURFACE BURNER ADJUSTMENTS (For Sealed Surface Burners)

(See Illustration #2)

1. Turn the lighted burners to the low flame setting.
2. Insert a narrow, flat-blade screwdriver into the hollow shaft of the surface burner valve, and engage the slotted low flame adjustment screw. The low flame should be a small flame that comes just to the top edge of the burner. Rotate the adjusting screw (E) clockwise to lower the flame or counter clockwise to increase the flame. Turn the burner off and relight several times, turning to the low position. The low flame should light at every port each time. Readjust as needed.

Illustration #2

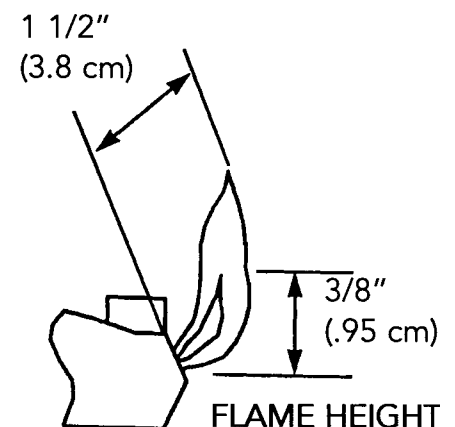
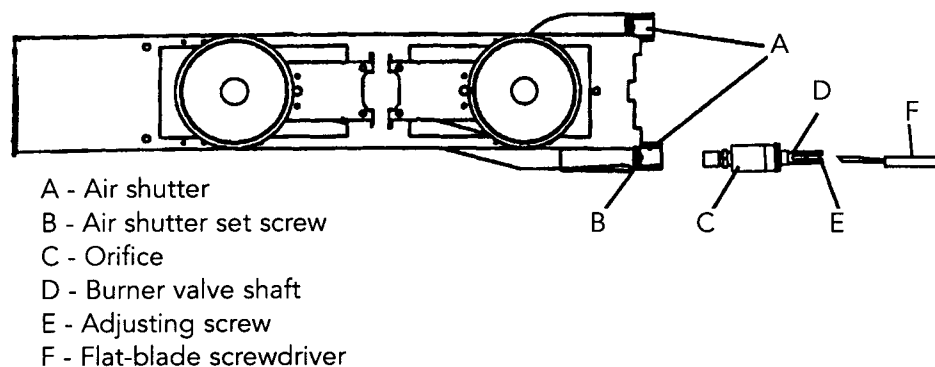

WOK BURNER ADJUSTMENTS

To gain access to the burner for adjustments:

1. Remove the grate and grate support.
2. Locate the air shutter "A" and loosen the two screws "B" that holds the air shutter in place.
3. Light the burner and turn the burner knob to the high position.
4. With a proper, high flame height, adjust the air shutter to obtain a blue flame with no yellow tipping that sits on the burner at the burner ports.
 - (a) open the air shutter gap to add more air and to eliminate yellow tipping.
 - (b) close the air shutter gap to reduce the air and to prevent a noisy flame that lifts off the burner.
5. Turn the surface burners off.
6. Tighten the air shutter screws.
7. Replace the grate support and grate.

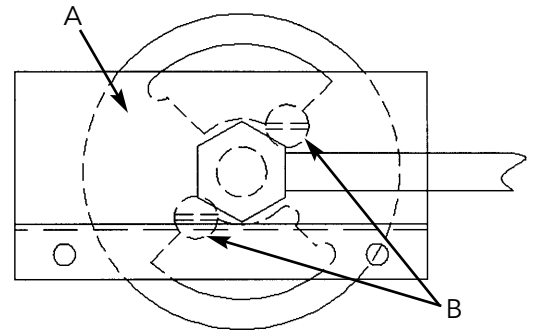

AIR SHUTTER

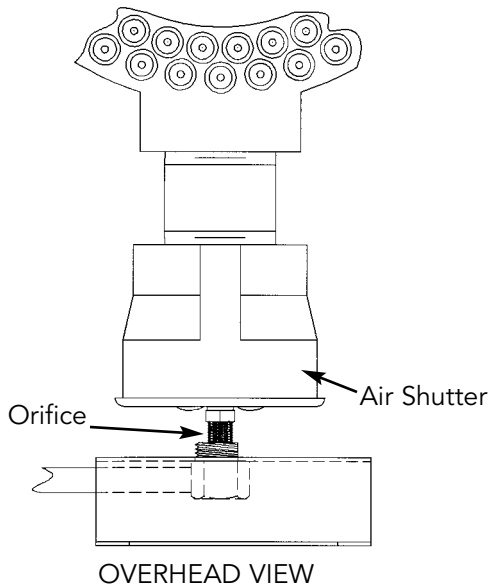

OVERHEAD VIEW

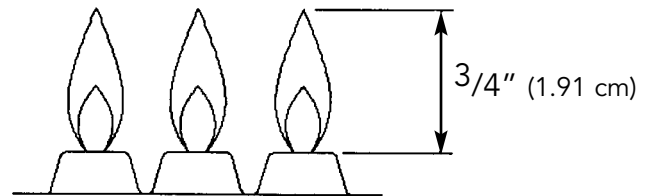

FLAME HEIGHT

GRILL/GRIDDLE BURNER ADJUSTMENT

Grill

1. The grill burner orifice and air shutter are located beneath the front end of the grill assembly. To gain access to the adjustment, remove the grill grate, grate support, flame spreaders, and the burner shield.
2. Remove the screw at the front and rear of the burner.
3. Lift the burner off the orifice and locate the air shutter adjustment screw at the end of the burner.
4. Loosen the screw and adjust the air shutter to the desired setting [for natural gas open shutter approximately 3/8" (.95 cm); for LP gas open the air shutter approximately 7/16" (1.1 cm)].
5. Tighten the screw, then replace the burner on the orifice.
6. Check the flame for desired height before replacement of the above parts.
7. The flame adjustments are the same as the surface burners. Use a 1/2" (1.3 cm) deep socket to adjust the orifice head; turn clockwise to decrease flame and counter clockwise to increase flame.

Griddle

1. To gain access to the burner orifice and air shutter, remove grates and grate supports located on either side of the griddle. Lift and remove the griddle.
2. **Carefully** remove the ignitor and put to the side.
3. Remove the metal plate located below the burner.
4. Remove the screws at the front and rear of the burner, remove the burner tube and locate the air shutter adjustment screw at the end of the burner tube.
5. Flame adjustments are the same as the grill #4-#7.
6. Replace all griddle parts and griddle.

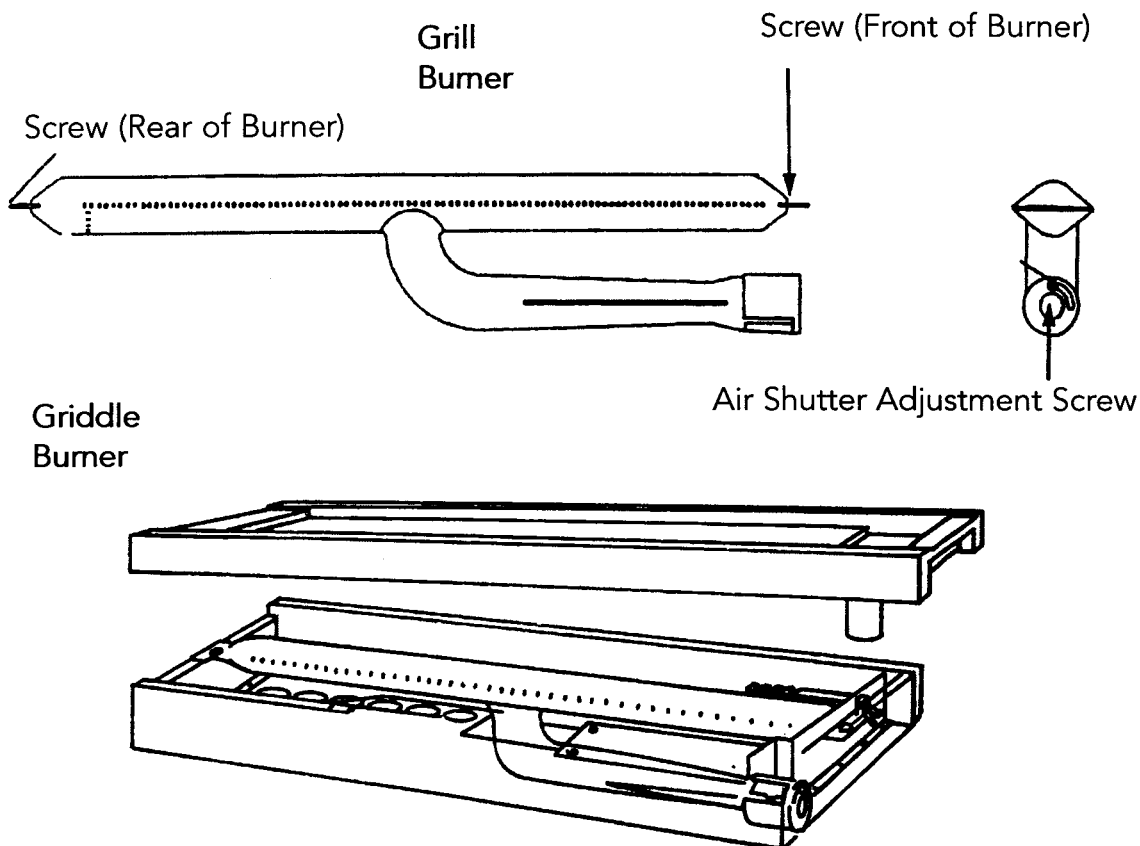

INITIAL IGNITION OF BURNERS (For Open Surface Burners)

All ranges are tested before leaving the factory. Field adjustments may be necessary for proper mixture of gas and air for proper operation. When the range is connected to gas and electric service, it should be adjusted by a qualified technician.

When adjustments are required, contact your dealer/installer for corrections. If assistance is not available, contact Viking Range Corporation Preferred Service for the nearest authorized service agent at (662) 451-4133. All corrections to installation are the responsibility of the dealer/installer or end user.

INITIAL IGNITION OF BURNERS (For Sealed Surface Burners)

All sealed top ranges are tested before leaving the factory. There are no adjustments for the sealed surface burners if connected according to the information on the rating plate. Check each burner for proper operations. Flames should be blue in all settings. If service is required, contact your dealer for the name of their authorized service agency. If none is available, contact Viking Preferred Service for the nearest authorized service agency in your area. Gas conversions and initial installation are not the responsibility of the manufacturer.

PERFORMANCE CHECKLIST

The installer should carry out the following performance checks. Refer to instructions below.

1. Check surface burner ignition.
2. Check air shutter adjustment - sharp blue flame, no yellow tipping, sooting or flame lifting
3. Check low flame adjustment - surface burner valve center stem adjustment.
4. Check griddle ignition - all burner ports.
5. Check grill ignition - all burner ports.
6. Visually check tubular burner reignition to be sure both sides are relighting each time.
6. Check for gas leaks (odors) at all gas connections.
7. Check oven bake and convection bake function.

FINAL PREPARATION

1. Some stainless steel parts may have a plastic protective wrap which must be removed. The interior of the oven should be washed thoroughly with hot, soapy water to remove film residues and any installation dust or debris before being used for food preparation, then rinsed and wiped dry. Solutions stronger than soap and water are rarely needed.
2. All stainless steel body parts should be wiped with hot, soapy water and with a liquid cleaner designed for this material. If buildup occurs, do not use steel wool, abrasive cloths, cleaners, or powders! If it is necessary to scrape stainless steel to remove encrusted materials, soak with hot, wet cloths to loosen the material, then use a wood or nylon scraper. Do not use a metal knife, spatula, or any other metal tool to scrape stainless steel! Scratches are almost impossible to remove.

NOTE: These installation instructions should remain with the unit for future reference. The electrical diagram is located beneath the drip tray in the rear corner of the burner box. Remove the right rear burner bowl and pull the drip tray forward approximately 6" (15.2 cm).

REPLACEMENT PARTS

Only authorized replacement parts may be used in performing service on the oven. Replacement parts are available from factory authorized parts distributors. Contact Viking Range Corporation Preferred Service, (662) 451-4133, for the nearest parts distributor in your area.

BASIC SPECIFICATIONS

Description	24" W. Models
Overall width	23 7/8" (60.6 cm)
Overall height	<p><u>Base Height</u> To top of grate support - Min. 35 7/8" (91.1 cm) to Max. 37 5/8" (95.6 cm) Legs adjust 1 3/4" (4.5 cm)</p> <p><u>Additions to Base Height</u> To top of grate - add 1 1/8" (2.9 cm) To top of island trim - add 1 1/4" (3.2 cm) To top of 6" backguard - add 6" (15.2 cm) To top of high shelf - add 23 1/2" (59.7 cm)</p>
Overall depth from rear	To end of side panel - 24 5/16" (61.8 cm) To end of control panel - 26 1/4" (66.7 cm) To end of knobs - 27 3/4" (70.5 cm)
Electrical requirements	120 VAC/60 Hz; 4 ft. (121.9 cm), 3-prong plug attached to the unit.
Gas requirements	Shipped natural gas standard; convert to LP/Propane with standard convertible regulator; accepts standard residential 1/2" ID gas service line
Maximum amp usage	4B 4.3 amps G 11.5 amps Q 4.3 amps K 4.3 amps
Surface burner rating (if applicable)	15,000 BTU Nat./13,500 BTU LP (4.4 kW/4.0 kW)
Griddle burner rating (if applicable)	Two 15,000 BTU ea. Nat./13,500 BTU ea. LP (4.4 kW/4.0 kW)
Grill burner rating (if applicable)	Two 18,000 BTU ea. Nat./16,000 BTU ea. LP (5.3 kW/4.7 kW)
Wok burner rating	27,500 BTU Nat./LP (8.1 kW)
Broil rating	15,000 BTU Nat./13,500 BTU LP (4.4 kW/4.0 kW)
Bake rating	30,000 BTU Nat./LP (8.8 kW)
Oven Interior width	18" (45.7 cm)
Oven Interior height	16 1/8" (41.0 cm)
Oven Interior depth	17 5/8" (44.8 cm)
Oven Interior overall size	3.0 cu. ft.
Approximate Shipping wt.	395 lbs. (177.8 kg)

Minimum clearances from adjacent combustible construction

- Cooking surface and below (36" [91.4 cm] and below)
 - Sides - 0"
 - Rear - 0" with backguard or high shelf; 0" with island trim and non-combustible rear wall; 6" (15.2 cm) with island trim and combustible rear wall.
 - Top grate support - 36" (91.4 cm)
- Above cooking surface (above 42" [91.4 cm])
 - Sides - Models 4B, G, K - 6" (15.2 cm); Model Q - 9" (22.9 cm)
 - Within 6" (15.2 cm) side clearance, wall cabinets no deeper than 13" (33.0 cm) must be minimum 18" (45.7 cm) above cooking surface.
 - Wall cabinets directly above product must be minimum 42" (106.7 cm) above cooking surface
- Use range only with factory supplied legs.

BASIC SPECIFICATIONS

Description	30" W. Models	36" W. Models
Overall width	29 7/8" (75.9 cm)	35 7/8" (91.1 cm)
Overall height	<u>24" Deep Models Base Height</u> <u>27" Deep Models Base Height</u> To top of grate support - Min. 35 7/8" (91.1 cm) to Min. 36 1/8" (91.8 cm) Max. 37 5/8" (95.6 cm) Max 39 1/8" (99.4 cm) Legs adjust 1 3/4" (4.5 cm) Legs adjust 3" (7.6 cm)	
Overall depth from rear	<u>Additions to Base Height</u>	
	To top of spider grate -	add 1 1/8" (2.9 cm)
	To top of island trim -	add 1 1/4" (3.2 cm)
	To top of 6" backguard -	add 6" (15.2 cm)
	To top of 10" backguard -	add 10" (25.4 cm)
Overall depth from rear	To top of high shelf -	add 23 1/2" (59.7 cm)
	<u>24" Deep Models</u> <u>27" Deep Models</u>	
	To end of side panel -	24 5/16" (61.8 cm) 27" (68.6 cm)
	To end of control panel -	26 1/4" (66.7 cm) 28 3/4" (73.0 cm)
To end of knobs -	27 3/4" (70.5 cm) 30 3/8" (77.2 cm)	
Electrical requirements	120 VAC/60 Hz; 4 ft. (121.9 cm), 3-prong plug attached to the unit.	
Gas requirements	Shipped natural gas standard; convert to LP/Propane with standard convertible regulator; accepts standard residential 1/2" ID gas service line	
Maximum amp usage/	8.2 amps	6B - 8.5 amps 4G - 11.8 amps 4Q - 8.5 amps
Surface burner rating	15,000 BTU Nat./13,500 BTU LP (4.4 kW/4.0 kW)	
Griddle burner rating	N/A	15,000 BTU Nat./12,500 BTU LP (4.4 kW /3.7 kW)
Grill burner rating	N/A	18,000 BTU Nat./16,000 BTU LP 5.3 kW (gross) / 4.7 kW (net)
Broil rating	18,000 BTU Nat./16,000 BTU LP (5.3 kW/4.7 kW)	
Bake rating	Two 15,000 BTU ea. Nat./LP (Two 4.4 kW ea.)	
Oven Interior width	24" (61.0 cm)	30 1/8" (76.5 cm)
Oven Interior height	16 1/8" (41.0 cm)	24" D. Model- 16 1/8" (41.0 cm) 27" D. Model- 14 1/8" (35.9 cm)
Oven Interior depth	17 5/8" (44.8 cm)	24" D. Model- 17 5/8" (44.8 cm) 27" D. Model- 19 1/4" (48.9 cm)
Oven Interior overall size	4.0 cu. ft.	24" D. - 5.0 cu. ft. 27" D. - 4.7 cu. ft.
Approximate Shipping wt.	395 lbs. (173.3 kg)	6B - 447 lb. (201.2 kg) 4Q - 457 lb. (205.7 kg) 4G - 452 lb. (203.4 kg)

Minimum clearances from adjacent combustible construction

- Cooking surface and below (36" [91.4 cm] and below)
 - Sides - 0"
 - Rear - 0" with backguard or high shelf; 0" with island trim and non-combustible rear wall; 6" (15.2 cm) with island trim and combustible rear wall.
 - Top grate support - 36" (91.4 cm)
- Above cooking surface (above 36" [91.4 cm])
 - Sides - 6" (15.2 cm)
 - Within 6" (15.2 cm) side clearance, wall cabinets no deeper than 13" (33.0 cm) must be minimum 18" (45.7 cm) above cooking surface.
 - Wall cabinets directly above product must be minimum 36" (91.4 cm) for open top burners and 42" (106.7 cm) for sealed burners above cooking surface
- Use range only with factory supplied legs.

BASIC SPECIFICATIONS

Description	48" W. Models	60" W. Models
Overall width	47 7/8" (121.6 cm)	59 1/2" (151.1 cm)
Overall height	<u>24" Deep Models Base Height</u> To top of grate support - Min. 35 7/8" (91.1 cm) to Max. 37 5/8" (95.6 cm) Legs adjust 1 3/4" (4.5 cm) <u>Additions to Base Height</u> To top of spider grate - add 1 1/8" (2.9 cm) To top of island trim - add 1 1/4" (3.2 cm) To top of 6" backguard - add 6" (15.2 cm) To top of 10" backguard - add 10" (25.4 cm) To top of high shelf - add 23 1/2" (59.7 cm)	<u>27" Deep Models Base Height</u> Min. 36 1/8" (91.8 cm) Max 39 1/8" (99.4 cm) Legs adjust 3" (7.6 cm)
Overall depth from rear	<u>24" Deep Models</u> To end of side panel - 24 5/16" (61.8 cm) To end of control panel - 26 1/4" (66.7 cm) To end of knobs - 27 3/4" (70.5 cm)	<u>27" Deep Models</u> 27" (68.6 cm) 28 3/4" (73.0 cm) 30 3/8" (77.2 cm)
Electrical requirements	120 VAC/60 Hz; 4 ft. (121.9 cm), 3-prong plug attached to unit	
Gas requirements	Shipped natural gas standard; field convert to LP/Propane with standard convertible regulator	
Maximum amp usage/	6G - 16.0 amps 6Q - 12.4 amps 4GQ - 16.0 amps	6G - 23.6 amps 6GQ - 20.0 amps
Surface burner rating	15,000 BTU Nat./13,500 BTU LP (4.4 kW/4.0 kW)	
Griddle burner rating	12" / 18" Wide 15,000 BTU Nat./12,500 BTU LP (4.4 kW/3.7 kW)	24" Wide Two 15,000 BTU ea. Nat./12,500 BTU ea. LP (Two 4.4 kW ea./3.7 kW ea.)
Grill burner rating	18,000 BTU Nat./16,000 BTU LP (5.3 kW/4.7 kW)	
Broil rating	18,000 BTU Nat./16,000 BTU LP (5.3 kW/4.7 kW)	
Bake rating	Right - Two 15,000 BTU ea. Nat./LP (Two 4.4 kW ea.) Left - One 15,000 BTU ea. Nat./LP (One 4.4 kW ea.)	Two 15,000 BTU ea. Nat./LP (Two 4.4 kW ea.) Two 15,000 BTU ea. Nat./LP (Two 4.4 kW ea.)
Oven Interior width	Right - 24 1/8" (61.3 cm) Left - 13 3/8" (34.0 cm)	Both - 24 1/8" (61.3 cm)
Oven Interior height	<u>24" D. Models</u> Both - 16 1/8" (41.0 cm) <u>27" D. Models</u> Both - 14 1/8" (35.9 cm)	<u>27" D. Models</u> Both- 14 1/8" (35.9 cm)
Oven Interior depth	<u>24" D. Models</u> Right - 17 5/8" (44.8 cm) Left - 18 3/4" (47.6 cm) <u>27" D. Models</u> Right - 19 1/4" (48.9 cm) Left - 21 1/4" (54.0 cm)	<u>27" D. Models</u> Both - 19 1/4" (48.9 cm)
Oven Interior overall size	<u>24" D. Models</u> Right - 4.0 cu. ft. Left - 2.3 cu. ft. <u>27" D. Models</u> Right - 3.8 cu. ft. Left - 2.3 cu. ft.	<u>27" D. Models</u> Both - 3.8 cu. ft.
Approximate Shipping wt. 6G -	591 lb. (266.0 kg) 6Q - 586 lb. (263.7 kg) 4GQ - 596 lb. (268.5 kg)	6G - 762 lb. (342.9 kg) 6GQ - 757 lb. (340.7 kg)

(For Minimum clearances from adjacent combustible construction refer to bottom of page 11)

WIRING DIAGRAM FREESTANDING GAS 24" W. CONVECTION RANGE

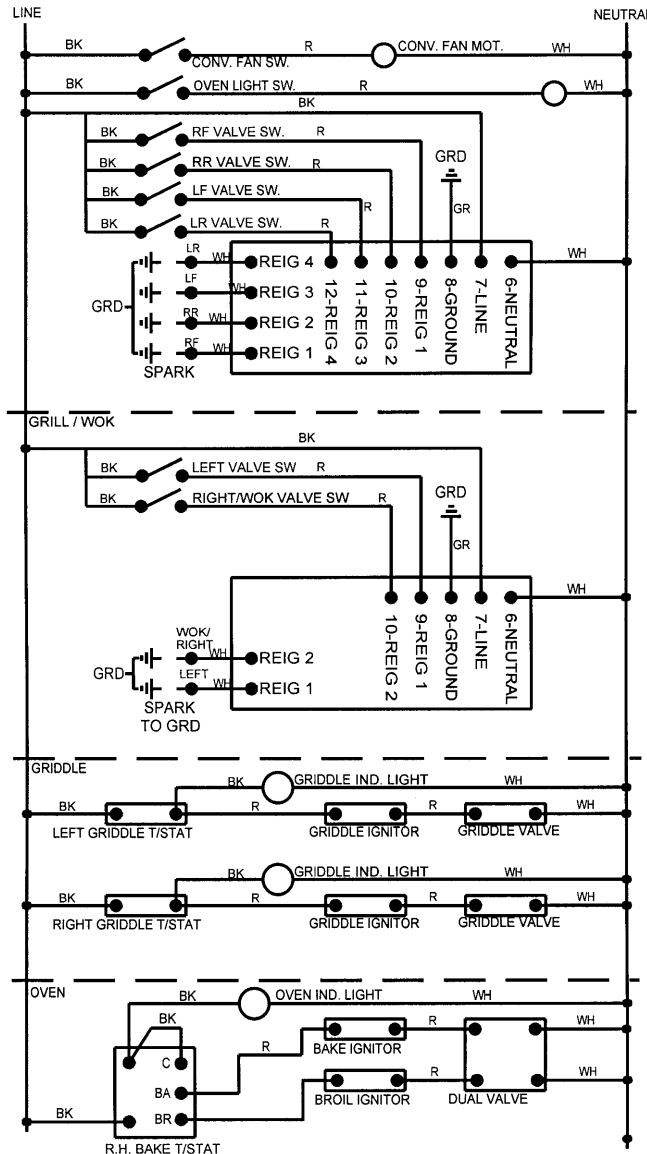

WARNING-ELECTRICAL GROUNDING INSTRUCTIONS
THIS APPLIANCE IS EQUIPPED WITH A THREE PRONG
GROUNDING PLUG FOR YOUR PROTECTION AGAINST SHOCK
HAZARD AND SHOULD BE PLUGGED DIRECTLY INTO A PROPERLY
GROUNDED THREE PRONG RECEPTACLE. DO NOT CUT OR
REMOVE THE GROUNDING PRONG FROM THIS PLUG.

CAUTION- LABEL ALL WIRES PRIOR TO DISCONNECTION WHEN
SERVICING CONTROLS. WIRING ERRORS CAN CAUSE
IMPROPER AND DANGEROUS OPERATION.
VERIFY PROPER OPERATION AFTER SERVICING.

REFER ONLY TO FEATURES WHICH ARE
EQUIPPED WITH THIS UNIT.

WIRING DIAGRAM FREESTANDING GAS 30" W. CONVECTION RANGES

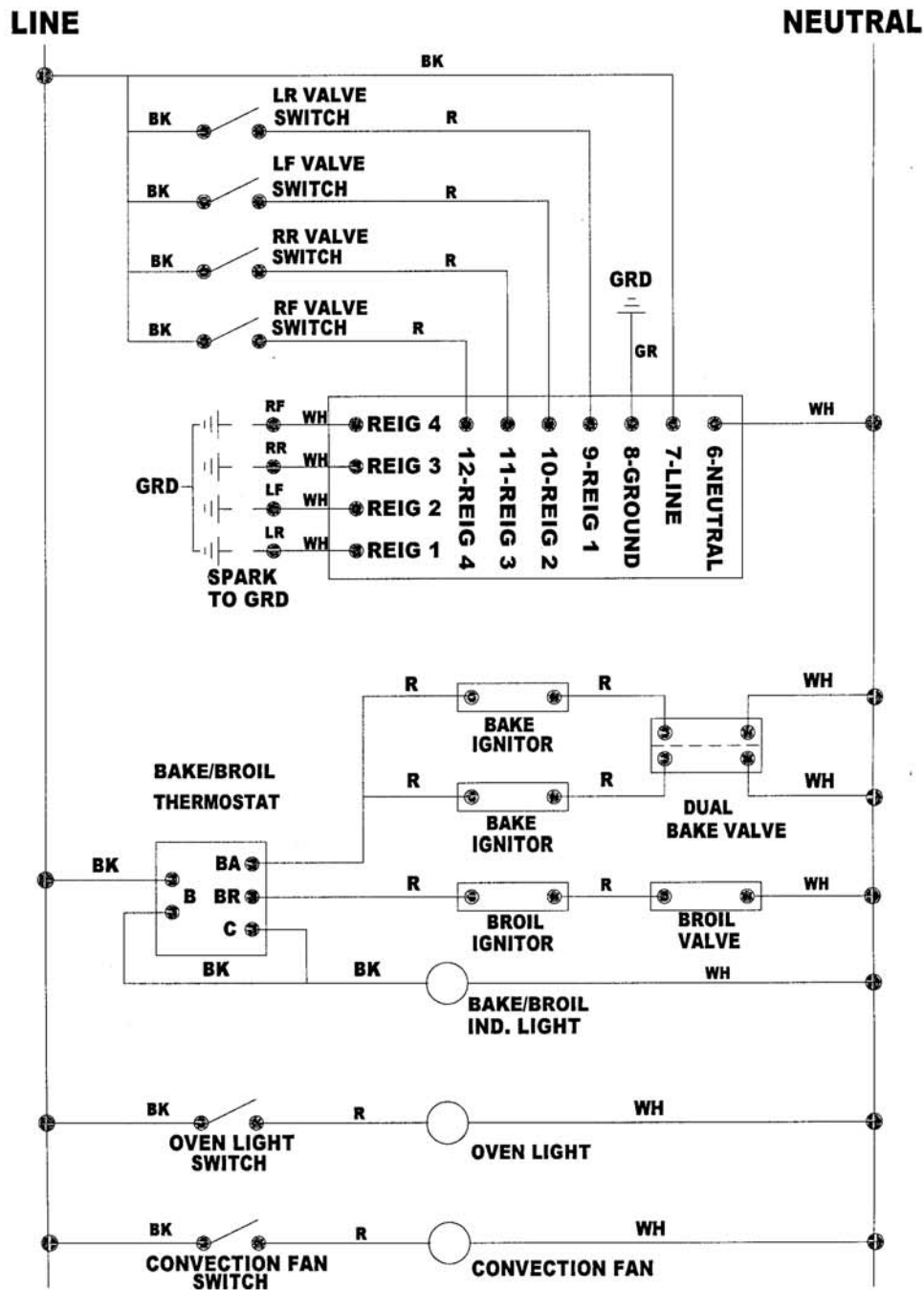

WARNING-ELECTRICAL GROUNDING INSTRUCTIONS
 THIS APPLIANCE IS EQUIPPED WITH A THREE PRONG
 GROUNDING PLUG FOR YOUR PROTECTION AGAINST SHOCK
 HAZARD AND SHOULD BE PLUGGED DIRECTLY INTO A PROPERLY
 GROUNDED THREE PRONG RECEPTACLE. DO NOT CUT OR
 REMOVE THE GROUNDING PRONG FROM THIS PLUG.

CAUTION- LABEL ALL WIRES PRIOR TO DISCONNECTION WHEN
 SERVICING CONTROLS. WIRING ERRORS CAN CAUSE
 IMPROPER AND DANGEROUS OPERATION.
 VERIFY PROPER OPERATION AFTER SERVICING.

WIRING DIAGRAM FREESTANDING GAS 36"/48"/60" W. CONVECTION RANGES

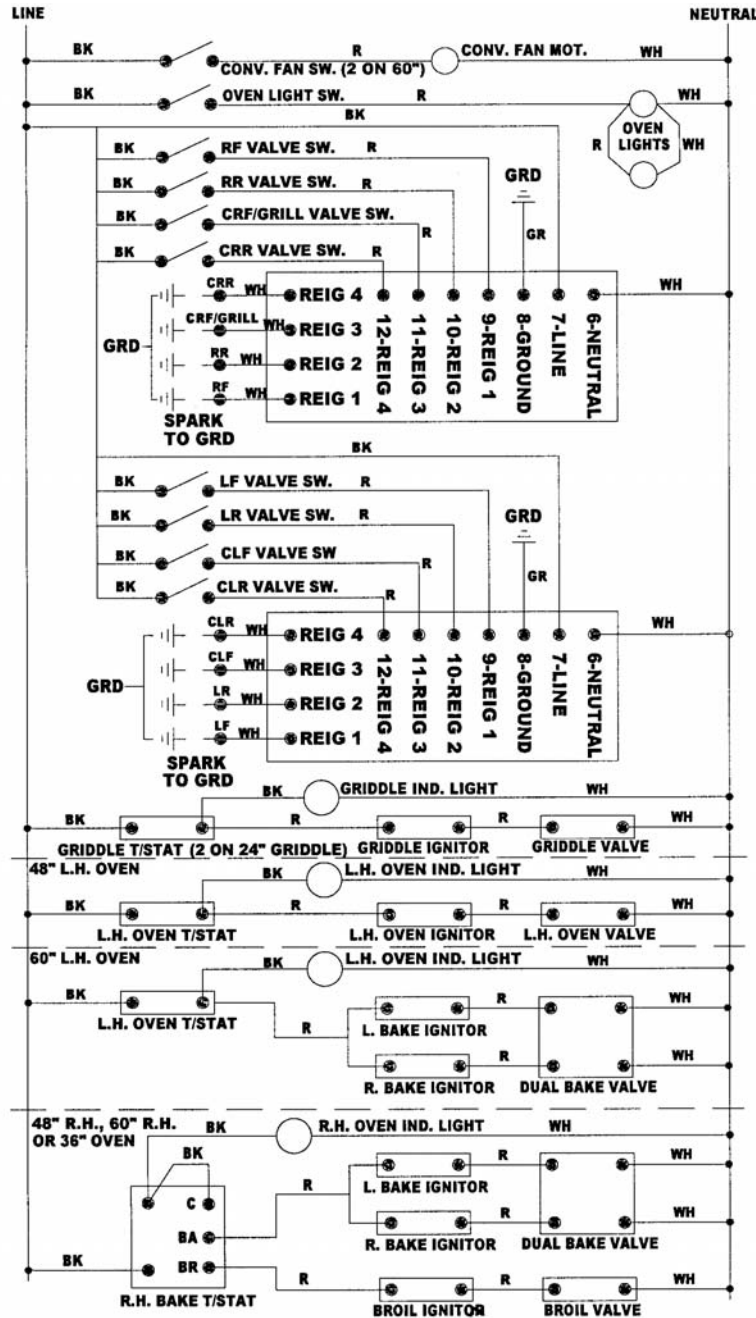

WARNING-ELECTRICAL GROUNDING INSTRUCTIONS
THIS APPLIANCE IS EQUIPPED WITH A THREE PRONG
GROUNDING PLUG FOR YOUR PROTECTION AGAINST SHOCK
HAZARD AND SHOULD BE PLUGGED DIRECTLY INTO A PROPERLY
GROUNDED THREE PRONG RECEPTACLE. DO NOT CUT OR
REMOVE THE GROUNDING PRONG FROM THIS PLUG.

CAUTION- LABEL ALL WIRES PRIOR TO DISCONNECTION WHEN
SERVICING CONTROLS. WIRING ERRORS CAN CAUSE
IMPROPER AND DANGEROUS OPERATION.
VERIFY PROPER OPERATION AFTER SERVICING.

**REFER ONLY TO FEATURES WHICH ARE
EQUIPPED WITH THIS UNIT.**

VIKING RANGE CORPORATION

111 Front Street • Greenwood, Mississippi (MS) 38930 USA • (662) 455-1200

Specifications subject to change without notice

For more product information, call 1-888-VIKING1 (845-4641), or visit our web site at <http://www.vikingrange.com>

F20254B

(PS0803VR)