

# Custom Door Panel Dimensions Scotsman DC33, DCE33, Companion Refrigerator

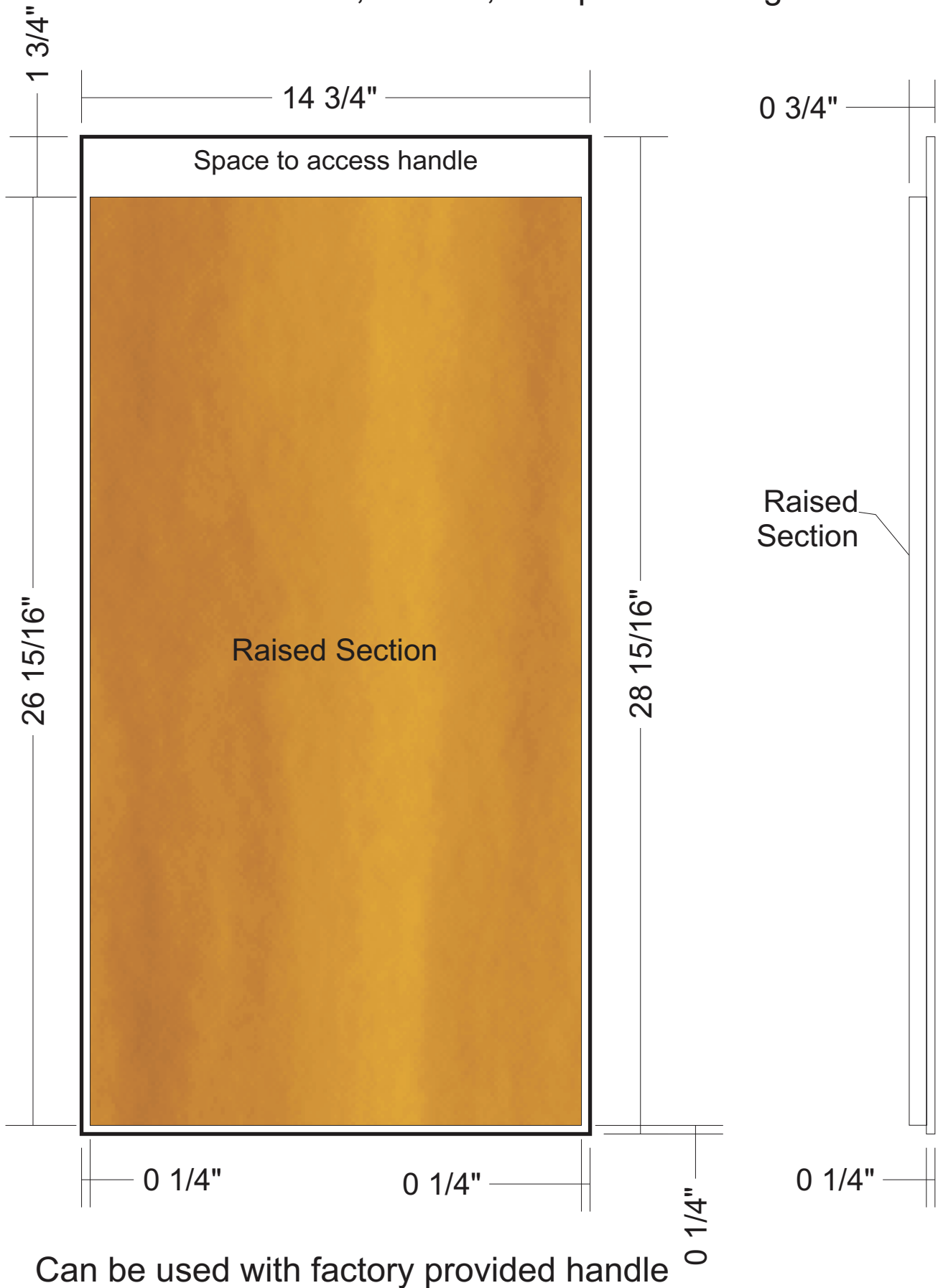

## Scotsman Custom Overlay Panel Spec

Use to make a drop in door panel that covers the door and the front of its aluminum edge. Add the KHAND to cover the top edge and a cabinet pull that matches the pulls at the installation to better blend in with the existing cabinetry.

Cut the filler panel to the dimensions shown. Apply the edge detail to the bottom, left and right sides.

The following directions are for a 3/4" x 15"w x 29"h panel door blank:

1. From the back side of the door cut a 1/16"w x 11/32" h rabbet on both sides and the bottom edge of the panel.
2. Set the saw blade to 1/4" height and cut groove in the edge of the door 7/32 from the back of the door.
3. On the hinge side of the door cut a 45 degree chamfer on the top with either a saw or a router.

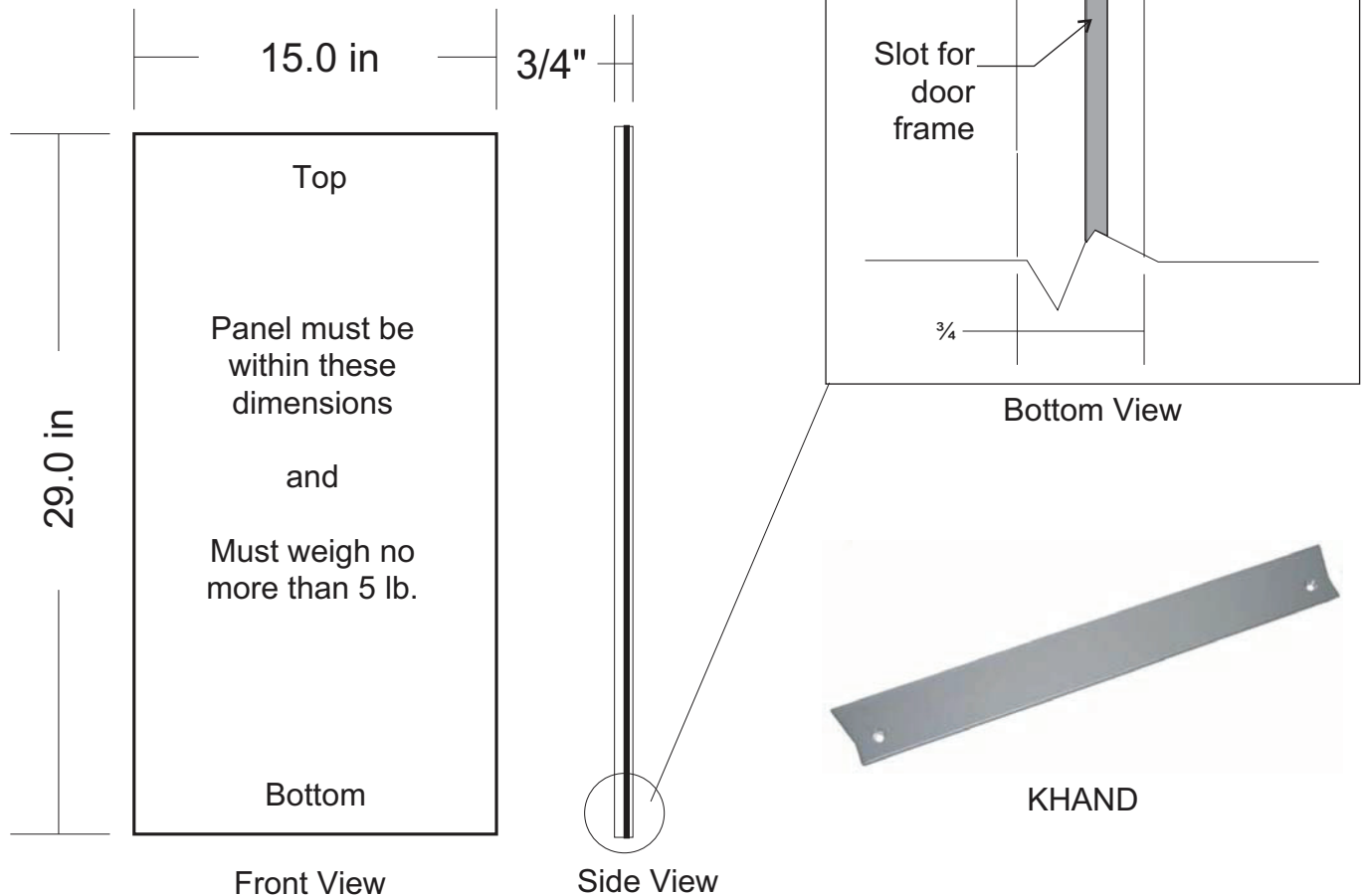

**Custom Cabinet Door Insert for Models DCE33 or Companion Refrigerator (Black or White Only)**