



3.0
CUSTOM WOOD FRAME
DESIGNER DOOR
INSTALLATION INSTRUCTIONS

READ BEFORE INSTALLATION

CUSTOM WOOD FRAME INSTALLATION INSTRUCTIONS

STEP 1: WOOD SCREWS REQUIRED

1. A #8 PAN HEAD WOOD SCREW SHOULD BE USED TO PROPERLY SECURE THE WOOD FRAME. A TOTAL OF 8 SCREWS WILL BE NEEDED. FOR A 3 1/2 INCH TOE KICK OR 7 SCREWS FOR A 4 INCH TOE KICK.
2. ONLY USE PAN HEAD SCREWS.
3. DO NOT SELECT A SCREW THAT IS LONGER THAN THE WOOD THICKNESS AT THE SCREW LOCATIONS.
4. USE RECOMMENDED PILOT HOLES FOR THE FRAME MATERIAL (SEE CHART BELOW)

PILOT HOLE DRILL SIZES FOR WOOD SCREW

WORK MATERIAL	WOOD SCREW SIZE
	8
HARDWOOD	3/32
SOFTWOOD	5/64

STEP 2: ASSEMBLING DOOR HINGE BRACKETS

DISREGARD IF HINGES ARE ALREADY ATTACHED.

1. ATTACH THE TOP AND BOTTOM DOOR HINGES TO THE DOOR WITH THE 10-32 MACHINE SCREWS AND A 1/8 INCH ALLEN HEAD DRIVER AS SHOWN IN THE FIGURE BELOW.
2. PRESS IN THE SHOULDER BUSHINGS TO THE TOP AND BOTTOM DOOR HINGES. MAKE CERTAIN THAT THE SHOULDER IS TO THE OUTSIDE OF THE DOOR AS SHOWN IN THE FIGURE BELOW.
3. TEST FIT THE DOOR TO THE UNIT TO MAKE CERTAIN DOOR WILL HANG CORRECTLY. THE DOOR IS HUNG CORRECTLY WHEN THE TOP OF THE DOOR IS PARALLEL TO THE TOP OF THE UNIT. ADJUSTMENTS CAN BE MADE BY LOOSING THE DOOR HINGE MACHINE SCREWS AND MOVING THE DOOR HINGE ON THE DOOR.
4. TIGHTEN ALL FOUR MACHINE SCREWS AFTER ADJUSTMENTS HAVE BEEN MADE.
5. REMOVE THE DOOR FROM THE UNIT BY REMOVING THE UNITS TOP HINGE SET SCREW AND ANGLING THE DOOR OFF OF THE BOTTOM HINGE PIN.

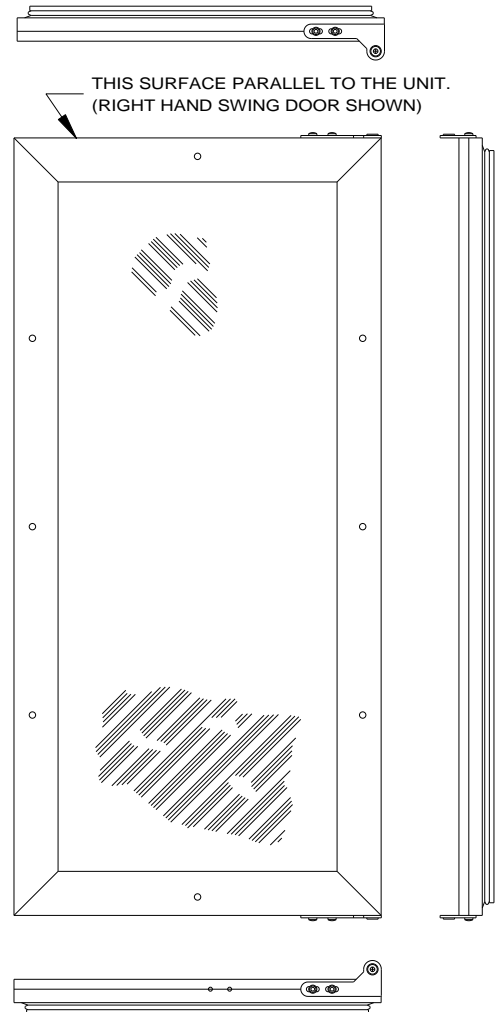
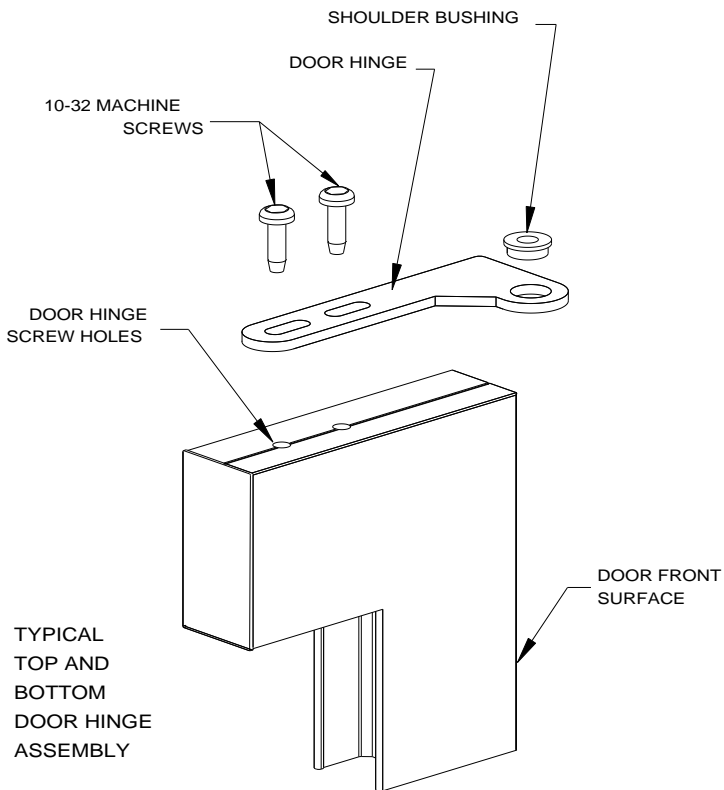

STEP 3: SELECTING AND PREPARING THE WOOD FRAME

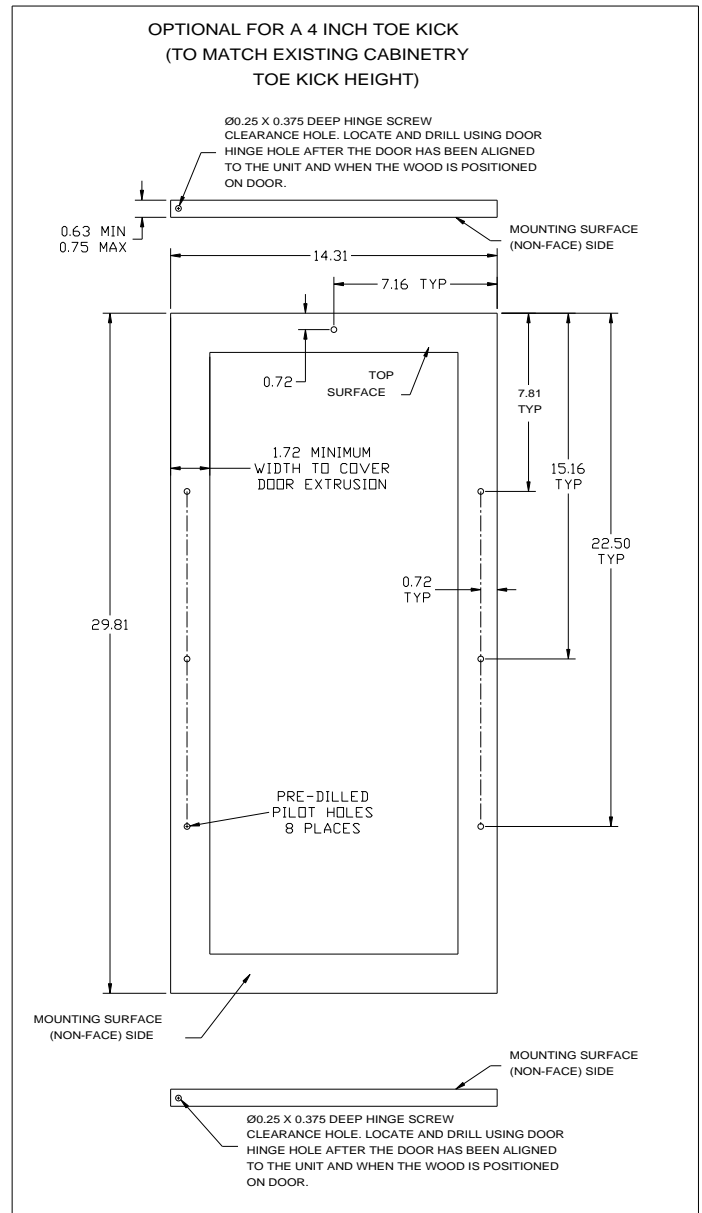
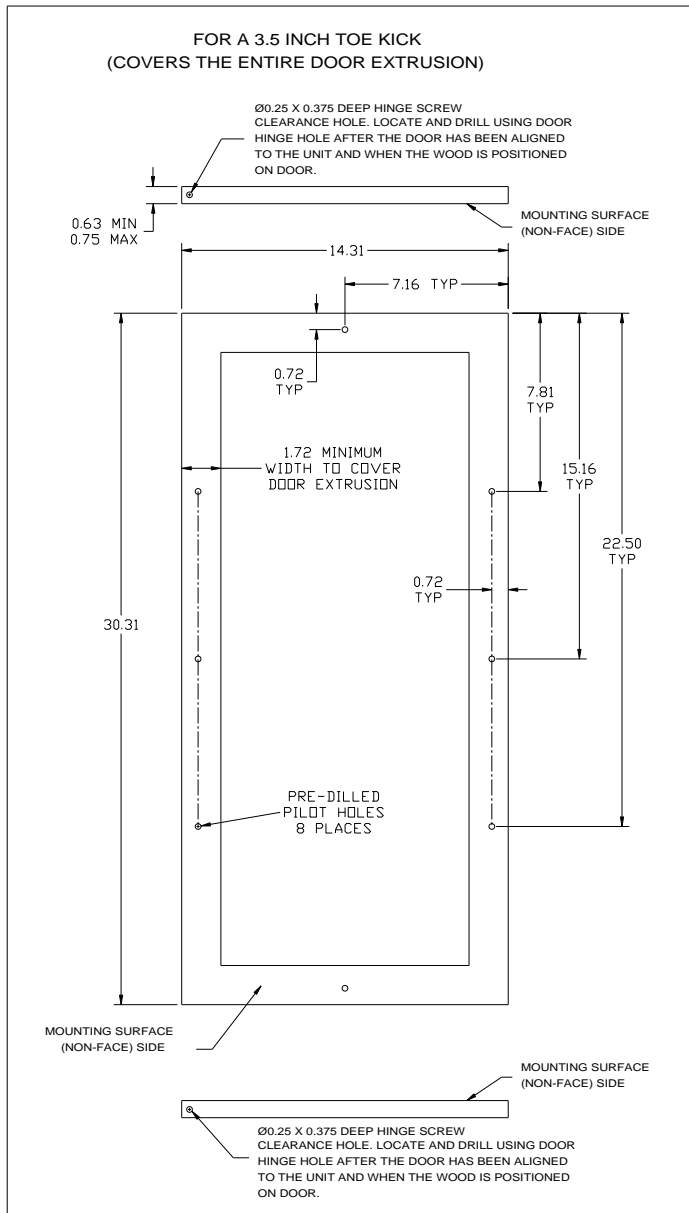

STEP 4: DETERMINING DOOR SWING

THE DOOR YOU RECEIVED IS FOR A RIGHT HAND SWING UNIT. IF THE UNIT IS TO BE CHANGED TO A LEFT HAND SWING DOOR, NEW STRIKER PLATE HOLES WILL NEED TO BE DRILLED ON THE OPPOSITE END OF THE DOOR. DO NOT DRILL NEW HOLES FOR THE HINGES ATTACHED TO THE DOOR.

THE NEW HOLE LOCATIONS ARE IN THE DRAWING BELOW. USE A 5/32" DIA. DRILL BIT BEING SURE NOT TO DRILL MORE THAN 1/4" DEEP, OTHERWISE YOU WILL DRILL INTO THE GLASS PANES. INSTALL THE SUPPLIED HOLE PLUGS IN THE OLD STRIKER PLATE HOLES THAT ARE NOW ON THE TOP OF THE DOOR.

REMOVE THE NAMEPLATE FOR THE GLASS DOOR BY GENTLY PULLING IT UP AND AWAY FROM THE GLASS SURFACE. RELOCATE THE NAMEPLATE USING THE SUPPLIED NAMEPLATE LOCATOR (P/N: 41006022).

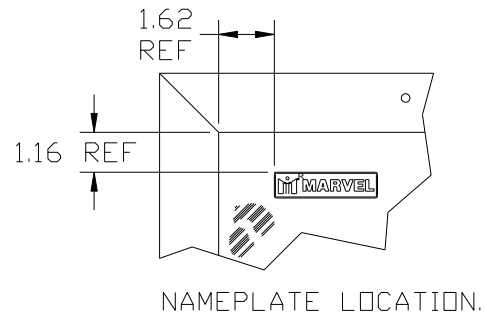

STRIKER PLATE HOLE LOCATION.

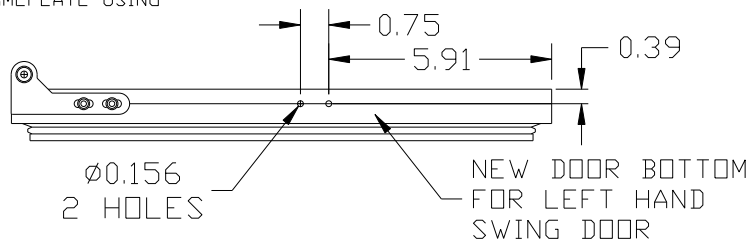

STEP 5: ATTACHING THE WOOD FRAME TO THE DOOR

1. IF THE DOOR IS ATTACHED TO THE UNIT, REMOVE IT BY UNSCREWING THE TOP ALLEN HEAD SET SCREW AT THE TOP HINGE. REMOVE THE DOOR BY ANGLING THE DOOR OFF OF THE BOTTOM HINGE PIN.
2. PEEL BACK DOOR GASKET TO EXPOSE THE SCREW HOLES.
3. SET THE WOOD FRAME FLUSH TO THE FRONT OF THE DOOR IN THE DESIRED LOCATION. CLAMP WOOD FRAME TO THE DOOR IF NECESSARY.
4. INSERT THE WOOD SCREWS THROUGH THE BACK OF THE DOOR INTO THE PILOT HOLES IN THE WOOD FRAME AND TIGHTEN.
5. REINSTALL DOOR GASKET BY PRESSING INTO DOOR CHANNEL. MAKE CERTAIN THE CORNERS ARE INSERTED FULLY.
6. INSTALL THE DOOR TO THE UNIT. USE THE SUPPLIED PLASTIC WASHERS AS SHOWN IN THE FIGURE BELOW.
7. REALIGNING THE DOOR MAY BE NECESSARY. ANY FINAL DOOR ADJUSTMENTS CAN BE MADE USING A 1/8 INCH ALLEN HEAD DRIVER TO ADJUST THE DOOR'S HINGES (SEE FIGURE BELOW).
8. ATTACH THE DOOR LIGHT STRIKER PLATE AS SHOWN USING THE HEX OR PHILLIPS HEAD SCREWS PROVIDED. MAKE CERTAIN THE LIGHT IS ABLE TO TURN ON AND OFF WHEN THE DOOR IS OPENED AND CLOSED.
9. ATTACH THE DOOR TO THE UNIT BY REVERSING STEP NUMBER 1 ABOVE.

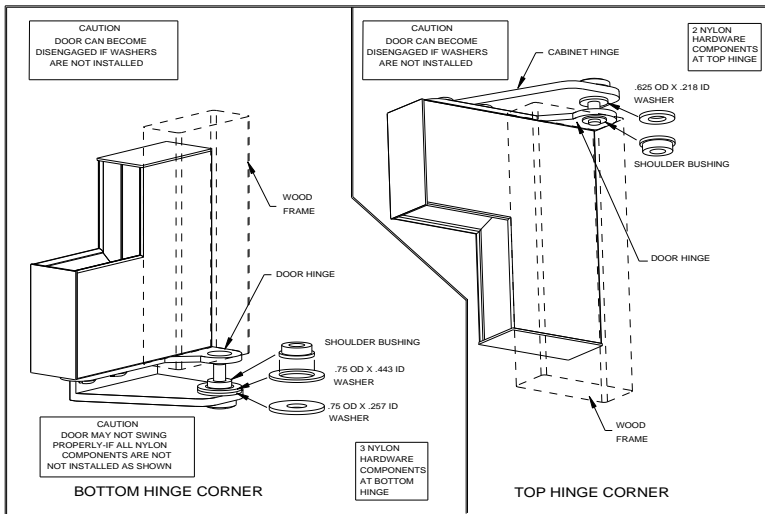

**HINGE HARDWARE
INSTALLATION DETAILS.**

