



## INSTALLATION INSTRUCTIONS FOR PART 99-3108

### APPLICATIONS

# Saturn Ion 2003-2005, LS 2000-2005 SL 2000-2002, Vue 2002-2005 99-3108

### KIT FEATURES

- ISO DIN head unit provision with pocket
- Double DIN head unit provision with pocket



### KIT COMPONENTS

- A) Radio housing • B) Radio housing brackets • C) Pocket • D) (4) #8 x 3/8" Phillips screws

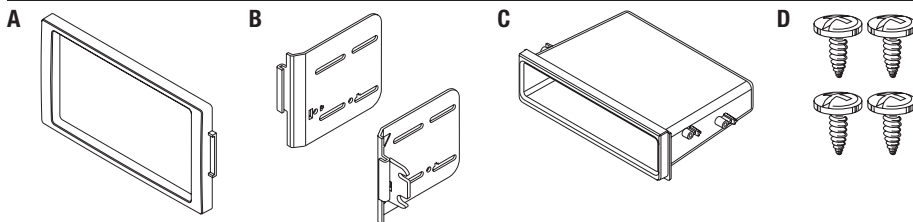

### TOOLS REQUIRED

- Flat blade screwdriver • Phillips screwdriver • Socket wrench

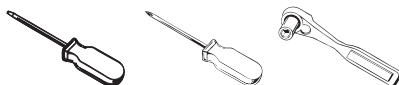

**METRA. THE WORLD'S BEST KITS.™**



**1-800-221-0932**



**metraonline.com**

© COPYRIGHT 2004-2011 METRA ELECTRONICS CORPORATION

REV. 9/7/11



99-3108

## Table of Contents

### Dash Disassembly

– Saturn Ion 2003-2005 .....	3
– Saturn LS 200-2005 .....	3
– Saturn SL 2000-2002 .....	4
– Saturn Vue 2002-2005 .....	5

### Kit Assembly

– ISO DIN head unit provision with pocket .....	6
– Double DIN head unit provision .....	7

***CAUTION: Metra recommends disconnecting the negative battery terminal before beginning any installation. All accessories, switches, and especially air bag indicator lights must be plugged in before reconnecting the battery or cycling the ignition.***

***Note: Refer to the instructions included with the aftermarket radio.***



#### KNOWLEDGE IS POWER

Enhance your installation and fabrication skills by enrolling in the most recognized and respected mobile electronics school in our industry. Log onto [www.installerinstitute.com](http://www.installerinstitute.com) or call 800-354-6782 for more information and take steps toward a better tomorrow.



**Metra recommends MECP  
certified technicians**



## Dash Disassembly 99-3108

### Saturn Ion 2003-2005

1. Unclip and remove the trim panel surrounding the radio. (Figure A)
2. Remove (2) 9/32" screws from radio to remove. (Figure A)

*Continue to kit assembly*

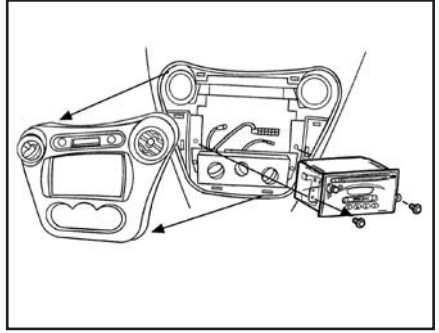

(Figure A)

### Saturn LS 2000-2005

1. Unclip and remove the trim panel surrounding the radio. (Figure A)
2. Remove (2) 9/32" screws from radio to remove. (Figure A)

*Continue to kit assembly*

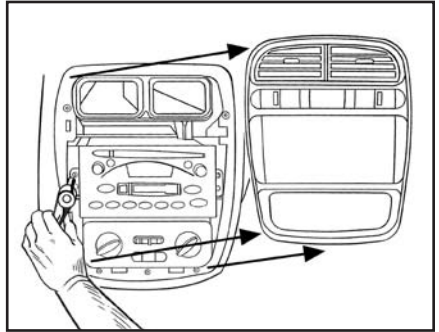

(Figure A)



## Dash Disassembly 99-3108

### Saturn SL 2000-2002

1. Remove (4) Phillips from panel below steering column and unclip and remove. (Figure A)
2. Remove (4) Phillips screws from the steering column trim panel and remove. (Figure B)
3. Remove (2) screws from the end cap/vent on the left side of the steering column then unclip and remove. (Figure C)
4. Unclip and remove the entire dash panel surrounding the radio, instrument cluster and a/c controls. (Figure D)
5. Remove (2) 9/32" screws securing the head unit to remove. (Figure D)

*Continue to kit assembly*

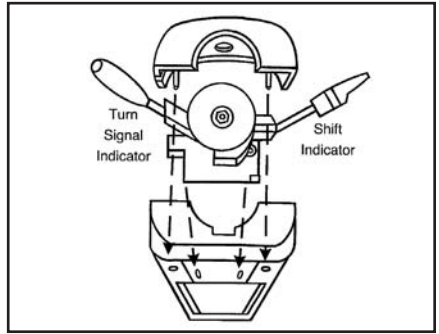

(Figure B)

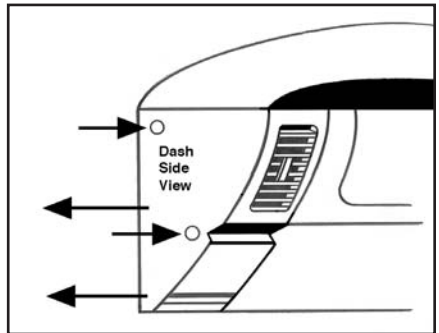

(Figure C)

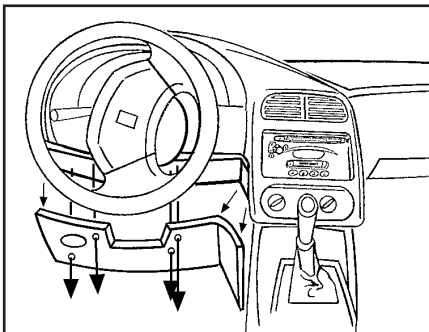

(Figure A)

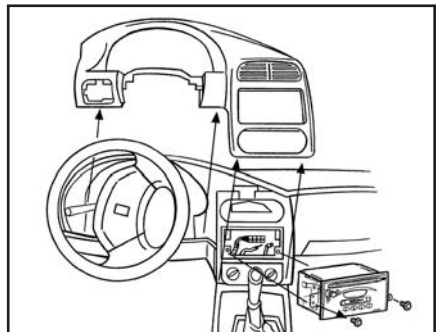

(Figure D)



## Dash Disassembly 99-3108

### Saturn Vue 2002-2005

1. Unsnap and remove shifter trim panel. (Figure A)
2. Remove (4) 9/32" screws from the dash pocket and remove. (Figure A)
3. Unsnap and remove panel surrounding radio and a/c controls. (Figure A)
4. Remove (2) 9/32" screws from radio to remove. (Figure A)

*Continue to kit assembly*

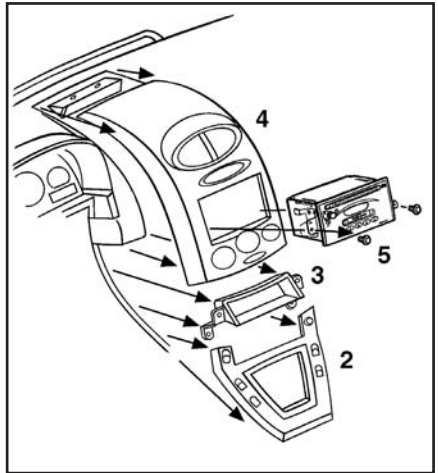

(Figure A)



## Kit Assembly 99-3108

### ISO DIN head unit provision with pocket

1. Slide the radio housing brackets onto the sides of the radio housing. (Figure A)
2. Mount the pocket to the brackets with the supplied (4) screws. (Figure B)
3. Mount the radio to the brackets with the screws supplied with the unit. (Figure B)
4. Locate the factory wiring harness in the dash. Metra recommends using the proper mating adapter from Metra or AXCESS. Re-connect the negative battery terminal and test the unit for proper operation.
5. Reassemble dash in reverse order of disassembly.

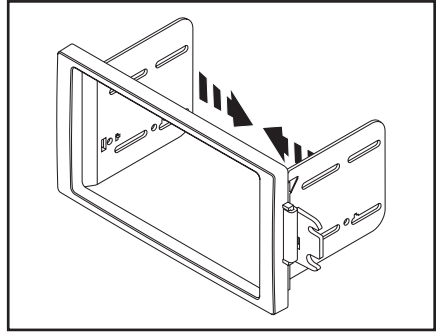

(Figure A)

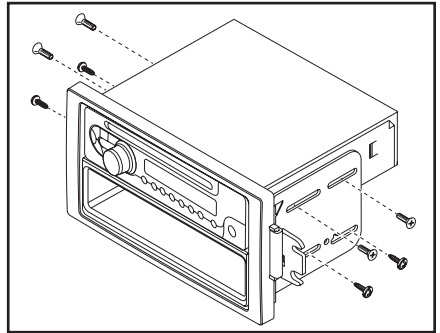

(Figure B)



## Kit Assembly 99-3108

### Double DIN head unit provision

1. Slide the radio housing brackets onto the sides of the radio housing.  
(Figure A)
2. Mount the radio to the DDIN Brackets with the screws supplied with the unit.  
(Figure B)
3. Locate the factory wiring harness in the dash. Metra recommends using the proper mating adapter from Metra or AXXESS. Re-connect the negative battery terminal and test the unit for proper operation.
4. Reassemble dash in reverse order of disassembly.

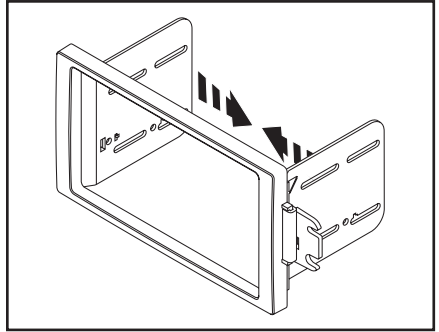

(Figure A)

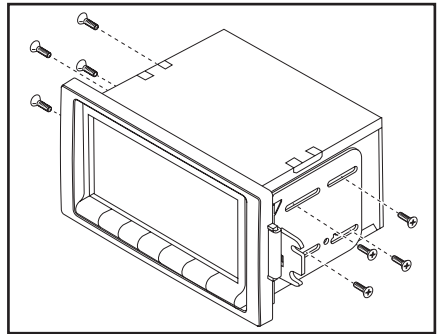

(Figure B)



**INSTALLATION INSTRUCTIONS FOR PART 99-3108**

REV. 9/7/11

**METRA. THE WORLD'S BEST KITS.™**



**1-800-221-0932**



**metraonline.com**

© COPYRIGHT 2004-2011 METRA ELECTRONICS CORPORATION





## INSTRUCCIONES DE INSTALACIÓN PARA LA PIEZA 99-3108

### APLICACIONES

# Saturn Ion 2003-2005, LS 2000-2005 SL 2000-2002, Vue 2002-2005 99-3108

### CARACTERÍSTICAS DEL KIT

- Provisión de unidad central DIN ISO con bolsillo
- Provisión de unidad central doble DIN



### COMPONENTES DEL KIT

- A) Alojamiento del radio • B) Soportes de carcasa del radio • C) Bolsillo
- D) (4) Tornillos Phillips de cabeza segmentada #8 x 3/8"

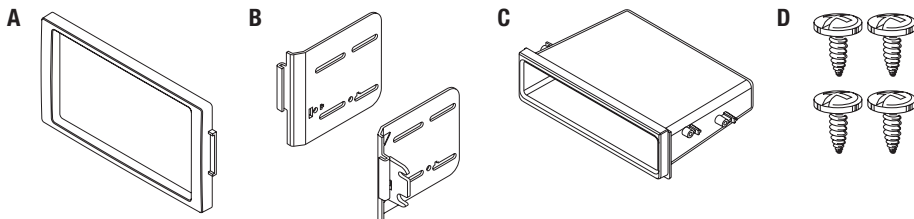

### HERRAMIENTAS REQUERIDAS

- Destornillador de hoja plana • Destornillador Phillips • Llave de tubo

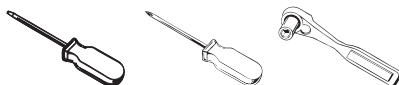

**METRA. THE WORLD'S BEST KITS.™**



**1-800-221-0932**



**metraonline.com**

© COPYRIGHT 2004-2011 METRA ELECTRONICS CORPORATION

REV. 3/8/12



99-3108

## Indice

### Dash Disassembly

– Saturn Ion 2003-2005 .....	3
– Saturn LS 200-2005 .....	3
– Saturn SL 2000-2002 .....	4
– Saturn Vue 2002-2005 .....	5

### Kit Assembly

– Provisión de unidad central ISO DIN con bolsillo .....	6
– Provisión de unidad central doble DIN .....	7

**PRECAUCIÓN:** *Metra recomienda desconectar el terminal negativo de la batería antes de comenzar cualquier instalación. Todos los accesorios, interruptores y, especialmente, las luces indicadoras de airbag deben estar enchufados antes de volver a conectar la batería o comenzar el ciclo de ignición.*

**Nota:** *Remítase a las instrucciones incluidas con el radio de posventa.*



#### EL CONOCIMIENTO ES PODER

Mejore sus habilidades de instalación y fabricación inscribiéndose en la escuela de dispositivos electrónicos móviles más reconocida y respetada de nuestra industria. Regístrese en [www.installerinstitute.com](http://www.installerinstitute.com) o llame al 800-354-6782 para obtener más información y avance hacia un futuro mejor.



**Metra recomienda técnicos con certificación del Programa de Certificación en Electrónica Móvil (Mobile Electronics Certification Program, MECP).**

### Saturn Ion 2003-2005

1. Desenganche y retire el panel de moldura que rodea el radio. (Figura A)
2. Retire los (2) tornillos de 9/32" del radio y retire. (Figura A)

*Continue to kit assembly*

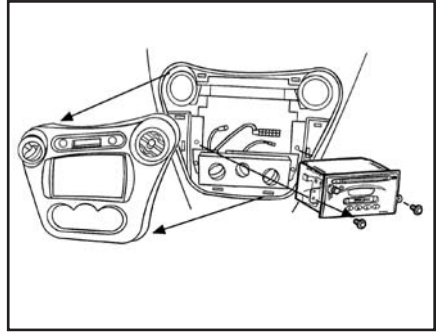

(Figura A)

### Saturn LS 2000-2005

1. Desenganche y retire el panel de moldura que rodea el radio. (Figura A)
2. Retire los (2) tornillos de 9/32" del radio y retire. (Figura A)

*Continue to kit assembly*

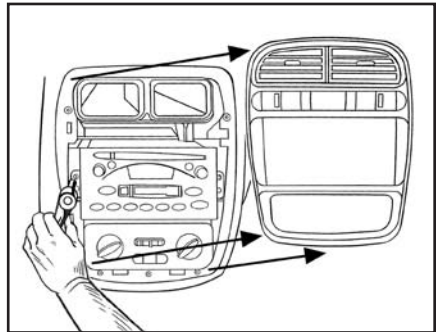

(Figura A)

## Saturn SL 2000-2002

1. Quite los (4) tornillos Phillips del panel debajo de la columna de dirección y desenganche y quítelo. (Figura A)
2. Quite los (4) tornillos Phillips del panel de la moldura de la columna de dirección y quítela. (Figura B)
3. Quite los (2) tornillos de la tapa/rejilla del lado izquierdo de la columna de dirección y luego desenganche y retire. (Figura C)
4. Desenganche y retire todo el panel del tablero que rodea el radio, el conjunto de instrumentos y los controles del aire acondicionado. (Figura D)
5. Quite los (2) tornillos de 9/32" que sujetan la unidad central para retirarla. (Figura D)

*Continue to kit assembly*

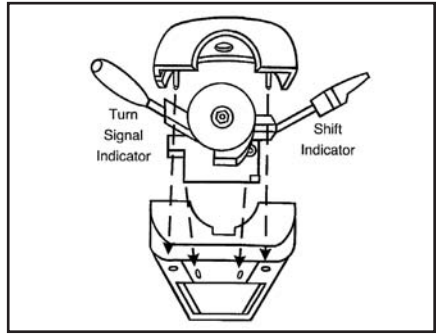

(Figura B)

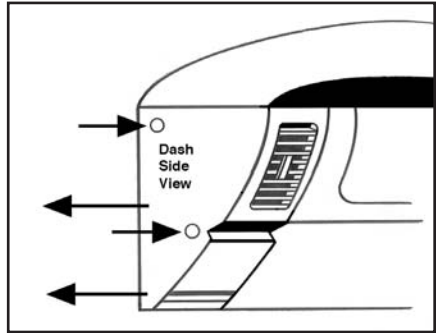

(Figura C)

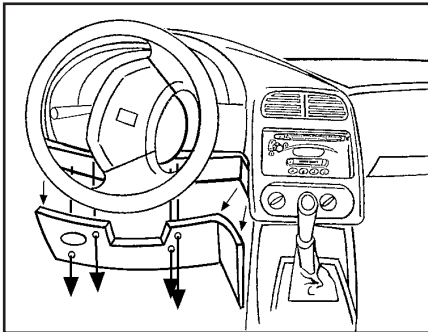

(Figura A)

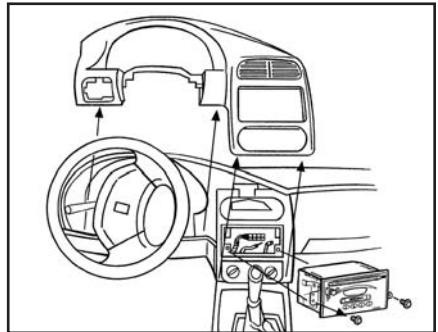

(Figura D)

## Saturn Vue 2002-2005

1. Suelte a presión y quite el panel de moldura de la palanca de velocidades. (Figura A)
2. Quite los (4) tornillos de 9/32" del bolsillo del tablero y retire. (Figura A)
3. Desenganche y quite el panel que rodea el radio y los controles del aire acondicionado. (Figura A)
4. Quite los (2) tornillos de 9/32" del radio para quitarlo. (Figura A)

*Continue to kit assembly*

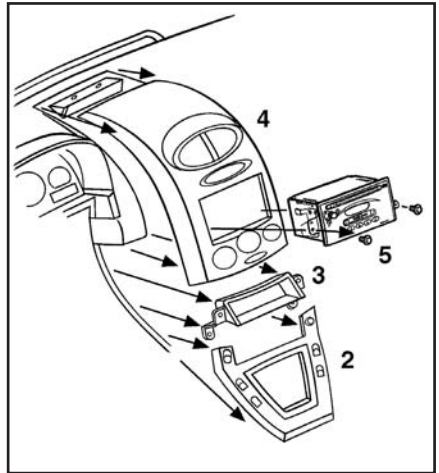

(Figura A)

### Provisión de unidad central ISO DIN con bolsillo

1. Deslice los soportes de carcasa del radio sobre los lados de la carcasa del radio. (Figura A)
2. Monte el bolsillo en los soportes con los (4) tornillos suministrados. (Figura B)
3. Monte el radio en los soportes con los tornillos suministrados con la unidad. (Figura B)
4. Ubique el arnés del cableado de fábrica en el tablero. Metra recomienda usar el adaptador de acoplamiento adecuado de Metra o AXCESS. Vuelva a conectar el terminal negativo de la batería y pruebe la unidad para verificar que funcione correctamente.
5. Vuelva a montar el tablero en forma inversa al desmontaje.

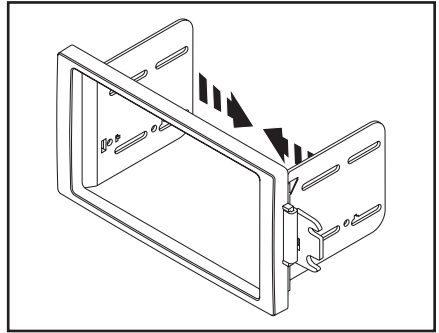

(Figura A)

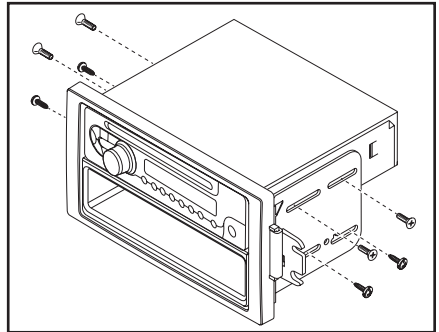

(Figura B)

### Provisión de unidad central doble DIN

1. Deslice los soportes de carcasa del radio sobre los lados de la carcasa del radio. (Figura A)
2. Monte el radio en los soportes DDIN con los tornillos que vienen con la unidad. (Figura B)
3. Ubique el arnés del cableado de fábrica en el tablero. Metra recomienda usar el adaptador de acoplamiento adecuado de Metra o AXCESS. Vuelva a conectar el terminal negativo de la batería y pruebe la unidad para verificar que funcione correctamente.
4. Vuelva a montar el tablero en forma inversa al desmontaje.

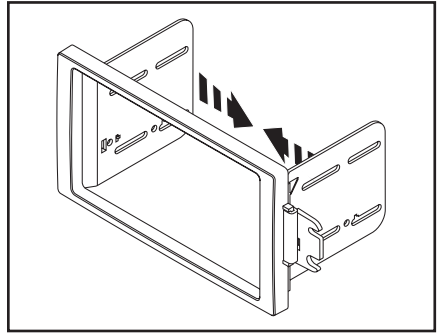

(Figura A)

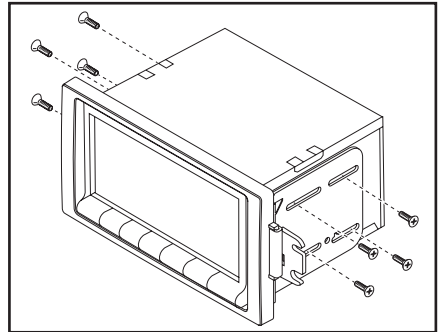

(Figura B)



**INSTRUCCIONES DE INSTALACIÓN PARA LA PIEZA 99-3108**

REV. 3/8/12

**METRA. THE WORLD'S BEST KITS.™**



**1-800-221-0932**



**metraonline.com**

© COPYRIGHT 2004-2011 METRA ELECTRONICS CORPORATION