



GENERAC® GUARDIAN® SERIES STANDBY GENERATORS

8 kW - 10 kW - 14 kW

Air-Cooled Gas Engine Generator Sets

INCLUDES:

- True Power® Electrical Technology
- Two Line LCD Tri-lingual Digital Nexus™ Controller
- Electronic Governor
- External Main Circuit Breaker & System Status LED Indicators
- Sound Attenuated Enclosure
- Flexible Fuel Line Connector
- Composite Mounting Pad
- Natural Gas or LP Gas Operation
- 3 Year Limited Warranty
- UL 2200 Listed

Standby Power Rating

- Model 005882-1 (Steel - Bisque) - 8 kW 60Hz
- Model 005883-1 (Steel - Bisque) - 10 kW 60Hz
- Model 005884-1 (Steel - Bisque) - 14 kW 60Hz



FEATURES

- **INNOVATIVE DESIGN & PROTOTYPE TESTING** are key components of GENERAC'S success in "IMPROVING POWER BY DESIGN." But it doesn't stop there. Total commitment to component testing, reliability testing, environmental testing, destruction and life testing, plus testing to applicable CSA, NEMA, EGSA, and other standards, allows you to choose GENERAC POWER SYSTEMS with the confidence that these systems will provide superior performance.
- **TRUE POWER® ELECTRICAL TECHNOLOGY:** Superior harmonics and sine wave form produce less than 5% Total Harmonic Distortion for utility quality power. This allows confident operation of sensitive electronic equipment and micro-chip based appliances, such as variable speed HVAC.
- **TEST CRITERIA:**
 - ✓ **PROTOTYPE TESTED**
 - ✓ **SYSTEM TORSIONAL TESTED**
 - ✓ **NEMA MG1-22 EVALUATION**
 - ✓ **MOTOR STARTING ABILITY**
- **SOLID-STATE, FREQUENCY COMPENSATED VOLTAGE REGULATION.** This state-of-the-art power maximizing regulation system is standard on all Generac models. It provides optimized FAST RESPONSE to changing load conditions and MAXIMUM MOTOR STARTING CAPABILITY by electronically torque-matching the surge loads to the engine. An unequalled ±1% voltage regulation.
- **SINGLE SOURCE SERVICE RESPONSE** from Generac's extensive dealer network provides parts and service know-how for the entire unit, from the engine to the smallest electronic component.
- **GENERAC TRANSFER SWITCHES.** Long life and reliability are synonymous with GENERAC POWER SYSTEMS. One reason for this confidence is that the GENERAC product line includes its own transfer systems and controls for total system compatibility.



FEATURES

Generac® Guardian® Series Standby Generator - 8 kW - 10 kW - 14 kW

ENGINE	<ul style="list-style-type: none"> •Generac (OHVI) Design •"Spiny-lok" cast iron cylinder walls •Electronic ignition/spark advance •Full pressure lubrication system •Low oil pressure shutdown system •High temperature shutdown 	<p>Maximizes engine "breathing" for increased fuel efficiency. Plateau honed cylinder walls and plasma moly rings help engine run cooler, reducing oil consumption. Because heat is the primary cause of engine wear, the OHVI has a significantly longer life than competitive engines.</p> <p>Rigid construction and added durability provide long engine life.</p> <p>These features combine to assure smooth, quick starting every time.</p> <p>Superior lubrication to all vital bearings means better performance, less maintenance and significantly longer engine life. Now featuring a 2 year/200 hour oil change interval.</p> <p>Superior shutdown protection prevents catastrophic engine damage due to low oil.</p> <p>Prevents damage due to overheating.</p>
GENERATOR	<ul style="list-style-type: none"> •Revolving field •Skewed rotor (8 & 10 kW) Skewed stator (14 kW) •Displaced phase excitation •Automatic voltage regulation •UL 2200 Listed 	<p>Allows for smaller, light weight unit that operates 25% more efficiently than a revolving armature generator.</p> <p>Produces a smooth output waveform for compatibility with electronic equipment.</p> <p>Maximizes motor starting capability.</p> <p>Regulates the output voltage to $\pm 1\%$ prevents damaging voltage spikes.</p> <p>For your safety</p>
TRANSFER SWITCH	<p>Sold separately</p>	
NEXUS™ CONTROLS	<ul style="list-style-type: none"> •Manual/Auto/Off switch •Utility voltage sensing •Generator voltage sensing •Utility interrupt delay •Engine warm-up •Engine cool-down •Programmable seven day exerciser •Smart battery charger •Main Line Circuit Breaker •Electronic governor 	<p>Selects the operating mode.</p> <p>Constantly monitors utility voltage, setpoints 60% dropout, 80% pick-up, of standard voltage.</p> <p>Constantly monitors generator voltage to ensure the cleanest power delivered to the home.</p> <p>Prevents nuisance start-ups of the engine, adjustable 10-30 seconds.</p> <p>Ensures engine is ready to assume the load, setpoint approximately 5 seconds.</p> <p>Allows engine to cool prior to shutdown, setpoint approximately 1 minute.</p> <p>Operates engine to prevent oil seal drying and damage between power outages by running the generator for 12 minutes every week.</p> <p>Delivers charge to the battery only when needed at varying rates depending on outdoor air temperature.</p> <p>Protects generator from overload.</p> <p>Maintains constant 60 Hz frequency.</p>
UNIT	<ul style="list-style-type: none"> •Weather protective enclosure •Enclosed critical grade muffler •Small, compact, attractive •SAE 	<p>Ensures protection against mother nature. Hinged key locking roof panel for security. Lift-out front for easy access to all routine maintenance items. Electrostatically applied textured epoxy paint for added durability.</p> <p>Quiet, critical grade muffler is mounted inside the unit to prevent injuries.</p> <p>Makes for an easy, eye appealing installation.</p> <p>Sound attenuated enclosure ensures quiet operation</p>
INSTALLATION SYSTEM	<ul style="list-style-type: none"> •1' Flexible Fuel Line Connector •Composite Mounting Pad 	<p>Easy Installation</p>

SPECIFICATIONS

GENERAC®

GENERATOR	Model 005882-1 (8 kW)	Model 005883-1 (10 kW)	Model 005884-1 (14 kW)
Rated Maximum Continuous Power Capacity (LP)	8,000 Watts*	10,000 Watts*	14,000 Watts*
Rated Maximum Continuous Power Capacity (NG)	7,000 Watts*	9,000 Watts*	13,000 Watts*
Rated Voltage	240	240	240
Rated Maximum Continuous Load Current – 240 Volts	33.3 LP/29.2 NG	41.6 LP/37.5 NG	58.3 LP/54.2 NG
Total Harmonic Distortion	Less than 5%	Less than 5%	Less than 5%
Main Line Circuit Breaker	35 Amp	45 Amp	60 Amp
Phase	1	1	1
Number of Rotor Poles	2	2	2
Rated AC Frequency	60Hz	60Hz	60Hz
Power Factor	1	1	1
Battery Requirement (not included)	Group 26R 12 Volts and 525 Cold-cranking Amperes Minimum	Group 26R 12 Volts and 525 Cold-cranking Amperes Minimum	Group 26R 12 Volts and 525 Cold-cranking Amperes Minimum
Unit Weight (Pounds/Kilos)	340/154.2	387/175.4	439/199.1
Dimensions (L x W x H) Inches/mm	48 x 25 x 29 (1218 x 638 x 732)		
Sound output in dB(A) at 23 ft. with generator operating at normal load	62	63	66
ENGINE	Model 005882-1 (8 kW)	Model 005883-1 (10 kW)	Model 005884-1 (14 kW)
Type of Engine	GENERAC OHVI	GENERAC OHVI V-TWIN	GENERAC OHVI V-TWIN
Number of Cylinders	1	2	2
Displacement	410cc	530cc	992cc
Cylinder Block	Aluminum w/Cast Iron Sleeve	Aluminum w/Cast Iron Sleeve	Aluminum w/Cast Iron Sleeve
Valve Arrangement	Overhead Valve	Overhead Valve	Overhead Valve
Ignition System	Solid-state w/Magneto	Solid-state w/Magneto	Solid-state w/Magneto
Governor System	Electronic	Electronic	Electronic
Compression Ratio	9.4:1	9.5:1	9.5:1
Starter	12 Vdc	12 Vdc	12 Vdc
Oil Capacity Including Filter	Approx. 1.5 Qts./1.4L	Approx. 1.7 Qts./1.6L	Approx. 1.9 Qts./1.8L
Operating RPM	3,600	3,600	3,600
Fuel Consumption			
Natural Gas	cu.ft./hr.		
	1/2 Load		
	Full Load	77	102
Liquid Propane	ft ³ /hr (gal/hr) [Liter/hr]	139	156
	1/2 Load		
	Full Load	34 (0.94) [3.56]	46 (1.25) [4.73]
		62 (1.68) [6.36]	70 (1.93) [7.31]
			58 (1.56) [5.91]
			84 (2.30) [8.71]
Required fuel pressure to generator fuel inlet at all load ranges - 5 to 7 inches of water column for natural gas, 10 to 12 inches of water column for LP gas For Btu content, multiply ft ³ /hr x 2520 (LP) or ft ³ /hr x 1000 (NG)			
CONTROLS			
2-Line Plain Text LCD Display (10 & 14 kW)	Simple user interface for ease of operation		
Mode Switch			
-Auto	Automatic Start on Utility failure. 7 day exerciser		
-Off	Stops unit. Power is removed. Control and charger still operate.		
-Manual/Test (start)	Start with starter control, unit stays on. If utility fails, transfer to load takes place.		
Programmable start delay between 10-30 seconds	Standard		
Engine Start Sequence	Cyclic cranking: 16 sec. on, 7 rest (90 sec. maximum duration)		
Engine Warm-up	5 seconds		
Engine Cool-Down	1 minute		
Starter Lock-out	Starter cannot re-engage until 5 sec. after engine has stopped.		
Smart Battery Charger	Standard		
Automatic Voltage Regulation with Over and Under Voltage Protection	Standard		
Automatic Low Oil Pressure Shutdown	Standard		
Overspeed Shutdown	Standard, 72Hz		
High Temperature Shutdown	Standard		
Overcrank Protection	Standard		
Safety Fused	Standard		
Failure to Transfer Protection	Standard		
Low Battery Protection	Standard		
50 Event Run Log	Standard		
Future Set Capable Exerciser	Standard		
Incorrect Wiring Protection	Standard		
Internal Fault Protection	Standard		
Common External Fault Capability	Standard		

Rating definitions - Standby: Applicable for supplying emergency power for the duration of the utility power outage. No overload capability is available for this rating. (All ratings in accordance with BS5514, ISO3046 and DIN6271). * Maximum wattage and current are subject to and limited by such factors as fuel Btu content, ambient temperature, altitude, engine power and condition, etc. Maximum power decreases about 3.5 percent for each 1,000 feet above sea level; and also will decrease about 1 percent for each 12° C (10° F) above 15.5° C (60° F).

AVAILABLE ACCESSORIES

Model #	Product	Discription
5819	26R Wet Cell Battery	Every standby generator requires a battery to start the system. Generac offers the recommended 26R wet cell battery for use with all air-cooled standby product.
5948 - 8 & 10kW 5947 - 14kW	Cold Weather Kit	If the temperature regularly falls below 32° F, install a cold weather kit to maintain optimal battery temperature. Kit consists of battery warmer with thermostat built into the wrap.
5621	Auxiliary Transfer Switch Contact Kit	The auxiliary transfer switch contact kit allows the transfer switch to lock out a single large electrical load you may not need.
5703	Paint Kit	Bisque Kit
5662 - 8kW 5663 - 10kW 5664 - 14kW	Scheduled Maintenance Kit	Generac's scheduled maintenance kits provide all the hardware necessary to perform complete routine maintenance on a Generac automatic standby generator.
5928	Nexus Wireless Remote	Completely wireless and battery powered, Generac's Nexus wireless remote monitor provides you with instant status information without ever leaving the house.
5951	Advanced Nexus Wireless Remote	Remotely control generator functions with the advanced model's LCD display. In addition to remote testing of the generator, set the excercise cycle and maintenance interval reminders
5937	DLM Load Control DLM Module (50 Amps)	DLM Modules are used in conjunction with the Nexus Smart Switch to increase its load management capabilities. It gives the Nexus Smart Switch additional load management flexibility not found in any other transfer switch.

Design and specifications subject to change without notice. Dimensions shown are approximate. Contact your Generac dealer for certified drawings. DO NOT USE THESE DIMENSIONS FOR INSTALLATION PURPOSES.

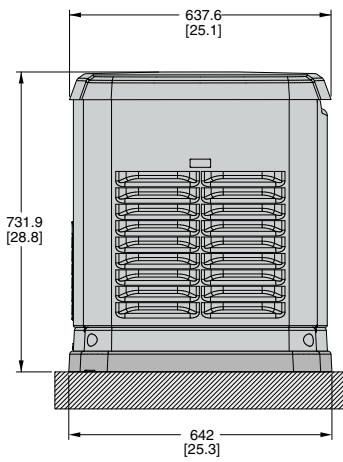

LEFT SIDE VIEW

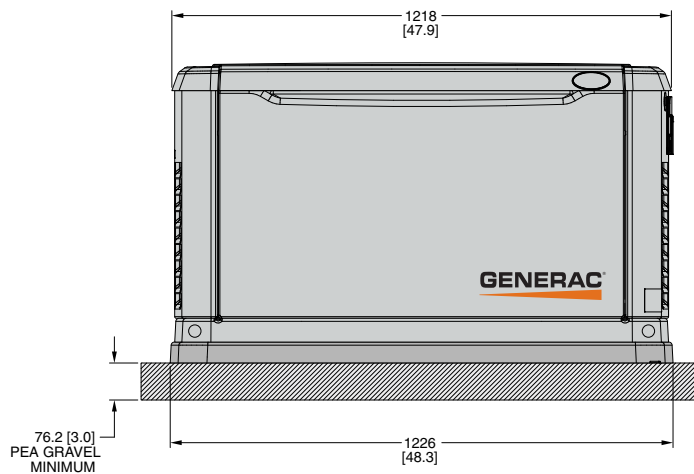

FRONT VIEW