

# SONY®

4-196-712-11(1)

## IC Recorder

### Operating Instructions

Getting Started

Basic Operations

Other Recording Operations

Other Playback Operations

Editing Files

About the Menu Function

Utilizing Your Computer

Additional Information

Troubleshooting

Index

<http://www.sony.net/>



\* 4 1 9 6 7 1 2 1 1 \* (1)

© 2011 Sony Corporation

Printed in China

## ***IC RECORDER***

ICD-SX712

## Owner's Record

The model number is located at the rear panel and the serial number is located inside the battery compartment. Record these numbers in the space provided below. Refer to these numbers whenever you call upon your Sony dealer regarding this product.

Model No. \_\_\_\_\_  
Serial No. \_\_\_\_\_

The following FCC statement applies only to the version of this model manufactured for sale in the USA. Other versions may not comply with FCC technical regulations.

## INFORMATION

This equipment has been tested and found to comply with the limits for a Class B digital device, pursuant to Part 15 of the FCC Rules. These limits are designed to provide reasonable protection against harmful interference in a residential installation. This equipment generates, uses and can radiate radio frequency energy and, if not installed and used in accordance with the instructions, may cause harmful interference to radio communications.

However, there is no guarantee that interference will not occur in a particular installation. If this equipment does cause harmful interference to radio or television reception, which can be determined by turning the equipment off and on, the user is encouraged to try to correct the interference by one or more of the following measures:

- Reorient or relocate the receiving antenna.
- Increase the separation between the equipment and receiver.
- Connect the equipment into an outlet on a circuit different from that to which the receiver is connected.
- Consult the dealer or an experienced radio/TV technician for help.

You are cautioned that any changes or modifications not expressly approved in this manual could void your authority to operate this equipment.

If you have any questions about this product, you may call: Sony Customer Information Service Center 1-800-222-7669 or <http://www.sony.com/>

## Declaration of Conformity

Trade Name : SONY  
Model : ICD-SX712  
Responsible Party : Sony Electronics Inc.  
Address : 16530 Via Esprillo,  
San Diego, CA 92127 USA  
Telephone Number : 858-942-2230

This device complies with part 15 of the FCC Rules. Operation is subject to the following two conditions: (1) This device may not cause harmful interference, and (2) this device must accept any interference received, including interference that may cause undesired operation.

## RECYCLING NICKEL METAL HYDRIDE BATTERIES

Nickel metal hydride batteries are recyclable.

You can help preserve our environment by returning your used rechargeable batteries to the collection and recycling location nearest you.

For more information regarding recycling of rechargeable batteries, call toll free 1-800-822-8837, or visit <http://www.rbrc.org/>.

**Caution:** Do not handle damaged or leaking nickel metal hydride batteries.



- The recorded music is limited to private use only. Use of the music beyond this limit requires permission of the copyright holders.
- Sony is not responsible for incomplete recording/ downloading or damaged data due to problems of the IC recorder or computer.
- Depending on the types of the text and characters, the text shown on the IC recorder may not be displayed properly on device. This is due to:
  - The capacity of the connected IC recorder.
  - The IC recorder is not functioning normally.
  - Content information is written in the language or the character that is not supported by the IC recorder.

## Notice for users

All rights reserved. This manual or the software described herein, in whole or in part, may not be reproduced, translated or reduced to any machine readable form without prior written approval from Sony Corporation.

IN NO EVENT SHALL SONY CORPORATION BE LIABLE FOR ANY INCIDENTAL, CONSEQUENTIAL OR SPECIAL DAMAGES, WHETHER BASED ON TORT, CONTRACT, OR OTHERWISE, ARISING OUT OF OR IN CONNECTION WITH THIS MANUAL, THE SOFTWARE OR OTHER INFORMATION CONTAINED HEREIN OR THE USE THEREOF.

Sony Corporation reserves the right to make any modification to this manual or the information contained herein at any time without notice. The software described herein may also be governed by the terms of a separate user license agreement.

- This software is for Windows and cannot be used for Macintosh.
- The supplied connecting cable is for the IC recorder ICD-SX712. You cannot connect other IC recorders.

What you record is for personal enjoyment and use only. Copyright laws prohibit other forms of use without the permission of the copyright holders. The use of Memory Stick™ media for recording copyright-protected graphics or other data is limited to the restrictions specified under applicable copyright laws. Any use beyond those restriction is prohibited.

This product supports “Memory Stick Micro™ (M2™)” media. “M2™” is an abbreviated form of “Memory Stick Micro™.” Hereinafter, “M2™” is used in this document.

## Trademarks

- Microsoft, Windows, Windows Vista and Windows Media are registered trademarks or trademarks of Microsoft Corporation in the United States and/or other countries.
- Macintosh and Mac OS are trademarks of Apple Inc., registered in the USA and other countries.
- Pentium is a registered trademark of Intel Corporation.
- MPEG Layer-3 audio coding technology and patents licensed from Fraunhofer IIS and Thomson.
- microSD and microSDHC logos are trademarks of SD-3C, LLC.



- “Memory Stick Micro,” “M2” and  are trademarks or registered trademarks of Sony Corporation.
- “MagicGate” is a trademark of Sony Corporation.
- Nuance, the Nuance logo, Dragon, Dragon NaturallySpeaking, and RealSpeak are trademarks and/or registered trademarks of Nuance Communications Inc., and/or its affiliates in the United States and/or other countries.
- US and foreign patents licensed from Dolby Laboratories.

All other trademarks and registered trademarks are trademarks or registered trademarks of their respective holders. Furthermore, “™” and “®” are not mentioned in each case in this manual.

The “Sound Organizer” uses software modules as shown below:  
Windows Media Format Runtime

# Table of Contents

## Getting Started

Step 1: Checking the Contents of the Package .....	8
Index to parts and controls .....	9
Preventing unintentional operations (HOLD) .....	11
Step 2: Recharging the Batteries .....	12
Recharging the batteries using a computer .....	12
Recharging the batteries using a USB AC adaptor .....	14
When to charge/replace the batteries .....	14
Step 3: Turning the IC Recorder On .....	15
Turning the power on .....	15
Turning the power off .....	15
Step 4: Setting the Clock .....	16
Setting the clock after recharging the batteries .....	16
Setting the clock using the menu .....	16
Step 5: Setting the Language to Be Used in the Display Window .....	19

## Basic Operations

Recording .....	20
Listening .....	25
Erasing .....	31

## Other Recording Operations

Changing the Recording Settings .....	33
Switching the directionality of the built-in microphones .....	33
Selecting a recording scene for each situation .....	34
Manual recording .....	39
Adding a recording to a previously recorded file .....	40
Adding an overwrite recording during playback .....	42
Recording a few seconds in advance – the pre-recording function .....	43
Starting to record automatically in response to sound – the VOR function .....	45
Recording on a Memory Card .....	47
Recording across memory media – cross-memory recording .....	50
Recording via Other Devices .....	52
Recording with an external microphone .....	52
Recording from other equipment .....	53
Operating during Recording .....	57
Monitoring the recording .....	57

## Other Playback Operations

Changing the Playback Settings .....	58
Convenient playback methods .....	58
Selecting a recording date from the calendar and playing back .....	59
Reducing noise in the playback sound and making the human voice clearer – the noise cut function .....	60
Adjusting the playback sound by amplifying inaudible sound – the digital voice up function .....	61
Adjusting the playback speed and tones – the DPC (Digital Pitch Control) function, key control .....	63
Selecting the sound effect .....	64
Selecting the playback mode .....	66
Playing Back a File at a Desired Time with an Alarm .....	68
Playback via Other Devices .....	71
Recording with other equipment .....	71

## Editing Files

Arranging Files in a Folder .....	72
Moving a file to a different folder .....	72
Copying a file to the other memory media .....	73
Erasing all files in a folder .....	74
Using a Track Mark .....	76
Adding a track mark .....	76
Erasing a track mark .....	77
Erasing all the track marks in the selected file at one time .....	77

Dividing a File .....	79
Dividing a file at the current position .....	79
Dividing a file at all the track mark positions .....	80
Changing a Folder Name .....	82
Protecting a File .....	84

## About the Menu Function

Making Settings for the Menu .....	85
Menu Settings .....	86

## Utilizing Your Computer

Using the IC Recorder with Your Computer .....	103
Connecting the IC recorder to your computer .....	103
Structure of folders and files .....	104
Disconnecting the IC recorder from your computer .....	108
Copying Files from the IC Recorder to Your Computer .....	109
Copying Music Files from Your Computer to the IC Recorder and Playing Them Back .....	110
Copying a music file from your computer to the IC recorder (drag and drop) .....	110
Playing back music files copied from your computer using the IC recorder .....	110

Using the IC Recorder as USB Memory .....	112
Using the Supplied Sound Organizer Software .....	113
What you can do using Sound Organizer .....	113
System requirements for your computer .....	114
Installing Sound Organizer .....	116
The Sound Organizer window .....	117

## **Additional Information**

Using a USB AC Adaptor .....	119
Disconnecting the IC recorder from the AC outlet .....	120
Precautions .....	121
Specifications .....	124
System requirements .....	124
Design and specifications .....	125
Battery life .....	128

## **Troubleshooting**

Troubleshooting .....	130
Message List .....	140
System Limitations .....	145
Display Window Guide .....	147
Index .....	152

# Step 1: Checking the Contents of the Package

### IC Recorder (1)

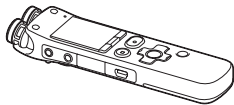

Remove the film on the display window before you use the IC recorder.

### Stereo headphones (1)



### USB connecting cable (1)

### Wind screen\* (1)



Use this to cover the built-in microphones.

### Cradle\* (1)

### Stand (1)

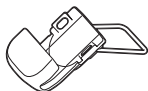

Application software, Sound Organizer (CD-ROM) (1)

Application software, Dragon NaturallySpeaking (DVD-ROM)\* (1)

Carrying pouch (1)

NH-AAA (size AAA) rechargeable batteries\* (2)

LR03 (size AAA) alkaline batteries\* (2)

Battery case\* (1)

### Operating Instructions

\* The wind screen, cradle, application software, Dragon NaturallySpeaking (DVD-ROM), LR03 (size AAA) alkaline batteries, NH-AAA (size AAA) rechargeable batteries and battery case are supplied with some models in some regions only.

You are cautioned that any changes or modifications not expressly approved in this manual could void your authority to operate this equipment.

## Index to parts and controls

### Front

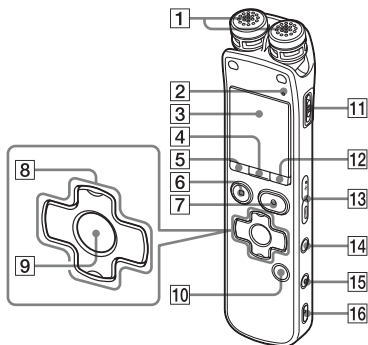

- 1 Built-in microphones (stereo)
- 2 Operation indicator
- 3 Display window
- 4 SCENE button
- 5 (folder) button
- 6 ■ STOP button
- 7 ● REC (record)/PAUSE button
- 8 Control button (▲, ▼ / ◀▶ (review/fast backward), ▶▶ (cue/fast forward))
- 9 ▶ (play)/ENT (enter) button\*
- 10 T-MARK (Track mark) button

- 11 POWER/HOLD switch
- 12 MENU button
- 13 VOLUME -/+\* button
- 14 ↶ (repeat) A-B button
- 15 ERASE button
- 16 Strap hole (A strap is not supplied.)

### Rear

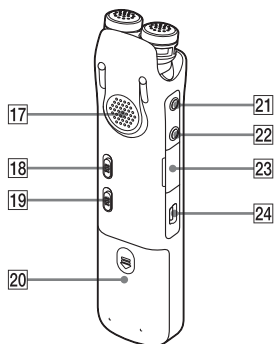

- 17 Speaker
- 18 NOISE CUT switch
- 19 DPC(SPEED)/KEY CTRL switch
- 20 Battery compartment
- 21 (microphone) jack\*
- 22 (headphone) jack

**23** M2™/microSD memory card slot

**24**  (USB) connector

\* These buttons and the jack have a tactile dot.  
Use it as a reference point for operations, or  
to identify each terminal.

## Preventing unintentional operations (HOLD)

You can disable all the buttons (HOLD) in order to prevent unintentional operations when you carry the IC recorder, etc.

### To put the IC recorder in the HOLD status

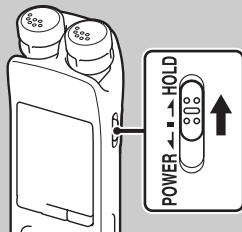

Slide the POWER/HOLD switch in the direction of “HOLD.”

“HOLD” will appear for approximately 3 seconds, indicating that all the button operations are disabled.



## To release the IC recorder from the HOLD status

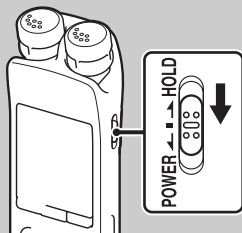

Slide the POWER/HOLD switch towards the center.

### Note

When the HOLD function is activated during recording, all the button operations are disabled. To stop recording, cancel the HOLD function first.

### Tip

Even if the HOLD function is activated, you can stop the alarm playback by pressing any button. (You cannot stop normal playback.)

## Step 2: Recharging the Batteries

### Note

The NH-AAA (size AAA) rechargeable batteries are supplied with some models in some regions only.

### Recharging the batteries using a computer

Remove the film on the display window before you use the IC recorder. Connect the IC recorder to a running computer, and charge the batteries until the battery indicator indicates “Full.” It takes about 4 hours to fully charge exhausted batteries.\*

- 1 Insert rechargeable batteries.  
Slide and lift the battery compartment lid, insert two NH-AAA rechargeable batteries with correct polarity, and close the lid.

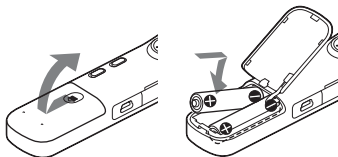

- 2 Connect the IC recorder to your computer.

Use the USB connecting cable supplied with the IC recorder to connect the  $\Psi$  (USB) connector of the IC recorder and the USB port of your computer.

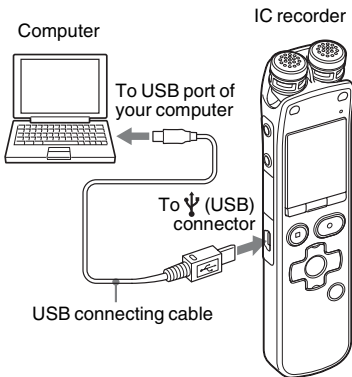

While the batteries are charging, “Connecting” and the battery indicator are displayed in an animation.

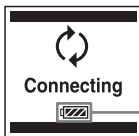

Battery indicator

When the batteries are fully charged, the battery indicator will indicate “**FULL**.”

### 3 Disconnect the IC recorder from your computer.

Follow the procedures below; otherwise, when the IC recorder contains data files, the files may be damaged or become unplayable.

- ① Make sure that the operation indicator of the IC recorder does not light.
- ② Perform the following operation on your computer.  
On a Windows screen, left-click the icon at the bottom of the desktop of the computer.



→ Left-click “Eject IC RECORDER.”

The icon and menu displayed can be different on different operating systems. On a Macintosh screen, drag “IC RECORDER” on the desktop to “Trash” and drop it there.

For details on disconnecting the IC recorder from your computer, refer to the operating instructions supplied with your computer.

- ③ Disconnect the IC recorder from the USB port of the computer.

\* This is an approximation for the time it takes to charge from no remaining battery power to full battery power at room temperature. It varies depending on the remaining power and the condition of the batteries. It also takes more time if the temperature of the batteries are low, or if the batteries are charged while you are transferring data to the IC recorder.

#### **Note**

If the battery indicator is not displayed in an animation, charging has not been done properly. See “Troubleshooting” on page 130.

### **When using fully charged batteries or LR03 (size AAA) alkaline batteries**

Follow the step 1.

#### **Note**

You cannot charge LR03 (size AAA) alkaline batteries.

## Tips

- Do not use manganese batteries for this IC recorder.
- When replacing the batteries, files recorded or alarm settings are not erased even when you remove the batteries.
- When replacing the batteries, the clock continues moving for about 1 day after you remove the batteries.

## Recharging the batteries using a USB AC adaptor

You can also charge the batteries by using an AC-U501AD USB AC adaptor, etc. (not supplied) (page 119).

## When to charge/replace the batteries

The battery indicator on the display shows the battery condition in an animation.

## Battery remain indication

 : “Low Battery Level” appears.  
Charge the rechargeable batteries or replace the old batteries with new ones.



 : “Low Battery” appears and the IC recorder will stop operation.

## Step 3: Turning the IC Recorder On

### Turning the power on

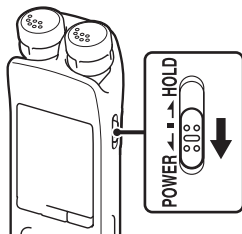

Slide the POWER/HOLD switch in the direction of “POWER” for more than 1 second. The IC recorder is turned on, and the “Accessing...” animation is displayed.

### Turning the power off

Slide the POWER/HOLD switch in the direction of “POWER” for more than 2 seconds, and the “Power Off” animation is displayed.

### 💡 Tips

- When you are not going to use the IC recorder for a long time, we recommend to turn off the IC recorder.
- When the IC recorder is in the stop mode, and you leave the IC recorder without attempting an operation for a certain length of time, the auto power off function will take effect. (The length of time before auto power off is set to “10min” when you purchase the IC recorder.) You can select the length of time before auto power off takes effect in the menu (page 101).

## Step 4: Setting the Clock

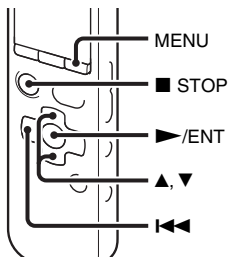

You need to set the clock to use the alarm function or record the date and time. When you insert batteries for the first time, or when you insert batteries after the IC recorder has been without batteries for more than 1 day, the “Set Date&Time” animation appears, and then the year section begins to flash in the clock setting display window.

### Setting the clock after recharging the batteries

- 1 Press ▲ or ▼ on the control button to set the year, month, day, hour, and minute in sequence, and then press ►/ENT.

Select the last two digits of the year when you set the year.

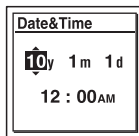



- 2 Press ■ STOP to return to the stop mode display.

### Setting the clock using the menu

While the IC recorder is in the stop mode, you can set the clock using the menu.

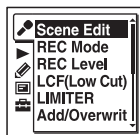
- 1 Select “Date&Time” in the menu.
  - ① Press MENU to enter the menu mode. The menu mode window will be displayed.



- ② Press **◀◀** on the control button, press **▲** or **▼** on the control button to select the  (IC recorder setting) tab, and then press **▶/ENT**.
- ③ Press **▲** or **▼** on the control button to select “Date&Time,” and then press **▶/ENT**.

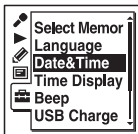

- 2 Press **▲** or **▼** on the control button to select “Auto” or “Manual,” and then press **▶/ENT**.



When you selected “Auto,” the clock is automatically adjusted using the clock in the computer connected to the IC recorder and on which the supplied Sound Organizer software is started. When you select “Manual,” proceed to the next steps.

- 3 Press **▲** or **▼** on the control button to select “10y 1m 1d,” and then press **▶/ENT**.

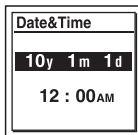

- 4 Press **▲** or **▼** on the control button to set the year, month, day, hour, and minute in sequence, and then press **▶/ENT**. Select the last two digits of the year when you set the year.

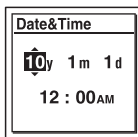

- 5 Press **■ STOP** to exit the menu mode.

#### **■ Note**

If you do not press **▶/ENT** within 1 minute of entering the clock setting data, the clock setting mode is canceled and the window will return to the display of the stop mode.

## To display the current date and time

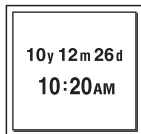

While the IC recorder is in the stop mode, press ■ STOP to display the current date and time for about 3 seconds.



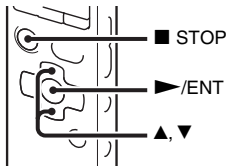



## Step 5: Setting the Language to Be Used in the Display Window

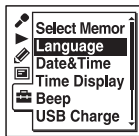

You can select the language to be used for messages, menus, folder names, file names, etc. from 3 languages.

- 1 Select the  (IC recorder setting) tab → “Language” in the menu, and then press /ENT.



- 2 Press  or  on the control button to select the language that you want to use, and then press /ENT.



You can select the following languages.  
English, Español (Spanish), Français (French)

- 3 Press  STOP to exit the menu mode.

# Recording

### ■ Notes

- Before making a recording, be sure to check the battery indicator (page 14).
- Noise may be recorded if an object, such as your finger, etc., accidentally rubs or scratches the IC recorder during recording.

### 💡 Tip

Before you start recording, we recommend you make a trial recording first, or monitor the recording (page 57).

## Switching the directionality of the built-in microphones

---

- 1 Change the angle of the built-in microphones manually according to the direction you want to record (page 33).

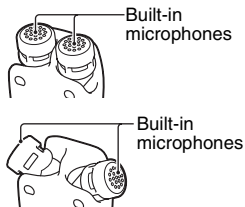





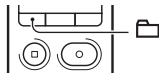

## Selecting a folder

---

- 1 Slide the POWER/HOLD switch towards the center to release the IC recorder from the HOLD status (page 11).



- 2 Press  to display the folder selection window.

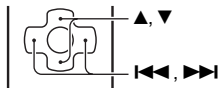

- 3 Press  on the control button, press  or  on the control button to select the  (Voice) tab, and then press  on the control button.



#### Note

Only the  (Voice) tab will be displayed when you purchase the IC recorder. The  (Music) tab and the  (Podcast) tab will be displayed when you transfer files from your computer (page 110, 114).

The  (Built-in memory) tab will be displayed when you insert a memory card into the IC recorder (page 48).

- 
- 4** Press ▲ or ▼ on the control button to select the folder in which you want to record files.

When you purchase the IC recorder, there are 5 folders already available (📁 FOLDER01-05).

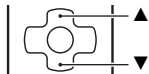

- 
- 5** Press ►/ENT.

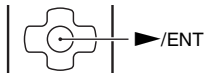

## Starting to record (Auto (AGC) recording)

---

- 1** Turn the built-in microphones in the direction of the source to be recorded.

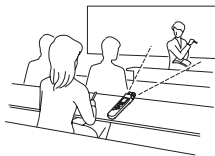

## 2 Press ● REC/PAUSE in the stop mode.

The operation indicator lights in red.

You do not need to press and hold ● REC/PAUSE while recording.

The new file will be automatically recorded after the last recorded file.

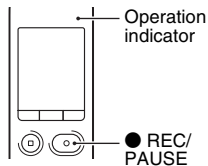
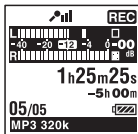

## To stop recording

### 1 Press ■ STOP.

The operation indicator flashes in orange and the IC recorder stops at the beginning of the current recording file.



## Note while accessing

The IC recorder is recording data and storing it on the memory media when the operation indicator flashes in orange. While the IC recorder is accessing data, do not remove the batteries or connect or disconnect the USB AC adaptor (not supplied). Doing so may damage the data.

## Other operations

---

pause recording*	Press ● REC/PAUSE. During recording pause, the operation indicator flashes in red and “●  ” begins to flash in the display window.
release pause and resume recording	Press ● REC/PAUSE again. Recording resumes from that point. (To stop recording after pausing recording, press ■ STOP.)
review the current recording instantly**	Press ►/ENT. Recording stops and playback starts from the beginning of the file just recorded.
review during recording**	Press and hold ◀◀ on the control button during recording or recording pause. Recording stops and you can search backwards while listening to fast playback sound. After you release ◀◀ on the control button, playback starts from that point.

---

\* 1 hour after you pause recording, recording pause is automatically released and the IC recorder enters the stop mode.

\*\* You cannot select this function in the manual recording mode.

### Tips

- You can record up to 199 files in each folder.
- You can make new folders or erase unwanted folders using the supplied Sound Organizer software (page 113).
- When a memory card has been inserted, you can continue recording a file by changing the location of the folder used to store the file from the built-in memory to the memory card automatically after the built-in memory is full (Cross-memory recording) (page 50).





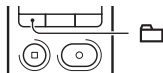

# Listening

## Starting playback

- 1 Slide the POWER/HOLD switch towards the center to release the IC recorder from the HOLD status (page 11).

- 2 Press .



- 3 Press  on the control button, press  or  on the control button to select the  (Voice) tab, the  (Music) tab, or the  (Podcast) tab, and then press  on the control button.

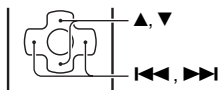

- 4 Press  or  on the control button to select the folder.



**5** Press **▶▶** on the control button.

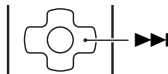

**6** Press **▲** or **▼** on the control button to select the file you want to play.

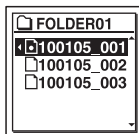

**7** Press **▶/ENT**.

Playback will start soon, and the operation indicator will light in green. (When "LED" is set to "OFF" in the menu (page 98), the operation indicator does not light.)

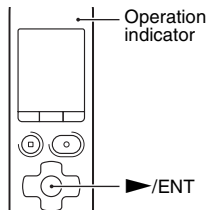

**8** Press **VOLUME -/+** to adjust the volume.



## To stop playback

- 1 Press ■ STOP.



## Other operations

stop at the current position (Playback Pause function) Press ►/ENT. To resume playback from that point, press ►/ENT again.

go back to the beginning of the current file Press ◀◀ on the control button once.\*1\*2

go back to previous files Press ◀◀ on the control button repeatedly. (During the stop mode, keep the button pressed to go back the files continuously.\*3)

skip to the next file Press ▶▶ on the control button once.\*1\*2

skip to the succeeding files Press ▶▶ on the control button repeatedly. (During the stop mode, keep the button pressed to skip the files continuously.\*3)

\*1 When a track mark is set, the IC recorder goes backward or forward to the track mark before or after the current point (page 76).

\*2 These operations are for when “Easy Search” is set to “OFF” (page 58).

\*3 In the continuous searching mode, the IC recorder does not locate track marks.

## About the tab view

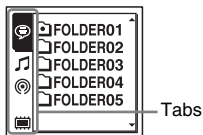

The recordable area and the playback-only area of folders stored on the IC recorder are managed separately, and are displayed with tabs. When you choose a folder, you can move to one of those areas by switching a tab.





 (Voice): Recordable area. This is the area used to manage files recorded with the IC recorder.

 (Music): Playback-only area. This is the area used to manage music files transferred from your computer.

 (Podcast): Playback-only area. This is the area used to manage podcast files transferred from your computer.

 (Built-in memory) or  (External memory): You can switch between the built-in memory and external memory (memory card) of the IC recorder (page 49).

Only the  (Voice) tab will be displayed when you purchase the IC recorder. The

 (Music) tab and the  (Podcast) tab will be displayed when you transfer files from your computer (page 110, 114).

The  (Built-in memory) tab will be displayed when you insert a memory card into the IC recorder (page 48).

## Display when playing back a file

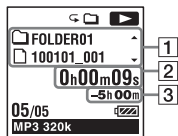

### 1 File information

Press ▲ or ▼ on the control button to check the file information during playback.  
A file recorded using the IC recorder is displayed as follows.



 : Folder name: FOLDER01-FOLDER05

 : File name: Date\_file number (e.g. 100101\_001)



 : Artist name (e.g. My Recording)

 : Title: Date\_file number (e.g. 100101\_001)



Playback level meter

## 2 Counter information

You can select the display mode in the menu (page 98).

Elapsed time: The elapsed playback time of one file

Remaining time: The remaining playback time of one file

Recording date: Date recorded

Recording time: Time recorded

## 3 Remaining recording time

Displays the remaining recording time in hours, minutes, and seconds.

If there is more than 10 hours time remaining, the time is displayed in hours.

If there is more than 10 minutes and less than 10 hours time remaining, the time is displayed in hours and minutes.

If there is less than 10 minutes time remaining, the time is displayed in minutes and seconds.

# Erasing

## ■ Note

Once a recording has been erased, you cannot retrieve it.

## Selecting a file and erasing it

- Slide the POWER/HOLD switch towards the center to release the IC recorder from the HOLD status (page 11).
- Select the file you want to erase when the IC recorder is in the stop or playback mode.
- Press ERASE.  
“Erase?” is displayed and the specified file is played back for confirmation.
- Press ▲ or ▼ on the control button to select “Execute.”

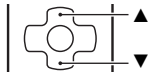
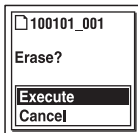
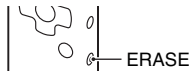

---

**5** Press ►/ENT.

The “Erasing...” animation appears in the display window and the selected file will be erased.

When a file is erased, the remaining files will advance so that there will be no space between files.



---

## To cancel erasing

**1** Select “Cancel” in step 4 of “Selecting a file and erasing it,” and then press ►/ENT.



## To erase another file

Proceed with steps 2 through 5 in “Selecting a file and erasing it.”

## To erase a part of a file

Divide the file into two files first (page 79), and then proceed with steps 2 through 5 in “Selecting a file and erasing it.”

# Changing the Recording Settings

## Switching the directionality of the built-in microphones

The built-in microphones are unidirectional. You can change the angle of the built-in microphones manually.

## Rotating both capsules of the built-in microphones in the same direction (0° position)



You can record the sound directly in front of the built-in microphones. This is convenient when you want to record a sound source in a particular direction, such as a voice note, an interview, etc.

## Rotating both capsules of the built-in microphones to face the outside (120° position)

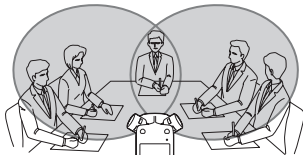

The microphone on the right records sound from the right; the microphone on the left records sound from the left. You can thus obtain dynamic stereo sound recording, therefore this position is recommended for recording a sound source, such as a conference, a musical performance, etc.

## Selecting a recording scene for each situation

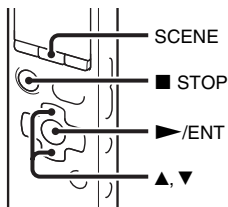

According to various recording scene, you can change the items for recording, such as REC Mode (page 89), REC Level (page 90), etc., to the recommended settings in bulk. You can change the settings for each item.

- 1 Press SCENE in the stop mode.  
The Scene Select window will be displayed.
- 2 Press ▲ or ▼ on the control button to select the scene you want, and then press ►/ENT.



---

 (Meeting) To record in a variety of situations, such as recording in a spacious conference room.

---

 (Voice Notes) To record dictation with a microphone in front of your mouth.

---

 (Interview) To record human voice at a distance of 1 to 2 meters (40 to 80 in.). When you rotate both capsules of the built-in microphones in the same direction (0° position), the directionality effect of the microphones will be improved.

---

 (Music) To record acoustic guitar, piano, violin, or other instrumental sounds at a distance of 2 to 3 meters (80 to 120 in.).

---

 (My Scene) Use to store your favorite settings.

### Notes

- You cannot set a scene during recording.
- When 60 seconds have passed without any operation after the Scene Select window

appears in step 1, the stop mode display will be displayed.

There are ways of making settings to record well other than using scene selection.

## Recording at a meeting

- When you record a voice coming from a specific direction, set the angle of the built-in microphones to 0°. When you record voices from unspecified directions, set the angle of the built-in microphones to 120° (page 33).
- By placing the IC recorder on the supplied stand, you can record with clear and low-noise sound, without vibration noise from the desk.

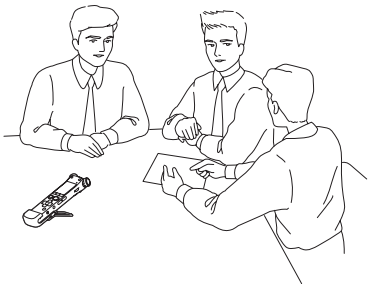

## Recording a voice note

Set the angle of the built-in microphones to 0° (page 33).

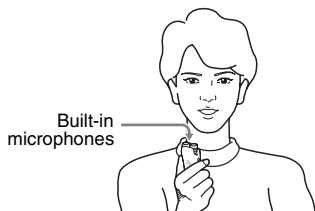

## Recording an interview

Set the angle of the built-in microphones to 0° (page 33).



## Recording music

- Set the angle of the built-in microphones to 120° (page 33).
- By attaching a tripod (not supplied) using the supplied stand, you can adjust the angles of the IC recorder and the built-in microphones more precisely.

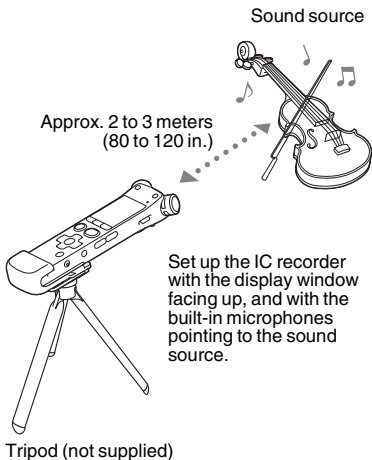

## To change the Scene Select settings using the menu

- 1 Select the (Recording) tab → “Scene Edit” in the menu, and then press **▶/ENT**.



- 2 Press **▲** or **▼** on the control button to select the scene you want to change the settings, and then press **▶/ENT**.



- 3 Press ▲ or ▼ on the control button to select “Edit from Current Setting” or “Edit,” and then press ►/ENT.



- 4 Press ▲ or ▼ on the control button to select the menu item you want to change, and then press ►/ENT.



- 5 Press ▲ or ▼ on the control button to select a setting item, and then press ►/ENT.  
For details on the menu items and settings, see pages 89 through 93.

- 6 Press ▲ or ▼ on the control button to select “Edit Complete,” and then press ►/ENT.

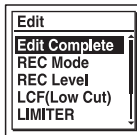







- 7 Press ■ STOP to exit the menu mode.



## To set the menu item settings of the Scene Select to the default values

- 1 Select “Set Default Value” in step 3 of “To change the Scene Select settings using the menu,” and then press ►/ENT.  
“Default Value?” will be displayed.
- 2 Press ▲ or ▼ on the control button to select “Execute,” and then press ►/ENT.  
The menu item settings will be set to the default settings.
- 3 Press ■ STOP to exit the menu mode.

## Default settings

For details on the menu items and settings, see pages 89 through 93.

	 (Meeting)	 (Voice Notes)	 (Interview)
REC Mode	MP3 192kbps	MP3 128kbps	MP3 192kbps
REC Level	Medium 	Low 	Medium 
REC Level Value	–	–	–
LCF(Low Cut)	ON	ON	ON
LIMITER	–	–	–
VOR	OFF	OFF	OFF
SYNC REC	OFF	OFF	OFF
Select Input	MIC IN	MIC IN	MIC IN

	 (Music)	 (My Scene)
REC Mode	LPCM 44.1kHz/16bit	LPCM 44.1kHz/16bit
REC Level	Low(Music) 	Manual <b>MAN</b>
REC Level Value	–	10
LCF(Low Cut)	OFF	OFF
LIMITER	–	ON
VOR	OFF	–
SYNC REC	OFF	OFF
Select Input	MIC IN	MIC IN

## Manual recording

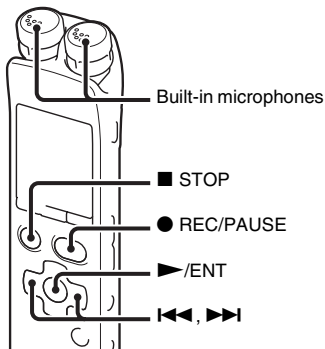

When you set “REC Level” to “Manual **MAN**,” you can adjust the recording level manually, according to the sound source. If necessary, you can also utilize the “LIMITER” setting (page 91) in the menu to reduce sound distortion.

- 1 Set “REC Level” to “Manual **MAN**” in the menu (page 90).

- 2 Select a folder.

For details, see “Selecting a folder” (page 20).



- 3 Turn the built-in microphones in the direction of the source to be recorded.
- 4 Press and hold ● REC/PAUSE.

The IC recorder enters the recording standby mode. When the microphones pick up sound, the level meter in the display window moves.

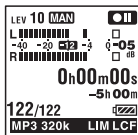

- 5 Press ◀◀ or ▶▶ on the control button to adjust the recording level, depending on the sound source.

You can check the recording level value with the peak meter of the display window. Adjust the level closer to  $-12$  dB, into a range that is appropriate for your sound source.

If “OVER” is displayed, press **◀◀** on the control button to adjust the recording level down so that “OVER” is not displayed, to prevent sound distortion.

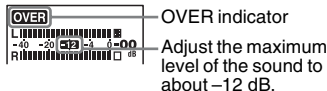

Press and hold **◀◀** or **▶▶** on the control button to change the REC Level value continuously. The sound level is also displayed as a number right side of the level meter.

- 6** Make other settings according to the state of recording.

If necessary, utilize the “LIMITER” setting in the menu (page 91).

- 7** To start recording, press **● REC/ PAUSE**.

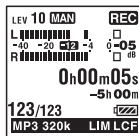

- 8** To stop recording, press **■ STOP**.

### Notes

- In the manual recording mode, you cannot record with the VOR function (page 45).
- In the manual recording mode, you cannot review the current recording, even if you press **▶/ENT**.

## Adding a recording to a previously recorded file

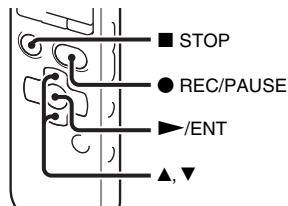

When “Add/Overwrite” in the menu is set to “Add,” you can add a recording to the file being played back. The added recording will be placed after the current file, and will be counted as a part of the file.

During playback of file 3

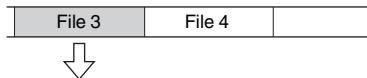

After adding a recording

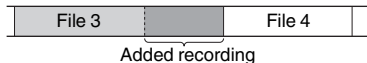

Select the file to which you want to add a recording first.

- 1 Select the  (Recording) tab → “Add/Overwrite” in the menu, and then press **▶/ENT**.



- 2 Press **▲** or **▼** on the control button to select “Add,” and then press **▶/ENT**.

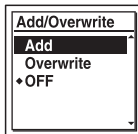

“Add/Overwrite” is set to “OFF” when you purchase the IC recorder.

- 3 Press **■ STOP** to exit the menu mode.
- 4 When the file to be added is played back, press **● REC/PAUSE**.  
“Add REC?” will be displayed.  
For details on playback, see page 25.
- 5 While “Add REC?” is displayed, press **● REC/PAUSE**.  
The operation indicator will turn red.  
Then recording starts.

- 6 To stop recording, press **■ STOP**.

#### **■ Notes**

- You cannot add a recording when the file has reached the maximum size limit (2 GB with LPCM files and 1 GB with MP3 files).
- You cannot add a recording to an LPCM file or an MP3 file that was not recorded using

the IC recorder. Moreover, when you edit files using the supplied Sound Organizer software, adding a recording to the files may not be possible.

- The REC Mode of an additional recording is the same as the added file.
- If 10 minutes have passed after step 4, you must start the procedure again from step 4.

## Adding an overwrite recording during playback

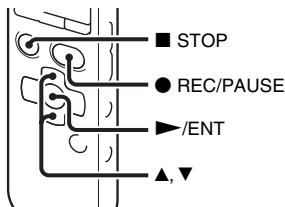

When “Add/Overwrite” in the menu is set to “Overwrite,” you can add an overwrite recording after a selected point in a recorded file. The part of the file after the selected point is erased.

The starting point of an overwrite recording

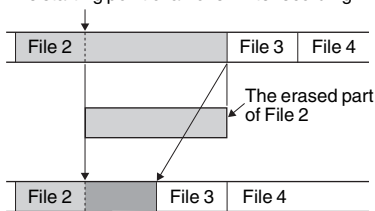

▲  
Added overwrite recording in File 2

Select the file to which you want to add an overwrite recording first.

- 1 Select the (Recording) tab → “Add/Overwrite” in the menu, and then press /ENT.



- 2 Press ▲ or ▼ on the control button to select “Overwrite,” and then press ►/ENT.



“Add/Overwrite” is set to “OFF” when you purchase the IC recorder.

- 3 Press ■ STOP to exit the menu mode.
- 4 When the file to be added is played back, press ● REC/PAUSE at the position where you want to overwrite the file. “Overwrite REC?” will be displayed. For details on playback, see page 25.
- 5 While “Overwrite REC?” is displayed, press ● REC/PAUSE. The operation indicator will turn red. Then recording starts.
- 6 To stop recording, press ■ STOP.

#### ■ Notes

- You cannot add an overwrite recording to an MP3 file when the file has reached the maximum size limit (1 GB). You can add an

overwrite recording to an LPCM file, even if the file has reached the maximum size limit (2 GB), when the beginning of the point to be overwritten has not reached the maximum size limit.

- You cannot add an overwrite recording to an LPCM file or MP3 file which was not recorded using the IC recorder. Moreover, when you edit files using the supplied Sound Organizer software, adding an overwrite recording to the files may not be possible.
- The REC Mode of an additional overwrite recording is the same as the added file.
- If 10 minutes have passed after step 4, you must start the procedure again from step 4.

## Recording a few seconds in advance – the pre-recording function

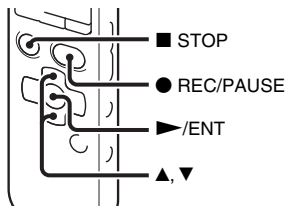

The pre-recording function allows you to record sound sources for approximately 5

seconds prior to the point when you press ● REC/PAUSE. This is useful for recording during interviews or when making an open-air recording so that you will not miss an opportunity to start recording.

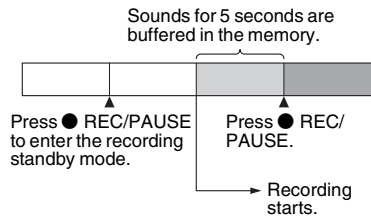

- 1 Select the (Recording) tab → “PRE REC” in the menu, and then press ►/ENT.



- 2 Press ▲ or ▼ on the control button to select “ON,” and then press ►/ENT. “PRE REC” is set to “OFF” when you purchase the IC recorder.

- 3 Press ■ STOP to exit the menu mode.
- 4 Select a folder.
- 5 Press and hold ● REC/PAUSE.

The IC recorder enters the recording standby mode.

Pre-recording starts and sounds for a maximum of the last 5 seconds are buffered in the memory.

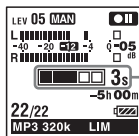

Displays how long the sound is buffered in the memory.

- 6 To start recording, press ● REC/PAUSE.

The standby for recording mode is released, and recording continues from the sound buffered in step 5.

- 7 To stop recording, press ■ STOP.

## ■ Notes

- If you start recording with pre-recording function using the built-in microphones, a click noise may be recorded when you press ● REC/PAUSE. To record with pre-recording function, we recommend using an external microphone.

- When the remaining recordable time is less than 10 seconds, the pre-recording function is disabled. Before starting to use the pre-recording function, erase unwanted files.
- When 60 minutes have passed after the IC recorder entered the standby mode in step 5, the standby mode will be canceled and recording stops.
- If you stop recording before step 6, sounds buffered in the memory will not be saved.

## To cancel the pre-recording function

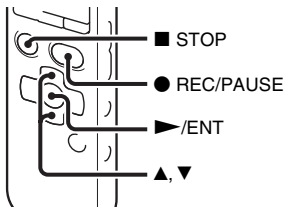

Set “PRE REC” to “OFF” in step 2.

## Starting to record automatically in response to sound – the VOR function









You can set the VOR (Voice Operated Recording) function to “ON,” to make the IC recorder start recording when the IC

recorder detects sound, and pause when no sound is heard, eliminating recording during soundless periods.

- 1 Select the  (Recording) tab → “VOR” in the menu when the IC recorder is in the stop or recording mode, and then press /ENT.



- 2 Press  or  on the control button to select “ON,” and then press /ENT. “VOR” is set to “OFF” when you purchase the IC recorder.
- 3 Press  STOP to exit the menu mode.
- 4 Press  REC/PAUSE. “VORREC” appears in the display window.

The recording pauses when no sound is detected and “VOR  ” flashes. When the IC recorder detects sound again, the recording starts again.

## To cancel the VOR function

Set “VOR” to “OFF” in step 2.

### Notes

- The VOR function is affected by the sound around you. Set “REC Level” in the menu according to the recording conditions. If recording is not satisfactory after you have changed the “REC Level” setting, or for an important recording, set “VOR” to “OFF” in the menu.
- If you press ● REC/PAUSE to pause recording during VOR recording, only “” flashes.
- During manual recording (page 39), pre-recording (page 43), and synchronized recording (page 54), the VOR function does not work.

# Recording on a Memory Card

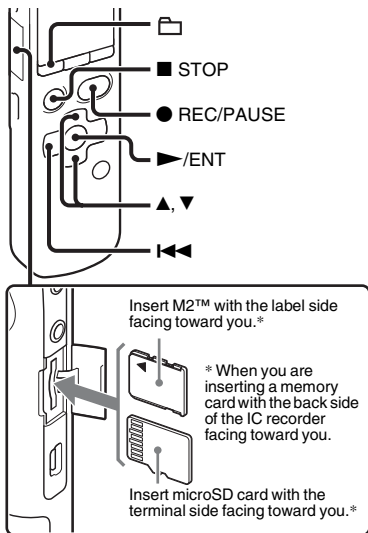

In addition to the built-in memory, you can record files on a memory card.

## About compatible memory cards

Memory cards that you can use with the IC recorder are as follows:

- Memory Stick Micro™ (M2™) media:  
Up to 16 GB is supported.
  - microSD card: A microSD (FAT16) card smaller than 2 GB and a microSDHC (FAT32) card from 4 GB to 32 GB are supported.
- A memory card of 64 MB or less is not supported.

The microSD/microSDHC cards that have been tested according to our standards are as follows.

### microSD/microSDHC cards

Supplier	2 GB	4 GB	8 GB	16 GB	32 GB
SONY	○	○	○	—	—
Toshiba	○	○	○	○	—
Panasonic	○	○	○	○	—
SanDisk	○	○	○	○	○

○: Operation tested

—: Operation not tested

As of September 2010

For ICD-SX712, the operational tests performed were using memory cards available as of September 2010.

For the latest information about the memory cards that have been tested, please access the support home page for the IC recorder: <http://www.sony.com/recordersupport>

In this manual, M2™ and microSD cards are generally referred to as a “memory card.”

The M2™/microSD card slot is referred to as the “memory card slot.”

Due to the file system specifications of the IC recorder, you can record and play back an LPCM file smaller than 2 GB, and an MP3/LPEC/WMA/AAC-LC file smaller than 1 GB using a memory card.

You can record up to 4,074 files on an M2™ media.

#### **Note**

Operations of all types of compatible memory cards are not guaranteed.

### **To insert a memory card**

Before recording, be sure to copy all the data stored on the memory card to your computer and format the memory card on the IC recorder (page 102) so it contains no data.

**1** Open the cover of the memory card slot in the stop mode.

**2** Insert an M2™ or microSD card, in the direction shown in the illustration on page 47, securely to the end of the slot until it clicks into place. Then close the cover.

### **To remove a memory card**

Push the memory card into the slot. When it pops out, remove it from the memory card slot.

### **Structure of folders and files**









5 folders are created in a memory card in addition to those in the built-in memory. The structure of folders and files is somewhat different from that of the built-in memory (page 106).

#### **Notes**



- Do not insert or remove a memory card during recording/playback/formatting. Doing so may cause a malfunction of the IC recorder.
- Do not remove a memory card while the “Accessing...” animation appears in the display window. Doing so may damage the data.
- If a memory card is not recognized, remove it and then insert it into the IC recorder again.

- Close the cover of the memory card slot firmly. Also, do not insert any liquid, metal, flammable or any object other than a memory card into the slot. Doing so may cause fire, electric shock, or malfunctions.

## To switch the IC recorder destination to the memory card (from the folder selection window)

- 1 Press .  
The folder selection window will be displayed.
- 2 Press  on the control button, press  or  on the control button to select the  (Built-in memory) tab, and then press /ENT.
- 3 Press  or  on the control button to select “Memory Card,” and then press /ENT.



The  (Built-in memory) tab changes to the  (External memory) tab, and

then the folder selection window will be displayed.

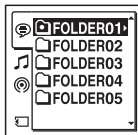



- 4 Press  STOP to return to the stop mode display.

## To use the built-in memory

Select “Built-In Memory” in step 3.

## To switch the IC recorder destination to the memory card (from the menu)

- 1 Select the  (IC recorder setting) tab → “Select Memory” in the menu, and then press /ENT.

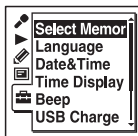

- 2 Press ▲ or ▼ on the control button to select “Memory Card,” and then press ►/ENT.



“Select Memory” is set to “Built-In Memory” when you purchase the IC recorder.

If the memory card has already been formatted, proceed to step 5.

- 3 When the memory card is not formatted, select the  (IC recorder setting) tab → “Format” in the menu, and then press ►/ENT.

“Erase All Data?” will be displayed.

- 4 Press ▲ or ▼ on the control button to select “Execute,” and then press ►/ENT.

- 5 Press ■ STOP to exit the menu mode.

### To use the built-in memory

Select “Built-In Memory” in step 2.

### To start recording



Select the folder and then press ● REC/ PAUSE.

For auto (AGC) recording, see page 22. For manual recording, see page 39.

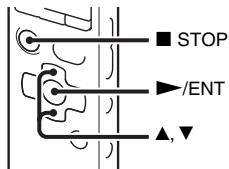



### Recording across memory media – cross-memory recording



When the memory media currently being used becomes full during recording, the IC recorder automatically switches its destination to the other memory media and continues recording (Cross-memory recording).

- 1 Select the  (Recording) tab → “Cross-Memory REC” in the menu, and then press .



- 2 Press  or  on the control button to select “ON,” and then press . “Cross-Memory REC” is set to “OFF” when you purchase the IC recorder.
- 3 Press  STOP to exit the menu mode.

## To cancel cross-memory recording

Set “Cross-Memory REC” to “OFF” in step 2.

## When the current memory media becomes full during recording

The “Continue REC in Other Memory” animation appears in the display window. Recording continues as a new file in a recordable folder of the smallest folder number available for the other memory media.

A new file created with a new file name.

## Notes

- If the other memory media is also full, a message is displayed and the IC recorder stops recording.
- When you play back the original file recorded with cross-memory recording, the IC recorder does not play the succeeding file automatically.
- Before attempting cross-memory recording, check to see if the IC recorder can switch the memory media to “Memory Card” in advance (page 49).
- Even if you insert a memory card into the IC recorder during recording, cross-memory recording will not work.
- When you are recording files with cross-memory recording, the sound may be partially interrupted after the memory media has been switched.

# Recording via Other Devices

## Recording with an external microphone

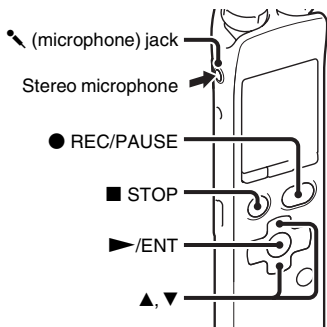

- 1 Connect an external microphone to the (microphone) jack when the IC recorder is in the stop mode.

“Select Input” appears in the display window.

If “Select Input” is not displayed, set it in the menu (page 93).

- 2 Press ▲ or ▼ on the control button to select “MIC IN,” and then press ►/ENT.



“Select Input” is set to “MIC IN” when you purchase the IC recorder.

- 3 Press ■ STOP to exit the menu mode.
- 4 Press ● REC/PAUSE to start recording.

The built-in microphones are automatically cut off.

If the input level is not strong enough, adjust the “REC Level” setting on the IC recorder.

When a plug in power type microphone is connected, power is automatically supplied to the microphone from the IC recorder.

### Recommended microphones

You can use the Sony ECM-CS10 electret condenser microphone (not supplied).

## To record sound from a telephone or a cell phone

You can use the ECM-TL1 headphone-type electret condenser microphone (not supplied) to record sound from a telephone or a cell phone.

Insert the earphone of the microphone into your ear, then, while holding the receiver to the ear with the earphone in it, connect the plug of the earphone to the

(microphone) jack of the IC recorder.

### Notes

- After you have made the connection, check the sound quality of the conversation and the recording level before you start recording.
- If the beep of the telephone or a dial tone is recorded, the conversation may be recorded with lower level of sound. In this case, start recording after the conversation has started.
- The VOR function (page 45) may not work, depending on the kind of telephone or the line condition.
- We assume no responsibility whatsoever for any inconvenience, even if you cannot record a conversation using the IC recorder.

## Recording from other equipment

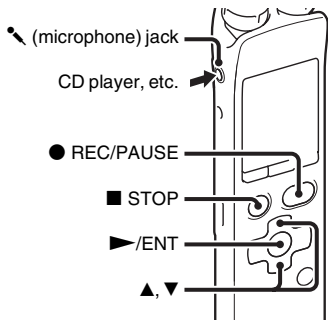

You can make music files without using the computer by recording sound from other equipment connected to the IC recorder.

### Tips

- Before you start recording, we recommend you make a trial recording first.
- If the input level is not strong enough, connect the headphone jack (minijack, stereo) of other equipment to the (microphone) jack of the IC recorder and adjust the volume level on the piece of equipment connected to the IC recorder.

## To record using the synchronized recording function

The IC recorder pauses when no sound is detected for more than 2 seconds. The IC recorder starts recording again as a new file when sound is detected.

- 1 Select the  (Recording) tab → “SYNC REC” in the menu, and then press **▶/ENT**.



- 2 Press **▲** or **▼** on the control button to select “ON,” and then press **▶/ENT**. “SYNC REC” is set to “OFF” when you purchase the IC recorder.
- 3 Press **■** STOP to exit the menu mode.
- 4 Connect other equipment to the IC recorder when the IC recorder is in the stop mode.  
Connect the audio output connector (stereo mini-plug) of other equipment to the  (microphone) jack of the IC

recorder using an audio connecting cable (page 126).

“Select Input” appears in the display window.

If “Select Input” is not displayed, set it in the menu (page 93).

- 5 Press **▲** or **▼** on the control button to select “Audio IN,” and then press **▶/ENT**.



“Select Input” is set to “MIC IN” when you purchase the IC recorder.



- 6 Press **●** REC/PAUSE to start recording. “SYNC  ” flashes and the IC recorder enters the recording pause mode.
- 7 Start playback on the piece of equipment connected to the IC recorder. “SYNC **REC**” appears on the display and synchronized recording starts.

The synchronized recording pauses when no sound is detected for more than 2 seconds, and “SYNC **OFF**” begins to flash. The IC recorder starts recording again as a new file when sound is detected.



### ■ Notes

- During synchronized recording, you cannot pause recording (page 24), record with the pre-recording function (page 43), record with the VOR function (page 45), record with the cross-memory recording function (page 50), and add a track mark (page 76).
- Depending on the piece of equipment connected to the IC recorder, the synchronized recording function may not operate properly due to a difference in the audio input level.

## To record without using the synchronized recording function

- 1 Select the  (Recording) tab → “SYNC REC” in the menu, and then press /ENT.



- 2 Press  or  on the control button to select “OFF,” and then press /ENT. “SYNC REC” is set to “OFF” when you purchase the IC recorder.



- 3 Press  STOP to exit the menu mode.

- 4 Connect other equipment to the IC recorder when the IC recorder is in the stop mode.

Connect the audio output connector (stereo mini-plug) of other equipment to the  (microphone) jack of the IC recorder using an audio connecting cable (page 126).

“Select Input” appears in the display window.

If “Select Input” is not displayed, set it in the menu (page 93).

- 5 Press  or  on the control button to select “Audio IN,” and then press /ENT.



“Select Input” is set to “MIC IN” when you purchase the IC recorder.



**6** Press ■ STOP to exit the menu mode.

**7** Press ● REC/PAUSE to start recording.  
The built-in microphones are automatically cut off and the sound from the connected equipment is recorded.

**8** Start playback on the piece of equipment connected to the IC recorder.

 **Tip**

When recording sound from other equipment, we recommend you set “REC Level” as follows.

<b>Equipment to be connected</b>	<b>“REC Level” setting</b>
Tape recorder, portable CD player, etc.	High(Music)  
CD player, etc.	Low(Music) 

# Operating during Recording

## Monitoring the recording

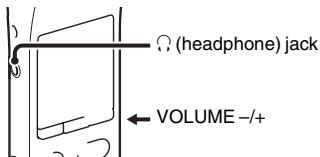

If you connect the supplied stereo headphones to the  (headphone) jack, you can monitor the recording. You can adjust the monitoring volume by pressing VOLUME  $-/+$ , but the recording level is fixed.



### **Note**

When the cord of the headphones touches the IC recorder while you are monitoring the recording, the IC recorder may record a rustling noise. The rustling noise can be reduced by holding the cord away from the IC recorder.





# Changing the Playback Settings

## Convenient playback methods



### Listening with better sound quality

- To listen with the headphones:  
Connect the supplied stereo headphones to the  (headphone) jack. The built-in speaker will be automatically disconnected.
- To listen from an external speaker:  
Connect an active or passive speaker (not supplied) to the  (headphone) jack.

### Quickly locating the point you wish to start playback (Easy search)

When “Easy Search” is set to “ON” (page 94) in the menu, you can quickly locate the point at which you wish to start playback by pressing  or  on the control button repeatedly during playback. You can go back approx. 3 seconds by pressing  on the control button once, or advance approx. 10 seconds by pressing  on the control button once. This function is useful for locating a desired point in a long recording.

## Searching forward/backward during playback (Cue/Review)

- To search forward (Cue):  
Press and hold  on the control button during playback and release it at the point you wish to resume playback.
- To search backward (Review):  
Press and hold  on the control button during playback and release it at the point you wish to resume playback.

The IC recorder searches at slow speed with playback sound. This is useful to check one word forward or back. Then, if you press and hold the button, the IC recorder starts to search at higher speed.

### When files are played back to the end of the last file

- When you play back or fast play back to the end of the last file, “FILE END” lights up for approx. 5 seconds.
- When “FILE END” and the operation indicator go off, the IC recorder will stop at the beginning of the last file.
- If you press and hold  on the control button while “FILE END” is lit, the files are played back rapidly, and normal playback will start at the point you release the button.

- If the last file is long and you wish to start playback at a later part of the file, press and hold ►► on the control button to go to the end of the file, and then press ◀◀ on the control button while “FILE END” is lit to go back to the desired point.
- For files other than the last one, go to the beginning of the next file and play backward to the desired point.

## Selecting a recording date from the calendar and playing back

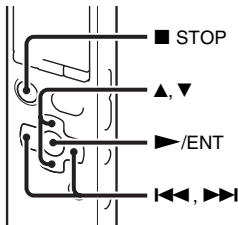

You can play back a file recorded using the IC recorder by searching for it from the calendar.

- 1 Select the  (Display) tab → “Calendar” in the menu, and then press ►/ENT.



The calendar appears after the “Accessing...” animation, and the current date will be selected.

- 2 Press ◀◀ or ►► on the control button to select a date, and then press ►/ENT. The underline is displayed at the date where a recorded file exists.



You can move to the previous week or the following week of the date by pressing ▲ or ▼ on the control button. When you press and hold each button, you can move continuously through the dates or the weeks.

- 3 Press ▲ or ▼ on the control button to select a file, and then press ►/ENT.

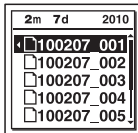

A confirmation message appears, and the file you selected will be played back.

- 4 Press ▲ or ▼ on the control button to select “Enter,” and then press ►/ENT.  
The file will be played back.

- 5 Press ■ STOP to stop playback.

### To cancel the selection of a recording date from the calendar and the accompanying playback

Press ■ STOP before step 4.

#### ■ Notes

- You need to set the clock to select a recording date from the calendar and play back a file (page 16).
- If you specify a date where a recorded file does not exist, the “No File” animation will be displayed. Select a date where a recorded file exists.
- You can search for and play back only the files in the recordable folder that contains

files recorded with the IC recorder. For details, see “Structure of folders and files” (page 104).

## Reducing noise in the playback sound and making the human voice clearer – the noise cut function

### Rear

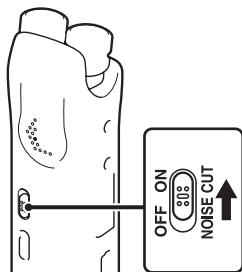

### Front

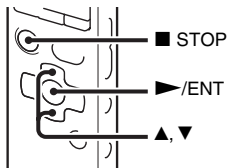

When you set the NOISE CUT switch to “ON,” ambient noise other than the human voice is reduced. A file is played back with clear sound quality because the noise of all frequency bands including a human voice is reduced.

### ■ Notes

- The effect of the noise cut function may be different depending on the condition of the recorded voice.
- When you are using the built-in speaker, the noise cut function does not work.
- When the NOISE CUT switch is set to “ON,” the effect function does not work.

### To set the noise cut level

- 1 Select the ► (Playback) tab → “Noise Cut Level” in the menu, and then press ►/ENT.

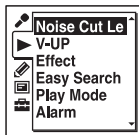

The menu items will be different depending on the model you are using.

- 2 Press ▲ or ▼ on the control button to select “Maximum” or “Medium,” and then press ►/ENT.

“Noise Cut Level” is set to “Maximum” when you purchase the IC recorder.

- 3 Press ■ STOP to exit the menu mode.

### To cancel the noise cut function

Set the NOISE CUT switch to “OFF.”

## Adjusting the playback sound by amplifying inaudible sound – the digital voice up function

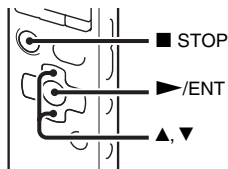

When you set “V-UP” to “Maximum” or “Medium,” the low-level part of a recorded file is amplified, allowing you to hear even low/small voices more easily.

- 1 Select the ► (Playback) tab → “V-UP” in the menu when the IC recorder is in the stop or playback mode, and then press ►/ENT.



The menu items will be different depending on the model you are using.

- 2 Press ▲ or ▼ on the control button to select “Maximum” or “Medium,” and then press ►/ENT.

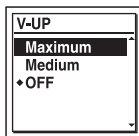

- 3 Press ■ STOP to exit the menu mode.

---

Maximum	Adjusts the digital voice up function more effectively.
---------	---

---

Medium	Adjusts the digital voice up function less finely.
--------	--

---

OFF	Disables the digital voice up function.
-----	---

---

“V-UP” is set to “OFF” when you purchase the IC recorder.

## To cancel the digital voice up function

Set “V-UP” to “OFF” in step 2.

## Adjusting the playback speed and tones – the DPC (Digital Pitch Control) function, key control

### Rear

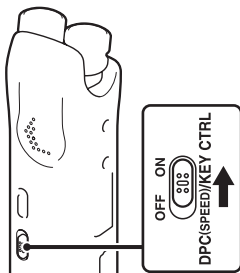

### Front

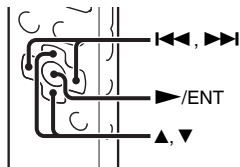

You can adjust the playback speed in a range from 0.25 times to 3.00 times. The file is played back in natural tones by means of a digital processing function. Moreover, you can adjust the playback sounds in semitones higher or lower, each in 6 steps.

This is useful for practicing songs to recorded accompaniment.

- 1 Slide the DPC(SPEED)/KEY CTRL switch to "ON."
- 2 During playback, press ▲ or ▼ on the control button to enter the setting mode.
- 3 Press ◀◀ or ▶▶ on the control button to adjust the playback speed.

◀◀: Decreases the speed by 0.05 times each time this button is pressed (from  $\times 0.25$  to  $\times 1.00$ ).

▶▶: Increases the speed by 0.10 times each time this button is pressed (from  $\times 1.00$  to  $\times 3.00$ ).

When you press and hold each button, you can change the speed continuously.

The playback speed is set to " $\times 0.70$ " when you purchase the IC recorder.

**4** Press ▲ or ▼ on the control button to adjust the playback tone.

▲: Adjusts the sounds by a half-tone higher each time this button is pressed (from #1 to #6).

▼: Adjusts the sound by a half-tone lower each time this button is pressed (from **♭**1 to **♭**6).

The playback tone is set to “0” when you purchase the IC recorder.

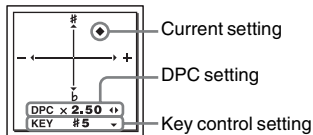

**5** Press ►/ENT to exit the setting mode.

## To resume normal playback speed and sounds

Slide the DPC(SPEED)/KEY CTRL switch to “OFF.”

### Note

When the playback speed is in a range from 2.10 times to 3.00 times, the noise cut function (page 60) and the effect function do not work.

## Selecting the sound effect

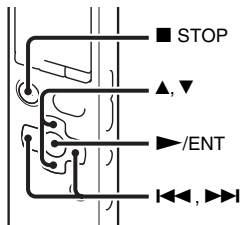

You can set the effect you want for the playback in the menu.

**1** Select the ► (Playback) tab → “Effect” in the menu when the IC recorder is in the stop or playback mode, and then press ►/ENT.



The menu items will be different depending on the model you are using.

- 2** Press ▲ or ▼ on the control button to select effect you want for the playback, and then press ►/ENT.



- 3** Press ■ STOP to exit the menu mode.

Pop	Stresses middle ranges, ideal for vocals.
Rock	Emphasizes high and low ranges for a powerful sound.
Jazz	Emphasizes high ranges for lively sound.
Bass1	Emphasizes the bass sound.
Bass2	Emphasizes the bass sound even more.
Custom	You can design your own custom sound level for 5 bands of EQ and CLEAR BASS.
OFF	Disables the effect function.

"Effect" is set to "OFF" when you purchase the IC recorder.

## To set your favorite sound level

- 1** Set "Effect" to "Custom" in step 2, and then press ►/ENT.

The custom setting window will be displayed.

- 2** When you adjust the sound level for the 0.4 kHz, 1.0 kHz, 2.5 kHz, 6.3 kHz, and 16 kHz bands, press ◀◀ or ▶▶ on the control button to move to the band to the left or right, and then press ▲ or ▼ on the control button.

The setting can be adjusted in 7 steps from -3 to +3.

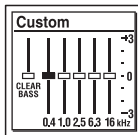

- 3** When you adjust the sound level for "CLEAR BASS," press ◀◀ on the control button to move to "CLEAR BASS," and then press ▲ or ▼ on the control button.

The setting can be adjusted in 4 steps from 0 to +3.

- 4** Press ►/ENT.

5 Press ■ STOP to exit the menu mode.

### ■ Notes

- When you are using the built-in speaker, this setting is invalid.
- When the NOISE CUT switch is set to “ON,” the effect function does not work.

## Selecting the playback mode

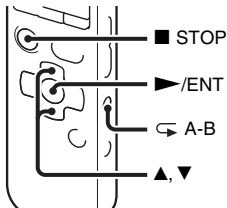

You can select the playback mode in the menu.

1 Select the ► (Playback) tab → “Play Mode” in the menu when the IC recorder is in the stop or playback mode, and then press ►/ENT.







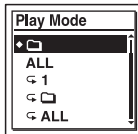

The menu items will be different depending on the model you are using.

2 Press ▲ or ▼ on the control button to select “1,” “□,” “ALL,” “◀ 1,” “◀ □,” or “◀ ALL,” and then press ►/ENT.







3 Press ■ STOP to exit the menu mode.

1	A file is played back.
	Files in one folder are played back continuously.
ALL	All the files are played back continuously.
 1	One file is played back repeatedly.
 	Files in one folder are played back repeatedly.
 ALL	All the files are played back repeatedly.

“Play Mode” is set to “” when you purchase the IC recorder.

## To play back a specified section repeatedly – A-B repeat

- 1 During playback, press  (repeat) A-B to specify the starting point A.  
“A-B B?” is displayed.
- 2 Press  (repeat) A-B again to specify the finishing point B.  
“ A-B” is displayed and the specified section is played back repeatedly.

To resume normal playback:  
Press /ENT.

To stop A-B repeat playback:  
Press  STOP.

To change the segment specified for A-B repeat playback:  
During A-B repeat playback, press  (repeat) A-B again to specify a new starting point A. Then specify a new finishing point B, as in step 2.

### Note

You cannot set the point A and B near the beginning of a file or the end of a file, and around track mark.

# Playing Back a File at a Desired Time with an Alarm

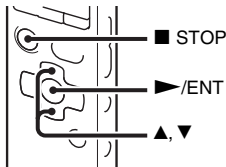

You can sound an alarm and start playback of a selected file at a desired time.

You can have a file played back on a specified date, once every week, or at the same time every day.

You can set a maximum of 30 alarms.

**1** Select the file you want to play back with an alarm.

**2** Enter the alarm setting mode.

- ① Select the ► (Playback) tab → “Alarm” in the menu when the IC recorder is in the stop mode, and then press ►/ENT.



The menu items will be different depending on the model you are using.

- ② Press ▲ or ▼ on the control button to select “New,” and then press ►/ENT.



**3** Set the alarm date and time.

- ① Press ▲ or ▼ on the control button to select “Date,” a day of the week, or “Daily,” and then press ►/ENT.
- ② **When you select “Date”:**  
Set the year, month, day, hour, and minute in sequence, as described in

“Step 4: Setting the Clock” on page 16.

**When you select a day of the week or “Daily”:**

Press ▲ or ▼ on the control button to set the hour, and then press ►/ENT, press ▲ or ▼ on the control button to set the minute, and then press ►/ENT.

- 4** Press ▲ or ▼ on the control button to select a favorite alarm pattern, and then press ►/ENT.



“Executing...,” then your settings are displayed.

- 5** Press ■ STOP to exit the menu mode. The setting process is finished and “(●)” (alarm indicator) appears in the display window.

### To change the alarm setting

- 1** Select the ► (Playback) tab → “Alarm” → “List” in the menu, and then press ►/ENT.

The alarm list is displayed.

- 2** Press ▲ or ▼ on the control button to select the item you want to change, then press ►/ENT.

- 3** Press ▲ or ▼ on the control button to select “Edit,” then press ►/ENT. The file you selected will be played back.

- 4** Select “Date,” a day of the week, or “Daily,” then press ►/ENT.

- 5** Set the date and time and press ►/ENT.

- 6** Select an alarm pattern, and then press ►/ENT. “Executing...,” then your settings are displayed.

- 7** Press ■ STOP to exit the menu mode.

### To cancel the alarm setting

Follow steps 1 and 2 of “To change the alarm setting.” In step 3, select “Cancel” and press ►/ENT. “Cancel Alarm?” is displayed. Press ▲ or ▼ on the control button to select “Execute,” then press ►/ENT. The alarm will be canceled and the

alarm indicator will disappear from the display window.

## **When the set date and time comes**

At the set time, “ALARM” is displayed in the display window and the alarm and the selected file will be played back using the selected alarm pattern.

When the playback ends, the IC recorder will stop automatically. (When the alarm pattern is set to “Beep&Play” or “Play,” the IC recorder will stop at the beginning of the selected file.)

## **To stop the alarm playback**

Press any button other than VOLUME  $-/+$  while the alarm sound is heard. If the HOLD function is activated, you can stop the alarm playback by pressing any button.

### **■ Notes**

- You can set only one alarm each one file.
- When the clock has not been set or no files are recorded, you cannot set the alarm.
- The alarm sounds even if you set “Beep” to “OFF” in the menu (page 100).
- If the alarm time comes while you are updating data, the alarm will be canceled automatically.
- If more than one alarm time comes, only the first file will be played back with an alarm.

- If you divide a file you have set an alarm for, the alarm setting remains on only the first part of the divided file.
- If you erase a file in which you have set an alarm, that alarm will be also canceled.
- You cannot set alarm in podcast files.
- You cannot set an alarm in the files stored on a memory card.

# Playback via Other Devices

## Recording with other equipment

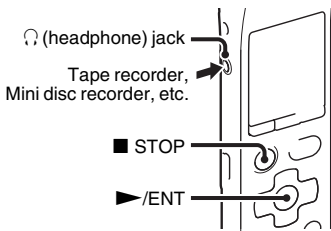

You can record the sound of the IC recorder with other equipment.

Before you start recording, we recommend you make a trial recording first.

- 1 Connect the (headphone) jack of the IC recorder to the external input terminal of other equipment using an audio connecting cable (page 126).
- 2 Press >/ENT to start playback and at the same time set the connected equipment to the recording mode.

A file from the IC recorder will be recorded on the equipment connected.

- 3 Press ■ STOP on the IC recorder and the connected equipment at the same time to stop recording.



### Tip

If the volume of the recorded sound is not strong enough, adjust the playback sound of the IC recorder (page 26).

# Arranging Files in a Folder

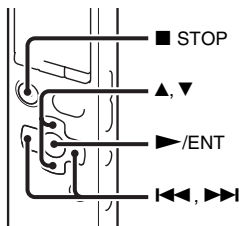





## Moving a file to a different folder





- 1 Select the file you want to move.
- 2 Select the  (Edit) tab → “Move File” in the menu when the IC recorder is in the stop or playback mode, and then press /ENT.



The file to be moved will be played back.

- 3 Press  on the control button, press  or  on the control button to select the  (Voice) tab or the  (Music) tab, and then press .



- 4 Press  or  on the control button to select the folder that you want to move the file into, and then press /ENT.

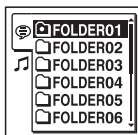

The “Moving File...” animation is displayed and the file is moved to the last position in the destination folder.

When you move a file to another folder, the original file in the previous folder will be erased.

- 5 Press  STOP to exit the menu mode.

## To cancel moving the file

Press ■ STOP before step 4.

### ■ Notes

- You cannot move podcast files.
- You cannot move protected files (page 84).
- You cannot move files to the other memory media.

## Copying a file to the other memory media

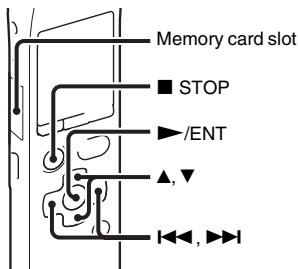



You can copy files between the built-in memory and a memory card, which is useful in saving a backup. Before starting the operation, insert a memory card to be used for copying into the memory card slot.

- 1 Select the file you want to copy.  
When you want to copy a file from a memory card to the built-in memory, set the source memory media to “Memory Card” (page 49).
- 2 Select the  (Edit) tab → “File Copy” in the menu, and then press ►/ENT.



The “Copy to Memory Card Select Folder” or the “Copy to Built-In Memory Select Folder” animation appears and the folder selection window is displayed.

- 3 Press ◀◀ on the control button, press ▲ or ▼ on the control button to select the  (Voice) tab or the  (Music) tab, and then press ▶▶.



- 4 Press ▲ or ▼ on the control button to select the folder that you want to copy the file into, and then press ►/ENT.

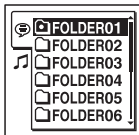

The “Copying...” animation appears and the file is copied as the last file in the destination folder. A file will be copied with the identical file name.

- 5 Press ■ STOP to exit the menu mode.

### To cancel the copy operation

Press ■ STOP before step 4.

### To cancel the copy operation during copying

While the “Copying...” animation is displayed in step 4, press ■ STOP.

### ■ Notes

- Before starting to copy the target file, make sure to check the battery indicator. If the batteries are weak, you may not be able to copy files.
- If the remaining memory capacity of the destination memory media is insufficient, you may not be able to copy files.

- You cannot copy the podcast files.
- Do not remove or insert a memory card, or turn off the IC recorder while copying. Files may be damaged.

## Erasing all files in a folder

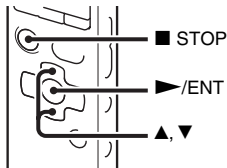

### ■ Note

If the selected folder contains a protected file (page 84), you cannot erase the protected file in that folder.

- 1 Select the folder containing the files you want to erase when the IC recorder is in the stop mode.

- 2** Select the  (Edit) tab → “Erase All” in the menu, and then press **▶/ENT**.



“Erase All Files in the Folder?” will be displayed.

- 3** Press **▲** or **▼** on the control button to select “Execute,” and then press **▶/ENT**.  
The “Erasing...” animation appears in the display window and all files in the selected folder will be erased.

- 4** Press **■** STOP to exit the menu mode.

## To cancel erasing

Select “Cancel” in step 3, and then press **▶/ENT**.

# Using a Track Mark

## Adding a track mark

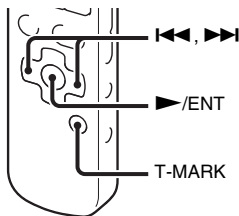

You can add a track mark at a point at which you would like to divide a file later or locate during playback. You can add a maximum of 98 track marks to each file.

During recording, playing back, or pausing, press T-MARK at the position you want to add a track mark.





The  (Track mark) indicator flashes three times, and a track mark is added.



## Notes



- You can add a track mark only to files recorded using the IC recorder. However, when you edit files using the supplied Sound Organizer software, adding a track mark to the files may not be possible.
- You cannot add a track mark at a point within 0.5 seconds from another track mark.
- You cannot add a track mark at the very beginning or at the very end of the file.
- If there are already 98 track marks in a file, you cannot add any more track marks.
- When a track mark is added during playback, the playback stops.

## Locating a track mark and starting playback at the track mark

Press  or  on the control button in the stop mode. When the  (Track mark) indicator flashes once, press /ENT.

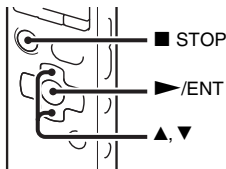

## Erasing a track mark



- 1 Stop at a position after the track mark you would like to erase.
- 2 Select the  (Edit) tab → “Erase Track Mark” in the menu, and then press  /ENT.



“Erase Track Mark?” will be displayed.

- 3 Press  or  on the control button to select “Execute,” and then press  /ENT.

The “Erasing...” animation appears in the display window and the selected track mark will be erased.

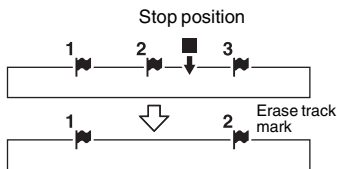

The track mark just before the stop position will be erased.

- 4 Press  to exit the menu mode.

### To cancel erasing

Select “Cancel” in step 3, and then press  /ENT.

## Erasing all the track marks in the selected file at one time

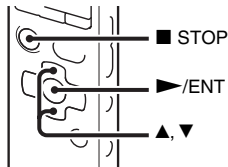

- 1 Select a file from which you want to erase the track marks.
- 2 Select the  (Edit) tab → “Erase All Track Marks” in the menu, and then press **▶/ENT**.



“Erase All Track Marks?” will be displayed.

- 3 Press **▲** or **▼** on the control button to select “Execute,” and then press **▶/ENT**.  
The “Erasing...” animation appears in the display window and all the track marks will be erased at one time.

- 4 Press **■ STOP** to exit the menu mode.

### To cancel erasing

Select “Cancel” in step 3, and then press **▶/ENT**.

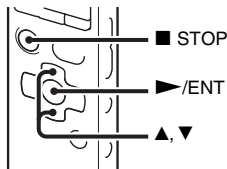

# Dividing a File

## Dividing a file at the current position







You can divide a file in the stop mode, so that the file is divided into two parts and a new file number is added to the newer part of the divided file. By dividing a file, you can easily find the point from which you want to play back when you make a long recording such as at a meeting. You can divide a file until the total number of files in the folder reaches the maximum number allowed.

- 1 Stop the file at the position where you want to divide a file.

- 2 Select the  (Edit) tab → “Divide Current Current Position” in the menu, and then press /ENT.



A period of approximately 4 seconds from the dividing point will be played back repeatedly.

- 3 Press  or  on the control button to adjust the position to be divided, if you wish.  
: Moves the position backward.  
: Moves the position forward.

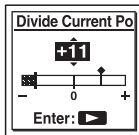

You can adjust the position to be divided by approximately 0.3 seconds in a period

of approximately 6 seconds each, both before and after the current position.

**4** Press ►/ENT.

“Divide?” will be displayed.

**5** Press ▲ or ▼ on the control button to select “Execute,” and then press ►/ENT.

The “Dividing...” animation appears, and the divided files will be suffixed with a sequential number (“\_1” for the original file, and “\_2” for the new file).

File 1	File 2		File 3
	⏏	▲	
	A file is divided.		
File 1	File 2_1	File 2_2	File 3

A suffix made up of a sequential number is added to each of the divided files.

**6** Press ■ STOP to exit the menu mode.

#### ■ Notes

- You need a certain amount of free space in the memory media to divide a file.
- When you divide a file with a title and artist name, the newer part has the same title, and artist name.
- You cannot divide files other than those recorded using the IC recorder (e.g., a file

transferred from a computer). Moreover, when you edit files using the supplied Sound Organizer software, dividing files may not be possible.

- Once a file is divided, you cannot return it to the original status again.
- If you divide a file at the position within 0.5 seconds from a track mark, the track mark will be erased.
- Because of the system limitations, you cannot divide a file at the very beginning or at the very end of the file.

### To cancel dividing

Select “Cancel” in step 5, and then press ►/ENT.

## Dividing a file at all the track mark positions

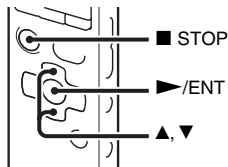

**1** Select the file you want to divide.

- 2 Select the  (Edit) tab → “Divide All Track Marks” in the menu when the IC recorder is in the stop mode, and then press **▶/ENT**.



“Divide All Track Marks?” will be displayed.

- 3 Press **▲** or **▼** on the control button to select “Execute,” and then press **▶/ENT**.

The “Dividing...” animation appears, and the file is divided at all the track mark positions. All the existing track marks in the files will be erased.

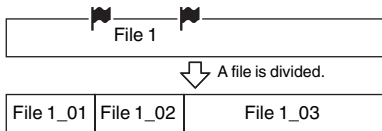

A suffix made up of a sequential number is added each of the divided files.

- 4 Press **■ STOP** to exit the menu mode.

## To cancel dividing

Select “Cancel” in step 3, and then press **▶/ENT**.

### Tip

To cancel division during the operation at all the remaining track marks, press **■ STOP**. The files that have been divided before the cancellation remain divided.

### Notes

- You need a certain amount of free space in the memory media to divide a file.
- When you divide a file with a title and artist name, the newer part has the same title, and artist name.
- You cannot divide files other than those recorded using the IC recorder (e.g., a file transferred from a computer). Moreover, when you edit files using the supplied Sound Organizer software, dividing files may not be possible.
- Once a file is divided, you cannot return it to the original status again.

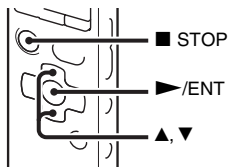

# Changing a Folder Name





You can change the folder name of folders that can be used to store files recorded using the IC recorder.

You can choose a new folder name from the 16 templates.

**1** Select the folder for which you want to change the name from the  (Voice) tab of the folder list.

**2** Select the  (Edit) tab → “Change Folder Name” in the menu when the IC recorder is in the stop mode, and then press /ENT.



**3** Press  or  on the control button to select a favorite folder name, and then press /ENT.

You can choose a new folder name from the 16 templates below.

Conference, Meeting, Lecture, Class, Music, Singing, Interview, Language Lesson, Travel, Outdoors, Message, Schedule, Shopping List, To Do, Voice Notes, FOLDER

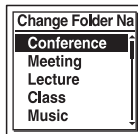

“Executing...” appears in the display window and the folder name will be changed.

**4** Press  STOP to exit the menu mode.

## Tips

- You can specify the same folder name up to 10 times. When you specify a folder name that already exists, a suffix made up of a sequential number (2 to 10) is added to the name of the new folder.

- When you choose “FOLDER” from the templates, a suffix made up of a sequential number (01 to 10) is added to each of the folder names.



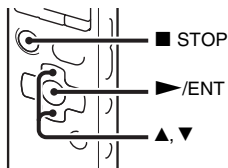

#### **Note**

You cannot change a folder name in a tab used for playback only, such as the 🎵 (Music) tab or the 🎧 (Podcast) tab.

# Protecting a File





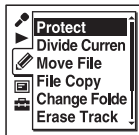

To prevent a file from being accidentally erased or edited, you can protect an important file. A protected file is marked with the  (protect) indicator and is regarded as a read-only file you cannot erase or edit.

- 1 Display the file which you want to protect from the  (Voice) tab or the  (Music) tab.
- 2 Select the  (Edit) tab → “Protect” in the menu when the IC recorder is in the stop mode, and then press /ENT.



“Set Protection?” will be displayed.

- 3 Press  or  on the control button to select “Execute,” and then press /ENT.

The file is protected. A protected file is marked with the  (protect) indicator.

- 4 Press  STOP to exit the menu mode.

## To release protection

Select the protected file, and then proceed with steps 2 through 4. In this case, “Erase Protection?” will be displayed in step 2.

### Note

You cannot set protection to the files in the  (Podcast) tab.

# Making Settings for the Menu

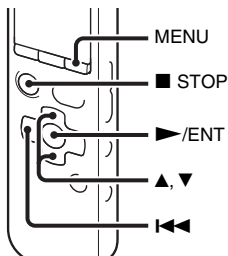

- 1 Press MENU to enter the menu mode.  
The menu mode window will be displayed.



- 2 Press **◀◀** on the control button, press **▲** or **▼** on the control button to select the **🔍** (Recording) tab, the **▶** (Playback) tab, the **✎** (Edit) tab, the **📺** (Display) tab or the **📡** (IC recorder setting) tab, and then press **▶/ENT**.

- 3 Press **▲** or **▼** on the control button to select the menu item for which you want to make setting, and then press **▶/ENT**.

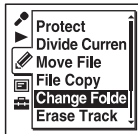

- 4 Press **▲** or **▼** on the control button to select the setting that you want to set, and then press **▶/ENT**.
- 5 Press **■ STOP** to exit the menu mode.

### Note

If you do not press any button for 60 seconds, the menu mode is automatically canceled and the window will return to the normal display.



### To return to the previous window



Press **◀◀** on the control button during menu mode.







### To exit the menu mode

Press **■ STOP** or **MENU**.







# Menu Settings

Tabs	Menu items	Operation mode (○: the setting can be made / —: the setting cannot be made)		
		Stop mode	Playback mode	Recording mode
		 (Recording)	Scene Edit	○
	REC Mode	○	—	—
	REC Level	○	—	○
	LCF(Low Cut)	○	—	○
	LIMITER	○	—	○
	Add/Overwrite	○	—	—
	PRE REC	○	—	—
	Cross-Memory REC	○	—	—
	VOR	○	—	○
	SYNC REC	○	—	—
	Select Input	○	—	○
 (Playback)	Noise Cut Level	○	○	—
	V-UP	○	○	—
	Effect	○	○	—
	Easy Search	○	○	—
	Play Mode	○	○	—
	Alarm	○	—	—

Tabs	Menu items	Operation mode (○: the setting can be made / —: the setting cannot be made)		
		Stop mode	Playback mode	Recording mode
 (Edit)	Protect	○	—	—
	Divide Current Position	○	—	—
	Move File	○	○	—
	File Copy	○	—	—
	Change Folder Name	○	—	—
	Erase Track Mark	○	—	—
	Erase All Track Marks	○	—	—
	Divide All Track Marks	○	—	—
	Erase All	○	—	—
 (Display)	Calendar	○	—	—
	Display	○	○	○
	LED	○	—	—
	Backlight	○	—	—
 (IC recorder setting)	Select Memory	○	—	—
	Language	○	—	—
	Date&Time	○	—	—
	Time Display	○	—	—
	Beep	○	—	—
	USB Charge	○	—	—
	Auto Power Off	○	—	—
Format	○	—	—	



Tabs	Menu items	Settings (*: Initial setting)	See page
 (Recording)	Scene Edit	<p>Edits the settings of the various recording menu items which are pre-set in the “Scene Select” menu. You can choose a scene item as follows:  (Meeting),  (Voice Notes),  (Interview),  (Music),  (My Scene)</p> <p>Edit from Current Setting:            Changes the settings that is pre-set in the menu.</p> <p>Set Default Value:            Changes the settings to the default settings.                Execute: Changes the settings to the default settings and completes the process.                Cancel: Completes the process without changing the settings.</p> <p>Edit:            Changes the settings from the settings in the selected scene item.</p> <p> <b>Tip</b>            You can edit the following menu items: “REC Mode” (page 89), “REC Level” (page 90), “LCF(Low Cut)” (page 90), “LIMITER” (page 91), “VOR” (page 45), “SYNC REC” (page 54), “Select Input” (page 52, 53).            When you select “Edit Complete,” the process will be completed.</p>	36

Tabs	Menu items	Settings (*: Initial setting)	See page
 (Recording)	REC Mode	Sets the recording mode. LPCM 44.1kHz/16bit: LPCM (not compressed) in stereo high-quality recording mode MP3 320kbps*: MP3 (compressed) in stereo high-quality recording mode MP3 192kbps: MP3 (compressed) in stereo standard-quality recording mode MP3 128kbps: MP3 (compressed) in long play stereo recording mode MP3 48kbps(MONO): MP3 (compressed) in monaural standard recording mode MP3 8kbps(MONO): MP3 (compressed) in long play monaural recording mode	–

Tabs	Menu items	Settings (*: Initial setting)	See page
 (Recording)	REC Level	Sets the microphone sensitivity. High  : To record a sound far away from the IC recorder or a low sound, such as recording in a spacious room. Medium  *: To record a sound relatively-close to the IC recorder, such as recording in a meeting space. Low  : To record dictation with a microphone in front of your mouth, a sound near the IC recorder, or a loud sound. High(Music)  : To record more natural acoustic sound, as well as preventing sound distortion. Low(Music)  : To record a loud sound, such as band practice. Manual <b>MAN</b> : During manual recording, you can adjust the recording level manually.	-
	LCF(Low Cut)	Sets the LCF (Low Cut Filter) function to cut a low frequency to reduce the roaring noise from wind; therefore you can record a file more clearly. ON: The LCF function is activated. OFF*: The LCF function is canceled.	-

Tabs	Menu items	Settings (*: Initial setting)	See page
 (Recording)	<b>LIMITER</b>	Sets the input level automatically to prevent the sound distortion that occurs when a sound that is too loud is input. <b>ON*</b> : The LIMITER function is activated. <b>OFF</b> : The LIMITER function is canceled.	–
<p><b>Note</b></p> <p>When “REC Level” is set to “Manual <b>MAN</b>,” this setting is effective.</p>			
	<b>Add/Overwrite</b>	Allows you to add a recording to a previously recorded file or an overwrite recording during playback. <b>Add</b> : You can add a recording. <b>Overwrite</b> : You can overwrite a recording. <b>OFF*</b> : You cannot add or overwrite a recording.	40, 42
	<b>PRE REC</b>	Allows you to record sound sources for a maximum of 5 seconds prior to the point when the recording is started. Sounds for 5 seconds are buffered in the memory. <b>ON</b> : The pre-recording function is activated. <b>OFF*</b> : The pre-recording function is canceled.	43



Tabs	Menu items	Settings (*: Initial setting)	See page
 (Recording)	<b>Cross-Memory REC</b>	<p>When the memory media currently selected (page 49) becomes full during recording, the IC recorder automatically switches its destination to the other memory media and continues recording. The new recording is stored as another file.</p> <p>ON: The cross-memory function is activated.</p> <p>OFF*: The cross-memory function is disabled. Recording stops when the memory media currently being selected becomes full.</p>	50
	<b>VOR</b>	<p>Sets the VOR (Voice Operated Recording) function.</p> <p>ON: Recording starts when the IC recorder detects sound and pauses when no sound is heard, eliminating recording during soundless periods. The VOR function is activated when ● REC/PAUSE is pressed.</p> <p>OFF*: The VOR function does not work.</p>	45
	<b>SYNC REC</b>	<p>When set to “ON,” the IC recorder enters the recording pause mode when no sound is detected for more than 2 seconds, and the IC recorder starts recording again as a new file when any sound is detected.</p> <p>ON: The synchronized recording function is activated.</p> <p>OFF*: The synchronized recording function is canceled.</p>	54



<b>Tabs</b>	<b>Menu items</b>	<b>Settings (*: Initial setting)</b>	<b>See page</b>
 <b>(Recording)</b>	<b>Select Input</b>	<p>Selects the external input to be recorded that is connected to the  (microphone) jack.</p> <p><b>MIC IN*:</b> Select when you record files using an external microphone.</p> <p><b>Audio IN:</b> Select when you record using other equipment.</p>	52, 53
 <b>(Playback)</b>	<b>Noise Cut Level</b>	<p>Sets the noise cut level to use when the IC recorder play a file back which is recorded with noise cut function (page 60).</p> <p><b>Maximum*:</b> The noise cut level will be more intense.</p> <p><b>Medium:</b> The noise cut level will be weakened. Select when you cannot catch the sound easily by setting “Noise Cut Level” to “Maximum.”</p>	61
	<b>V-UP</b>	<p>A low-level portion of a recorded file can be amplified, allowing you to hear even low/small voices more easily.</p> <p><b>Maximum:</b> Adjusts the digital voice up function more effectively.</p> <p><b>Medium:</b> Adjusts the digital voice up function less finely.</p> <p><b>OFF*:</b> Disables the digital voice up function.</p>	61



Tabs	Menu items	Settings (*: Initial setting)	See page
▶ (Playback)	Effect	<p>Sets the effect you want for the playback in the menu.</p> <p>64</p> <p>Pop: Stresses middle ranges, ideal for vocals.</p> <p>Rock: Emphasizes high and low ranges for a powerful sound.</p> <p>Jazz: Emphasizes high ranges for lively sound.</p> <p>Bass1: The bass sound is emphasized.</p> <p>Bass2: The bass sound is emphasized even more.</p> <p>Custom: You can design your own custom sound level for 5 bands of EQ (0.4 kHz, 1.0 kHz, 2.5 kHz, 6.3 kHz and 16 kHz) in 7 steps (-3 to +3) and CLEAR BASS in 4 steps (0 to +3).</p> <p>OFF*: The effect function does not work.</p>	
<p><b>Note</b></p> <p>When playing back files using the built-in speaker or when the NOISE CUT switch is set to “ON” (page 60), the effect function does not work.</p>			
	Easy Search	<p>Sets the easy search function.</p> <p>58</p> <p>ON: You can go forward for about 10 seconds by pressing ▶▶ on the control button and go back for about 3 seconds by pressing ◀◀ on the control button. This function is useful when attempting to locate desired point in a long recording.</p> <p>OFF*: The easy search function does not work. When you press ▶▶ or ◀◀ on the control button, a file will be moved forward or backward.</p>	

Tabs	Menu items	Settings (*: Initial setting)	See page
▶ (Playback)	Play Mode	<p>Sets the playback mode.</p> <p>1: A file is played back.</p> <p>📁*: Files in one folder are played back continuously.</p> <p>ALL: All the files are played back continuously.</p> <p>↶ 1: One file is played back repeatedly.</p> <p>↶ 📁: Files in one folder are played back repeatedly.</p> <p>↶ ALL: All the files are played back repeatedly.</p>	66
	Alarm	<p>Sets the alarm.</p> <p>New: Sets the alarm. To set the alarm, select “New” and set the date, time or day of the week or choose daily for playback, and set the following alarm pattern.</p> <p>Beep&amp;Play: The selected file is played back after the alarm sounds.</p> <p>Beep: Only the alarm sounds.</p> <p>Play: Only the selected file is played back.</p> <p>List: A list of the file numbers, date, or the days of the week in which the alarm has already been set will be displayed.</p> <p>Edit: You can change the selected date or day of the week and time.</p> <p>Cancel: You can cancel the alarm setting on the selected date or on a day of the week.</p>	68

<b>Tabs</b>	<b>Menu items</b>	<b>Settings (*: Initial setting)</b>	<b>See page</b>
 (Edit)	<b>Protect</b>	Protects the selected file to prevent the file from being erased, divided, or being moved. Execute: The selected file will be protected. If you specify a file that has already been protected, cancel the protection. Cancel: Protection or cancel protection is not executed.	84
	<b>Divide Current Position</b>	Divides a file into two. Execute: A file will be divided into two. Cancel: Division is not executed.	79
	<b>Move File</b>	Moves the selected file to the selected folder. Before attempting to move a file, select the file to be moved, and then go to the menu window.	72
	<b>File Copy</b>	Copies the selected file from the built-in memory to the desired folder on a memory card, or from a memory card to the desired folder on the built-in memory. Before attempting to copy a file, select the file to be copied and then go to the menu window.	73
	<b>Change Folder Name</b>	Renames a folder by selecting a template. Conference*, Meeting, Lecture, Class, Music, Singing, Interview, Language Lesson, Travel, Outdoors, Message, Schedule, Shopping List, To Do, Voice Notes, FOLDER	82
	<b>Erase Track Mark</b>	Erases the track mark just before the current position. Execute: The track mark will be erased. Cancel: The track mark will not be erased.	77

<b>Tabs</b>	<b>Menu items</b>	<b>Settings (*: Initial setting)</b>	<b>See page</b>
 <b>(Edit)</b>	<b>Erase All Track Marks</b>	Erases all the track marks of the selected file. Execute: All the track marks will be erased. Cancel: All the track marks will not be erased.	77
	<b>Divide All Track Marks</b>	Divides a file at all the track mark positions. Execute: The track mark division is executed. Cancel: The track mark division is not executed.	80
	<b>Erase All</b>	Erases all files in the selected folder. Press  to return to the folder window before erasing the files and select a folder from which all files are to be erased, and then go to the menu window. Execute: All files in the selected folder will be erased. Cancel: All files will not be erased.	74
 <b>(Display)</b>	<b>Calendar</b>	Switches the display window to a calendar, and plays back a file recorded with the IC recorder by selecting a date from the calendar. Enter: The selected file is played back. Back: The IC recorder does not play the selected file and returns to the calendar view.	59

Tabs	Menu items	Settings (*: Initial setting)	See page
 (Display)	<b>Display</b>	Changes the display mode. Elapsed Time*: Elapsed playback time of one file Remain Time: During stop or playback, the remaining time of one file During recording, the available recording time REC Date: Date recorded REC Time: Time recorded	–
	<b>LED</b>	Turns the operation indicator on or off during operation. ON*: During recording or playback, the operation indicator lights or flashes. OFF: The operation indicator does not light or flash, even during operation.	–
		<b> Note</b>	
		When the IC recorder is connected to a computer, the operation indicator lights or flashes even if “LED” is set to “OFF.”	

Tabs	Menu items	Settings (*: Initial setting)	See page
 (Display)	Backlight	Turns the backlight in the display window on or off. 10 SEC*: The backlight in the display window lights up for approx. 10 seconds. 60 SEC: The backlight in the display window lights up for approx. 60 seconds. Always-ON: The backlight in the display window lights up always. OFF: The backlight in the display window does not light, even during operation.	–
 (IC recorder setting)	Select Memory	Selects the memory media on which you want to store a file, or which contains the file you want to play, edit, or copy. Built-In Memory*: The built-in memory of the IC recorder is selected. Memory Card: The memory card inserted in the memory card slot is selected.	49

**Note**

When you select “Always-ON,” the batteries will be consumed quickly. When you use the IC recorder with batteries, we recommend you select other options than “Always-ON.”

**Note**

When no memory card is currently inserted in the IC recorder, the built-in memory is automatically selected.

<b>Tabs</b>	<b>Menu items</b>	<b>Settings (*: Initial setting)</b>	<b>See page</b>
 <b>(IC recorder setting)</b>	<b>Language</b>	Sets the language to be used for messages, menus, folder names, file names, etc. English*, Español (Spanish), Français (French)	19
	<b>Date&amp;Time</b>	Auto*: When the IC recorder is connected to a computer that is running the Sound Organizer, the clock will be automatically adjusted according to that computer. Manual: Sets the clock by setting year, month, day, hour, and minute in sequence.	16
	<b>Time Display</b>	Sets the clock display. 12-Hour*: 12:00AM = midnight, 12:00PM = noon 24-Hour: 0:00 = midnight, 12:00 = noon	–
	<b>Beep</b>	Sets whether a beep will be heard or not. ON*: A beep will sound to indicate that an operation has been accepted or an error has occurred. OFF: No beep sound will be heard.	–
		<b>Note</b> The alarm sounds even if you set “Beep” to “OFF” in the menu.	

Tabs	Menu items	Settings (*: Initial setting)	See page
 (IC recorder setting)	USB Charge	Sets whether batteries will be charged using a USB connection or not. ON*: The batteries will be charged. OFF: The batteries will not be charged.	–
	<p><b>Note</b></p> <p>If you use a USB AC adaptor (not supplied) to connect the IC recorder to the AC outlet (page 119), you can charge batteries regardless this setting.</p>		
	<b>Auto Power Off</b>	If the IC recorder is on and left for the period you have set, the IC recorder turns off automatically. 5min: The IC recorder will be turned off after approx. 5 minutes. 10min*: The IC recorder will be turned off after approx. 10 minutes. 30min: The IC recorder will be turned off after approx. 30 minutes. 60min: The IC recorder will be turned off after approx. 60 minutes. OFF: The IC recorder will not be turned off automatically.	–

Tabs	Menu items	Settings (*: Initial setting)	See page
 (IC recorder setting)	Format	<p>Formats the memory media currently selected (the built-in memory or the memory card), erasing all the data in the memory and resetting the folder structure to its default status.</p> <p>Execute:            The “Formatting...” animation appears and the memory media will be formatted.</p> <p>Cancel:            The memory media will not be formatted.</p> <p><b>■ Notes</b></p> <ul style="list-style-type: none"> <li>• Use the IC recorder formatting function to format the memory media.              Switch the memory media to the one to be formatted before you start the format operation (page 49).</li> <li>• When you format the memory media, all the data which you have stored on the IC recorder will be erased. Once the memory media has been erased, you cannot retrieve the data that was erased.</li> </ul>	–

# Using the IC Recorder with Your Computer

When the IC recorder is connected to your computer, you can transfer data between them.

**Copying files from the IC recorder to your computer to store them (page 109)**

**Copying music files from your computer to the IC recorder to play them back (page 110)**

**Using the IC recorder as USB memory (page 112)**

You can store image data or text data stored on the computer temporarily in the IC recorder.

**Managing and editing files using the Sound Organizer software (page 113)**

The supplied Sound Organizer software allows you to transfer the files that you have recorded using the IC recorder to your computer to manage and edit them. You can also transfer music files and podcast files stored on your computer to the IC recorder.

**System requirements for your computer**

For details on the system requirements for your computer, see page 114, 124.

**Connecting the IC recorder to your computer**

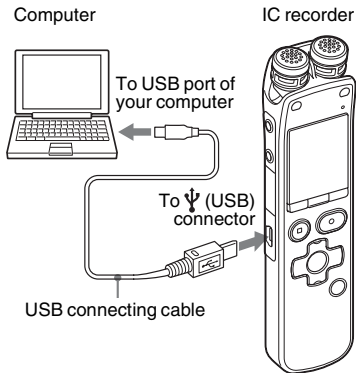

To exchange files between the IC recorder and your computer, connect the IC recorder to your computer.

**1** Connect the  $\Psi$  (USB) connector of the IC recorder with the USB port of your running computer with the supplied USB connecting cable inserted into the connectors securely until each plug stops to the end.

**2** Make sure the IC recorder has been recognized properly.

On a Windows screen; open “My Computer” or “Computer,” and make sure that “IC RECORDER” or “MEMORY CARD” has been recognized.

On a Macintosh screen; make sure that an “IC RECORDER” or “MEMORY CARD” drive is displayed on the desktop.

The IC recorder is recognized by the computer as soon as the connection is made. While the IC recorder is connected to the computer, “Connecting” is displayed in the display window of the IC recorder.

### **■ Notes**

- If you connect more than two USB devices to your computer, normal operation will not be guaranteed.

- Use of this IC recorder with a USB hub or a USB connection support cable other than the supplied cable is not guaranteed.
- A malfunction may occur depending on the USB devices connected at the same time.
- Before connecting the IC recorder to your computer, check that batteries are inserted in the IC recorder.
- It is recommended that you disconnect the IC recorder from the computer when you are not using the IC recorder connected to the computer.

## **Structure of folders and files**

The folders and files are displayed on the computer screen as shown.

On a Windows screen using Explorer, and on a Macintosh screen using Finder, folders and files can be displayed by opening “IC RECORDER” or “MEMORY CARD.”

## Built-in memory

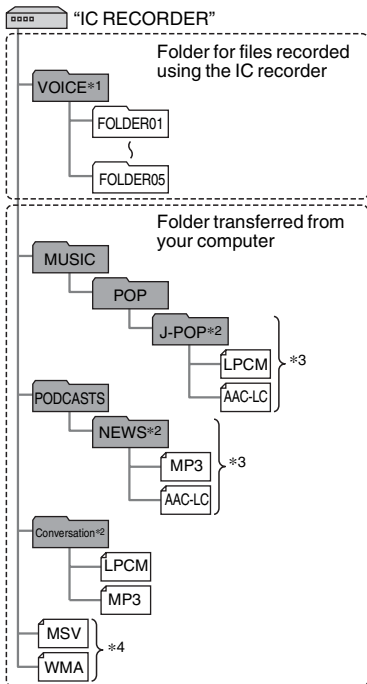

\*1 Even if a file is transferred directly under the VOICE folder, it will not be displayed on the  (Voice) tab of the IC recorder.

When you transfer a file from your computer to the IC recorder, put the file in the folders under the VOICE folder.

\*2 The name of a folder in which music files are stored will be displayed on the IC recorder as it is, so it is convenient if you put an easy-to-remember name on the folder in advance.

Folders shown in the illustration are examples of folder names.

\*3 The IC recorder can recognize up to 8 levels of folders transferred to the IC recorder.

\*4 If you transfer music files separately, they are classified as being in "No Folder."

### Tips

- The title or artist name, etc., registered in the music files, can be displayed on the IC recorder. It is useful if you input the ID3 tag information using the software you use to make the music files on your computer.
- If no title, or artist name has been registered "Unknown" will be displayed in the display window of the IC recorder.

When connecting the IC recorder with your computer after the destination memory media has been set to "Memory Card" (page 49), the structure of folders is different from that when the destination memory media is set to "Built-In Memory."

## Memory Stick Micro™ (M2™)

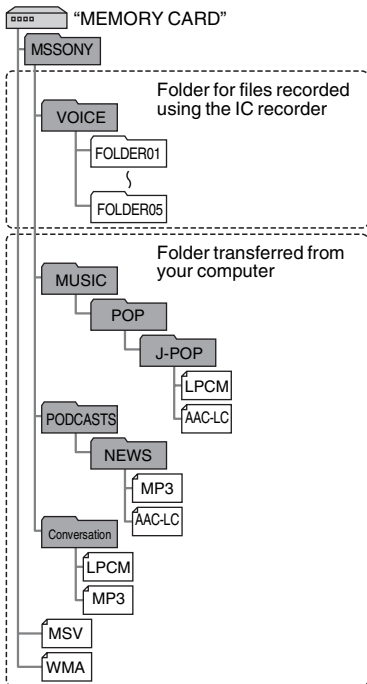

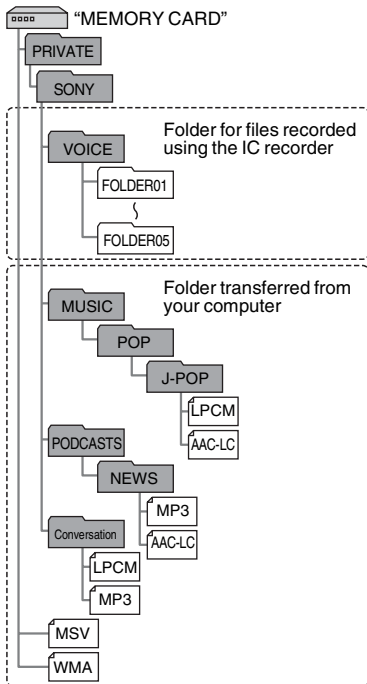

## microSD card



## Structure of folders displayed in the display window of the IC recorder

The display of the structure of the folders seen in the display window of the IC recorder is different from that seen on the display of a computer.

The folder indicators in the display window of the IC recorder are as follows:

- : Folder for files recorded using the IC recorder
- : Folder transferred from a computer (They are displayed when music files have been transferred from a computer.)
- : Folder for podcast files transferred from a computer (These folders are displayed when podcast files have been transferred from a computer.)

### Note

If folders have no files that can be played back using the IC recorder, those folders will not be displayed in the display window of the IC recorder.

## Folders displayed on the (Voice) tab of the IC recorder



Folders for files recorded using the IC recorder (folders under the VOICE folder) will be displayed.

### Note

Even if a file is transferred directly under the VOICE folder, it will not be displayed on the (Voice) tab of the IC recorder.

## Folders displayed on the (Music) tab of the IC recorder



The following folders will be displayed among the folders forwarded from a computer.

- Folders under the MUSIC folder which contains a file (when some folders have multiple levels, all folders will be displayed in parallel.)

- Folders transferred to places other than under the MUSIC folder or the PODCASTS folder
- A folder called “No Folder” (If you transfer music files separately, those files will be displayed under this folder.)

### Folders displayed on the Ⓒ (Podcast) tab of the IC recorder



Folders for podcast files transferred from a computer will be displayed. When you transfer podcast files from your computer to the IC recorder, use the supplied Sound Organizer software.

## Disconnecting the IC recorder from your computer

Follow the procedures below; otherwise, data may be damaged.

- 1 Make sure that the operation indicator of the IC recorder does not light.

- 2 Perform the following operation on your computer.

On a Windows screen, left-click the icon at the bottom of the desktop of the computer.



→ Left-click “Eject IC RECORDER.”

The icon and menu displayed can be different on different operating systems. On a Macintosh screen, drag “IC RECORDER” on the desktop to “Trash” and drop it there.

For details on disconnecting the IC recorder from your computer, refer to the operating instructions supplied with your computer.

- 3 Disconnect the USB connecting cable connected to the IC recorder from the USB port of the computer.

# Copying Files from the IC Recorder to Your Computer

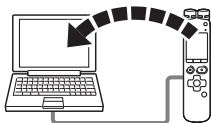

You can copy the files and folders from the IC recorder to your computer to store them.

- 1** Connect the IC recorder to your computer (page 103).
- 2** Copy files or folders you want to transfer to your computer.  
Drag and drop the files or folders you want to copy from “IC RECORDER” or “MEMORY CARD” to the local disk on your computer.

 **To copy a file or folder (Drag and drop)**

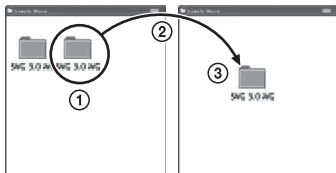

- 1** Click and hold,
- 2** drag,
- 3** and then drop.

- 3** Disconnect the IC recorder from your computer (page 108).

# Copying Music Files from Your Computer to the IC Recorder and Playing Them Back



You can copy music or the other audio files (LPCM(.wav)/MP3(.mp3)/LPEC(.msv)/WMA(.wma)/AAC-LC(.m4a)\*) from your computer to the IC recorder by dragging and dropping them, and you can play them back using the IC recorder.

\* For the file formats that can be played back using the IC recorder, see “Specifications” (page 124).

## Copying a music file from your computer to the IC recorder (drag and drop)

**1** Connect the IC recorder to your computer (page 103).

**2** Copy the folder in which the music files are stored to the IC recorder.





On a Windows screen using Explorer, or on a Macintosh screen using Finder, drag and drop the folder containing the music files onto “IC RECORDER” or “MEMORY CARD.”

The IC recorder can recognize up to 400 folders. You can copy up to 199 files to one folder. Moreover, the IC recorder can recognize up to a total of 4,095 folders and files for one memory media.

**3** Disconnect the IC recorder from your computer (page 108).

## Playing back music files copied from your computer using the IC recorder

**1** Press .

**2** Press  on the control button, press  or  on the control button to select the  (Music) tab, and then press .

- 3 Press ▲ or ▼ on the control button to select the folder (  ) in which music files are stored, and then press ►► on the control button.
- 4 Press ▲ or ▼ on the control button to select the music file you want to play.
- 5 Press ►/ENT to start playback.
- 6 Press ■ STOP to stop playback.

The maximum playback time (files\*), when playing music files using the IC recorder, is as follows.

48 kbps	128 kbps	256 kbps
89 hr. 25 min. (1,341 files)	33 hr. 30 min. (502 files)	16 hr. 45 min. (251 files)

(hr.: hours/min.: minutes)

\* In the case where MP3 files of 4 minutes each are transferred to the IC recorder.

### ■ Notes

- A music file copied from your computer can be played back with the IC recorder. Dividing a file and setting a track mark, however, may not be performed.
- If you have copied music files using your computer, those files may not be copied in order of transfer because of system

limitations. If you copy music files from your computer to the IC recorder one by one, you can display and play back the music files in copied order.

## Display when playing back a music file

Press ▲ or ▼ on the control button to check the music file information during playback.

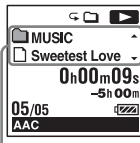

 : Folder name

 : File name

 : Artist name

 : Title

## Using the IC Recorder as USB Memory

When the IC recorder is connected to your computer using a USB connecting cable, image data or text data on the computer, as well as files recorded using the IC recorder can be temporarily stored on the IC recorder.

Your computer must meet the specified system requirements to use the IC recorder as USB memory.

For details on the system requirements, see page 124.

# Using the Supplied Sound Organizer Software

## What you can do using Sound Organizer

Sound Organizer allows you to exchange files with an IC recorder or memory card. The songs imported from music CDs and other media, MP3 and other audio files imported from a computer, and podcasts can also be played and transferred to an IC recorder. Various operations can be performed for imported files, including playback, editing and conversion to MP3 and other formats. You can also burn CDs of the music you like, and send audio files by mail.

## Importing files recorded with an IC recorder

You can import recording files that were recorded with an IC recorder into Sound Organizer. The imported files are saved to the computer.

## Importing songs from a music CD

You can import the songs of a music CD into Sound Organizer. The imported songs are saved to the computer.

## Importing songs on the computer

You can import music and other files saved to the computer into Sound Organizer.

## Subscribing to and updating podcasts

You can subscribe to podcasts in Sound Organizer.

Subscribing to and updating podcasts enables you to download (subscription) and enjoy the latest data from the Internet.

## Playing files

You can play the files imported into Sound Organizer.

## Changing the file information of files

You can change the title name, artist name, and other file information displayed in the file list.

## Dividing files

You can divide one file into multiple files.

## Combining files

You can combine multiple files into one file.

## Deleting files from an IC recorder

You can delete a file saved to an IC recorder.

Use this operation to delete files in the IC recorder when you want to increase the amount of free space in the IC recorder or there are unnecessary files.

## Transferring files to an IC recorder

You can transfer a file from Sound Organizer to an IC recorder or memory card.

You can enjoy transferred music, podcasts, and other content on your IC recorder.

## Burning a music CD

You can select your favorite songs from the songs imported into Sound Organizer and then burn your own original music CD.

## Other convenient uses

- You can start the mail software and send a recording file attached to mail.
- You can use the voice recognition software Dragon NaturallySpeaking\* which is compatible with Sound Organizer to perform voice recognition for a file and convert the voice to text.

\* The application software, Dragon NaturallySpeaking (DVD-ROM) is supplied with some models in some regions only.

## System requirements for your computer

The following shows the system requirements for using Sound Organizer.

### Operating systems

- Windows 7 Ultimate
- Windows 7 Professional
- Windows 7 Home Premium
- Windows 7 Starter (32 bit version)
- Windows Vista Ultimate Service Pack 2 or higher

- Windows Vista Business Service Pack 2 or higher
  - Windows Vista Home Premium Service Pack 2 or higher
  - Windows Vista Home Basic Service Pack 2 or higher
  - Windows XP Media Center Edition 2005 Service Pack 3 or higher
  - Windows XP Media Center Edition 2004 Service Pack 3 or higher
  - Windows XP Professional Service Pack 3 or higher
  - Windows XP Home Edition Service Pack 3 or higher
- Pre-installed.

### ■ Notes

- Operation is not guaranteed if any operating system other than those indicated listed above is used.
- 64 bit versions of Windows XP are not supported.

### IBM PC/AT or compatible

#### • CPU

Windows XP: Pentium III processor of 500 MHz or faster  
 Windows Vista: Pentium III processor of 800 MHz or faster  
 Windows 7: Pentium III processor of 1 GHz or faster

#### • Memory

Windows XP: At least 256 MB  
 Windows Vista: At least 512 MB (In the case of Windows Vista Ultimate/Business/Home Premium, at least 1 GB is recommended.)

Windows 7: At least 1 GB (32 bit version)/At least 2 GB (64 bit version)

#### • Free hard disk space

At least 400 MB is required.  
 Depending on the version of Windows, more than 400 MB may be used.

Also, free space for handling music data is required.

#### • Display settings

Screen resolution: 800 × 600 pixels or higher (1,024 × 768 pixels is recommended)

Screen color: High Color (16 bit) or higher

#### • Sound card

A SoundBlaster compatible card is recommended.

#### • USB port

A compatible USB port is required to use devices and media.

Operation via a USB hub is not guaranteed except for models for which operation has been specifically guaranteed.

## Installing Sound Organizer

Install Sound Organizer on your computer.

### ■ Notes

- When installing Sound Organizer, log in to an account with administrator privileges. Also, if you are using Windows 7 and the [User Account Control] screen appears, confirm the contents of the screen and then click [Yes] ([Continue] in the case of Windows Vista).
- Sound Organizer cannot be started by a user with limited privileges in Windows XP.
- To use the software update function in Windows XP, you must log on to an account with computer administrator privileges.
- The Windows Media Format Runtime module is added by the installer of Sound Organizer. This module is not removed when Sound Organizer is uninstalled. However, it may not be installed if it has been preinstalled.
- The data in the content storage folders is not deleted when Sound Organizer is uninstalled.
- In an installation environment in which multiple operating systems are installed on one computer, do not install Sound Organizer in each of the operating systems. Doing so may result in data inconsistencies.

- 1** Make sure that the IC recorder is not connected, then turn on your computer and start up Windows.
- 2** Insert the supplied CD-ROM into the CD-ROM drive.  
The [Sound Organizer - InstallShield Wizard] menu starts up automatically and the [Welcome to Sound Organizer Installer] window appears.  
If the [Welcome to Sound Organizer Installer] menu does not start up, open Windows Explorer, right-click the CD-ROM drive, double-click [SoundOrganizerInstaller.exe], and then follow the instructions on the screen.
- 3** Make sure that you accept the terms of the license agreement, select [I accept the terms in the license agreement], then click [Next].
- 4** When the [Setup Type] window appears, select [Standard] or [Custom], and then click [Next].  
Follow the instructions on the screen and set the installation settings when you select [Custom].

**5** When the [Ready to Install the Program] window appears, click [Install].  
The installation starts.

**6** When [Sound Organizer has been installed successfully.] window appears, check [Launch Sound Organizer Now], and then click [Finish].

### **Note**

You may need to restart your computer after installing Sound Organizer.

## The Sound Organizer window

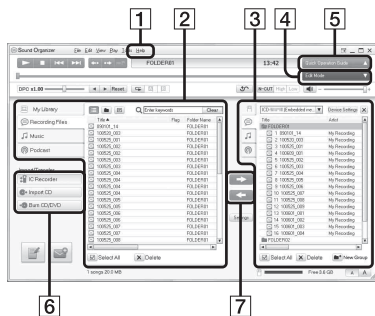

**1** Help

Displays the help of Sound Organizer. For details on each operation, refer to these help files.

**2** The file list of Sound Organizer (My Library)

Displays a list of files included in My Library of Sound Organizer in accordance with the operation.

Recording Files: Displays a list of recording files.

Recording files that were recorded with an IC recorder appear in this library when they are imported.

Music: Displays a list of music files. Songs imported from a music CD appear in this library.

Podcast: Displays a list of podcasts.

**3** The file list of the IC recorder

Displays the files saved to the connected IC recorder or memory card.

**4** Edit Mode button

Displays the edit area so that you can edit a file.

**5** Quick Operation Guide button

Displays the Quick Operation Guide to receive guidance on the basic features of Sound Organizer.

## 6 Sidebar (Import/Transfer)

 IC Recorder: Displays the transfer screen. A list of files on a connected device appears.

 Import CD: Displays the screen for importing music CDs.

 Burn CD/DVD: Displays the screen for burning discs.

## 7 Transfer buttons

 : Transfers the files of Sound Organizer to an IC recorder or memory card.

 : Imports the files of an IC recorder or memory card to My Library of Sound Organizer.

## Using a USB AC Adaptor

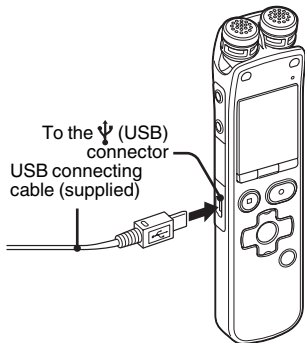

You can charge the rechargeable batteries by connecting the IC recorder to an AC outlet using a USB AC adaptor AC-U501AD (not supplied). You can charge the batteries while you are using the IC recorder, so that it is useful when you want to record for a long time. When you use the IC recorder for the first time, or after you have not used the IC recorder for a certain period of time, charge

the batteries continuously until “**FULL**” is displayed.

It takes about 4 hours to fully charge exhausted batteries.\*

- 1 Connect a USB AC adaptor (not supplied) to an AC outlet.
- 2 Connect the USB AC adaptor to the supplied USB connecting cable.
- 3 Connect the USB connecting cable to the Ψ (USB) connector of the IC recorder. While the batteries are charging, the battery indicator is displayed in an animation.

Now you can use the IC recorder while charging the batteries.

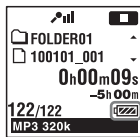

Battery indicator

\* This is an approximation for the time it takes to charge from no remaining battery power to full battery power at room temperature. It varies depending on the remaining power

and the condition of the batteries. It also takes more time if the temperature of the batteries is low, or if the batteries are charged while you are transferring data to the IC recorder.

### **■ Notes**

- While playing back files using the built-in speaker, you cannot charge the batteries.
- You cannot charge LR03 (size AAA) alkaline batteries.

## **Disconnecting the IC recorder from the AC outlet**

Follow the procedures below; otherwise, when the IC recorder contains data files, the files may be damaged or become unplayable.

- 1** If you are recording or playing back a file, press **■ STOP** to put the IC recorder into the stop mode.
- 2** Make sure that the operation indicator of the IC recorder does not light.
- 3** Disconnect the IC recorder from the USB AC adaptor, and then disconnect the USB AC adaptor from the AC outlet.

### **■ Notes**

- During recording (the operation indicator lights or flashes in red) or accessing data (the operation indicator flashes in orange),
  - the IC recorder should not be connected to or disconnected from the USB AC adaptor connected to the AC outlet.
  - the USB AC adaptor connected to the IC recorder should not be connected to or disconnected from the AC outlet.Doing so may damage the data. If the IC recorder is required to process a large amount of data, the start-up window may be displayed for an extended period of time. This is not a malfunction of the IC recorder. Wait until the start-up display disappears from the display window.
- While a USB AC adaptor is being used, the battery indicator does not appear in the display window.

# Precautions

## On power

Operate the unit only on 2.4 V or 3.0 V DC. Use two NH-AAA rechargeable batteries or two LR03 (size AAA) alkaline batteries.

## On safety

Do not operate the unit while driving, cycling or operating any motorized vehicle.

## On handling

- Do not leave the unit in a location near heat sources, or in a place subject to direct sunlight, excessive dust or mechanical shock.
- Should any solid object or liquid fall into the unit, remove the batteries and have the unit checked by qualified personnel before operating it any further.
- Be careful not to allow water to splash on the unit. The unit is not water-proof. In particular, be careful in the following situations.
  - When you have the unit in your pocket and go to the bathroom, etc.  
When you bend down, the unit may drop into the water and may get wet.

- When you use the unit in an environment where the unit is exposed to rain, snow, or humidity.
- In circumstances where you get sweaty. If you touch the unit with wet hands or if you put the unit in the pocket of sweaty clothes, the unit may get wet.
- You may feel pain in your ears if you use the headphones when the ambient air is very dry. This is not because of a malfunction of the headphones, but because of static electricity accumulated in your body. You can reduce static electricity by wearing non-synthetic clothes that prevent the emergence of static electricity.

## On noise

- Noise may be heard when the unit is placed near an AC power source, a fluorescent lamp or a mobile phone during recording or playback.
- Noise may be recorded when an object, such as your finger, etc., rubs or scratches the unit during recording.

## On maintenance

To clean the exterior, use a soft cloth slightly moistened in water. Do not use alcohol, benzine or thinner.

If you have any questions or problems concerning your unit, please consult your nearest Sony dealer.

### Backup recommendations

To avoid potential risk of data loss caused by accidental operation or malfunction of the IC recorder, we recommend that you save a backup copy of your recorded files to a computer, etc.

## On using a memory card

### ■ Notes

- When formatting (initializing) a memory card, make sure to use the IC recorder to format it. Operations of the memory cards formatted with Windows or other devices are not guaranteed.
- If you format a memory card containing recorded data, the recorded data will be deleted. Be careful not to delete important data.
- Do not leave a memory card within the reach of small children. They might accidentally swallow it.
- Do not insert or remove a memory card during recording/playback/formatting. Doing so may cause a malfunction of the IC recorder.
- Do not remove a memory card while the “Accessing...” animation appears in the display window or the indicator is flashing in orange. Doing so may damage the data.
- We do not guarantee the operations of all types of compatible memory cards with the IC recorder.
- For compatible M2™, please refer to the Sony web site (page 124).
- “MagicGate™” is the collective name of content protection technologies developed by Sony. The IC recorder does not support data recording/playback that requires MagicGate™ functions.
- The IC recorder does not support parallel data transfer.
- You cannot use a ROM (read-only-memory) type or write-protected memory card.
- Data may be corrupted in the following cases:
  - When a memory card is removed or the IC recorder is turned off during a read or write operation.
  - When a memory card is used in locations subject to static electricity or electrical noise.
- We assume no responsibility for any loss or damage of recorded data.

- We recommend that you save a backup copy of the important data.
- Do not touch the terminal of a memory card with your hand or a metal object.
- Do not strike, bend or drop a memory card.
- Do not disassemble or modify a memory card.
- Do not expose a memory card to water.
- Do not use a memory card under the following conditions:
  - Locations beyond the required operating conditions, including locations, such as the hot interior of a car parked in the sun and/or in the summer, the outdoors exposed to direct sunlight, or a place near a heater.
  - Humid locations or locations with corrosive substances present.
- When using a memory card, make sure to check the correct insertion direction into the memory card slot.

# Specifications

## System requirements

### To use your computer with the Sound Organizer software

To use your computer with the Sound Organizer software, see “System requirements for your computer” on page 114.

### To use your computer without the Sound Organizer software

To use your computer with the IC recorder without the Sound Organizer software, or to use the IC recorder as a USB mass storage device, your computer must meet the operating system requirements and port environment described below.

### Operating systems:

- Windows 7 Ultimate
- Windows 7 Professional
- Windows 7 Home Premium
- Windows 7 Home Basic
- Windows 7 Starter
- Windows Vista Ultimate Service Pack 2 or higher
- Windows Vista Business Service Pack 2 or higher

- Windows Vista Home Premium Service Pack 2 or higher
  - Windows Vista Home Basic Service Pack 2 or higher
  - Windows XP Media Center Edition 2005 Service Pack 3 or higher
  - Windows XP Media Center Edition 2004 Service Pack 3 or higher
  - Windows XP Media Center Edition Service Pack 3 or higher
  - Windows XP Professional Service Pack 3 or higher
  - Windows XP Home Edition Service Pack 3 or higher
  - Mac OS X (v10.2.8-v10.6)
- Pre-Installed

### Notes

- Operation is not guaranteed if any operating system other than those indicated on the left (Windows 98, Windows 2000 or Linux, etc.) is used.
- 64 bit versions of Windows XP are not supported.
- For the latest version information and compatibility with your operating system, please access the support home page for the IC recorder:  
<http://www.sony.com/recordersupport>

## Hardware environment:

- Sound board: Sound cards compatible with any of the supported Microsoft Windows operating systems
- Port: USB port

### Note

- The following systems are not supported:
  - Operating systems other than the ones indicated on page 124
  - Personally constructed computers or operating systems
  - Upgraded operating systems
  - Multi-boot environment
  - Multi-monitor environment

## Design and specifications

### IC recorder section

#### Capacity (User available capacity)

2 GB equals 2,147,483,648 bytes, a portion of which is used for system management and/or application files.

Available capacity is approximately 1.80 GB (1,932,735,283 bytes).

#### Frequency range

- LPCM 44.1kHz/16bit: 40 Hz - 20,000 Hz
- MP3 320kbps: 40 Hz - 16,000 Hz
- MP3 192kbps: 40 Hz - 16,000 Hz
- MP3 128kbps: 40 Hz - 16,000 Hz
- MP3 48kbps(MONO): 40 Hz - 14,000 Hz
- MP3 8kbps(MONO): 50 Hz - 2,000 Hz

#### Bit rate and sampling frequencies for MP3 files\*1

Bit rate: 32 kbps - 320 kbps, VBR  
 Sampling frequencies:  
 16/22.05/24/32/44.1/48 kHz  
 File extension: .mp3

\*1 The playback of MP3 files recorded using the IC recorder is also supported. Not all encoders are supported.

#### Bit rate and sampling frequencies for WMA files\*2

Bit rate: 32 kbps - 192 kbps, VBR  
 Sampling frequencies: 44.1 kHz  
 File extension: .wma

\*2 WMA Ver. 9 is compatible, however, MBR (Multi Bit Rate), Lossless, Professional, and Voice are not supported.  
 Copyright-protected file cannot be played back.  
 Not all encoders are supported.

#### Bit rate and sampling frequencies for AAC-LC files\*3

Bit rate: 16 kbps - 320 kbps, VBR  
 Sampling frequencies:  
 11.025/12/16/22.05/24/32/44.1/48 kHz  
 File extension: .m4a

\*3 Copyright-protected file cannot be played back.  
 Not all AAC encoders are supported.

## Sampling frequencies and bit for linear PCM files

Sampling frequencies: 22.05/44.1 kHz

Bit: 16 bit

File extension: .wav

## General

### Speaker

Approx. 16 mm (21/32 in.) dia.

### Input/Output

- Microphone jack (minijack, stereo)
  - input for plug in power, minimum input level
  - 1.5 mV
- Headphone jack (minijack, stereo)
  - output for 8 ohms - 300 ohms impedance headphones
- USB connector (mini-B jack)
  - High-Speed USB compatible
- Memory Stick Micro™ (M2™)/microSD memory card slot

### Playback speed control (DPC)

3.00 times - 0.25 times

### Power output

150 mW

### Power requirements

Two NH-AAA rechargeable batteries: 2.4 V DC

Two LR03 (size AAA) alkaline batteries: 3.0 V DC

### Operating temperature

5°C - 35°C (41°F - 95°F)

### Dimensions (w/h/d) (not incl. projecting parts and controls) (JEITA)\*4

Approx. 32.4 mm × 137.8 mm × 16 mm  
(1 1/4 in. × 5 3/8 in. × 5/8 in.)

### Mass (JEITA)\*4

Approx. 68 g (2 3/8 oz) excluding batteries

\*4 Measured value by the standard of JEITA (Japan Electronics and Information Technology Industries Association)

### Supplied accessories

See page 8.

### Optional accessories

Memory Stick Micro™ (M2™) MS-A16GU2, MS-A8GU2, MS-A4GU2, MS-A2GU2  
microSD/microSDHC SR-8A4, SR-4A4, SR-2A1

Active speaker SRS-M50

Electret condenser microphone ECM-CS10, ECM-TL1

Audio connecting cable RK-G136, RK-G139





Rechargeable battery NH-AAA-B2KN

USB AC adaptor AC-U501AD

Design and specifications are subject to change without notice.

## Maximum recording time\*5\*6

The maximum recording time of all the folders is as follows.

REC Mode	Recording scene*7	Built-in memory	Memory card				
		ICD-SX712	2 GB	4 GB	8 GB	16 GB	32 GB
LPCM 44.1kHz/ 16bit	 (Music)	3 hr. 0 min.	3 hr. 0 min.	6 hr. 0 min.	12 hr. 5 min.	24 hr. 15 min.	48 hr. 40 min.
	 (My Scene)						
MP3 320kbps		13 hr. 20 min.	13 hr. 20 min.	26 hr. 45 min.	53 hr. 40 min.	107 hr. 0 min.	214 hr. 0 min.
MP3 192kbps	 (Meeting)	22 hr. 20 min.	22 hr. 20 min.	44 hr. 40 min.	89 hr. 25 min.	178 hr. 0 min.	357 hr. 0 min.
	 (Interview)						
MP3 128kbps	 (Voice Notes)	33 hr. 30 min.	33 hr. 30 min.	67 hr. 5 min.	134 hr. 0 min.	268 hr. 0 min.	536 hr. 0 min.
MP3 48kbps(MONO)		89 hr. 25 min.	89 hr. 25 min.	178 hr. 0 min.	357 hr. 0 min.	715 hr. 0 min.	1,431 hr. 0 min.
MP3 8kbps(MONO)		536 hr. 0 min.	536 hr. 0 min.	1,073 hr. 0 min.	2,147 hr. 0 min.	4,294 hr. 0 min.	8,589 hr. 0 min.

(hr.: hours/min.: minutes)

\*5 When you are going to record continuously for a long time, you may have to replace the batteries with new ones in the midst of recording. For details on the battery life, see the next table.

\*6 The maximum recording time varies if you record files in mixed recording mode.

\*7 Default settings

## Battery life

### When using Sony NH-AAA rechargeable batteries\*1

REC Mode	Recording	Playback through speaker*2	Playback using the headphones
LPCM 44.1kHz/16bit	19 hr.	16 hr.	22 hr.
MP3 320kbps	17 hr.	16 hr.	22 hr.
MP3 192kbps	17 hr.	16 hr.	22 hr.
MP3 128kbps	17 hr.	16 hr.	22 hr.
MP3 48kbps(MONO)	19 hr.	16 hr.	22 hr.
MP3 8kbps(MONO)	19 hr.	16 hr.	22 hr.
Music file (128 kbps/44.1kHz)	–	16 hr.	22 hr.

(hr.: hours)

## When using Sony LR03 (SG) (size AAA) alkaline batteries\*1

REC Mode	Recording	Playback through speaker *2	Playback using the headphones
LPCM 44.1kHz/16bit	25 hr.	21 hr.	30 hr.
MP3 320kbps	22 hr.	21 hr.	30 hr.
MP3 192kbps	22 hr.	21 hr.	30 hr.
MP3 128kbps	22 hr.	21 hr.	30 hr.
MP3 48kbps(MONO)	25 hr.	21 hr.	30 hr.
MP3 8kbps(MONO)	25 hr.	21 hr.	30 hr.
Music file (128 kbps/44.1kHz)	–	21 hr.	30 hr.

(hr.: hours)

\*1 The battery life is measured in testing using methods proprietary to Sony. The battery life may shorten depending on how you operate the IC recorder.

\*2 When playing back music through the internal speaker with the volume level set to 20

# Troubleshooting











Before taking the IC recorder for repair, check the following sections. Should any problem persist after you have made these checks, consult your nearest Sony dealer.





Please note that recorded files may be deleted during service or repair work.

Symptom	Remedy
Noise is heard.	<ul style="list-style-type: none"><li>• An object, such as your finger, etc., accidentally rubbed or scratched the IC recorder during recording so that noise was recorded.</li><li>• The IC recorder was placed near an AC power source, a fluorescent lamp or a mobile phone during recording or playback.</li><li>• The plug of the connected microphone is dirty. Clean the plug.</li><li>• The plug of the connected headphones is dirty. Clean the plug.</li><li>• Noise may be heard during recording pause of an MP3 file, VOR recording, or synchronized recording.</li></ul>
You cannot charge the batteries by connecting the IC recorder to your computer.	<ul style="list-style-type: none"><li>• When you connect the IC recorder to a computer which is not running, the batteries will not be charged.</li><li>• Even if the computer is on, and the computer is in a mode of reduced operation (standby or sleep), you cannot charge the batteries.</li><li>• “USB Charge” is set to “OFF” in the menu. To charge the batteries using your computer, set it to “ON” (page 101).</li><li>• Disconnect the IC recorder from your computer and reconnect it.</li><li>• Operation is not guaranteed if you use any system requirements other than those described on page 124.</li></ul>

Symptom	Remedy
The charging indicator is not displayed or disappears in the middle of charging.	<ul style="list-style-type: none"> <li>• Rechargeable batteries have not been inserted, or batteries other than rechargeable batteries (alkaline batteries, manganese batteries, etc.) have been inserted.</li> <li>• Rechargeable batteries have been inserted with incorrect polarity.</li> <li>• Rechargeable batteries other than NH-AAA have been inserted.</li> <li>• The rechargeable batteries have deteriorated. Replace the old rechargeable batteries with new ones.</li> <li>• The USB connecting cable is not connected properly.</li> <li>• “USB Charge” is set to “OFF” in the menu. To charge the batteries using your computer, set it to “ON” (page 101).</li> <li>• While playing back files using the built-in speaker, you cannot charge the batteries.</li> </ul>
The IC recorder cannot be turned off.	<ul style="list-style-type: none"> <li>• Slide the POWER/HOLD switch in the direction of “POWER” for more than 2 seconds when the IC recorder is stopped (page 15).</li> </ul>
The IC recorder cannot be turned on.	<ul style="list-style-type: none"> <li>• The power to the IC recorder is off. Slide the POWER/HOLD switch in the direction of “POWER” for more than 1 second (page 15).</li> <li>• The batteries have been inserted with incorrect polarity (page 12).</li> </ul>
The IC recorder is powered off automatically.	<ul style="list-style-type: none"> <li>• When the IC recorder is in the stop mode and you leave the IC recorder without attempting an operation for a certain length of time, the auto power off function will take effect. (The length of time before auto power off is set to “10min” when you purchase the IC recorder.) You can select the length of time before auto power off takes effect in the menu (page 101).</li> </ul>
The IC recorder does not operate correctly.	<ul style="list-style-type: none"> <li>• Take out the batteries and insert them again.</li> </ul>
It takes a long time for the IC recorder to start.	<ul style="list-style-type: none"> <li>• If the IC recorder is required to process a large amount of data, it may take longer for the IC recorder to start. This is not a malfunction of the IC recorder. Wait until the start-up display disappears.</li> </ul>

<b>Symptom</b>	<b>Remedy</b>
The IC recorder does not operate.	<ul style="list-style-type: none"> <li>You may have formatted the memory of the IC recorder using the computer. Use the IC recorder formatting function to format the memory (page 102).</li> </ul>
The IC recorder does not operate, even if you press any button.	<ul style="list-style-type: none"> <li>The batteries are weak (page 14).</li> <li>The power to the IC recorder is off. Slide the POWER/HOLD switch in the direction of “POWER” for more than 1 second (page 15).</li> <li>The HOLD function is activated. Slide the POWER/HOLD switch in the center direction (page 11).</li> </ul>
No sound comes from the speaker.	<ul style="list-style-type: none"> <li>The volume is turned down completely (page 26).</li> <li>Headphones are plugged in (page 58).</li> </ul>
Sound comes from the speaker even when the headphones are plugged in.	<ul style="list-style-type: none"> <li>If you plug in the headphones not securely during playback, the sound may come from the speaker. Unplug the headphones, and then insert them securely.</li> </ul>
The operation indicator does not light.	<ul style="list-style-type: none"> <li>“LED” is set to “OFF.” Display the menu and set “LED” to “ON” (page 98).</li> </ul>
The “Memory Full” animation is displayed and you cannot start recording.	<ul style="list-style-type: none"> <li>The memory is full. Erase some of the files (page 31) or erase all the files after you store them on the other memory media or on your computer.</li> </ul>
The “File Full” animation is displayed and you cannot operate the IC recorder.	<ul style="list-style-type: none"> <li>199 files have been recorded in the selected folder (📁) or 4,074 files (when there are 21 folders) in total have been recorded. Therefore you cannot record another file, or move a file. Erase some of the files (page 31) or erase all the files after you store them on the other memory media or on your computer.</li> </ul>
You cannot record a file.	<ul style="list-style-type: none"> <li>The remaining memory capacity is insufficient.</li> <li>You cannot record a file when you select a folder in the playback-only area (the 🎵 (Music) tab and the 🎧 (Podcast) tab).</li> </ul>

Symptom	Remedy
The playback volume is low.	<ul style="list-style-type: none"> <li>• The volume is turned down completely. Press VOLUME +/- to adjust the volume (page 26).</li> <li>• The recording scene is set to  (Voice Notes). Select a recording scene depending on the current situation (page 34).</li> <li>• “REC Level” is set to “Low ” or “Low(Music) .</li> <li>• Set it to “High .</li> <li>• “Medium .</li> <li>• “High(Music) .</li> <li>• (page 90).</li> <li>• When you set “REC Level” is set to “Manual <b>MAN</b>,” adjust the recording level manually using  or  on the control button (page 39).</li> <li>• If it is difficult to hear small sound of a recorded file, set “V-UP” to “Maximum” or “Medium” (page 61). Playback sound may become more audible.</li> </ul>
The input sound is distorted.	<ul style="list-style-type: none"> <li>• The sound source has parts that are too loud. Set “LIMITER” to “ON” in the menu (page 91).</li> </ul>
You cannot add a recording or an overwrite recording.	<ul style="list-style-type: none"> <li>• “Add/Overwrite” is set to “OFF” in the menu. Set “Add/Overwrite” to “Add” or “Overwrite” (page 91).</li> <li>• The remaining memory capacity is insufficient. The overwritten part will be deleted after the overwriting part finishes recording. Therefore, you can only overwrite within the remaining recording time.</li> <li>• You cannot add or overwrite a recording to a file which was not recorded using the IC recorder.</li> <li>• You cannot add or overwrite a recording to a file in a folder in the playback-only area (the  (Music) tab and the  (Podcast) tab).</li> </ul>
Recording is interrupted.	<ul style="list-style-type: none"> <li>• The VOR function is activated. Set “VOR” to “OFF” in the menu (page 45).</li> </ul>
The VOR function does not work.	<ul style="list-style-type: none"> <li>• During manual recording and synchronized recording, the VOR function does not work.</li> </ul>

Symptom	Remedy
When recording from other equipment, the input level is too strong or not strong enough.	<ul style="list-style-type: none"> <li>• Connect the headphone jack of other equipment to the  (microphone) jack of the IC recorder and adjust the volume level on the piece of equipment connected to the IC recorder.</li> </ul>
Playback sound becomes loud unexpectedly.	<ul style="list-style-type: none"> <li>• “V-UP” is set to “Maximum” or “Medium.” Set it to “OFF” (page 61).</li> </ul>
Playback speed is too fast or too slow.	<ul style="list-style-type: none"> <li>• The playback speed is adjusted in DPC. Slide the DPC(SPEED)/KEY CTRL switch to “OFF” or press  or  on the control button to adjust the speed in DPC again (page 63).</li> </ul>
You cannot divide a file.	<ul style="list-style-type: none"> <li>• You need a certain amount of free space in the memory to divide a file.</li> <li>• 199 files have been recorded in the selected folder (). Erase some of the files (page 31) or erase all the files after you store them on the other memory media or on your computer.</li> <li>• Because of the system limitations, you may not be able to divide a file at the very beginning or at the very end of the file.</li> <li>• You cannot divide files other than those recorded using the IC recorder (e.g., a file transferred from a computer).</li> </ul>
The memory card is not recognized.	<ul style="list-style-type: none"> <li>• Since the memory card may contain image data or other files, the memory required for creating initial folders is insufficient. Use Windows Explorer, Macintosh desktop, or other tools to erase unwanted files or initialize the memory card on the IC recorder.</li> <li>• Switch the memory media of the IC recorder to “Memory Card” (page 49).</li> <li>• Remove a memory card and check the side of the memory card. Then insert it with correct side and direction.</li> </ul>
“--:--” is displayed.	<ul style="list-style-type: none"> <li>• You have not set the clock (page 16).</li> </ul>
“--y--m--d” or “--:--” is displayed on the REC Date display.	<ul style="list-style-type: none"> <li>• The date of recording will not be displayed if you recorded the file when the clock was not set.</li> </ul>

Symptom	Remedy
There are fewer menu items displayed in the menu mode.	<ul style="list-style-type: none"> <li>The menu items displayed are different depending on the operation modes (stop mode, playback mode, and recording mode) (page 86).</li> </ul>
The remaining time displayed in the display window is shorter than that displayed in the supplied Sound Organizer software.	<ul style="list-style-type: none"> <li>The IC recorder requires a certain amount of memory for system operation. That amount is subtracted from the remaining time, which is the reason for the difference.</li> </ul>
The battery life is short.	<ul style="list-style-type: none"> <li>The battery life on page 128 is based on playback with the volume level set to 20. The battery life may shorten depending on the operation of the IC recorder.</li> </ul>
There is no battery power remaining after you have left the batteries inserted for long time without using the IC recorder.	<ul style="list-style-type: none"> <li>Even if you do not use the IC recorder, the batteries are consumed slightly. If you do not intend to use the IC recorder for an extended period of time, it is recommended that you turn the power off (page 15) or remove the batteries. Moreover, if you set "Auto Power Off" to a short span in the menu (page 101), you can prevent the batteries from being consumed due to forgetting to turn the IC recorder off.</li> </ul>
There is no battery power remaining when you disconnect the IC recorder from the USB AC adaptor after you have left the IC recorder connected for long time, fully charged.	<ul style="list-style-type: none"> <li>Once the batteries are fully charged, they are not recharged automatically, even if you leave the IC recorder connected to the USB AC adaptor. You can use the IC recorder while it is connected to the USB AC adaptor, but charge it again after disconnecting it.</li> </ul>
"COLD" or "HOT" is flashing instead of the battery indicator.	<ul style="list-style-type: none"> <li>The environmental temperature is out of the range for charging. Charge the batteries in an environment with a temperature of 5 °C - 35 °C (41 °F - 95 °F).</li> </ul>

Symptom	Remedy
The battery life of the rechargeable batteries is short.	<ul style="list-style-type: none"> <li>• You are using the rechargeable batteries in an environment with a temperature of under 5 °C (41 °F). Charge the batteries in an environment with a temperature of 5 °C - 35 °C (41 °F - 95 °F).</li> <li>• The IC recorder has not been used for a certain time. Charge and discharge the rechargeable batteries using the IC recorder several times.</li> <li>• Replace the old rechargeable batteries with new ones.</li> <li>• The battery indicator is displayed only for a short time, however, the rechargeable batteries are not charged completely. It takes about 4 hours to fully charge exhausted batteries.</li> </ul>
Menu does not reflect the change in settings.	<ul style="list-style-type: none"> <li>• If the batteries are removed just after the menu setting is changed, or the menu setting is changed using “IC recorder settings” of the Sound Organizer software with the exhausted batteries inserted, the menu setting may not function.</li> </ul>
A character in a folder or file name is displayed in unreadable characters.	<ul style="list-style-type: none"> <li>• The IC recorder cannot support or display some special characters and symbols that are entered on a computer using Windows Explorer or the Macintosh desktop.</li> </ul>
The “Accessing...” animation display does not disappear.	<ul style="list-style-type: none"> <li>• If the IC recorder is required to process excessive amount of data, the animation may be displayed for an extended period of time. This is not a malfunction of the IC recorder. Wait until the message disappears.</li> </ul>
It takes a long time to copy a file.	<ul style="list-style-type: none"> <li>• If the file size of a file is large, it takes a considerable time to finish copying. Wait until the copying is finished.</li> </ul>
The transferred files are not displayed.	<ul style="list-style-type: none"> <li>• The IC recorder can recognize up to 8 levels of folders transferred to the IC recorder.</li> <li>• If files are incompatible, other than an LPCM(.wav)/MP3(.mp3)/LPEC(.msv)/WMA(.wma)/AAC-LC(.m4a) file that the IC recorder supports, they may not be displayed. See page 125.</li> </ul>

<b>Symptom</b>	<b>Remedy</b>
The IC recorder is not recognized by your computer. A folder/file cannot be transferred from your computer.	<ul style="list-style-type: none"><li>• Disconnect the IC recorder from your computer and reconnect it.</li><li>• Do not use a USB hub or USB extension cable other than the supplied USB connecting cable. Connect the IC recorder to your computer using the supplied USB connecting cable.</li><li>• Operation is not guaranteed if you use any system requirements other than those described on page 124.</li><li>• Depending on the USB port position, the IC recorder may not be recognized. If this happens, try another port.</li></ul>
The file transferred from your computer cannot be played back.	<ul style="list-style-type: none"><li>• The file format may differ from those that can be played back using the IC recorder (LPCM(.wav)/MP3(.mp3)/LPEC(.msv)/WMA(.wma)/AAC-LC(.m4a)). Check the file name (page 125).</li></ul>
The computer cannot start.	<ul style="list-style-type: none"><li>• If you reboot the computer with the IC recorder connected to the computer, the computer may freeze or may not start properly. Disconnect the IC recorder from the computer and reboot the computer again.</li></ul>

## Sound Organizer

Refer to the help files of the Sound Organizer software, too.

---

Symptom	Cause/Remedy
The Sound Organizer software cannot be installed.	<ul style="list-style-type: none"><li>• The free disk or memory space on the computer is too small. Check the hard disk and memory space.</li><li>• You are trying to install the software into the operating system that the Sound Organizer software does not support. Install the software into the supported operating system (page 114).</li><li>• In Windows XP, you have logged on using a user name belonging to a user account with limitations. Or in Windows Vista or Windows 7, you have logged on using a guest account. Make sure to log on using a user name with computer administrator privileges.</li></ul>
The IC recorder cannot be properly connected.	<ul style="list-style-type: none"><li>• Check that the installation of the software has been successful. Also check the connection as follows:<ul style="list-style-type: none"><li>– When using an external USB hub, connect the IC recorder directly to the computer.</li><li>– Disconnect and then connect the cable with the IC recorder.</li><li>– Connect the IC recorder to another USB port.</li></ul></li><li>• Your computer may be in the system standby/hibernate mode. Do not let your computer enter into the system standby/hibernate mode while being connected to the IC recorder.</li><li>• Save a backup copy of all of the data stored on the built-in memory or the memory card, and then format the built-in memory or the memory card using the formatting function in the menu (page 102).</li></ul>

---





<b>Symptom</b>	<b>Cause/Remedy</b>
Playback sound from the computer is low./No sound is emitted from the computer.	<ul style="list-style-type: none"><li>• No sound board is installed.</li><li>• No speaker is built-in or connected to the computer.</li><li>• The volume of the sound is turned down.</li><li>• Turn up the volume on the computer. (Refer to the instruction manual of the computer.)</li><li>• The volume of WAV files can be changed and saved using the “Increase Volume” feature of the Microsoft Sound Recorder.</li></ul>
Stored files cannot be played back or edited.	<ul style="list-style-type: none"><li>• You cannot play back files whose file format the Sound Organizer software does not support. Depending on the file format, you cannot use part of editorial features of the software. Refer to the help files of the Sound Organizer software.</li></ul>
The counter or slider moves incorrectly, or noise is heard.	<ul style="list-style-type: none"><li>• This happens when you play back files that you divided, combined, overwrote, or added a recording. Store a file on your computer first*, and then add it to the IC recorder. (*Select the saving file format that suits the IC recorder you use.)</li></ul>
Operation is slow when there are many files.	<ul style="list-style-type: none"><li>• When the total number of files increases, the operation becomes slower, regardless of the length of the recording time.</li></ul>
Display does not work during saving, adding, or deleting of files.	<ul style="list-style-type: none"><li>• It takes a longer time to copy or delete long files. Wait until the copying is finished. After completing operations, the display works normally.</li></ul>
The software ‘hangs’ when the Sound Organizer software starts up.	<ul style="list-style-type: none"><li>• Do not disconnect the connector of the IC recorder while the computer is communicating with the IC recorder. Otherwise the computer operations become unstable or the data inside the IC recorder may be damaged.</li><li>• There may be conflict between the software and other driver or application.</li></ul>

# Message List

Message	Cause/Remedy
HOLD	<ul style="list-style-type: none"><li>• All the button operations are disabled because the IC recorder is in the HOLD status to prevent unintentional operations. Slide the POWER/HOLD switch towards the center to release the IC recorder from the HOLD status (page 11).</li></ul>
Low Battery	<ul style="list-style-type: none"><li>• Batteries are exhausted. Replace the old LR03 (size AAA) alkaline batteries with new ones. Or charge the rechargeable batteries (page 12) or replace the old rechargeable batteries with new ones.</li></ul>
Memory Card Error	<ul style="list-style-type: none"><li>• An error occurred while a memory card was being inserted into the memory card slot. Remove and try inserting it again. If this message persists, use a new memory card.</li></ul>
Memory Card Not Supported	<ul style="list-style-type: none"><li>• A memory card that the IC recorder does not support is inserted. See “About compatible memory cards” on page 47.</li></ul>
Unknown Memory Card	<ul style="list-style-type: none"><li>• An M2™ that the IC recorder does not authorize is inserted. See “About compatible memory cards” on page 47.</li></ul>
Memory Card Locked	<ul style="list-style-type: none"><li>• The memory card is write-protected. A write-protected memory card cannot be used with the IC recorder.</li></ul>
Read Only Memory Card	<ul style="list-style-type: none"><li>• A read-only memory card is inserted. A read-only memory card cannot be used with the IC recorder.</li></ul>
Memory Card Access Denied	<ul style="list-style-type: none"><li>• Since a memory card containing an access control function is inserted, you cannot use it.</li></ul>
Memory Full	<ul style="list-style-type: none"><li>• The remaining memory capacity of the IC recorder is insufficient. Erase some files before recording.</li></ul>

Message	Cause/Remedy
File Full	<ul style="list-style-type: none"><li>When there are already the maximum number of files in the selected folder or the total number of files stored on the IC recorder has exceeded the maximum, you cannot record a new file. Erase some files before recording.</li></ul>
File Damaged	<ul style="list-style-type: none"><li>You cannot play back or edit files, because the data of the selected file is damaged.</li></ul>
Format Error	<ul style="list-style-type: none"><li>The IC recorder cannot be turned on using the computer because there is no copy of the control file required for operation. Format the IC recorder using the formatting function in the menu (page 102).</li></ul>
Process Error	<ul style="list-style-type: none"><li>The IC recorder failed in memory access. Remove and then re-insert the batteries.</li><li>Save a backup copy of your data and format the IC recorder using the menu (page 102).</li></ul>
Stop and Reinsert Memory Card	<ul style="list-style-type: none"><li>A memory card was inserted during recording or playback. Remove the memory card and insert it while the IC recorder is in the stop mode.</li></ul>
Set Date&Time	<ul style="list-style-type: none"><li>Set the clock; otherwise, you cannot set the alarm.</li></ul>
Set Add/Overwrite	<ul style="list-style-type: none"><li>“Add/Overwrite” in the menu is set to “OFF.” You cannot add a recording or an overwrite recording (page 91).</li></ul>
Track Marks are Full	<ul style="list-style-type: none"><li>You can set up to 98 track marks for a file. Cancel unwanted track marks (page 77).</li></ul>
No File	<ul style="list-style-type: none"><li>The selected folder does not have any files. You cannot move a file or set the alarm, etc., because of this.</li></ul>
No Track Marks	<ul style="list-style-type: none"><li>There are no track marks when you attempt to erase or locate a track mark.</li></ul>
No Setting	<ul style="list-style-type: none"><li>If you have not set the alarm, the alarm list will not be displayed. Make the alarm setting for “New” (page 68).</li></ul>

Message	Cause/Remedy
Low Battery Level	<ul style="list-style-type: none"> <li>You cannot format the memory or erase all the files in a folder because of insufficient battery power. Replace the old LR03 (size AAA) alkaline batteries with new ones. Or charge the rechargeable batteries (page 12) or replace the old rechargeable batteries with new ones.</li> </ul>
File Protected	<ul style="list-style-type: none"> <li>The selected file is protected or is a “Read only” file. You cannot erase it. Cancel the protection on the IC recorder or cancel “Read only” on your computer to edit the file using the IC recorder (page 84).</li> </ul>
Already Set	<ul style="list-style-type: none"> <li>The selected file has already been set for alarm playback. Select the other file.</li> <li>You set the alarm to play back a file at a date and time previously set on another file. Change the alarm setting.</li> </ul>
Past Date/Time	<ul style="list-style-type: none"> <li>You set the alarm when the time has already passed. Check it and set the appropriate date and time (page 68).</li> </ul>
Settings are Full	<ul style="list-style-type: none"> <li>You can set up to 30 alarms. Cancel unwanted alarms.</li> <li>When you operate “Change Folder Name” function in the menu, there are 10 folders with the same folder name as the folder you selected. Please choose a different folder name from the templates (page 82).</li> </ul>
Unknown Data	<ul style="list-style-type: none"> <li>This data is not in a file format that is supported by the IC recorder. The IC recorder supports LPCM(.wav)/MP3(.mp3)/LPEC(.msv)/WMA(.wma)/AAC-LC(.m4a) files. For details, see “Design and specifications” on page 125.</li> <li>You cannot play back copyright protected files.</li> </ul>

Message	Cause/Remedy
Invalid Operation	<ul style="list-style-type: none"><li>• You cannot divide or set a track mark in files in the folder in the playback-only area (the  (Music) tab and the  (Podcast) tab).</li><li>• When a memory card has a bad block on it, the card cannot be written to. Prepare a new memory card to replace the current one.</li><li>• The file name has reached the maximum number of characters; you cannot divide the file. Shorten the file name.</li><li>• The “Divide All Track Marks” function cannot be used because there is a track mark within 0.5 seconds from the dividing position.</li><li>• The “Divide All Track Marks” function cannot be used because there is a track mark within 0.5 seconds from the beginning of a file or the end of a file.</li><li>• The file length is less than 1 second; you cannot divide such a short file.</li><li>• The “Divide Current Position” function cannot be used at a position within 0.5 seconds from the beginning of a file or the end of a file.</li><li>• You cannot use the editorial functions in the menu for LPEC(.msv) files.</li></ul>
New File	<ul style="list-style-type: none"><li>• The file being recorded has reached the maximum size limit (2 GB for an LPCM file, and 1 GB for an MP3 file). The file will be divided automatically and recording will continue as a new file.</li></ul>
Invalid when Noise Cut is ON	<ul style="list-style-type: none"><li>• When the NOISE CUT switch is set to “ON,” the effect function does not work. Cancel the noise cut setting (page 60).</li></ul>
Change Folder	<ul style="list-style-type: none"><li>• If there are no files in the  or  folder, no folders are displayed in the display window. Only a folder with a file will be displayed.</li></ul>
Cannot Divide - Exceeds Max 199 Files in Folder	<ul style="list-style-type: none"><li>• When there are already 199 files in the selected folder or the total number of files stored on the IC recorder exceeds the maximum, you cannot divide a file. Erase some files before dividing a file.</li></ul>

Message	Cause/Remedy
Same File Name Exists	<ul style="list-style-type: none"> <li>• A file of the same file name already exists in the destination folder when a file is copied to the other memory media.</li> </ul>
No Memory Card	<ul style="list-style-type: none"> <li>• There is no memory card inserted into the memory card slot when you attempt to set the “Select Memory,” “File Copy,” or “Cross-Memory REC” menus.</li> </ul>
Continue REC in Other Memory	<ul style="list-style-type: none"> <li>• When “Cross-Memory REC” in the menu is enabled and the memory media currently being used becomes full during recording, the IC recorder switches to the other memory media and continues recording.</li> </ul>
Invalid in Manual Setting	<ul style="list-style-type: none"> <li>• “REC Level” in the menu is set to “Manual <b>MAN</b>.” The VOR function does not work (page 90).</li> </ul>
Manual Setting Only	<ul style="list-style-type: none"> <li>• “REC Level” in the menu is not set to “Manual <b>MAN</b>.” The LIMITER function does not work (page 90).</li> </ul>
Erased Track Marks too near Divide Point	<ul style="list-style-type: none"> <li>• When there is a track mark set within 0.5 seconds from the dividing position, the track mark is automatically erased.</li> </ul>
No operation with Memory Card	<ul style="list-style-type: none"> <li>• You cannot set an alarm in a file stored on a memory card. Switch the memory media of the IC recorder to “Built-In Memory” (page 49, 50).</li> </ul>
System Error	<ul style="list-style-type: none"> <li>• A system error other than the above has occurred. Remove the batteries and re-insert them.</li> </ul>

# System Limitations

There are some system limitations of the IC recorder. Troubles as mentioned below are not malfunctions of the IC recorder.

Symptom	Cause/Remedy
You cannot record files up to the maximum recording time.	<ul style="list-style-type: none"><li>• If you record files in a mixture of the recording modes, the recordable time varies from the maximum recording time of the highest recording mode to those of the lowest recording mode.</li><li>• The sum of the number on the counter (elapsed recording time) and the remaining recording time may be less than the IC recorder's maximum recording time.</li></ul>
You cannot display or play back music files in order.	<ul style="list-style-type: none"><li>• If you have transferred music files using your computer, those files may not be transferred in order of transfer because of system limitations. If you transfer music files from your computer to the IC recorder one by one, you can display and play back the music files in transferred order.</li></ul>
A file is divided automatically.	<ul style="list-style-type: none"><li>• The file being recorded has reached the maximum size limit (2 GB for an LPCM file, and 1 GB for an MP3 file). Therefore it is automatically divided.</li></ul>
You cannot enter lower-case characters.	<ul style="list-style-type: none"><li>• Depending on the combination of the characters used for the folder name that was made on your computer, those characters may change to all capitals.</li></ul>
“□” is displayed in place of a folder name, title, artist name, or file name.	<ul style="list-style-type: none"><li>• A character which cannot be displayed on the IC recorder has been used. Using your computer, replace it with one which can be displayed on the IC recorder.</li></ul>
When you set A-B repeat playback, the set positions move a little.	<ul style="list-style-type: none"><li>• Depending on the files, the set positions may move.</li></ul>

---

**Symptom****Cause/Remedy**

---

The remaining recording time becomes shorter when you divide a file.

- You need a certain amount of free space for a file management area to divide a file, therefore the remaining recording time will be shortened.
-

# Display Window Guide

## Display when stopped

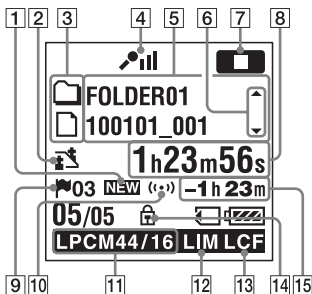

- 1 Newly arriving podcast indication
- 2 Scene select indication  
Displays the currently selected scene used for recording. Appears when a scene is set.
  - Meeting
  - Voice Notes
  - Interview
  - Music
  - My Scene

- 3 File information type indicator
  - Folder where you can record a file
  - Folder for playback only
  - Folder for podcast files
  - Title name
  - Artist name
  - File name
- 4 Microphone sensitivity indicator
  - High
  - Medium
  - Low
  - High(Music)
  - Low(Music)
  - MAN : Manual  
Displays the recording level when “Manual **MAN**” is set.
- 5 File information  
Displays the information for each file according to the file information type (folder name, title name, artist name, file name).
- 6 File information switch operation guide  
You can switch the file information display in order by pushing ▲ or ▼ on

the control button. You can also display the recording level meter.

**7** Operation mode indicator

Displays the following, depending on the current operation of the IC recorder.

 : stop



 : playback

**REC** : recording

 : recording standby/recording pause (flashing)



**VORREC** : recording with the VOR function



**VOR** : recording pause with the VOR function (flashing)

If you press  REC/PAUSE to pause recording when “VOR” is set to “ON” in the menu, only “” flashes.

**SYNCREC** : synchronized recording

**SYNC** : synchronized recording pause (flashing)

  : review/fast backward, cue/ fast forward

  : going backward/forward continuously

**8** Elapsed time/Remaining time/

Recording date and time indication

**9** Track mark indicator

Displays the track mark number just before the current position. Appears when a track mark is set for a file.

**10** Alarm indicator

Appears when the alarm is set in a file.

**11** Recording mode indicator

Displays the recording mode set using the menu when the IC recorder is in the stop mode, and displays the current recording mode when the IC recorder is in the playback or recording mode.

**LPCM 44/16** : LPCM file recorded or transferred with the IC recorder

**MP3 8k** , **MP3 48k** , **MP3 128k** ,

**MP3 192k** , **MP3 320k** : MP3 file recorded or transferred with the IC recorder

When the files are transferred from your computer, file formats only (**LPCM** / **MP3**) are displayed.

**WMA** : WMA files transferred

**AAC** : AAC-LC files transferred

**LPEC** : LPEC files transferred

Displays as follows when the IC recorder cannot get the recording mode.

**---** : Unknown

- 12** Limiter indicator (only displayed during manual recording)  
 Appears when “LIMITER” is set to “ON” in the menu.
- 13** LCF (Low Cut Filter) indicator  
 Appears when “LCF(Low Cut)” is set to “ON” in the menu.
- 14** Protect indicator  
 Appears when the protection is set for a file.
- 15** Remaining recording time  
 Displays the remaining recording time in hours, minutes, and seconds.  
 If there is more than 10 hours time remaining, the time is displayed in hours.  
 If there is more than 10 minutes and less than 10 hours time remaining, the time is displayed in hours and minutes.  
 If there is less than 10 minutes time remaining, the time is displayed in minutes and seconds.

### Display when recording (auto (AGC) recording)

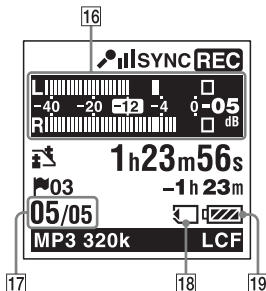

### Display when recording (manual recording)

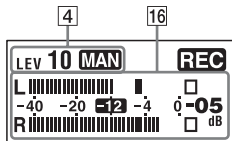

### Display when recording (pre-recording)

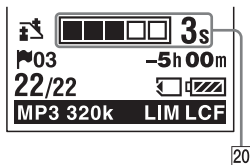

## 16 Level meter display

Level meter display in auto (AGC) recording mode. In manual recording, the level meter whose colors are reverse is displayed.

## 17 File number

The selected file number is displayed in the numerator and the total number of files in the folder is displayed in the denominator.

## 18 Memory card indication

When “Memory Card” is selected as “Select Memory,” the indication is displayed. When “Built-In Memory” is selected, no indication is displayed.

## 19 Battery indicator

## 20 Pre-recording buffering time display

Appears when the IC recorder is in the recording standby mode.

## Display during playback

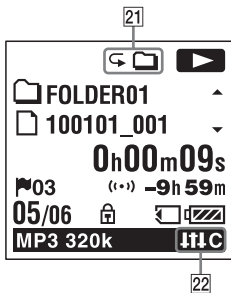

## 21 Playback mode indicator

1: Appears when a file is played back.

: Appears when files in one folder are played back continuously.

ALL: Appears when all the files are played back continuously.

1: Appears when one file is played back repeatedly.

: Appears when files in one folder are played back repeatedly.

: Appears when all the files are played back repeatedly.

**22** Noise cut/Effect indicator

Appears when the NOISE CUT switch is set to “ON,” or “Effect” is set in the menu.

**N-CUT** : Noise cut

**POP** : Pop

**ROCK** : Rock

**JAZZ** : Jazz

**BA1** : Bass1

**BA2** : Bass2

**HC** : Custom

**23** HOLD indicator

Appears when the IC recorder is in the HOLD status to prevent unintentional operations.

To release the HOLD status, slide the POWER/HOLD switch towards the center (page 11).

### Display in the HOLD status

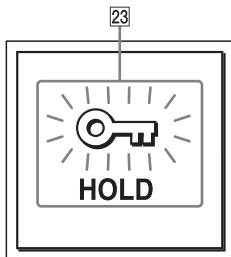

# Index

## A

- AAC-LC files ..... 125
- A-B repeat ..... 67
- Adding a recording ..... 40, 86, 91
- Adjusting the volume ..... 26, 57
- Alarm ..... 68, 86, 95
- Alkaline battery ..... 129
- Auto (AGC) recording ..... 22

## B

- Battery indicator ..... 14
- Battery life ..... 128

## C

- Calendar ..... 59, 87, 97
- Changing a folder name ..... 82, 87, 96
- Changing the Scene Select settings ..... 36, 86, 88
- Copying a file to the other memory media ..... 73, 87, 96
- Copying files to your computer ..... 109
- Copying music files to the IC recorder ..... 110
- Cross-memory recording ..... 50, 86, 92
- Cue ..... 58

## D

- Digital voice up ..... 61, 86, 93
- Displaying the current date and time ..... 18
- Dividing a file at all the track mark positions ..... 80, 87, 97
- Dividing a file at the current position ..... 79, 87, 96
- DPC (Digital Pitch Control) ..... 63

## E

- Easy search ..... 58, 86, 94
- Editing files ..... 72
- Effect ..... 64, 86, 94
- Erasing ..... 31
- Erasing a track mark ..... 77, 87, 96
- Erasing all files in a folder ..... 74, 87, 97
- Erasing all the track marks ..... 77, 87, 97
- External microphone ..... 52

## F

- Folder ..... 20, 25, 72, 104

## H

- HOLD ..... 11

<b>I</b>	
Index to parts and controls	
Display window .....	147
Front .....	9
Rear .....	9
Input selection .....	52, 86, 93
<b>K</b>	
Key control .....	63
<b>M</b>	
Maintenance .....	122
Manual recording .....	39
Memory card .....	47, 122
Memory Stick Micro™ (M2™) .....	47, 106
Menu	
Add/Overwrite .....	86, 91
Alarm .....	86, 95
Auto Power Off .....	87, 101
Backlight .....	87, 99
Beep .....	87, 100
Calendar .....	87, 97
Change Folder Name .....	87, 96
Cross-Memory REC .....	86, 92
Date&Time .....	87, 100
Display .....	87, 98
Divide All Track Marks .....	87, 97
Divide Current Position .....	87, 96
Easy Search .....	86, 94
Effect .....	86, 94
Erase All .....	87, 97
Erase All Track Marks .....	87, 97
Erase Track Mark .....	87, 96
File Copy .....	87, 96
Format .....	87, 102
Language .....	87, 100
LCF(Low Cut) .....	86, 90
LED .....	87, 98
LIMITER .....	86, 91
Making settings for the menu .....	85
Menu settings .....	86
Move File .....	87, 96
Noise Cut Level .....	86, 93
Play Mode .....	86, 95
PRE REC .....	86, 91
Protect .....	87, 96
REC Level .....	86, 90
REC Mode .....	86, 89
Scene Edit .....	86, 88
Select Input .....	86, 93
Select Memory .....	87, 99
SYNC REC .....	86, 92
Time Display .....	87, 100

USB Charge .....	87, 101
VOR .....	86, 92
V-UP .....	86, 93
Message list .....	140
Microphone directionality .....	20, 33
microSD card .....	47, 106
Monitoring the recording .....	57
Moving a file .....	72, 87, 96
MP3 files .....	125

## **N**

Noise .....	121
Noise cut .....	60
Noise cut level .....	61, 86, 93

## **O**

Overwrite recording .....	42, 86, 91
---------------------------	------------

## **P**

Pause recording .....	24
Playback .....	25, 58
Playback modes .....	66, 86, 95
Podcast .....	113
POWER/HOLD switch .....	11, 15
Precautions .....	121
Pre-recording .....	43, 86, 91
Protecting a file .....	84, 87, 96

## **R**

Rechargeable battery .....	12, 119, 128
Recharging the batteries .....	12
Recording .....	20, 33
Recording from a telephone .....	53
Recording from other equipment .....	53
Recording level .....	39
Recording time .....	127
Recording with other equipment .....	71
Review .....	24, 58

## **S**

Scene selection .....	34
Setting the clock .....	16, 87, 100
Setting the language .....	19, 87, 100
Sound Organizer .....	113
Specifications .....	124
Switching the memory .....	49, 87, 99
Synchronized recording .....	54, 86, 92
System limitations .....	145
System requirements .....	114, 124

## **T**

Tab view .....	28
Track mark .....	76
Troubleshooting .....	130

## **U**

USB AC adaptor .....	119
USB memory .....	112
Using the IC recorder with your computer .....	103

## **V**

VOR (Voice Operated Recording) .....	45, 86, 92
---	------------

## **W**

WMA files .....	125
-----------------	-----