

Premium Powered 8" Subwoofer Setup Guide



Audioengine, Ltd.
support@audioengineusa.com
www.audioengineusa.com



© 2008 Audioengine Corp. All Rights Reserved.

Copyright Notice

Audioengine and Audioengine Sub 8 are trademarks of Audioengine Ltd.



Contents

Safety Information	Page 1
Basic Information	Page 2
Introduction	
Unpacking	
Box Contents	
Cleaning	
Placement	Page 3
Features	Page 4
Controls	Pages 4-7
Connections	Pages 8-10
Setup Diagrams	
Final Adjustments	Page 11
Troubleshooting	Pages 12-14
Warranty Information	Page 8
Specifications	Page 15
Materials and Construction	
Company Information	Page 16
Support	

Basic Safety Instructions

- Read these instructions for all components before using this product.
- Keep these instructions for future reference.
- Heed all warnings on the product and in the owner's guide.
- Follow all instructions.
- Do not use this apparatus near water or moisture. Do not use this product near a bathtub, washbowl, kitchen sink, laundry tub, in a wet basement, near a swimming pool, or anywhere else that water or moisture are present.
- Clean only with a dry cloth and as directed by the manufacturer. Unplug this product from the wall outlet before cleaning.
- Do not block any ventilation openings. Install in accordance with the manufacturer's instructions. To ensure reliable operation of the product and to protect it from overheating, put the product in a position and location that will not interfere with its proper ventilation. For example, do not place the product on a bed, sofa, or similar surface that may block the ventilation openings. Do not put it in a built-in system, such as a bookcase or a cabinet that may keep air from flowing through its ventilation openings.
- Do not install near any heat sources, such as radiators, heat registers, stoves or other apparatus that produce heat.
- Do not defeat the safety purpose of the polarized or grounding-type plug. A polarized plug has two blades with one wider than the other. A grounding-type plug has two blades and a third grounding prong. The wider blade or third prong are provided for your safety. If the provided plug does not fit in your outlet, consult an electrician for replacement of the obsolete outlet.
- Protect the power cord from being walked on or pinched, particularly at plugs, convenience receptacles, and the point where they exit from the apparatus.
- Only use attachments or accessories specified by the manufacturer.
- Use only with the cart, stand, tripod, bracket or table specified by the manufacturer or sold with the apparatus. When a cart is used, use caution when moving the cart/apparatus combination to avoid injury from tip-over.
- Unplug this apparatus during lightning storms or when unused for long periods of time to prevent damage to this product.
- Refer all servicing to qualified service personnel.
- Servicing is required when the apparatus has been damaged in any way such as power supply cord or plug is damaged, liquid has been spilled or objects have fallen into the apparatus, the apparatus has been exposed to rain or moisture, does not operate normally, or has been dropped. Do not attempt to service this product yourself. Opening or removing covers may expose you to dangerous voltages or other hazards. Please contact the manufacturer to be referred to an authorized service center near you.
- To prevent risk of fire or electric shock, avoid over loading wall outlets, extension cords, or integral convenience receptacles .
- Do not let objects or liquids enter the product as they may touch dangerous voltage points or short out parts that could result in a fire or electric shock.
- See product enclosure bottom for safety related markings.
- Use Proper Power Sources. Plug the product into a proper power source, as described in the operating instructions or as marked on the product.
- Avoid power lines— Use extreme care when installing an outside antenna system to keep from touching power lines or circuits, as contact with them may be fatal. Do not install external antennas near overhead power lines or other electric light or power circuits, nor where an antenna can fall into such circuits or power lines.

This device complies with part 15 of the FCC Rules.

Operation is subject to the following two conditions: This device may not cause harmful interference and this device must accept any interference received, including interference that may cause undesired operation.

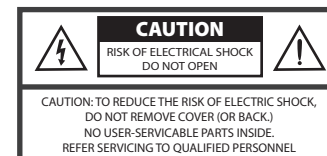



Introduction

Welcome to the Audioengine family and congratulations on your purchase of the Audioengine S8 Premium Powered 8" Subwoofer. The Audioengine team is dedicated to bringing you the highest quality listening experience possible and the Audioengine S8 (AS8) is designed with the same attention to detail and operational simplicity as other Audioengine products. Our goal is to get you to your music as simply as possible without all the "gadget tinkering" that other products generally require. As with our other past efforts, we thank all our customers and resellers for helping us create another great Audioengine product!

Unpacking

Your Audioengine speakers were carefully tested and inspected before packaging and shipping. After unpacking please check for any damage. It is rare that a unit is damaged during shipping, but if this does happen contact the shipping company immediately. We recommend that you keep the original carton and packing material for any possible future shipping.

Box Contents

- AS8 Powered Subwoofer
- AC power cable
- 1/8" mini-jack audio cable, 2 meters (~6.5 feet)
- RCA audio cable, 2 meters (~6.5 feet)
- Drawstring cable bag
- Drawstring subwoofer bag
- Setup guide

Cleaning

Your AS8 subwoofer is designed for years of use with no maintenance as long as you avoid exposure of the AS8 to moisture or high temperatures. The hand-finished MDF wood cabinets are very durable and are easily cleaned by wiping down with a soft, dry cloth. We do not recommend using cleaners or solvents.

Placement

We think you'll find your AS8 to be forgiving with regards to room placement and control settings, so if you're not an audio expert don't be intimidated by setting up your subwoofer. The most important thing to remember is there really is no right or wrong room placement for your AS8, but hopefully the simple tips that follow will be useful.

As subwoofers produce audio in a frequency range below 100Hz, it's difficult to hear where these low sounds are coming from, which is why subwoofer placement is not critical. Room size and construction along with furniture and floor coverings do make a difference, however, so try different locations while listening to some of your favorite music to get an idea of how placement affects the sound.

Here are 3 room locations to try out:

- 1 In a corner– which will usually increase subwoofer loudness. Typically the front right and left corners sound the most natural, though rear corner placement is also an option.
- 2 Along a wall– which tends to give moderate bass performance with increased audio quality over corner placement.
- 3 Alongside one of the front speakers– which may blend better with the overall system, but can also sacrifice some subwoofer loudness.

Note: We recommend at least 3 inches of clearance around cabinet with good air circulation. Never cover the subwoofer or place it where the built-in amplifier could be covered.



Audioengine S8 Features

- Super-compact size
- 8" custom downfiring woofer
- Wireless-ready!
- Solid hand-finished, front-ported cabinet
- Auto sleep power saving mode
- Dual line-level inputs (RCA and mini-jack)
- All cables included
- Excellent performance for music, movies, and videogames
- A perfect bass extension for Audioengine powered speakers!

Wireless Ready!

If you decide to place your AS8 away from your powered speakers or receiver, check out the Audioengine W1 wireless adapters (shameless product plug) or Apple's Airport Express for high-quality wireless options. The AS8 has a built-in AC outlet on the rear panel that's perfect for powering these wireless products.

Controls

Your AS8 Powered Subwoofer offers simple yet versatile setting options. After you've become familiar with what these settings do, don't hesitate to experiment with them to find the sound that works best with your system. When you set up your subwoofer for the first time, you will probably make adjustments a few times before you hear what you like. Start with the volume at 50% and keep in mind that as with subwoofer room placement, there are really no right or wrong settings.

Following is an overview of the subwoofer controls and connections:

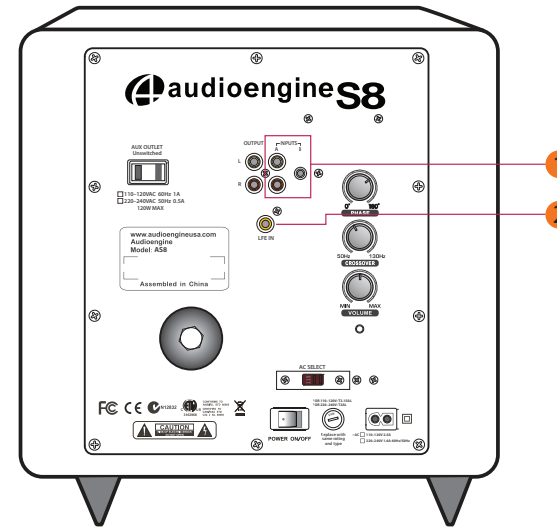

1 Inputs

The RCA and 3.5mm mini-jack inputs are line-level audio inputs used for connecting the output of your audio source (receiver, TV, iPod, computer, etc.) into your AS8 subwoofer. Both inputs are active so no switching is required if you wish to use inputs from 2 different audio sources plugged in at the same time.

Note: If your receiver has a single (mono) subwoofer output, connect an RCA-cable from this output to the RIGHT RCA input on the AS8 rear panel.

2 LFE In

If your preamplifier or receiver has an LFE ("Low Frequency Effects") input or single SUB output connect it to this "LFE In" input connector on the subwoofer.

Note: Most receivers have a subwoofer preamp mono or stereo output, so LFE will most-likely remain unconnected.



3 Output

The Output connectors provide a full-range line-level output to speakers or another subwoofer. This Output is used whenever a signal is connected to one of the 2 subwoofer inputs.

Note: The volume level of this Output connection is controlled by the audio input source, not the volume control on the subwoofer.

4 Phase

The Phase control is used to blend the sound of the subwoofer with the other speakers in your system. Phase is the degree to which the subwoofer speaker and other speakers are moving in and out at the same time. Once you have chosen a location for your subwoofer, try turning the Phase control in small amounts while you listen for the most bass from your favorite listening position. Sometimes no difference will be heard, which is OK. There is no correct Phase setting and it is not uncommon for the subwoofer to sound similar at every setting, depending on your room and location of the subwoofer. If you don't hear a difference go ahead and set the Phase knob at the 0 position.

5 Crossover

The Crossover control is used to set the subwoofer high frequency cutoff point, which is the point at which the subwoofer transitions to your other speakers. For example, if the Crossover control is set to the 50Hz mark then the sub will play all frequencies up to 50Hz. All frequencies from 50Hz and higher will then be played by the other speakers. Fine-tune the Crossover setting by ear for the smoothest blend with your main speakers. The best setting of the Crossover control will depend on speaker placement, room characteristics, and personal preference. As with the Phase control, sometimes little or no difference will be heard, which is OK.

Note: For surround sound setup refer to the manual for your receiver or processor for correct Crossover settings for your system.

The Crossover control is not active when using the LFE input jack.

6 Volume

The Volume control is for matching the subwoofer speaker volume to the level of your speakers. Keep the volume low when first setting up your system and then adjust to your preferred level using different music and/or video sources. The best advice we can give on matching the volume is to adjust for the strongest bass without being "boomy".

Note: The subwoofer Volume controls the AS8 subwoofer level and does not control the subwoofer output audio level or the input level volume. The overall system volume (subwoofer + speakers) should be controlled directly from the audio source (TV, receiver, iPod, etc.).

7 Power On/Standby Indicator

This indicator LED will be GREEN when a input signal is present (music playing) and RED when no signal is present (power-saving standby mode). The AS8 subwoofer will automatically enter Standby mode after 15 minutes when no signal is detected.

8 Aux AC Outlet

9 AC Select

10 Power Switch

11 Fuse Holder

12 Power Inlet

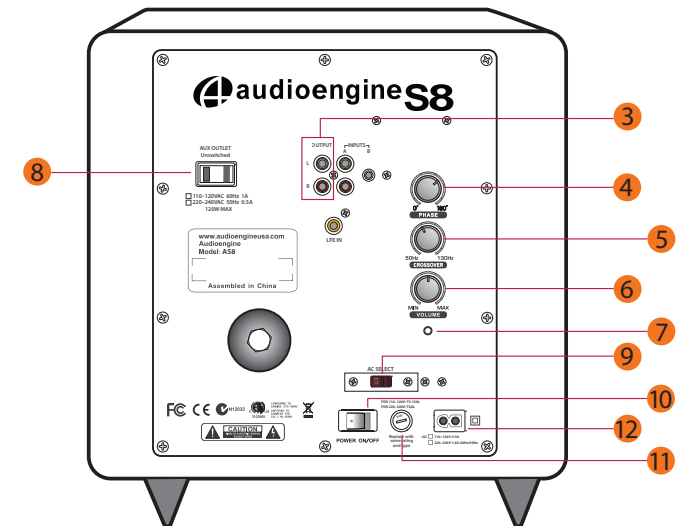



Connections

Power

- Verify that the power switch on the rear panel is in the OFF position before making any connections.
- Verify that the voltage selector switch is set to the correct operating voltage in your area.
- Connect the AC power cord to the subwoofer and the other end into a wall outlet. Do not use the outlet on the back of your Audioengine powered speakers or receiver.

Note: If using a receiver or surround sound processor always refer to the instruction manual for specific setup procedures, options, and warnings

Setup Diagrams

The diagrams that follow show the most common setup and connection options to connect your AS8 to other audio gear.

Option A

Connect a stereo RCA cable from your receiver's preamp SUB OUTPUT to the AS8 subwoofer INPUT.

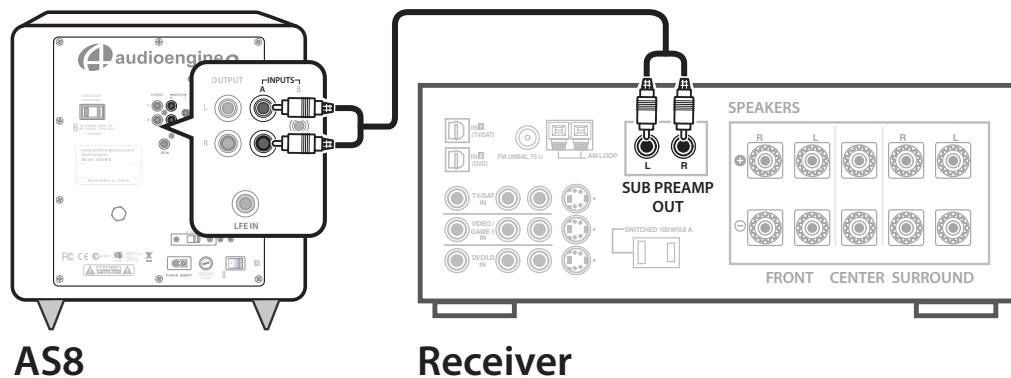

- If your receiver has a single (mono) SUB OUT, connect an RCA cable from this output to the AS8 RCA right (R) input.
- If your receiver has an LFE output, connect an RCA cable from this output to the AS8 LFE IN.

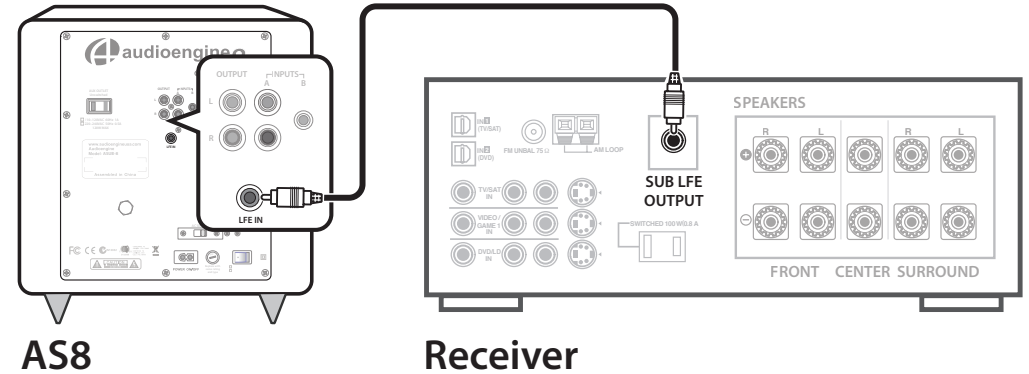

Note: Your receiver's manual should indicate which subwoofer connection is most appropriate.

Option B

Connect a mini-jack or RCA cable from any audio product (iPod, computer, CD player, TV, etc.) to one of the AS8 INPUT connectors.

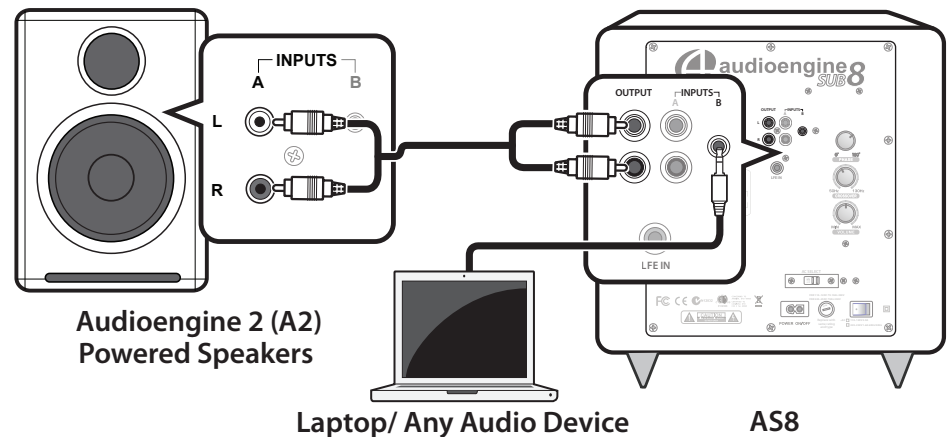



Option C

Connect a stereo RCA cable from your Audioengine 5 (A5) SUB OUT into the AS8 subwoofer INPUT

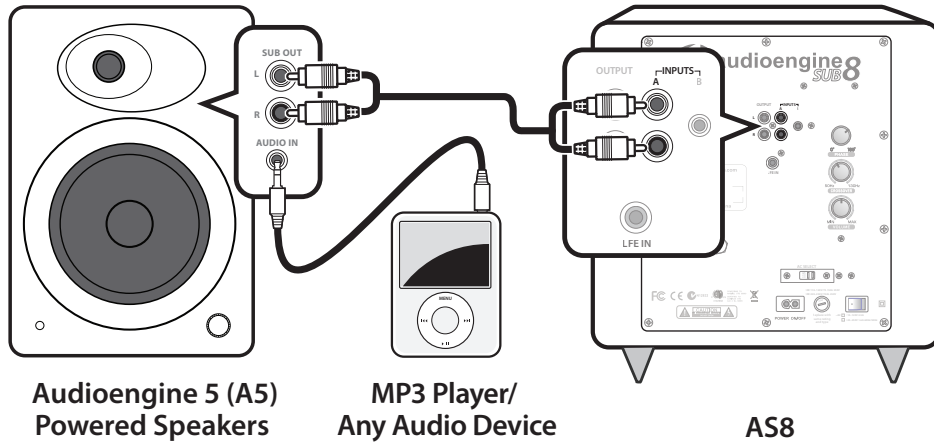

Option D

Connect a stereo RCA-to-mini "Y" adapter cable from your receiver's SUB OUTPUT into the Audioengine W1 (AW1) Wireless Sender. Then connect a mini-jack cable from the AS8 INPUT to the Audioengine W1 Wireless Receiver.

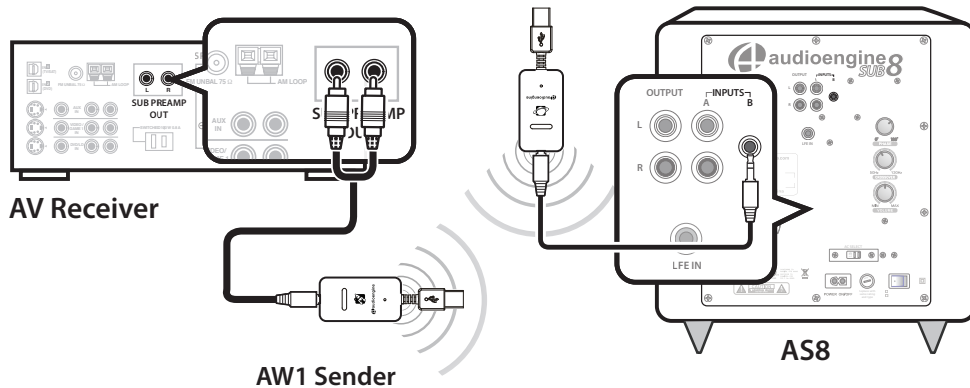

Note: The overall volume for the sub and speakers together is controlled from the input audio source.

If using the Sub Out feature on Audioengine 5 (A5) power speakers, the overall system volume (sub + speakers) is controlled directly from the audio source and not via the A5 front panel volume control.

Final Adjustments

- 1 After having connected your subwoofer in your preferred configuration, set the subwoofer volume to about 50% and turn on the power switch.
Note: Refer to the "Controls" section in this Setup Guide for more in-depth descriptions of the following settings.
- 2 Adjust the Volume level of your AS8 so that the subwoofer volume matches the overall volume of your speakers. As mentioned in the previous "Controls" section, adjust the volume for the strongest bass without being "boomy".
- 3 Fine-tune the Crossover setting by ear for the smoothest blend with your main speakers.
- 4 Adjust the Phase control for the most bass from your favorite listening position. As mentioned previously it is not uncommon for the subwoofer to sound similar at every setting, depending on your room and location of the subwoofer

There are no right or wrong settings but with these simple steps you should be up and running within a few minutes. Steps 2, 3 and 4 may require repeating in order to fine-tune to your taste.



Basic Troubleshooting

No sound from the subwoofer

If there is no sound from the subwoofer, please try the following:

LED indicator does not light up

- Check that the AC power cord is plugged in securely at both ends and make sure that the power outlet the subwoofer is connected to is working.
- Check that the power switch on the rear control panel is on.

LED indicator lights up RED but does not turn GREEN

- Recheck the connections to and from the subwoofer. Verify that the input and outputs are not accidentally swapped.
- Check that the cables from your audio source to your subwoofer are properly connected. Sometimes the 1/8" audio cables feel as if they are inserted all the way, but are not.
- Check that the volume knob on the rear panel is not set to minimum volume.
- Check that the volume level of your audio source is not set to minimum or powered off.
- If connected to a receiver or processor check settings in the bass-management menu.

LED turns green, but no sound

- Recheck the connections to and from the subwoofer.

Not enough bass from the subwoofer

If the output from the subwoofer is low, please try the following:

- Make sure that the Volume control is turned up.
- Check that the inputs and outputs are connected correctly.
- Experiment with different locations for your subwoofer.

- If your receiver has a single subwoofer connector that is not labeled LFE, make sure it connects to the subwoofer's RIGHT (mono) input connector.
- If the bass is still not enough after checking other tips use an RCA "Y" cable to connect your preamp or receiver's single output to the subwoofer's RIGHT and LEFT inputs.
- Consult your preamp processor or receiver's manual and/or on-screen menus and go through all surround sound setup and bass management options.
- If playing a movie, check the source material menu to verify that the desired soundtrack option is selected.

Note: *If your subwoofer is connected to a receiver or processor and you've tried all these tips but are still having problems, remove the AS8 from the receiver and test using an iPod, computer or other source to verify that the problem is with the subwoofer and not the receiver setup.*

Subwoofer goes into standby

If your subwoofer goes into standby while music is playing, please try the following:

- Turn the source signal up and the subwoofer volume down.
- If using with a receiver, turn the SUBWOOFER level up in the SPEAKER SET-UP menu. After you turn the signal up, turn down the volume knob on the subwoofer to compensate.

Thermal Overload

All Audioengine powered speakers and subwoofers are protected by an internal thermal sensor. If they run for extended periods beyond their designated power rating the thermal sensor will engage and shut down the amplifiers. If this occurs, turn off the power switch, lower the volume level, and wait five minutes before restarting the system. This is a normal protection feature and does not indicate a malfunction. A good tip in the unlikely event that a thermal overload occurs is to lower the subwoofer or speaker output volume and increase the volume of your input source.



Troubleshooting continued

Hum

Adding a new component such as your subwoofer can bring out hum or buzz that may not have existed before. Your first assumption may be that something is wrong with your subwoofer or other component but this is usually caused by a “ground-loop” in your system. Consider these tips for possible solutions:

- First try moving your equipment to the same electrical circuit or AC outlet.
- If the hum or buzz is still present, turn off the power on all your components in your system and remove all connections to and from the subwoofer. Plug the subwoofer AC cable back in, turn on the power switch and check for hum. If the hum is still audible then try plugging the subwoofer power cable into a different outlet.
- If the hum goes away when the interconnect cables are disconnected, the noise is likely coming from another component in your system. Add each component back one piece at a time and the one that causes the system to hum is likely the source of your noise.
- A common ground-loop source is cable TV or satellite cables. If the hum or buzz persists after trying the previous tips, disconnect the coaxial cable from your cable box, TV, or DVR and if the hum goes away the cable is the cause. In this case you can get a ground-loop isolator from Radio Shack or your local electronics store. These are inexpensive and easy to connect inline with your video cable.
- Sometimes something as simple as a portable heater or dehumidifier will add noise into your wall wiring that could be picked up by your subwoofer or powered speakers. A dimmer switch on a halogen floor lamp or a wireless internet router positioned near the subwoofer, for example, could also be possible culprits.
- The best solutions are to use an AC line filter, plug the unit into a different AC circuit, or in the case of a wireless router just physically move it further away from the subwoofer or powered speakers.

Warranty

Period

All Audioengine products have a 3-year Limited Warranty on parts and labor from date of purchase. Your warranty is automatic, so there is no need to register. This Limited Warranty applies only to Audioengine products purchased in the Continental United States. For Limited Warranty coverage elsewhere, please contact your Audioengine dealer, reseller, or distributor.

What is covered

All defective parts or faulty workmanship.

What is not covered

The Audioengine Limited Warranty does not cover damage caused by accident, misuse, abuse, neglect, excessive moisture, lightning, power surges, other acts of nature, unauthorized product modification or repairs, or failure to follow the instructions outlined in the Setup Guide.

What we will do

We will repair or replace any defective parts, at our option, within a reasonable amount of time and free of charge any time during the warranty period. After service, we will be responsible for shipping the product back to you at our expense.

What we ask from you

You will be responsible for shipping or transportation charges directly to Audioengine or to an authorized dealer. We recommend that you keep the original shipping materials, as it is important that you package the product so that it will not be damaged during shipping. Audioengine cannot be responsible for any damages incurred during shipping due to poor packing, so please pack well and make sure to insure your shipment.

How to obtain Audioengine Warranty service

If you have any questions about your warranty coverage or you think you may need service, email the Audioengine Authorized Service Center at: support@audioengineusa.com or call toll-free in the United States at: (877) 853-4447. We will do everything we can to answer your questions and resolve any issues as quickly as possible.

Exclusive Remedy

This Limited Warranty is fully transferable provided that the current owner furnishes the original proof of purchase and that furnishes the original proof of purchase and that the serial number on the product is intact. THE MAXIMUM LIABILITY OF AUDIOENGINE SHALL NOT EXCEED THE ACTUAL PURCHASE PRICE PAID BY YOU FOR THE PRODUCT. IN NO EVENT SHALL AUDIOENGINE BE LIABLE FOR SPECIAL, INCIDENTAL, CONSEQUENTIAL OR INDIRECT DAMAGES.

Product Returns and Refunds

Your satisfaction is guaranteed! Should you have a problem or are not satisfied with any Audioengine product, send us an email at: support@audioengine.com or call toll-free in the United States at: (877) 853-4447.



Audioengine S8 Premium Powered Subwoofer

General Specifications

Type:	Powered subwoofer
Power output:	250W peak power total (125W RMS), AES
Amplifier type:	Dual Class AB monolithic
Inputs:	1/8" (3.5mm) stereo mini-jack and RCA L/R
Outputs:	RCA L/R full-range
Voltages:	110-240V, 50/60Hz
Drivers:	8" (25.4cm) long-throw woofer, downfiring design
Ports:	Single, front
Signal-to-noise:	>95dB (typical A-weighted)
THD:	<0.05% at all power settings
Frequency response:	27Hz-180Hz ±1.5dB
Sensitivity:	88db SPL (1w@1m)
Input impedance:	10K ohms unbalanced
Crossover Freq:	50Hz - 130Hz
Phase:	0 - 180°
Standby power:	8W
Protection:	Output current limiting, thermal over-temperature, power on/off transient protection
Dimensions:	11.25"(H) x 11.25"(W) x 11.25"(D)
Weight:	28 lbs (12.7 kg)
Shipping weight:	30lbs (13.6 kg)
Shipping box dims:	17" (H) x 17" (L) x 17" (W)

Materials and Construction

- 1" thick MDF cabinets
- 8" custom woofer with advanced voice coil
- Toroidal power transformer

About Audioengine

Audioengine designs and builds innovative audio products with all your music in mind. Great sound, simple but elegant designs, high-quality materials, and truly useful features are what Audioengine is all about. We sincerely hope you get as much enjoyment from our products as we've had creating them! For information about our other products go to:

www.audioengineusa.com

Support

If you have any questions or feel you may need service contact the reseller where you purchased you subwoofer or feel free to email us directly at

support@audioengineusa.com

or call toll-free in the United States: (877) 853-4447