

Whirlpool® Top Load Washer

PRODUCT MODEL NUMBERS

WTW5100V, WTW5200V, WTW5300V,
WTW5505V, WTW5590V, WTW57ESV,
WTW58ESV

Electrical: A 120 volt, 60 Hz., AC only, 15- or 20-amp, fused electrical supply is required. A time-delay fuse or circuit breaker is recommended. It is recommended that a separate circuit serving only this appliance be provided.

OVERALL DIMENSIONS

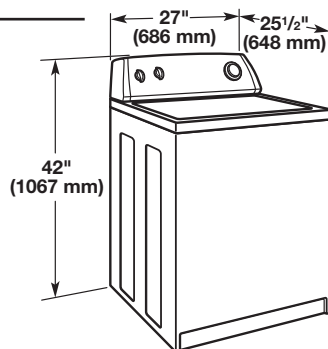

RECESSED AREA OR CLOSET INSTALLATION

For closet installation, with a door, the minimum ventilation openings in the top and bottom of the door are required. Louvered doors with equivalent air ventilation openings are acceptable.

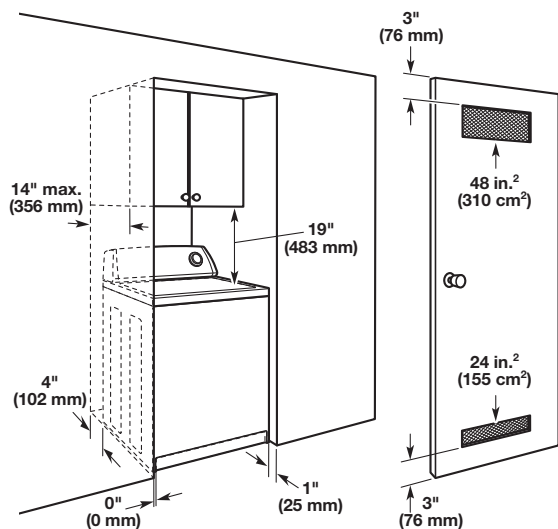

DRAIN SYSTEM OPTIONS

Wall standpipe drain system

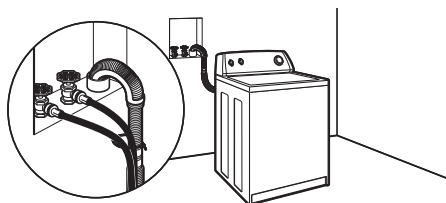

Floor drain system

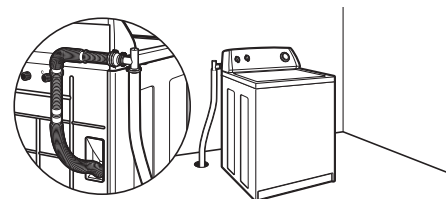

Minimum diameter for a wall or floor standpipe drain: 2" (51 mm). Minimum carry-away capacity: 17 gal (64L) per minute. Top of standpipe must be at least 39" (991 mm) high; install no higher than 96" (2.4 m) from bottom of washer. A sump pump system is required for higher installations.

Laundry tub drain system

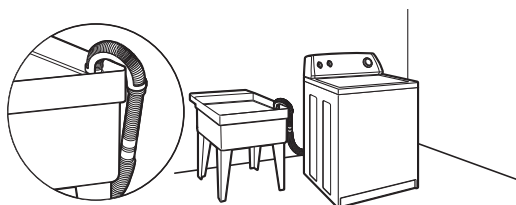

Minimum capacity: 20 gal (76 L). Top of laundry tub must be at least 39" (991 mm) above floor; install no higher than 96" (2.4 m) from bottom of washer.

Floor drain system

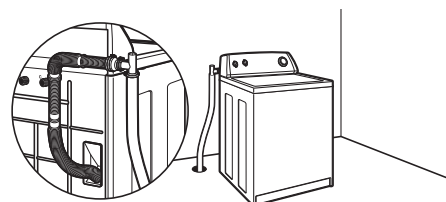

Floor drain systems require a Siphon Break Kit (Part No. 280129) and additional drain hose (Part No. 3357090). Minimum siphon break: 28" (711 mm) from bottom of washer. Additional hoses might be needed.