

Product Information Sheet

Moda
COLLECTION
by omnimount



Echo 50LE

The Limited Edition Echo Series takes 'simplicity at its best' to the next level. Furniture designed to accommodate flat panels and multiple components while still appealing to a minimalist's sense of style - in a new high gloss black finish that complements new high gloss flat panels and components. With a stunning high gloss finish, the Echo 50LE is ideal for minimalists and provides a clean, unobstructed view to showcase audio and video accessories.



The Limited Edition Echo Series features a high gloss black finish and brushed nickel accents, staying true to its simplistic roots, but with an added panache

BENEFITS

- High gloss black finish matches flat panels and components
- Open area accommodates multiple components
- Neatly route and organize wires with cable management clips
- Brushed nickel legs accent high gloss finish
- High gloss finish surrounds entire piece for placement anywhere in a room
- Rubberized feet protect floors

SPECIFICATIONS

- Accommodates up to 50" flat panels or 50" DLPs
- Top shelf supports up to 150 lbs (68 kg)
- Component shelf supports up to 80 lbs (36.3 kg)
- Dimensions: 50"w x 17.3"h x 15.5"d (1270mm x 439mm x 394mm)
- Warranty: 5 years
- Color: High gloss black

The Echo Series Limited Edition

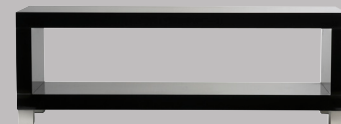

Echo 50LE

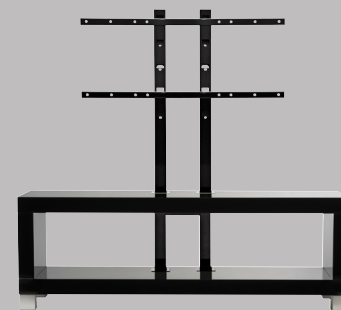

Echo 50FPLE

Echo 50LE



BENEFITS

- High gloss black finish matches flat panels and components
- Open area accommodates multiple components
- Neatly route and organize wires with cable management clips
- Brushed nickel legs accent high gloss finish
- High gloss finish surrounds entire piece for placement anywhere in a room
- Rubberized feet protect floors

SPECIFICATIONS

- Accommodates up to 50" flat panels or 50" DLPs
- Top shelf supports up to 150 lbs (68 kg)
- Component shelf supports up to 80 lbs (36.3 kg)
- Dimensions: 50"w x 17.3"h x 15.5"d (1270mm x 439mm x 394mm)
- Warranty: 5 years
- Color: High gloss black

	Color	Stock Code	Packaging UPC
Americas	HGB/B	1004587-1	728901024351
International	HGB/B	NA	NA

	inches (mm)	lbs (kg)
	54.6 x 20.6 x 10.7 (1387x524x272)	55.3 (25.1)
	NA	NA

Box Contents	Qty
Side panel	2
Top panel	1
Bottom panel	1
Foot	4

Box Contents	Qty
Rubberized foot protector	4
Hardware kit	1
Instruction manual	1

The Limited Edition Echo Series takes 'simplicity at its best' to the next level. Furniture designed to accommodate flat panels and multiple components while still appealing to a minimalist's sense of style - in a new high gloss black finish that complements new high gloss flat panels and components. With a stunning high gloss finish, the Echo 50LE is ideal for minimalists and provides a clean, unobstructed view to showcase audio and video accessories.

Echo 50LE

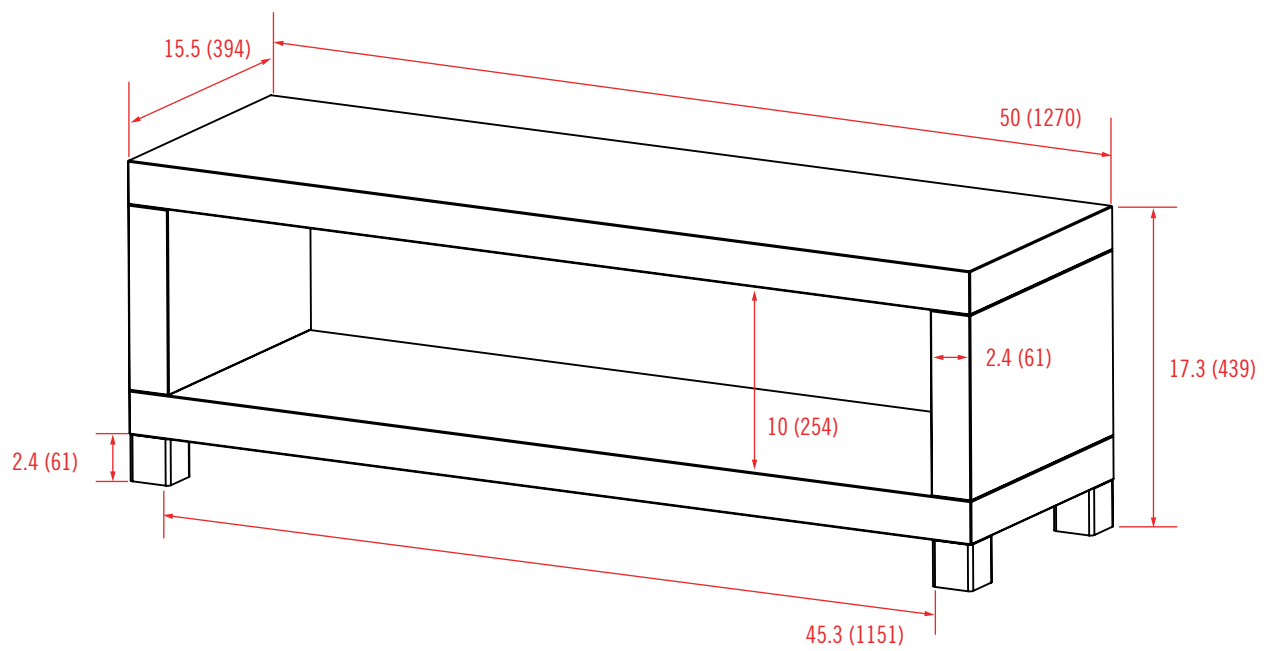

inches (mm)