

Miele

Operating and Installation Instructions

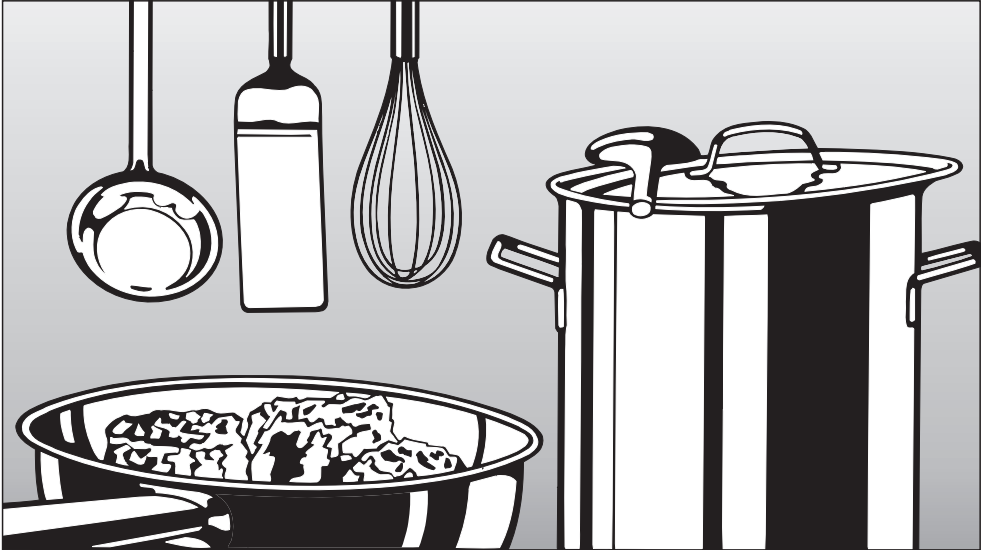

Ceramic Cooktop KM 5676

en - US, CA

To prevent accidents and
machine damage,
read the Operating Manual
before installation or use.

M.-Nr. 06 611 230

Contents

IMPORTANT SAFETY INSTRUCTIONS	3
Guide to the cooktop	8
Before using for the first time	11
Heat the cooktop	11
Touch controls	11
Resetting the touch controls	12
Use	13
Turning on the cooktop	13
Turning on a burner	13
Variable/Extended burner	13
Settings	14
Cooking with Auto-heat	15
Cooking without Auto-heat.	16
Turning off a burner	17
Turning off the cooktop	17
Residual heat indicator	17
Selecting cookware	18
Timer	20
Setting the timer	20
Setting the timer to turn off a burner automatically	21
Safety features	22
Child Safety Lock	22
Stop and Go	23
Safety cut-out feature	24
Overheating protection	25
Cooktop Settings	26
Cleaning and Care	27
Frequently asked questions	28
Technical Service	30
Installation instructions	32
IMPORTANT SAFETY INSTRUCTIONS	33
Installation	35
Electrical connection	41
Help protect our environment	42

IMPORTANT SAFETY INSTRUCTIONS

READ THE OPERATING INSTRUCTIONS CAREFULLY BEFORE USING THE COOKTOP

WARNING -

This appliance is only intended for residential cooking. The manufacturer cannot be held responsible for damage or injury caused by improper use or for uses other than those for which this appliance is intended.

When using your appliance follow basic safety precautions including the following:

Installation

Be certain your appliance is properly installed and grounded by a qualified technician in accordance with national and local safety regulations. The manufacturer cannot be held responsible for damage caused by incorrect installation or connection.

Do not connect the appliance to the main electrical supply using an extension cord. Extension cords do not meet the safety requirements of this appliance.

Before servicing, disconnect the appliance from the main power supply.

To guarantee the electrical safety of this appliance, continuity must exist between the appliance and an effective grounding system. It is imperative that this basic safety requirement be met. If there is any doubt, have the electrical system of the house checked by a qualified electrician. The manufacturer will not be held responsible for damages caused by the lack, or inadequacy, of an effective grounding system.

Only for frame/facet cooktops: A small gap will be visible between cooktop and countertop for the first days after installation. The gap will decrease as the cooktop is used. The electrical safety of your appliance is warranted despite the small gap.

Use

Do not use the appliance until it has been properly installed in the countertop.

This appliance is equipped with an overheating protection feature. See "Overheating protection" for more information.

Never use the appliance to heat a room. Due to the high temperatures radiated, objects left near the appliance could catch fire.

When the cooktop is turned on for an extended period of time, the control panel may get warm. This is not a malfunction.

IMPORTANT SAFETY INSTRUCTIONS

Injury prevention

■ Children should not be left unattended in an area where the cooktop is in use. Never allow children to sit or stand on any part of the cooktop.

Caution: Do not store items of interest to children in cabinets above the cooktop. Children climbing on the cooktop to reach these items could be injured.

■ Use the Safety Lock to prevent children from turning on the cooking zones or changing the settings. See "Safety lock" for more information.

■ Keep all pots and pans out of the reach of children. Danger of burning or scalding. Special cooktop/stove guards are available from retail outlets.

■ Do not touch the cooktop or the surrounding areas during or immediately after use. The cooktop may be hot even though it is dark in color. Wait until the residual heat indicators go out.

■ Protect your hands with insulated gloves or potholders when using the appliance. Use only dry, heat resistant potholders. Moist or damp potholders used on hot surfaces can result in steam burns. Do not let the potholder touch the hot heating elements. Do not use towels or other bulky items near the appliance.

■ Be aware of loose fitting or hanging garments when operating the cooktop, they may present a fire hazard.

■ Use the proper pan size. Select cookware with flat bottoms large enough to cover the heating element. Using undersized cookware will expose a portion of the heating element and may result in ignition of clothing or handles becoming hot. The proper size pot or pan will also improve efficiency.

■ Pot and pan handles should be turned inward and not extend over the countertop to reduce the risk of burns, ignition of flammable materials, and spills.

IMPORTANT SAFETY INSTRUCTIONS

■ Never leave a cooktop unattended at high settings or when cooking with oil or fat. Overheated oil could ignite. Always heat oil slowly, monitoring it as it heats.

■ Do not use water on grease fires. Smother or use a dry chemical or foam-type extinguisher on any fire or flame.

■ When frying food make sure that the food is as dry as possible before placing it in oil. Moisture can cause hot oil to splatter and boil over. At high settings, be cautious of splattering grease or boiling over liquids which may produce smoke.

■ Do not flambé under an exhaust hood. Flames could be drawn up into the hood by the suction and the grease filters may ignite.

■ Do not heat unopened containers. Built-up pressure may cause the container to burst and result in injury.

■ Before removing pots and pans be sure to turn off the burners.

■ To prevent burns and breathing difficulty, allow the cooktop to cool before cleaning. Some cleaners may produce toxic fumes if applied to a hot surface.

■ When wiping spills on a hot cooktop with a wet sponge or cloth, be careful to avoid steam burns.

■ Do not let flammable materials, i.e. cooking grease, accumulate on the appliance.

■ Never cover the cooktop with a cloth. A fire may result.

■ Do not store items on the cooktop when not in use. Items could melt or catch fire from residual heat or if the cooktop is turned on inadvertently.

■ Flammable materials should not be stored on or near the appliance.

■ If there is a drawer directly underneath the appliance without a protective base between it and the cooktop, ensure that no aerosols, combustible liquids or other flammable materials are kept in it. If cutlery inserts are to be placed in the drawer they must be made of heat-resistant material.

IMPORTANT SAFETY INSTRUCTIONS

Damage protection

■ Never place hot pots or pans over the touch controls, this may damage the electronics.

■ Do not drop anything on the ceramic surface of the cooktop. Even lightweight objects may cause damage.

■ Do not use pots or pans with pronounced edges or ridges on the ceramic cooktop. These could scratch the cooktop permanently. See "Selecting cookware" for more information. Grains of salt and sand can cause scratches. Make sure that the bases of any pots and pans are clean, free of any fat or oils and are dry.

■ To prevent damage to the cooktop do not use pots and pans with thin bases on the cooktop. Never heat an empty pan unless the pan manufacturer states that you can do so.

■ Before using glass, glass/ceramic, ceramic, earthenware or other glazed cookware verify that they can be used on a cooking surface.

■ Do not allow either solid or liquid sugar, pieces of plastic or foil to fall on the burners when they are hot. If these residues are allowed to cool on the ceramic surface pitting or even cracking may occur.

■ Any spills should be removed as quickly as possible to prevent them from burning on and becoming difficult to remove.

■ Do not use a steam cleaner to clean this appliance. Steam could penetrate electrical components and cause a short circuit.

IMPORTANT SAFETY INSTRUCTIONS

Appliance safety

■ In the event of any damage to the appliance, it must be turned off immediately and disconnected from the main power supply. Call Miele's Technical Service Department.

Do not use the appliance until it has been repaired. Ensure power is not supplied to the appliance until repair work is completed.

■ Do not cook on a broken cooktop. Any breakages or cracks in the ceramic surface of the appliance are defects and must be treated as such. If the cooktop should break, cleaning solutions and spills may penetrate the broken cooktop and create a risk of electric shock. Do not use the appliance until it has been repaired.

■ Repairs should only be performed by qualified technicians to ensure safety. Repairs and other work by unqualified persons could be dangerous. Under no circumstances open the outer casing of the appliance.

■ While the appliance is under warranty repairs should only be performed by an authorized service technician. Otherwise the warranty is void.

Further safety notes

■ Make certain that the power cords of small appliances do not come in contact with the cooktop. The insulation of the cable could become damaged. Danger of electric shock!

■ Do not use plastic or aluminum. They will melt at high temperatures. Fire hazard!

■ If a pet gets on the cooktop a touch control sensor could be activated turning on a burner. Keep pets away from the cooktop at all times and activate the Safety Lock.

**SAVE THESE INSTRUCTIONS
AND REVIEW THEM
PERIODICALLY**

Guide to the cooktop

Burners

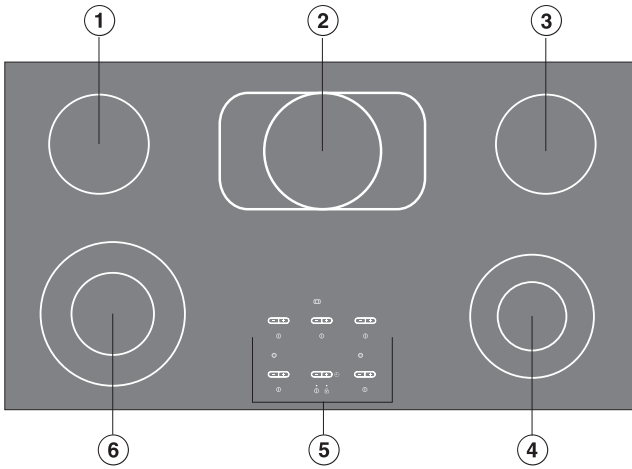

①③ Single burners

② Extended burner

④⑥ Variable burners

⑤ Controls

Touch controls/Indicators

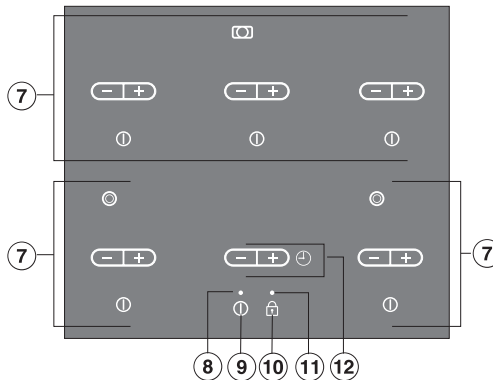

⑦ Burner controls

⑧ Cooktop ON/OFF Indicator

⑨ Cooktop ON/OFF

⑩ Child Safety Lock

⑪ Lock Indicator

⑫ Timer (see "Timer controls and display")

Burner controls and display

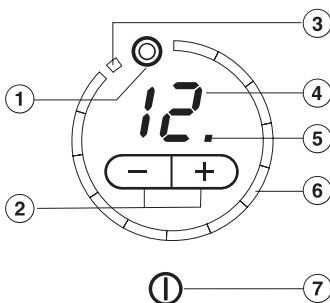

- ① Extended burner touch control
- ② Power level touch controls
- ③ Extended burner indicator
- ④ Display:
 - = Burner is ready for use
 - 0 = Burner is turned on
 - 1 to 12 = Power level
 - ≡ = Residual heat
 - F = Fault (see "Safety cut-out feature")
 - R = Auto-heat with extended range of power level
 - PD etc. = Program (see "Cooktop Settings")
 - SD etc. = Status (see "Cooktop Settings")
- ⑤ Indicator for extended power level (see "Cooktop Settings")
- ⑥ Lighting circle
 - The number of segments lit corresponds with the selected power setting (exception: see "Cooking with Auto-heat").
- ⑦ Burner On/Off touch control

Guide to the cooktop

Timer controls and display

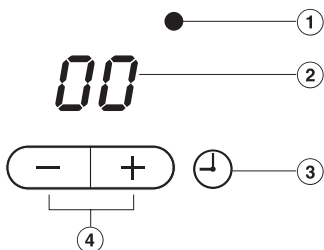

- ① Auto turn off indicator, e.g. rear right burner
- ② Time display
- ③ Touch control to turn the timer on/off, switch between functions and select a burner for auto turn off
- ④ Touch control for setting the time

Burner data

Burner	KM 5676		
	diameter in		Watts
	inches	cm	
□	5 ¹¹ / ₁₆	14.5	1100
	9 ¹ / ₁₆	23	2500
□	5 ¹¹ / ₁₆	14.5	1200
□	6 ¹¹ / ₁₆	17	1500
	6 ¹¹ / ₁₆ × 11 ⁷ / ₁₆	17 × 29	2500
□	5 ¹ / ₂	14	1200
□	4 ³ / ₄	12	700
	7 ¹ / ₁₆	18	1800
			All burners 9200

Before using for the first time

Clean the cooktop

- Before using for the first time, clean the appliance with a damp cloth and dry with a soft cloth.

Heat the cooktop

Metal components of the cooktop have a protective coating which may give off a slight odor the first time the appliance is heated.

The smell will dissipate after a short time and does not indicate a faulty connection or appliance defect.

Touch controls

This cooktop has electronic touch controls activated by a finger. A tone sounds to indicate that contact has been made with a control.

Keep the control area clean and do not rest items on it. The touch control sensors could mistake an item or debris for a finger contact, turning the cooktop on or off.

To prevent damage to the electronics never place hot pans on the control panel.

Resetting the touch controls

Automatic reset

To ensure the cooktop functions properly the touch controls will automatically reset:

- when the cooktop is connected to the electrical supply.
- if there is an interruption to the electrical supply, and
- during use in response to changing light conditions.

During the automatic reset of the touch controls the Child Safety Lock indicator illuminates and the cooktop cannot be turned on.

If the automatic reset could not be completed an **A** will light in the burner displays front left and right, and a **F** in the rear left burner display. The right rear burner display and the timer display will show numbers.

In this case the touch controls must be manually reset.

Manual reset

- Make sure no direct light (sun or artificial) beams on the cooktop. The surrounding area of the cooktop should not be completely shaded or brightly lit.
- Make sure the cooktop and the touch controls are not covered. Remove all pots and pans and clean the cooktop if necessary.
- Trip the circuit breaker to the cooktop or turn off the power main for 1 minute.

The touch controls will automatically reset when the power is restored.

If the problem persists, call Miele Technical Service.

Turning on the cooktop

- Touch the ① On/Off cooktop touch control.

A horizontal bar - will appear in each of the burner displays and the On/Off indicator lights. If no setting is chosen within a few seconds the cooktop will turn itself off as a safety measure.

Turning on a burner

- Touch the ① On/Off touch control for the desired burner.
- Select a power level between 1 and 12 by pressing the - or + sensor.

Starting the selection with - selects cooking **with** auto-heat. Starting the selection with + selects cooking **without** auto-heat.

Variable/Extended burner

When turning on a variable or extended burner the extension of the burner will automatically turn on to create a larger cooking area for pots and pans.

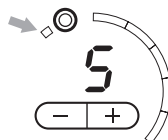

A short segment (see arrow) in the upper part of the lighting circle will indicate when the extension of the burner is in use.

Turning off the outer portion of the burner

- To turn the extension of the burner off, touch ☉.

Use

Settings

Use for	Power level*
Melting butter, chocolate, etc. Dissolving gelatin Preparing yogurt	1 - 2
Thickening sauces containing egg yolk and/or butter Warming small quantities of food/liquid Warming sticky foods Cooking rice	1 - 3
Warming liquid or half-set foods Thickening sauces, e.g. hollandaise Cooking rice pudding	3 - 5
Defrosting frozen food Steaming vegetables, fish, etc. Cooking dumplings, pasta, soups, etc. Cooking broths	4 - 6
Boiling and continued cooking of large quantities of food	7
Gentle frying (without overheating the fat) of fish, sausages, fried eggs, etc.	8 - 9
Frying pancakes, etc.	9 - 11
Boiling a large volume of water Auto-heat	11 - 12

* These settings are intended as guidelines only. When cooking with large pots, large quantities or without using a lid, a higher setting is needed. For smaller quantities select a lower setting.

Cooking with Auto-heat

When auto-heat has been activated, the burner turns on automatically at the highest setting and then changes to the continued power level which was selected. The "heat-up" time depends on which power level is chosen (see table).

If a high continued power level is selected, a shorter "heat up" time is required.

Power level	Heat up time (min : sec)
1	0 : 30
2	2 : 00
3	2 : 30
4	3 : 00
5	4 : 00
6	6 : 00
7	9 : 00
8	2 : 00
9	2 : 00
10	2 : 30
11	2 : 30
12	-

To activate auto-heat

- Turn the burner on.
- Touch the - sensor until the desired power level is displayed, e.g. 3.

12 segments will light in the lighting circle during the auto-heat time. After the auto-heat time has elapsed only the number of segments will light which correspond to the selected power level.

Example:

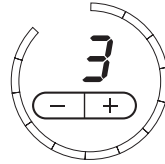

during Auto-heat.

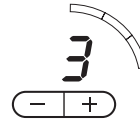

during the continued cooking time.

The continued power level can be increased or decreased during the heat up phase with the **-/+** controls. The heat up time will change accordingly.

Use

Cooking without Auto-heat

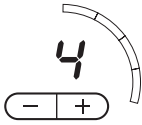

- Turn the burner on. Touch the **+** sensor until the desired power level is displayed, e.g. **4**.

Additionally the power level is indicated by the number of segments in the lighting circle. For example: Power level **4** shows four segments.

Turning off a burner

- Touch the ① On/Off touch control for the desired burner.

The display will show - for a few seconds. If the burner is still hot, the residual heat indicator will show.

Turning off the cooktop

- Touch the ① On/Off touch control for the cooktop.

All burners are turned off. For the burners which are still hot the residual heat indicator will show in the respective display.

Residual heat indicator

The bars in the residual heat indicator go out one after another while the burner cools. The last residual heat indicator will go out when the burner is cool enough to touch.

Do not touch the burner or rest any objects on the cooktop when the residual heat indicator is on. Danger of burns!

After a power failure the residual heat indicator will flash.

Caution: If there is a fault, the residual heat indicator will not light even if the burners are still hot.

Cooking can be completed using the residual heat of the burners by turning the cooktop off 5 minutes before the food is finished.

Selecting cookware

Following these tips will allow you to make the most of your ceramic cooktop.

The cooking surface

The ceramic cooktop is made of an extremely hard and durable material. The surface is scratch resistant, not scratch proof. Avoid using cookware with ridged bottoms. Ridged pots with dirty or chipped enamel bottoms may scratch the cooktop if they are pulled across the ceramic surface.

Make sure the cooktop and pot bottoms are clean before cooking. Certain items, particularly sugar grains or crystallized liquids such as molasses or syrups are harder than ceramic and can scratch the surface if they are not cleaned off immediately. Small or light scratches will not affect the safety or performance of the cooktop.

The burner rings and touch controls are fused into the ceramic glass and are resistant to wear if properly maintained. Do not use abrasive cleaners or pads, as they may eventually wear off the rings.

Pots and pans

Special cookware is not required, but as is true with all types of cooking appliances, the better the cookware, the better the performance.

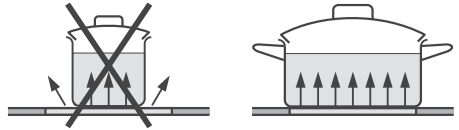

- For the most even and energy efficient cooking, the diameter of the pots/pans should match the diameter of the burners as closely as possible.

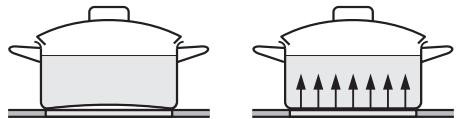

- Use cookware with thick, flat, smooth bottoms. Slightly concave bottoms will also work adequately. Pots with convex bottoms will not cook well.

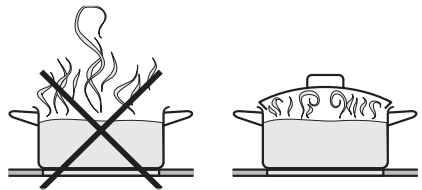

- Using a lid while cooking will minimize the loss of heat and decrease the cooking time.

Copper bottom and aluminum pans

may leave a residue on the cooktop in the form of metallic lines. This is normal. These lines can be removed using a non-abrasive ceramic cooktop cleaner or a shielded scraper blade.

Be sure to clean the cooktop after each use. Each time this residue is allowed to melt it becomes harder to remove and may mar the appearance of the cooktop. Let the cooktop cool before cleaning.

Cast iron, glass or stoneware should not be used because they have poor heat transfer and may scratch the cooktop surface.

Timer

The cooktop has a timer which can be used to time activities in the kitchen and/or automatically turn off the burners. Both functions can be used simultaneously.

A time between **1** and **99** minutes can be set. The time can be decreased or increased with the **-** or **+** touch control. To set the display back to **00** press **-** and **+** at the same time.

If multiple times are programmed, the time which elapses first is displayed. If this time is allocated to a burner, the respective indicator will flash.

Setting the timer

The timer can be set with the cooktop either on or off. The timer can be set from 1 to 99 minutes.

- Touch the  sensor.

To set the timer when the automatic turn off is programmed for one or more burners: Press the sensor  until all indicators of the programmed burners light steadily and the display shows **00**.

The display shows **00**.

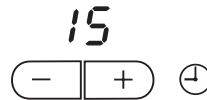

- Touch the **-** or **+** sensor until the desired time is displayed, e.g. 15 minutes.

The set time counts down in minutes in the time display. The remaining time is displayed and can be changed at any time by pressing **-** or **+**.

After the set time has elapsed the display shows **00** and a tone is heard. After a few seconds the tone stops and the **00** goes out. To end the tone touch the  sensor.

Setting the timer to turn off a burner automatically

To use this feature, a power setting must be selected for the desired burner. All burners can be programmed at the same time.

- Turn the desired burner on, e.g. rear right, and select a power level.
- Touch the ⊕ sensor until the indicator of the desired burner lights, e.g. rear right.

If multiple burners are turned on, the indicators for the activated burners light clockwise from front left to front right.

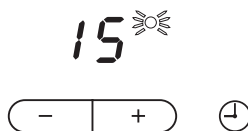

- Touch the - or + sensor until the desired time is displayed, e.g. 15 minutes.

The set time counts down in minutes. The remaining time is displayed and can be changed at any time by pressing - or +.

When the set time has elapsed the burner will automatically turn off. The burner display shows 0, the timer display shows 00 and a tone is heard. After a few seconds the tone stops and the 00 goes out. To end the tone touch the ⊕ sensor.

Safety features

Child Safety Lock

Keep children away from the cooktop for their own safety.

The cooktop has a Child Safety Lock to prevent children from turning on the burners or changing the settings.

The Child Safety Lock can be activated while the cooktop is on or off.

Activating the Child Safety Lock during cooktop use

- The settings for the burners and for the timer cannot be altered.
- The burners and cooktop can still be turned off but once turned off cannot be turned on again.

Activating the Child Safety Lock when the cooktop is turned off

- The cooktop cannot be turned on.

To activate the Child Safety Lock

- Press and hold the  Child Safety Lock control until the respective indicator lights.

The indicator will go out after a short time.

If you touch the  Child Safety Lock control or select a setting, the indicator will come on again to show that the Child Safety Lock has been activated.

To deactivate the Child Safety Lock



- Press and hold the  Child Safety Lock control until the indicator goes out.

In the case of a power failure the Child Safety Lock will be deactivated.

Stop and Go

Stop and Go is a feature which reduces the power of all turned on burners. The cooktop can be left for a short time without supervision and the danger of boilovers.

To activate Stop and Go

- Press and hold the  Lock control until you hear two audible signals in quick succession. Do not touch the  Lock control too long or the Safety Lock will be activated.

The safety lock indicator will flash. The power for the activated burners is now reduced to power level 1. The respective burner will display 1.

If the automatic turn off function is programmed for a burner, the time will be interrupted when activating "Stop and Go". The time will continue when "Stop and Go" is deactivated.

To deactivate Stop and Go

- Press and hold the  Safety Lock control until the indicator goes out.

The burners will now operate with the last selected power level.

Safety features

Safety cut-out feature

The cooktop is on too long

The cooktop has a safety cut-out feature in case it is not turned off after use.

If one of the burners is heated for an unusually long period of time (see table), and the power level settings are not adjusted, the cooktop will turn itself off automatically and the residual heat indicator will light.

Power level*	Maximum operating hours
1/1.	10
2/2.	5
3/3.	5
4/4.	4
5/5.	4
6	4
6.	3
7/7.	3
8/8.	3
9/9.	2
10/10.	2
11/11.	2
12	1

* The power level with period are only available when the range is extended, see "Programming".

- If you wish to use the burners once again, turn the cooktop on in the usual way.

Covered touch controls

The cooktop will turn off automatically if any of the touch controls are covered for more than 10 seconds, e.g. by finger contact, food boiling over or by an object such as an oven mitt or towel. A tone will also sound every 30 secs. for a maximum of 10 min and the display will show a flashing **F**.

- Clean the touch controls or remove the object covering it.



This will turn off the signal tone and the displayed **F** will go out.

- Turn the cooktop on again with the ① touch control. The burners can now be used.

Overheating protection

Each burner is equipped with a temperature limiter. This limiter turns off the heating elements in the burner before the ceramic surface becomes too hot. Once the ceramic surface has cooled to a safe temperature the heating elements will automatically turn back on.

The overheating protection may be activated by:

- turning on a burner without putting a pan on it.
- heating an empty pan.
- an uneven pan not sitting evenly on the burner.
- the pan not conducting heat properly.

If the heating elements cycle on and off, even at the highest setting, the overheating protection has been activated.

Cooktop Settings

The following default cooktop settings of the cooktop can be reprogrammed if needed:

- Auto-heat settings
- Default power
- Demo mode
- Power level range
- Residual heat indicator
- Safety lock
- Stop and go
- Timer function
- Timer start setting
- Timer tone
- Tone for touch controls
- Automatic turn on of outer portion variable/extended burner

If you would like to reprogram the settings of your cooktop, please contact Miele for assistance.

Do not use a steam cleaner to clean this appliance. Steam could penetrate electrical components and cause a short circuit. Pressurized steam could cause permanent damage to the surface and to components for which the manufacturer cannot accept responsibility.

Do not use any sharp pointed objects which could damage the seal between the ceramic surface, the surrounding frame and the countertop.

Never use abrasive cleaners, caustic (oven) cleaners, dishwasher detergent, scouring pads, steel wool or hard brushes. They will damage the surface.

The ceramic surface can be cleaned using a cleaner for ceramic surfaces. Follow the manufacturer's instructions.

Make sure that no cleaner residue remains on the ceramic surface by carefully wiping the cooktop with a damp cloth. They may damage the cooktop or produce toxic fumes when heated.

Be sure that pot and pan bases are clean and dry.

After cleaning dry the ceramic surface with a soft cloth to prevent a build up of limescale deposits.

Clean any spills immediately before they become difficult to remove.

Clean the appliance regularly, preferably after each use. Allow the appliance to cool before cleaning.

- Wipe off any soiling using a damp cloth. Stubborn soiling is best removed with a shielded scraper blade.
- Apply a ceramic cleaner using a soft cloth or paper towel. To remove any limescale deposits or metallic residue apply a ceramic cleanser using a soft cloth or use a shielded scraper blade if necessary.
- After cleaning wipe the ceramic surface with a damp cloth and dry.

A cleaner with a special additive to prevent water marks and smears on the ceramic surface may be used.

Any melted solids like **sugar, plastic or aluminum foil** should be removed as soon as possible, while the burner is still warm. If they are allowed to harden the cooktop may become pitted.

- Turn the burner off.
- Using a shielded scraper blade, scrape the melted item **immediately** off the burner while it is still hot. Use caution: Danger of burns!
- Allow the cooktop to cool and clean as previously described.

Frequently asked questions

 Repairs should only be carried out by an authorized technician in accordance with local and national safety regulations. Unauthorized repairs could cause injury or appliance damage. The manufacturer cannot be held responsible for unauthorized work.

What if the cooktop or the burners cannot be turned on?

Possible fault	Fix
The Safety Lock is activated.	Deactivate the safety lock. See "Safety lock".
The main fuse has blown.	Check the main fuse.

What if the burner does not heat up but can be turned on and a power level can be selected?

Possible fault	Fix
The cooktop is in the demo mode.	Call Miele Technical Service.

What if the cooktop turns off during use, a tone sounds and the residual heat indicator or a flashing *F* appears?

Possible fault	Fix
The burner was on for too long or the touch controls are covered.	See "Safety cut-out feature".

What if a heating element turns off then on again?

Possible fault	Fix
The overheating protection has activated.	See "Overheating protection".

What if food does not cook when using auto-heat?

Possible fault	Fix
The pot or pan does not transfer heat properly.	Use the correct pots and pans, see "Selecting cookware".
Large amounts of food are cooked.	Select a higher continued power level.

Frequently asked questions

What if one or more residual heat indicators flash?

Possible fault	Fix
There was a power failure during use. The burners are turned off.	Turn the cooktop on as usual.
The residual heat indicators were lit while the programming mode, e.g. Safety Lock, was selected.	The residual heat indicators will flash for about 45 minutes after leaving the programming mode. The cooktop can be used as usual.

What if when the cooktop is turned off, the timer display shows numbers and the burner displays show *R*, *F* or numbers?

The touch controls could not be reset automatically. They must be reset manually.

See, "Resetting the touch controls - Manual reset".
If the problem persists, call Miele Technical Service.

What if the rear burner display shows *F*, the front burner display shows *E* and the timer shows numbers?

Possible fault	Fix
Trip the circuit breaker to the cooktop or disconnect the appliance from the main power supply for 1 minute.	If the problem persists, call Miele Technical Service.

Technical Service

In the event of a fault which you cannot easily fix yourself, please contact the Miele Technical Service Department at the address on the back of this booklet.

When contacting Technical Service please quote the serial number and model of the cooktop. This information is visible on the silver data plate supplied with the cooktop.

Adhere data plate sticker here:

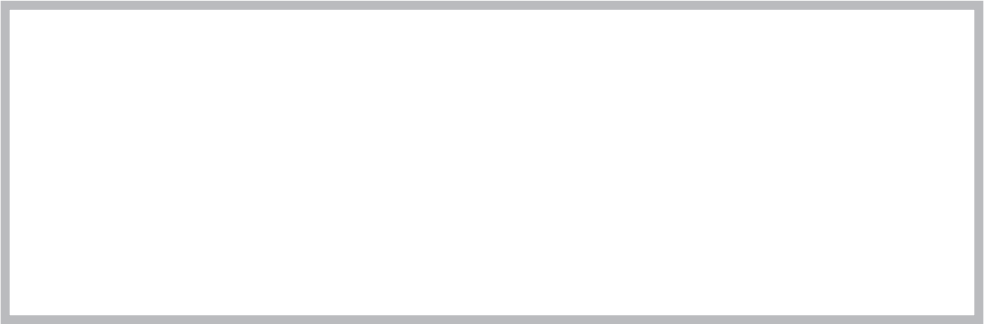

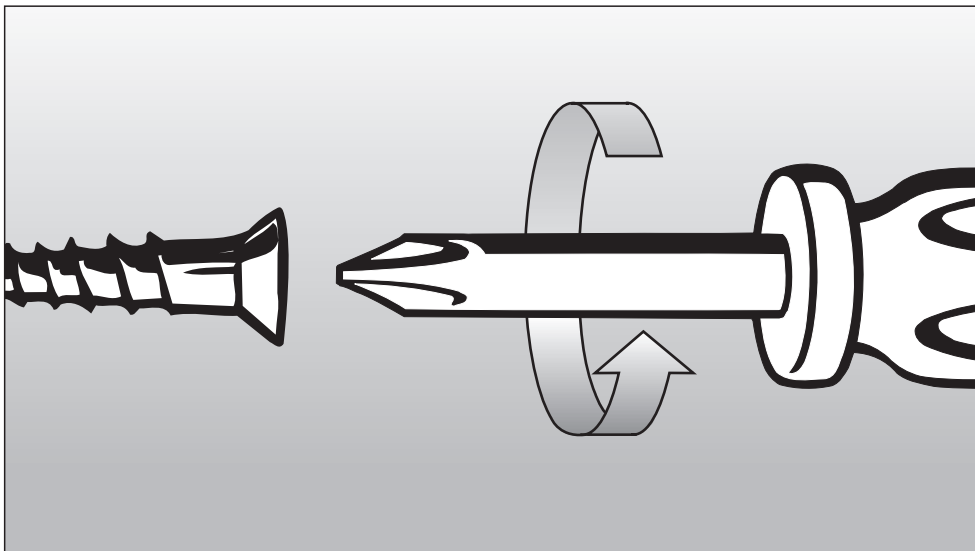

Installation Instructions

To prevent accidents
and machine damage
read these instructions
before
installation or use.

IMPORTANT SAFETY INSTRUCTIONS

Note to the installer:

Please leave this instruction book with the consumer for the local electrical inspector's use.

The minimum distances given in these Installation Instructions must be observed in order to ensure safe operation. Failure to do so increases the risk of fire.

The cabinetry and venting hood should be installed first to prevent damage to the cooktop.

The cooktop should only be installed as shown in the illustrations while maintaining the required safety distances shown. Do not install the cooktop between two tall cabinets, this is a fire hazard.

A minimum distance of 2" (50 mm) from the cooktop to the rear wall and a side wall must be maintained for safety.

The countertop must be bonded with heat resistant (212 °F/100 °C) adhesive to prevent distortion or dissolving.

The cooktop must not be installed over a dishwasher, washer, dryer, refrigerator or freezer. Heat radiated by the cooktop may damage them.

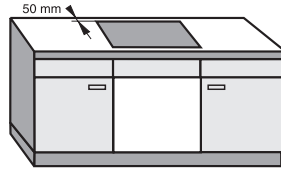
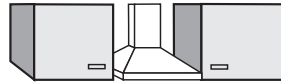

recommended

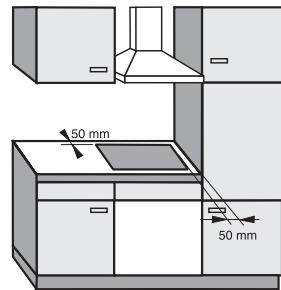

not recommended

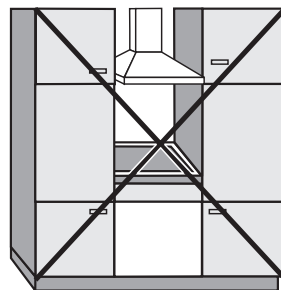

not allowed

IMPORTANT SAFETY INSTRUCTIONS

To eliminate the risk of burns or fire by reaching over heated surfaces cabinet storage space above the cooktop should be avoided. If cabinet storage is necessary, the risk can be reduced by installing a venting hood to project horizontally a minimum of 5" beyond the bottom of the cabinets.

Because of the heat radiated it is not recommended to install the cooktop above a drawer. It should be installed above a cabinet base unit with a dummy drawer front. A protective base should also be installed between the dummy drawer and the cooktop.

This appliance has not been designed for maritime use or for use in mobile installations such as recreational vehicles or aircraft. However, under certain conditions it may be possible for installation in these applications. Please contact the Miele Technical Service Department with specific requirements.

The cooktop must not be permanently sealed into the countertop when installed. The sealing strip under the edge of the cooktop provides a sufficient seal for the countertop. See "Sealing".

Safety distances above the appliance

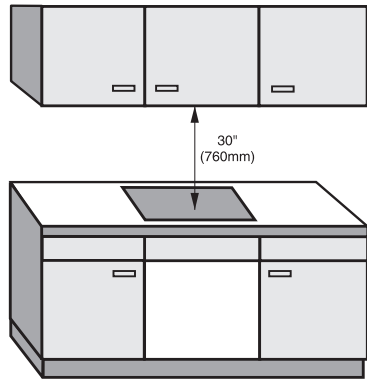

As a general rule there must be a safety distance of at least 30" (760 mm) between the appliance and any objects above it, e.g. cabinetry, venting hood, etc. If the manufacturer of these items states a different figure, always adhere to the greater distance. Their measurements should be given in their operating and installation instructions.

If there is more than one appliance beneath a hood, e.g. wok burner and electric cooktop, and they have different minimum safety distances always select the greater distance.

Installation

Cooktops flush with the countertop

Frame/Facet cooktops

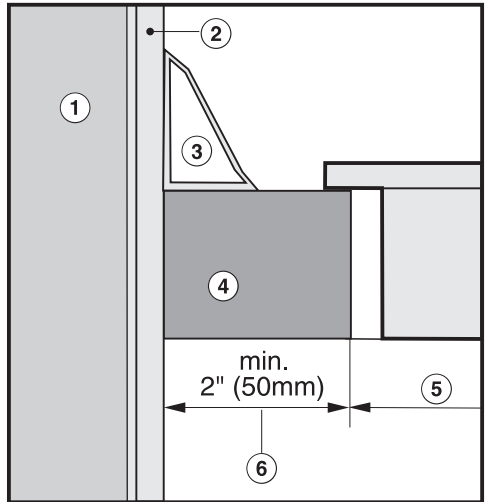
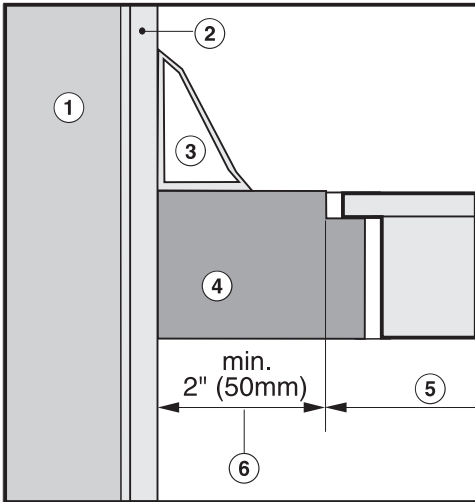

- ① Wall
- ② Wall covering
- ③ Back splash strip
- ④ Countertop
- ⑤ Countertop cut-out
- ⑥ 2" (50 mm) minimum distance

Installation dimensions

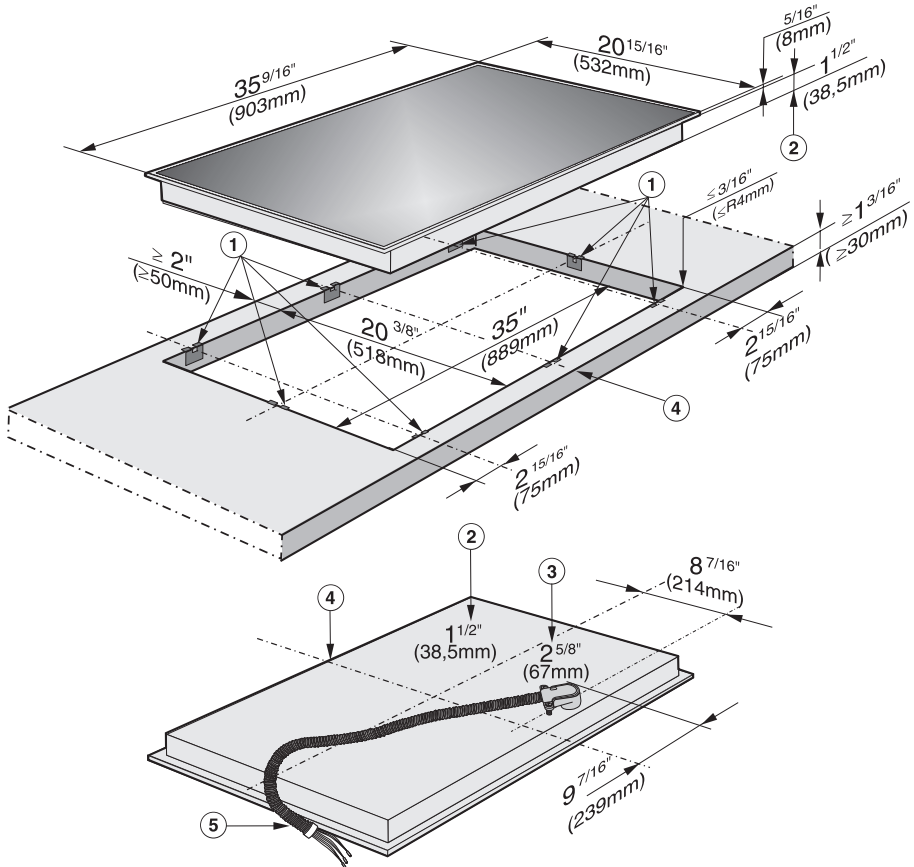

- ① Spring clips
- ② Installation height
- ③ Installation height power supply line
- ④ Front
- ⑤ Flexible stainless steel hose
Length = 3' 11" (1200mm)

Installation

Cut out

- Make the countertop cut-out following the dimensions given in the illustration.

Remember to maintain a minimum distance of 2" (50 mm) between the rear wall and the right or left side. See also "IMPORTANT SAFETY INSTRUCTIONS".

- Seal the cut surfaces with a suitable sealant to avoid swelling caused by moisture. The materials used must be heat resistant.

If during installation the seal around the frame does not sit flush with the countertop in the corners, the corner radius, maximum $\frac{3}{16}$ " (4 mm), can be carefully filed down to fit.

Installing the spring clips

Wood or corian countertops

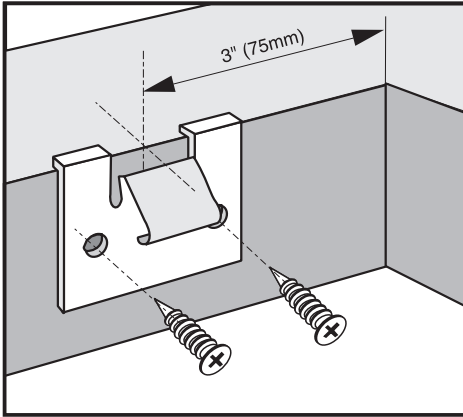

- Fix the supplied spring clips at the marked positions as shown above, by laying them on the upper edge of the cut-out and then securing them with the $\frac{1}{8}$ " x 1" (3.5 x 25 mm) screws supplied.

Granite countertops

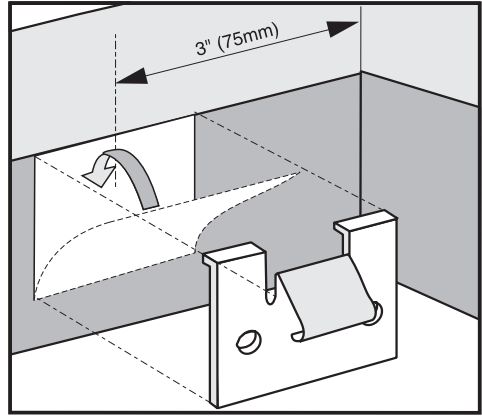

- For granite countertops, the spring clips must be placed in position and secured with strong, double-sided adhesive tape.

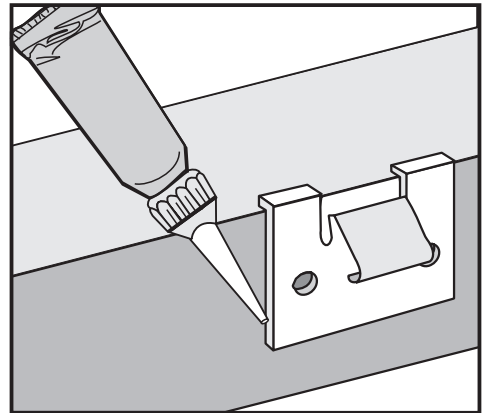

- In addition, coat the edges of the spring clips with silicone sealant.

The screws are not needed for granite countertops.

Installation

Installing the cooktop

- Feed the power cord down through the cut-out and connect the appliance to the power supply.
- Position the cooktop on the spring clips, ①.
- Then with a hand on each side of the cooktop press down evenly on the edges until it clicks into position. When doing so make sure that the cooktop seal sits tightly on the countertop to ensure it is sealed correctly.

The cooktop can now only be removed with a special tool.

- Connect the cooktop to the main power supply.
- Turn the cooktop on and check the function.

Wooden countertop

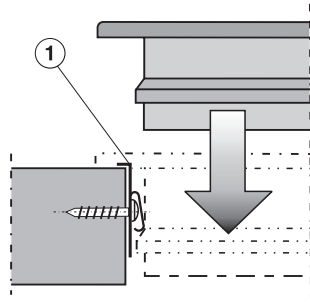

Granite countertops

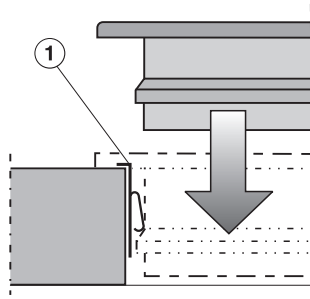

Protective bottom plate

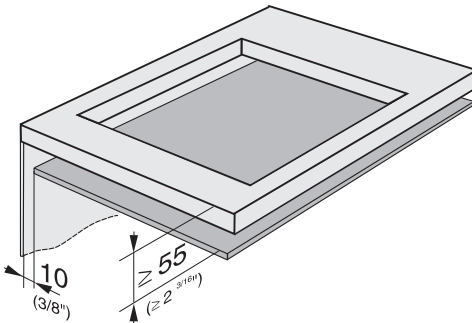

The cooktop bottom must be installed in such a way that the bottom is shielded and cannot be touched.

A wooden base and front cover must be installed if:

- no oven is installed underneath.
- the cooktop is larger than the oven or control unit underneath.
- the cooktop and the oven underneath are built in staggered.

The minimum distance from the top edge of the countertop to the wooden base must be $2 \frac{3}{16}$ " (55 mm).

Between the base and the back panel there must be an air gap of $\frac{3}{8}$ " (10 mm).

Sealing

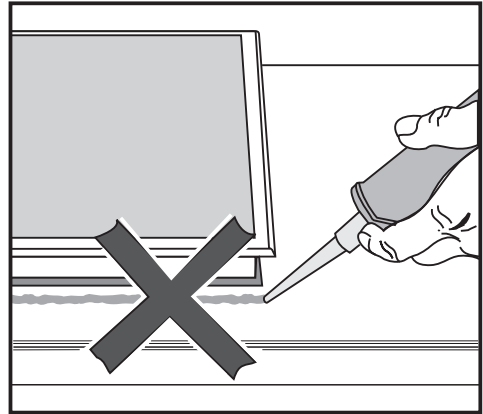

The cooktop must not be permanently sealed into the countertop when installed. The sealing strip under the edge of the cooktop provides a sufficient seal for the countertop.

If the cooktop is sealed into position, the countertop or appliance could be damaged if the cooktop needs to be removed for maintenance or service.

Electrical connection

 **CAUTION:** Before installation or servicing, disconnect the power supply by either removing the fuse, shutting off the power main or manually "tripping" the circuit breaker.

Installation work and repairs should only be performed by a qualified technician in accordance with all applicable codes and standards. Repairs and service by unqualified persons could be dangerous and the manufacturer will not be held responsible.

Before connecting the appliance to the power supply, make sure that the voltage and frequency listed on the data plate correspond with the household electrical supply. This data must correspond to prevent appliance damage. Consult an electrician if in doubt.

Only operate the cooktop after it has been installed into the countertop.

Installer:

Please leave these instructions with the consumer.

Power supply

- Make sure your electrical supply matches the data plate.

Connection

The cooktop is equipped with a flexible power cord consisting of 3 wires ready for connection to a grounded power supply.

208 V, 60 Hz, 50 A fuse rating.
240 V, 60 Hz, 40 A fuse rating.

Black wire: connect to L1 (hot)
Red wire: connect to L2 (hot)
Green wire: connect to GND (ground)

A dedicated line and junction box should be used to connect the cooktop to a 50 A circuit (208 V model) or to a 40 A circuit (240 V model).

For further information, see the wiring diagram provided with the appliance.

 **WARNING:**
THIS APPLIANCE MUST BE GROUNDED!

Disposal of packing materials

The cardboard box and packing materials are biodegradable and recyclable. Please recycle.

Ensure that any plastic wrappings, bags, etc. are disposed of safely and kept out of the reach of children.
Danger of suffocation!

Disposal of an old appliance

Old appliances contain materials that can be recycled. Please contact your local recycling authority about the possibility of recycling these materials.

Before discarding an old appliance, disconnect it from the electrical supply and cut off the power cord to prevent it from becoming a hazard.

When contacting the Technical Service,
please quote the model and serial number
of your appliance.



Miele, Inc. (USA)

National Headquarters

9 Independence Way
Princeton, NJ 08540
Phone: 800-843-7231
609-419-9898
Fax: 609-419-4298
www.miele.com

**Technical Service & Support
Nationwide**

Phone: 800-999-1360
Fax: 888-586-8056

Miele Limited (CDN)

Headquarters and Showroom

161 Four Valley Drive
Vaughan, ON L4K 4V8
Phone: 800-643-5381
905-660-9936
Fax: 905-532-2290
www.miele.ca
info@miele.ca (general enquiries)
professional@miele.ca (commercial enquiries)

MieleCare National Service

Phone: 800-565-6435
905-532-2272
Fax: 905-532-2292
service@miele.ca (technical enquiries)