

L65-A90

1080p LaserVue™ TV



OVERALL DIMENSIONS (Approx.)

Height	Width	Depth	TV Weight	Power Consumption
39.8"	57.7"	12.5"	136.4 lbs	135 W

BACK PANEL

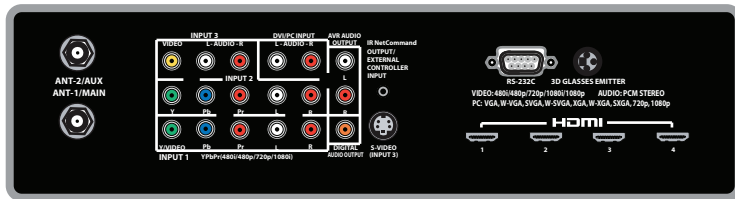

TOP

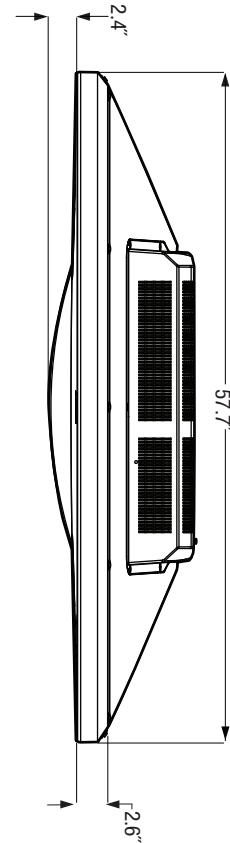

FRONT

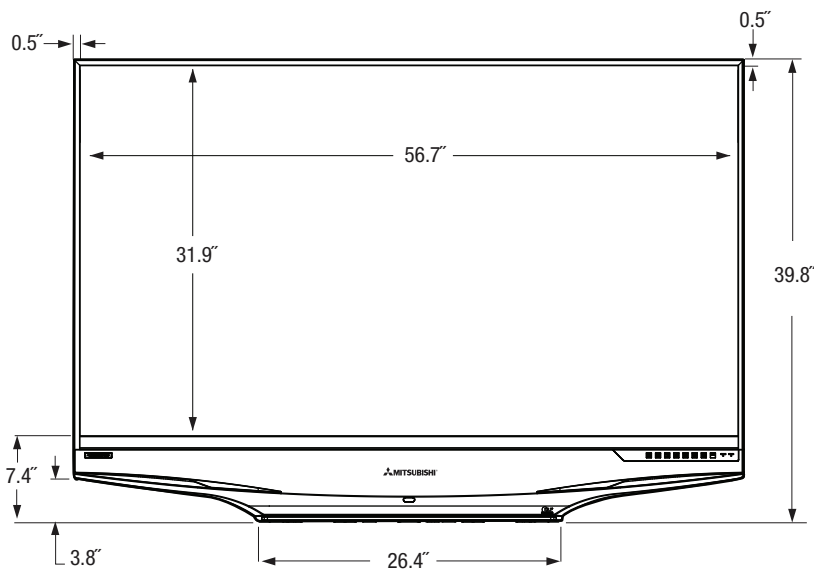

LEFT SIDE

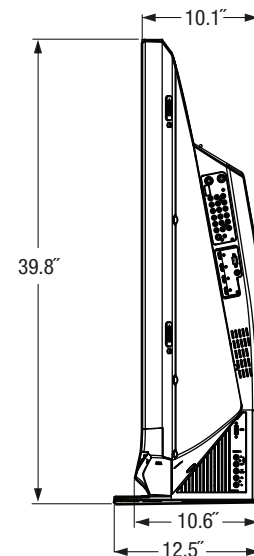

Note: Illustrations not necessarily to scale. Descriptions and specifications subject to change without notice. The dimensions are approximate for general information when deciding the locations and placements of the product. When creating a custom-built environment for this product, please take exact measurements from the specific unit to be installed before doing any finished carpentry. When installing the unit, allow for air circulation, ventilation, and variations due to manufacturing tolerances. The cosmetic appearance of the product may vary from that depicted here. Not responsible for typographical or printed errors.

CLASS 1 LASER PRODUCT

Complies with FDA performance standards for laser products except for deviations pursuant to Laser Notice No. 50, dated June 24, 2007.