

Use and Care Manual Epicure[®] Outdoor Grill

Covers Models: OB36, OBS36,
OB52, OBS52,
OBSB162

SAFETY IS EVERYONE'S RESPONSIBILITY. ALL DACOR[®] APPLIANCES ARE DESIGNED AND CONSTRUCTED TO GIVE YOU MANY YEARS OF SAFE OPERATION. THE OPERATION WILL BE FURTHER ENHANCED IF PROPER CARE AND JUDGEMENT ARE EXERCISED IN THE USE AND MAINTENANCE OF THIS APPLIANCE.



WARNINGS:

Must be followed carefully to avoid personal injury or damage.



NOTES:

Contains helpful hints and tips.

IMPORTANT INFORMATION

- **Operating Instructions**
- **Care and Cleaning Instructions**
- **Safety Tips**

Please Read Before Using Your Outdoor Grill

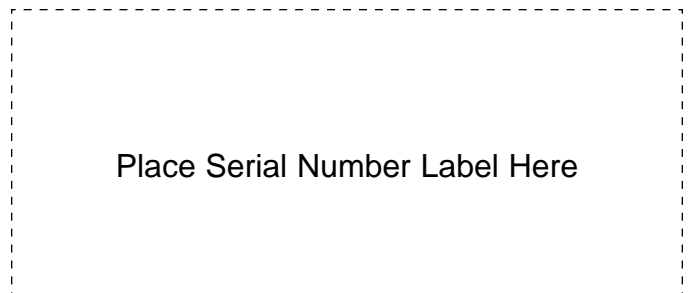



To Our Valued Customer:

Congratulations on your purchase of the very latest in Dacor® products! Our unique combination of features, style and performance make us The Life of the Kitchen™, and a great addition to your home.

In order to familiarize yourself with the controls, functions, and full potential of your new Distinctive Appliance, we suggest that you thoroughly read this use and care manual, beginning with the **Important Safety Instructions** section.

All Dacor appliances are designed and manufactured with quality and pride, while working within the framework of our company value. Should you ever experience a problem with your product, please first check the **Before You Call for Service** section of this manual for guidance. It provides useful suggestions and remedies prior to calling for service.

Valuable customer input helps us to continuously improve our products and services, so please feel free to contact our Customer Service Team for assistance with any of your product support needs.

Dacor Customer Service Team
1440 Bridge Gate Drive
Diamond Bar, CA 91765

Telephone: (800) 793-0093
Fax: (626) 403-3130
Hours of Operation: Monday through Friday
6:00 A.M. to 5:00 P.M. Pacific Time
Web Site: www.Dacor.com

Thank you for choosing Dacor for your home. We are a company built by families for families and we are dedicated to serving yours. We are confident that your new Dacor product will deliver a high level of performance and enjoyment for many years to come.

Sincerely,

Cheryl Crowe
Director, Customer Satisfaction

TABLE OF CONTENTS	1
Purpose of this Manual	1
IMPORTANT INSTRUCTIONS	1
IMPORTANT INFORMATION	1
GRILL OPERATION	2-5
Safety.....	2
Liquid Propane Tanks.....	2
Grill/Cart Features.....	2-3
Install Liquid Propane Tank.....	3
Lighting Liquid Propane Grills	4
Lighting Natural Gas Grills	4
Manual Lighting.....	4
Canopy Mounted Temperature Gauge.....	4
Preheating Instructions	4
Grill Cooking.....	5
Smoker Cooking.....	5
Rotisserie Cooking.....	5
Side Burners	5
CARE AND CLEANING	6
Cleaning Tips	6
CLEANING EXTERIOR SURFACES	6
CLEANING INTERIOR SURFACES	6
BEFORE YOU CALL FOR SERVICE	7
Troubleshooting	7
Product Maintenance	8
If You Need Service.....	8
PRODUCT WARRANTY	8
What Is Covered	8
What Is Not Covered.....	8

Purpose of This Manual

This **Use and Care Manual** is designed to enable you to properly operate and maintain your new grill. Please keep this manual handy for easy access and quick reference.

Additional information may be requested by e-mailing, writing or phoning the Dacor Customer Service Team. The address and phone number of this department are listed on the inside front cover of this manual.

Important Safety Instructions

WARNING:

NEVER use this appliance as a space heater to heat or warm the room. Doing so may result in carbon monoxide poisoning and overheating of the appliance.

WARNING:

1. If the information in this manual is not followed exactly, a fire or explosion may result causing property damage, personal injury or death.
2. Do not store or use gasoline or other flammable liquids in the vicinity of the appliance. Keep aerosol cans away from the appliance.

Important Information

Please enter the information in the spaces provided below for future use. This information will be required in the unlikely event that a service call becomes necessary:

Model No. _____ Serial No. _____
 Date Purchased _____ Date Installed _____
 Purchased From _____

3. If you smell gas:
 - Shut off gas to the appliance.
 - Extinguish any open flame.
 - Open the grill lid.
 - If odor continues, from a neighbor's phone, immediately call your gas supplier.
 - If you cannot reach your gas supplier, call the fire department.
4. Installation and service must be performed by a qualified installer, service agency or the gas supplier.
5. This unit is for outdoor use only in a well-ventilated area. Not to be used in a building, garage or any other enclosed area.
6. Tested in accordance with ANSI Z21.58-1998, standard for outdoor cooking gas appliances and CAN/CGA 1.6-M98, standard for outdoor cooking gas appliances.
7. Check your local building codes for proper method of installation. In the absence of local codes, this unit should be installed in accordance with National Fuel Gas Code No. Z223.1 Current Issue and National Electrical Code ANSI/NFPA No. 70 Current Issue or the CAN/CGA - B149.1 Natural Gas Installation Code or CAN/CGA - B149.2 Propane Gas Installation Code and C22.1 Canadian Electrical Code Part 1.
8. If you received a damaged product, immediately contact your dealer or builder. Do not install or use a damaged appliance.
9. **NEVER** cover any slots, holes or passages on the appliance, including the slots under the bottom of the control panel. Doing so blocks air flow through the grill and may cause carbon monoxide poisoning. Aluminum foil linings may also trap heat, causing a fire hazard. Keep all slots, holes and passages clear of grease and grime.
10. A **MINIMUM** clearance of 10 inches (254mm) must be maintained, above the countertop material, from all combustible vertical materials on the sides and behind the grill chassis and canopy.
11. On all models except OBSB162, a **MINIMUM** clearance of 1 1/4 inches (32mm) must be maintained, above the countertop material, from all non-combustible vertical materials on the sides and behind the grill chassis and canopy.
12. On model OBSB162, a **MINIMUM** clearance of 2 inches (51mm) must be maintained, above the countertop material, from all non-combustible vertical materials on the sides and behind the appliance.
13. A **MINIMUM** clearance of 1/4 inch (6mm) must be maintained, inside the base enclosure below the countertop material, from all vertical surfaces on the sides of the appliance, except on model OBSB162 (On OBSB162: 1/4 inch minimum at the back, 1/16 inch minimum clearance on the sides).
14. Do not locate this outdoor appliance under overhead unprotected combustible surfaces.
15. Keep the area around the appliance clear and free from combustible materials, gasoline and other flammable liquids.
16. This outdoor gas cooking appliance is not intended to be installed in or on a recreational vehicle or boat.
17. Do not leave the grill unattended while cooking.
18. Do not place any items in front of the unit while in use. This could obstruct the proper flow of air needed for combustion and ventilation.
19. Keep the ventilation openings of the enclosure free and clear of obstructions and debris.
20. Always inspect the natural gas or LP gas hose assembly before each use of the appliance. If you see evidence of abrasion, wear, or a cut gas connection hose then immediately replace the hose prior to operation of the appliance.
21. Keep any electrical supply cords and the fuel gas supply lines away from heating surfaces.
22. When the LP-gas cylinder is enclosed, it must be ventilated by openings on the sides, back and floor of the enclosure. Each opening must have a total area of no less than 10 square inches.
23. On models OB52 and OBS52, use only a two stage regulator on the gas supply line.
24. Do not install, repair or replace any part of the range unless specifically recommended in the literature accompanying it. A qualified service technician should perform all other service.
25. Before performing any type of service, make sure that the gas supply and electrical power to the appliance is turned off.

CALIFORNIA PROPOSITION 65 WARNING:

The burning of gas cooking fuel generates some by-products that are on the list of substances which are known by the State of California to cause cancer or reproductive harm. California law requires businesses to warn customers of potential exposure to such substances. To minimize exposure to these substances, always operate this unit according to the use and care manual, ensuring you provide good ventilation when cooking with gas.

Safety

IMPORTANT:

Your Dacor grill is designed to be safe when installed properly. However, care must be used as these grills can produce very high temperatures which increases the potential for injury or accidents. We recommend you always follow the safety notes listed below.

NOTES:

1. Carefully read this manual before using the grill, this will reduce the risk of injury due to fire or electric shock.
2. Proper installation is extremely important. Refer to the installation instructions included within the literature kit which shipped with your grill. Your installer should show you the location of the gas shut off valve and the electrical connection. You should also be familiar with the correct and easiest way to shut off these utilities in case of an emergency. Minimum clearances to combustible materials should always be observed. Reference the correct clearances in the installation instructions.
3. For proper outdoor grill operation (and drawer operation on units with a cart), use the outdoor grill only on a level surface.
4. Repair and replacement of any parts within this appliance should be referred to an authorized Dacor® service technician.
5. Children should never be allowed to sit, stand, or play around the grill at any time. Children should never be allowed to crawl inside the grill cart. Remember, when in use, the grill will get hot enough to cause severe burns.
6. Avoid the potential for grease fires by frequently cleaning the grease tray. Always allow the unit to completely cool down before removing the grease tray for cleaning.
7. Keep hands and fingers away from all edges of the canopy while in the raised position.
8. Never move the grill during cooking.
9. Always keep the canopy closed when moving the grill cart.
10. Spiders and insects can nest in the burners of this grill. This can obstruct the proper flow of gas into the burner and cause improper operation, fire hazard and potential damage to the unit. Periodically inspect the burners. If any of these symptoms occur, immediately refer to service or the troubleshooting section of this manual.
11. Your outdoor grill is equipped with a three-prong grounding plug to protect animals against shock hazard. This plug should be plugged directly into a properly grounded three-prong receptacle. Never cut or remove the grounding prong from this plug.
12. The grill canopy should be closed during the pre-heating period.

13. Gas Smells:

- If you smell gas when the unit is not in use, immediately shut off the gas at the main valve, open the canopy and call your local service agency to inspect the unit. Finding a leak is not a do-it-yourself process.
- If you smell gas when the unit is in use, immediately shut off the gas at the main valve, open the canopy, and dissipate for at least five minutes. Relight the burners and verify that they are operating properly. If the burners fail to light or are not functioning properly, shut off the main gas supply valve and call your local service agency for inspection.

14. Never block any of the vents located on the inside or outside of the appliance, including the ones under the control panel. Blocking any of these vents, will result in damage to the unit and may cause a fire or injury.

Liquid Propane Tanks

1. Dacor LP model grills are set at the factory for LP tank installations. Use only the Dacor supplied regulator. DO NOT ATTEMPT FIELD CONVERSIONS FROM LP TO NATURAL GAS OR FROM NATURAL GAS TO LP.
2. Dacor grills are approved for a maximum LP tank capacity of 20 pounds (5 gallons). The tank must be constructed and marked in accordance with the specifications for LP-gas tanks of the U.S. Department of Transportation (DOT) or the National Standard of Canada, CAN/CSA-B339, tank, Spheres and Tubes of the Transportation of Dangerous Goods. To minimize the potential for fire or an explosion, the following precautions should be observed when using, filling, or storing an LP tank:
 - Never use a dented or rusty LP tank. If there is any question as to the soundness of the tank, have it checked by your LP supplier.
 - Never use a tank with a damaged or defective shut off valve.
 - Do not over fill the LP tank. Never fill the tank beyond eighty percent (80%) of its capacity. Overfilling will cause the pressure relief valve on the tank to vent excess gas vapor. This vapor is combustible and can ignite, causing a fire.
 - When transporting an LP tank, ensure it is in an upright position and away from any sources of high heat.
 - Do not store additional LP tanks inside the cart of the unit. Tanks must be stored outdoors in a well-ventilated area out of the direct sunlight and/or sources of high heat, and out of the reach of children.
 - LP tank supply systems must be arranged for vapor withdrawal.
 - LP tank used must include a collar to protect the tank valve.

IMPORTANT:

1. For your safety, the gas supply must be turned off at the LP-gas supply tank when your grill is not in use.
2. The LP-gas supply cylinder must be disconnected when this barbecuing appliance is not in use.
3. If storing the unit indoors, you must detach the LP tank and leave it outdoors. This appliance is for outdoor use only.
4. Do not store disconnected LP tanks near this or any other appliance.
5. Check for leaks after every tank change.

Grill Features

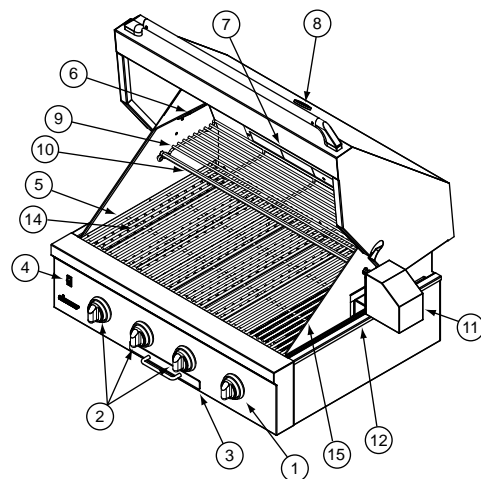

Features:

1. Rotisserie burner control knob
 2. Grill burner control knobs
 3. Drip tray
 4. Interior lights switch
 5. Porcelain grills (stainless steel optional)
 6. Halogen cooking lights
 7. Infrared rotisserie burner
 8. Canopy mounted temperature gauge
 9. Warm rack
 10. Rotisserie rod and forks
 11. Rotisserie motor
 12. Rotisserie motor bracket
 13. Removable smoker box (not shown)
 14. U shaped burners (under Heat control channels), three on OB36, two on OBS36
 15. Sear burner (OBS36 and OBS52 only)
- OB52 and OBS52 only:**
16. Side burner control knobs
 17. Side burners
 18. Side burner grate

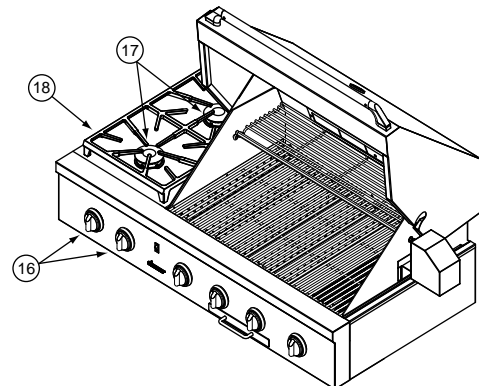

Outdoor Grill Freestanding Carts (optional):

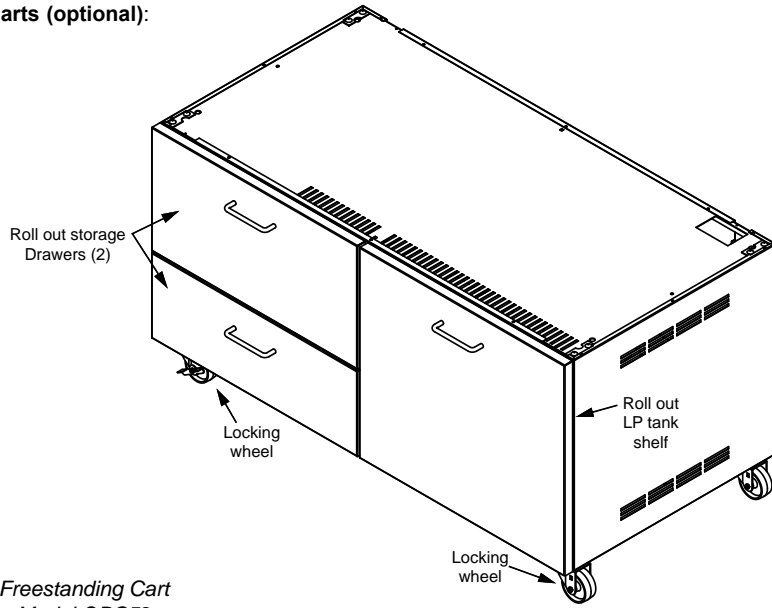

*Freestanding Cart
Model OBC52*

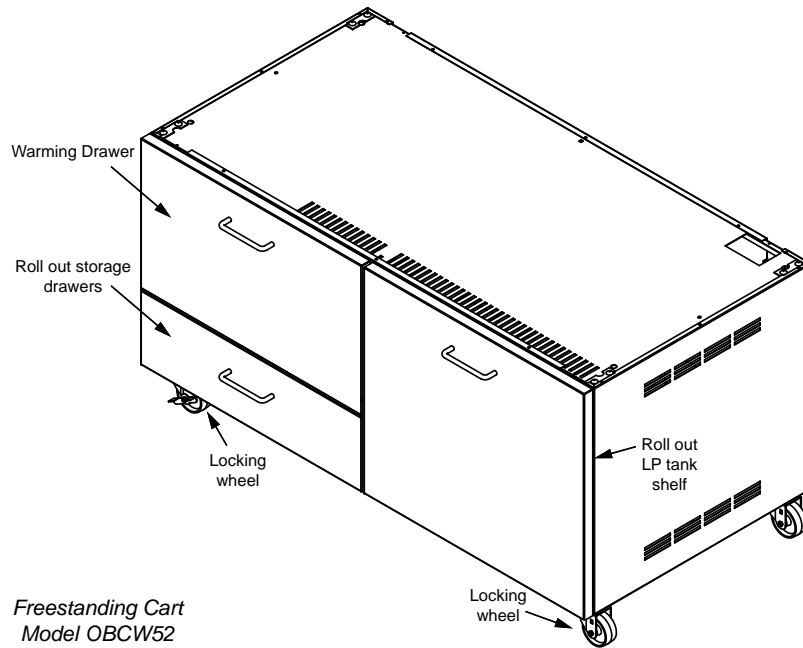

*Freestanding Cart
Model OBCW52*

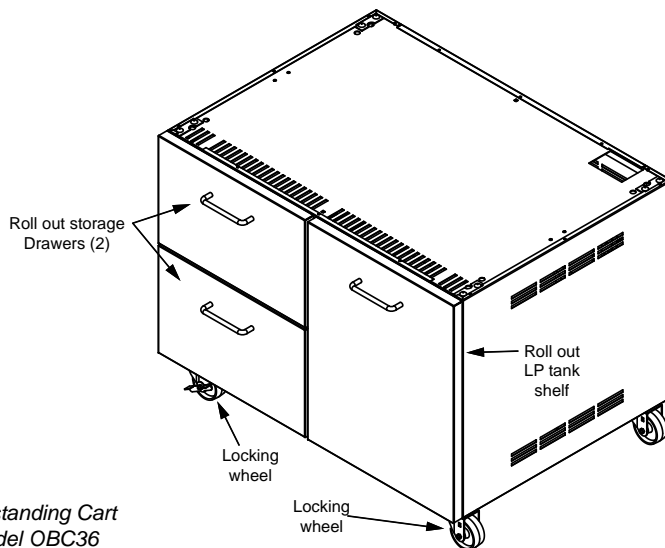

*Freestanding Cart
Model OBC36*

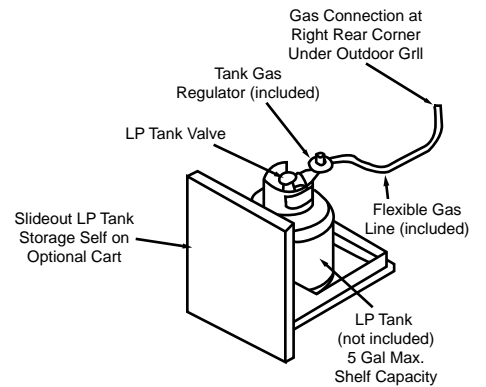

Installing the LP Tank in Cart

Lighting Liquid Propane Grills

WARNING:

Open canopy before attempting to light the appliance. Failure to open the canopy could allow gas to accumulate which could cause an explosion.

NOTES:

1. Reference your installation instructions for proper LP gas line connections to the Dacor® regulator and the “Main tank valve”.
2. Once the tank is properly installed:
 - Open the canopy to full open position.
 - Turn on the main tank valve.
 - Light one grill burner at a time by pressing in on the control knob and turning it counter clockwise until you hear the clicking ignition sound. Your burner should ignite within 4 to 10 seconds.
 - Repeat the last step with all control locations.

Lighting Natural Gas Grills

WARNING:

Open canopy before attempting to light the appliance. Failure to open the canopy could allow gas to accumulate which could cause an explosion.

NOTES:

1. Reference your installation instructions for proper natural gas line connections to the Dacor regulator.
2. Once you have confirmed that the electrical and gas are properly installed, begin the following processes:
 - Open the canopy to full open position.
 - Light one grill burner at a time by pressing in on the control knob and turning it counter clockwise until you hear the clicking ignition sound. Your burner should ignite within 4 to 10 seconds.
 - Repeat the last step with all control locations.
 - If ignition does not immediately take place, turn the burner valve handle off, wait 5 minutes, and repeat the lighting procedure.

Manual Lighting

WARNINGS:

FOR YOUR SAFETY FOLLOW THESE STEPS BEFORE ATTEMPTING A MANUAL LIGHTING PROCESS:

1. Turn all control knobs to OFF position.
2. Raise the canopy to its full open position.

NOTES:

1. Remove all of the grills to access the heat control channels.
2. Find the hole in the front of the heat control channel located directly behind the front control panel.
3. Use the match holder provided or a long stem match to light the grill burners manually.
4. Push in on the control knob and turn counter-clockwise while inserting the burning match into the access hole in the heat control channel. This should immediately result in ignition. If you do not experience immediate ignition, turn the control back to the off position.
5. After waiting for 2 to 3 minutes, begin the process with step 4.
6. If you cannot achieve ignition after two attempts, turn off all gas to the product and immediately call your authorized Dacor Customer Service Team for a service call.

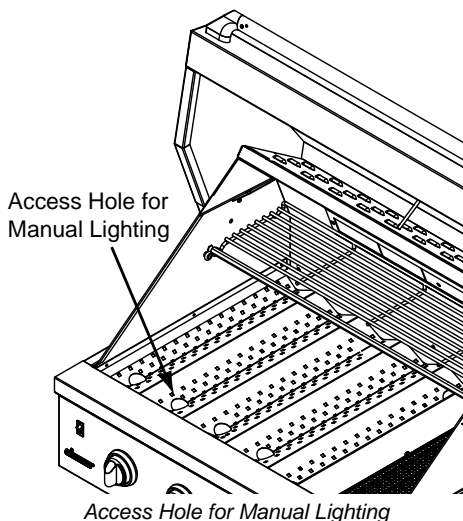

Canopy Mounted Temp. Gauge

NOTES:

1. Your Dacor® grill is equipped with a canopy mounted thermometer to assist you in various grill functions.
 - Preheating is an important part of proper grilling – preheat to approximately 225 degrees.
 - Smoking foods – heat to a temperature range from 225 to 300 degrees.
 - Grilling all types of foods – vary temperatures as needed from 225 to 500 degrees.
2. We recommend these temperatures as approximations.

Preheating Instructions

NOTE:

When preheating, set burners on high. Following preheat, adjust burners to desired temperature setting.

In order for the U- burners and burner box to remain clean, the gas burners and the flame spreaders have to be hot enough to vaporize fats/oils/marinades as they drip upon them. Without a proper preheat, these materials will collect on both the flame spreader and the burner tubes resulting in partial or total loss of ignition or a decrease in burner performance.

Always light every burner to generate maximum heat output and to assure even heat distribution. Using only one or two burners can eventually result in a buildup of unwanted material and could affect performance.

NOTE:

In colder climates the infrared burner may have to be used in order to achieve the preheat temperature.

Regardless of what you are barbecuing, use every burner. This assures even heat distribution and also improves grease/fat management. Using only one or two burners will eventually result in an unwanted buildup of material that might inhibit reliable performance.

After using the barbecue, allow it to continue heating an additional five minutes. This allows materials to move to the grease tray and away from the burner area. This assures clean burners and a healthy ignition system.

Grill Cooking

NOTES:

- Advanced preparation:
 - Bring all food items to be grilled to thawed temperature.
 - Check to make sure the drip retrieval tray is in position.
 - Preheat the grill with the canopy closed to a minimum of 225 degrees or the applicable cooking temperature for the food you are preparing.
- Begin the cooking process:
 - Once you have achieved the appropriate temperature for your chosen recipe, place the food product on the grill and begin the timing process.
- After completion of cooking:
 - Remove the food to serve and close the canopy for a safer environment.

Smoker Cooking

WARNINGS:

- Smoker cooking is done with the canopy in the down position. Smoke will be exhausting through the grill vents. Do not block vents. Blocking vents will damage the unit and may cause fire or injury.
- Smoker wood chips are soaked with liquids which create steam and smoke while barbecuing. Proceed with caution during cooking. This steam can be very hot and dangerous.
- Frequently, the smoker box will need to be refilled during cooking. It will be extremely hot. Exercise caution during this process. Steam and hot metal surfaces can cause personal injuries and possible fire.

NOTES:

- Smoker cooking enhances the flavors of food during grilling or rotisserie cooking.
- Your Dacor smoker box is a removable accessory that is shipped with your originally purchased grill product.
- The smoker should be filled with your choice of wood chips.
- Once you have prepared the wood and smoker box for use, while the grill is still cool, select a direct or indirect cooking location, then place the smoker box appropriately.
- To place the smoker box correctly
 - Determine desired smoker location.
 - Remove one small grill and the even heat channel. (The grills and even heat channels may be moved to create a smoker opening anywhere across the full width of the unit, except over the sear burner.)
 - Place smoker in the opening.

- Turn on the burner to maximum (HI) temperature. Leave the burner on high until the chips begin smoking. Then turn the heat down where the chips don't dry out or flame up.
- Recipes with long time duration will require the addition of wood and liquid to the smoker box. Remember, every additional time you open the grill canopy and smoker box, you will extend your recipe cooking times.

Rotisserie Cooking

WARNING:

This unit is equipped with a 3-prong grounding plug for your protection against shock hazard and should be plugged directly into a properly grounded receptacle. Do not cut or remove the grounding prong from this plug. Do not allow the rotisserie electrical cord to touch any heated surface of your grill.

CAUTION:

- Cooking with the rotisserie burner is not recommended during high wind.
- If any flame is blown out during windy conditions and does not automatically re-ignite within 5 to 7 seconds, turn off the control and attempt a new ignition until you hear the constant clicking stop and you see flame ignition.

NOTES:

- Rotisserie cooking utilizes the intense searing heat of the infrared burner and constant rotisserie rod rotation to cook many different types of meat.
- Rotisserie burner operation:
 - Rotisserie burner requires no pre-heating.
 - Rotisserie burner can be used in conjunction with grill burners and smoker box.
 - Push control knob and rotate 1/4 turn to the left (igniters will spark). If ignition does not immediately take place, within 4-10 seconds, turn burner knob off, wait 5 minutes and repeat lighting procedure.

- Rotisserie Motor and Rotisserie Rod
Prepare the grill for rotisserie cooking by following these steps:
 - Install the motor mounting bracket and motor by slipping the edge of the bracket down into the slot at the right side edge of the grill frame (as shown below).

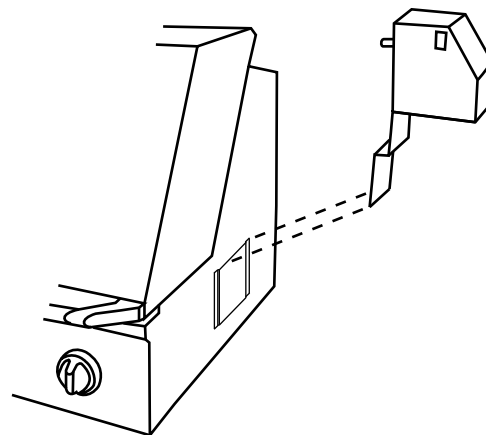

Rotisserie Installation

- Plug the motor power cord into 120 VAC grounded receptacle. Keep the cord away from all heated surfaces.
- Load your menu items on the rotisserie rod.
- Insert one side of the loaded rotisserie rod into the rod drive hole on the side rotisserie motor. Put the other side of the rod on the roller bearings on the left wall.
- Double check all rotisserie forks and locking screws for tightness to assure items will not move during rotation.
- Turn on the motor and observe several rotations to confirm the food is stable, then close the canopy completely and you are cooking.

Side Burners (Select Models Only)

IMPORTANT:

Do not place the burner cover over the burners while hot. Excessive heat contact with the cover may cause permanent discoloration.

NOTES:

- Largest recommended pot for these burners is 14 inches in diameter. Larger pots may contact the grill canopy during opening and closing.
- Automatic re-ignition systems will ignite an extinguished flame.
- Do not operate the side burner in windy conditions.
- The porcelain burner grate is durable, however continuous sliding of pots can remove surface material.
- A stainless steel side burner cover is made to cover the burner grate and burners when not in use.

Cleaning Tips

WARNING:

To avoid electric shock or burns, turn off all controls and ensure the grill is cool before cleaning. Do not store any type of cleaning products around the grill.

NOTES:

1. Read and follow the CARE AND CLEANING INSTRUCTIONS to ensure that proper grill operation and appearance will be maintained throughout the lifetime of the product. Several materials and finishes are used in the grill. Each material and finish must be properly cleaned according to the following recommendations. Failure to follow these recommendations may result in permanent damage to the grill.
2. To keep the grill looking it's best, clean it after every use.
3. Use the mildest cleaners or procedure available to perform the cleaning operation. Do not use commercial cleaners to clean any part of the grill.
4. Use only a sponge, soft cloth, fibrous or plastic brush and nylon pad for cleaning. Avoid the use of abrasive cleaners such as steel wool.
5. Always dry components completely before using the grill.
6. The use of brand names is intended only to indicate a type of cleaning agent or cleaning implement. All products listed by name must be used in accordance with the manufacturer's recommendations. Use of a brand name does not constitute an endorsement, nor does omission of a particular brand imply that a product is inferior.
7. After the smoker box and the wood remnants inside are cool, remove it for cleaning. Dump out the wood remnants and wash the smoker box with warm water and dish soap. Rinse the box well and dry it. Do not dump the remnants until they are cool.

Cleaning Exterior Surfaces

IMPORTANT:

1. Turn the knobs to the "OFF" position prior to removing them from the valve stems.
2. The grill should never be operated without the knobs in place.
3. Do not soak the knobs in water or place them in the dishwasher.
4. Do not expose the knobs to direct flame, hot utensils or other sources of heat.
5. Do not use abrasive or corrosive cleaners or applicators, as these could cause permanent damage.

NOTE:

Cleaning stainless steel varies with each part of the grill. To assist you, please refer to the list below for the suggested cleaning procedures:

1. Stainless Steel (canopy, chassis)
 - Wipe with the grain
 - Non-abrasive cleaners or
 - Mild abrasive cleaners
 - For stubborn areas, use the Dacor[®] Cooktop Cream supplied with the grill
 - Liberally apply the cleaner to a wet sponge. For best cleaning results thoroughly rinse off all residue.
2. Porcelain (grills, etc.)
 - Non-abrasive cleaners
 - Mild abrasive cleaners
3. Brass Burner Caps
 - Mild abrasive cleaners
 - Do not place burner caps in the dishwasher for cleaning.
4. Plastic (knobs)
 - Non-abrasive cleaners. (warm water with dish soap)

Cleaning Interior Surfaces

IMPORTANT:

To assist in the removal of the halogen light lens Dacor has included a pry stick. Gently slip the pry stick under the edge of the glass and pry away until the glass lifts. Remove the remaining distance by hand.

NOTES:

To assist you, please refer to the list below for the suggested cleaning procedures:

1. Stainless Steel (heat control channels, burner box, optional stainless grills)
 - Mild abrasive cleaners
 - De-greasers (such as 409)
 - Abrasive cleaners (limited applications)
 - Dacor Cooktop Creme and wet sponge
2. Stainless Steel (burners)
 - Mild abrasive cleaners
 - Abrasive cleaners (limited applications)
3. Glass (light lens)
 - Non-abrasive cleaners
 - Glass cleaners are acceptable
 - Warm soapy water
 - Dacor Cooktop Cleaning Creme

Before You Call for Service

Unnecessary service calls may be expensive, frustrating and time consuming. Before you call for service, please review the potential problems, possible causes and remedies shown in the table below.

Problem	Possible Cause	Remedy
1. Nothing works.*	Grill is not connected to electrical power.	Have grill connected to the proper electrical supply by a qualified electrician or appliance installer.
	Power supply is not energized.	Check circuit breaker, wiring, fuses, plugs, etc.
2. Igniters do not spark.*	Circuit breaker is tripped.	Reset circuit breaker.
	House fuse is blown.	Replace house fuse.
3. Sparking but no flame.	Gas shut-off valve is in "off" position.	Turn shut-off valve to "on" position.
	Ports on U-burner are clogged or dirty.	Brush U-burner with a steel brush and clear blockage with a toothpick or metal object (straightened paper clip, needle, or wire).
4. Burners ignite but flame is extremely large, distorted or yellow.	Ports on U-burner are clogged or dirty.	Brush U-burner with a steel brush and clear blockage with a toothpick or metal object (straightened paper clip, needle, or wire).
	Grill is being operated on wrong type of gas.	Ensure that the type of grill matches the gas supply (natural gas or LP, do not attempt to convert from one type to the other).
	Regulator is not installed, is faulty, or is set for the wrong type of gas.	Check installation, replace regulator, or set regulator for proper gas type.
5. Burner flame goes out at low setting.	Low gas pressure.	Contact gas company, have incoming gas pressure tested.
	Air intake holes under the control panel are obstructed.	Remove obstruction.
	Incorrect installation.	Check installation dimensions against installation instructions.
6. Igniters spark continuously after flame ignition.	Ports on U-burner are clogged or dirty at ignition location.	Brush U-burner with a steel brush and clear blockage with a toothpick or metal object (straightened paper clip, needle, or wire).
	Power supply polarity is reversed.	Have polarity corrected.
	Igniters are wet or dirty.	Dry igniters or clean igniters with a metal brush to remove any residue.
	Low burner flame.	Contact gas company, have incoming gas pressure tested.

* The grill burners can be manually ignited with a match or the hand spark ignitor supplied with the unit. (Refer to Manual Lighting section on page 4.)

Product Maintenance

No maintenance, other than the **CARE AND CLEANING INSTRUCTIONS** identified in this Use & Care Manual, should be attempted by the owner/operator. All other maintenance and service must be performed by a qualified appliance technician.

If You Need Service...

First, review the recommended checks listed in the **Before You Call for Service** section. Then, be certain that the appliance has been installed properly and is being operated correctly. Familiarize yourself with the warranty terms and conditions listed in the **PRODUCT WARRANTY** section on the inside back cover.

If the above checks have been completed and the problem has not yet been remedied, call your local authorized DACOR® service representative. Your dealer can normally provide the name and telephone number of the nearest service company.

DACOR works diligently to ensure your satisfaction when service is necessary. However, if you are not completely satisfied with the service provided, contact the company that performed the service and express why you are not pleased. Normally, they will be willing and able to resolve the problem.

If the service agency is not able to respond effectively, call or write the DACOR Customer Service Team. The phone number and address of this department are listed on the inside front cover of this manual. Please include your telephone number if you choose to write. We will then do our utmost to assure your happiness and satisfaction.

What is Covered

CERTIFICATE OF WARRANTIES
DACOR EPICURE™ GRILLS

WITHIN THE FIFTY STATES OF THE U.S.A., THE DISTRICT OF COLUMBIA AND CANADA*:
ONE-YEAR FULL WARRANTY

If your DACOR product fails to function within one year of the original date of purchase, due to a defect in material or workmanship, DACOR will remedy the defect without charge to you or subsequent users. The owner must provide proof of purchase, upon request, and have the appliance accessible for service.

FIVE YEAR LIMITED WARRANTY
Rotisserie burner

LIFETIME WARRANTY

All stainless steel components, including the burners, are warranted against rust through.

OUTSIDE THE FIFTY STATES OF THE U.S.A., THE DISTRICT OF COLUMBIA AND CANADA:

LIMITED FIRST YEAR WARRANTY

If your DACOR product fails to function within one year of the original date of purchase, due to a defect in material or workmanship, DACOR will furnish a new part, F.O.B. factory, to replace the defective part. All delivery, installation and labor costs are the responsibility of the purchaser. The owner must provide proof of purchase, upon request, and have the appliance accessible for service.

What is Not Covered

- Failure of the product caused by faulty installation, improper usage, or neglect of required maintenance.
- Service calls to educate the customer in the proper use and care of the product.
- Failure of the product when used for commercial, business, rental or any application other than for residential consumer use.
- Replacement of house fuses or fuse boxes, or resetting of circuit breakers.
- Damage to the product caused by accident, fire, flood or other acts of God.
- Breakage, discoloration or damage to glass, metal surfaces, plastic components, trim, paint, or other cosmetic finish, caused by improper usage or care, abuse, or neglect.

THE REMEDIES PROVIDED FOR IN THE ABOVE EXPRESS WARRANTIES ARE THE SOLE AND EXCLUSIVE REMEDIES. THEREFORE, NO OTHER EXPRESS WARRANTIES ARE MADE, AND OUTSIDE THE FIFTY STATES OF THE UNITED STATES, THE DISTRICT OF COLUMBIA AND CANADA, ALL IMPLIED WARRANTIES, INCLUDING BUT NOT LIMITED TO, ANY IMPLIED WARRANTY OF MERCHANTABILITY OR FITNESS FOR A PARTICULAR USE OR PURPOSE, ARE LIMITED IN DURATION TO ONE YEAR FROM THE DATE OF ORIGINAL PURCHASE. IN NO EVENT SHALL DACOR BE LIABLE FOR INCIDENTAL EXPENSE OR CONSEQUENTIAL DAMAGES. NO WARRANTIES, EXPRESS OR IMPLIED, ARE MADE TO ANY BUYER FOR RESALE.

Some states do not allow limitations on how long an implied warranty lasts, or do not allow the exclusion or limitation of inconsequential damages, so the above limitations or exclusions may not apply to you. This warranty gives you specific legal rights, and you may also have other rights that vary from state to state.

fold here

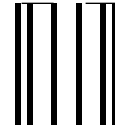

NO POSTAGE
NECESSARY
IF MAILED
IN THE
UNITED STATES

BUSINESS REPLY MAIL
FIRST-CLASS MAIL PERMIT NO. 4507 DIAMOND BAR CA

POSTAGE WILL BE PAID BY ADDRESSEE

DACOR INC.
ATTN: WARRANTY PROCESSING DEPT
1440 BRIDGE GATE DR STE 200
PO BOX 6532
DIAMOND BAR CA 91765-9861

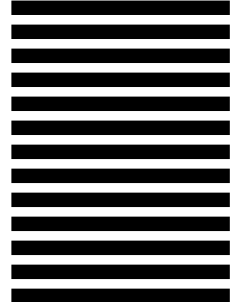

WARRANTY INFORMATION



IMPORTANT:

Your warranty will not be activated until you activate it online or return this form to Dacor. If you have purchased more than one Dacor product, please return all forms in one envelope or activate the warranty for each product online.

Please rest assured that under no conditions will Dacor sell your name or any of the information on this form for mailing list purposes. We are very grateful that you have chosen Dacor products for your home and do not consider the sale of such information to be a proper way of expressing our gratitude!

Owner's Name: _____
Last (Please Print or Type) First Middle

Street: _____

City: _____ State: _____ Zip: _____

Purchase Date: _____ Email: _____ Telephone: _____

Dealer: _____

City: _____ State: _____ Zip: _____

Your willingness to take a few seconds to fill in the section below will be sincerely appreciated. Thank you.

1. How were you **first** exposed to Dacor products? (Please check one only.)

- | | |
|---|---|
| <input type="checkbox"/> A. T.V. Cooking Show | <input type="checkbox"/> F. Builder |
| <input type="checkbox"/> B. Magazine | <input type="checkbox"/> G. Architect/Designer |
| <input type="checkbox"/> C. Appliance Dealer Showroom | <input type="checkbox"/> H. Another Dacor Owner |
| <input type="checkbox"/> D. Kitchen Dealer Showroom | <input type="checkbox"/> I. Model Home |
| <input type="checkbox"/> E. Home Show | <input type="checkbox"/> J. Other _____ |

2. Where did you buy your Dacor appliances?

- | | |
|--|---|
| <input type="checkbox"/> A. Appliance Dealer | <input type="checkbox"/> D. Builder |
| <input type="checkbox"/> B. Kitchen Dealer | <input type="checkbox"/> E. Other _____ |
| <input type="checkbox"/> C. Builder Supplier | |

3. For what purpose was the product purchased?

- | | |
|---|---|
| <input type="checkbox"/> A. Replacement only | <input type="checkbox"/> C. New Home |
| <input type="checkbox"/> B. Part of a Remodel | <input type="checkbox"/> D. Other _____ |

4. What is your household income?

- | | |
|---|---|
| <input type="checkbox"/> A. Under \$75,000 | <input type="checkbox"/> D. \$150,000 – \$200,000 |
| <input type="checkbox"/> B. \$75,000 – \$100,000 | <input type="checkbox"/> E. \$200,000 – \$250,000 |
| <input type="checkbox"/> C. \$100,000 – \$150,000 | <input type="checkbox"/> F. Over \$250,000 |

5. What other brands of appliances do you have in your kitchen?

- | | |
|------------------|-----------------------|
| A. Cooktop _____ | C. Dishwasher _____ |
| B. Oven _____ | D. Refrigerator _____ |

6. Would you buy or recommend another Dacor product?

- Yes No

Comments: _____

Thank you very much for your assistance. The information you have provided will be extremely valuable in helping us plan for the future and giving you the support you deserve.

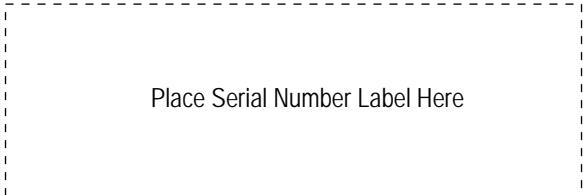

cut here

cut here