

Overview

The ZW-FMV is an advanced Plug & Play integration module designed for specific Ford vehicles, for flashing OEM lights in 'wig-wag' similar method with a simple press of a button. This unit comes pre-programmed with various light patterns and has on-board options for disabling specific lights.

Kit Content



ZW-FMV Module

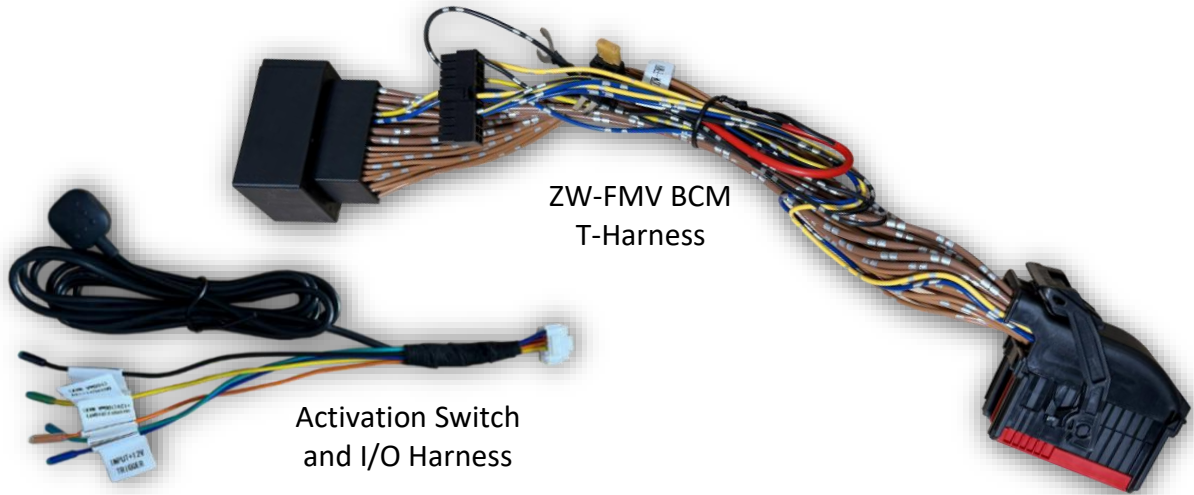

ZW-FMV BCM
T-Harness

Activation Switch
and I/O Harness

Module Connections

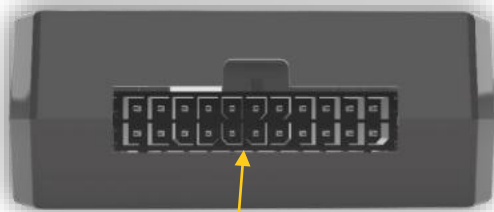

22-Pin (power/data connections)

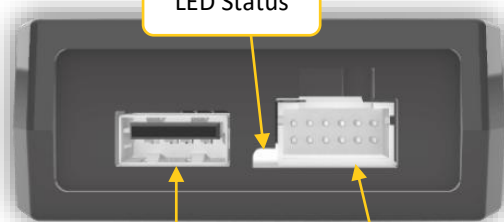

LED Status

USB (updates/software info)

12-PIN push button
I/O harness

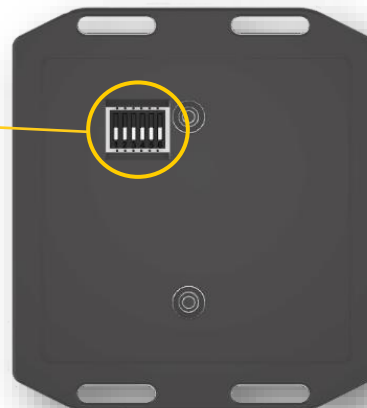

Dip Switch bank
(options)

ZW-FMV Operation:

1. Connect the Z-WAGZ unit to the factory Body Control Module (BCM). *Follow instructions on page 3 for more details and important information with this process.*
2. Turn Ignition ON or start vehicle (*Ignition must be ON or vehicle running for proper operation*)
3. **To activate Z-WAGZ:**
 - Press and HOLD the **high beam** lever (5 sec) OR
 - Press and HOLD the provided push button (3 sec) OR
 - Send a 12v (+) signal to the **blue wire** (designed to be extended for OE up-fitter switches or any aftermarket toggle). *For this input method, as long as the wire has 12v (+), the Z-WAGZ unit will stay active.*

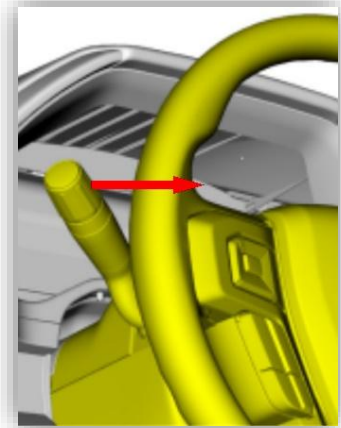

Pattern 1 will begin to flash. Once pattern 1 begins, the cluster turn signal (indicators) will blink 1 time, indicating Pattern 1 has been selected. The LED on the unit will blink **BLUE**. *See chart on page 5 for remaining pattern color indication.*

4. **To switch to Pattern 2:** (Pattern 1 must be currently active)
 - Engage either turn signal, then press and HOLD the **high beam** lever once more (5 sec). OR
 - Press & release the provided push button one time

The cluster turn signal (indicators) will blink twice indicating Pattern 2 has been selected. *Repeat this process to switch to the next pattern.*

5. **To deactivate Z-WAGZ:**
 - Press and HOLD the **high beam** lever (5 sec) OR
 - Press and HOLD the provided push button (3 sec) OR
 - Release 12v (+) signal to the **blue wire** (if connected this way) OR
 - Turn vehicle OFF

PLOW MODE will slow the currently selected pattern down, and fully disable High and Low beams from flashing. When **INPUT 2 (violet)** receives 12v (+) before activating the flasher, PLOW MODE is enabled.

General Z-WAGZ Notes

- Not all lights on the vehicle are necessarily used, some lights are not controllable via CAN data commands.
- Z-WAGZ will retain the last used pattern, even after being disconnected from the harness (if ever).
- Turn signals, headlights, reverse lights & brakes will override pattern flashing when used, until turned off again.
- Lights on the external mirrors will only flash if wired with turn signals from factory.
- 'Plow Mode', when active (INPUT 2), disables High & Low beam flashing and slows the pattern down so that the relay box (plow module) can keep up with the flashing (prevents overheating).
- If vehicle is equipped with physical actuators that activate for high beams/low beams, ZZ2 highly suggests disabling that beam from flashing (otherwise mechanical failure may occur quickly)
- Some vehicle models have a time limit for running (to save gas, etc), disable this on the radio by going to SETTINGS>VEHICLE>VEHCILE POWER DOWN TIMER

ZW-FMV Installation

1. Begin with vehicle OFF. **Leave vehicle OFF with front passenger door OPEN for 5 minutes minimum before beginning installation procedure. Failure to perform this step may trip CEL codes. Do not wake the CANbus during installation process (move seat, open doors, unlock anything, etc)**
2. From the provided T-Harnessing, locate the black **ground wire** with open ring terminal attached.
3. Remove the passenger side trim and kick panel quarter trim.
4. Removing the quarter panel will expose an **OEM grounding bolt**. Using a 10mm socket, loosen the nut and connect the ground wire first. After tightening, run the ground wire behind the OEM foam deadening over to the BCM area.
5. Next, remove the specific 10amp fuse shown below (5) and connect it to the provided fuse tap (attached to 22-PIN molex) in the empty slot (5a).
6. Connect the newly prepared fuse tap assembly to the fuse location shown below on the BCM (6).

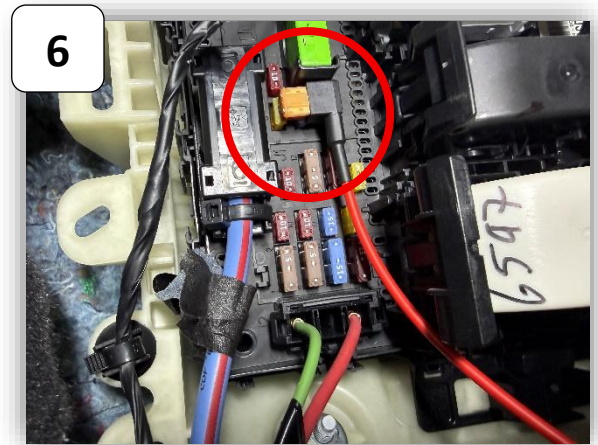
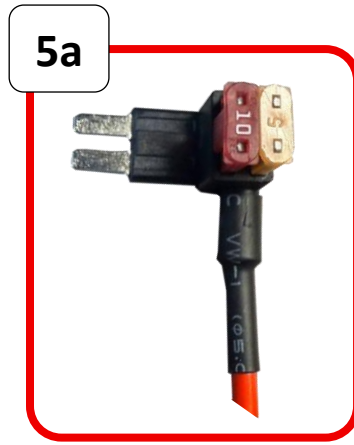
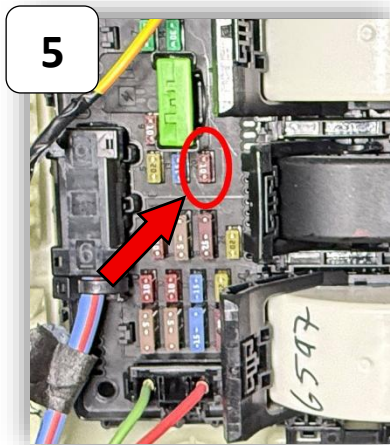

7. Remove the circled BCM plug (right) with a flat head (must be pried to release clip).
8. Connect the provided T-Harness plug to the BCM.
9. Connect the FMV module to the 22-PIN molex last.



Confirmed Vehicles

MAKE	MODEL	YEAR
Ford	Escape	2020-2025
	Bronco Sport	2021-2025
	Maverick	2022-2025
	Mach-E	2021-2025
	Transit Connect*	2019-2025

*Untested vehicle, but utilizes the same BCM.

ZW-FMV Installation Diagram

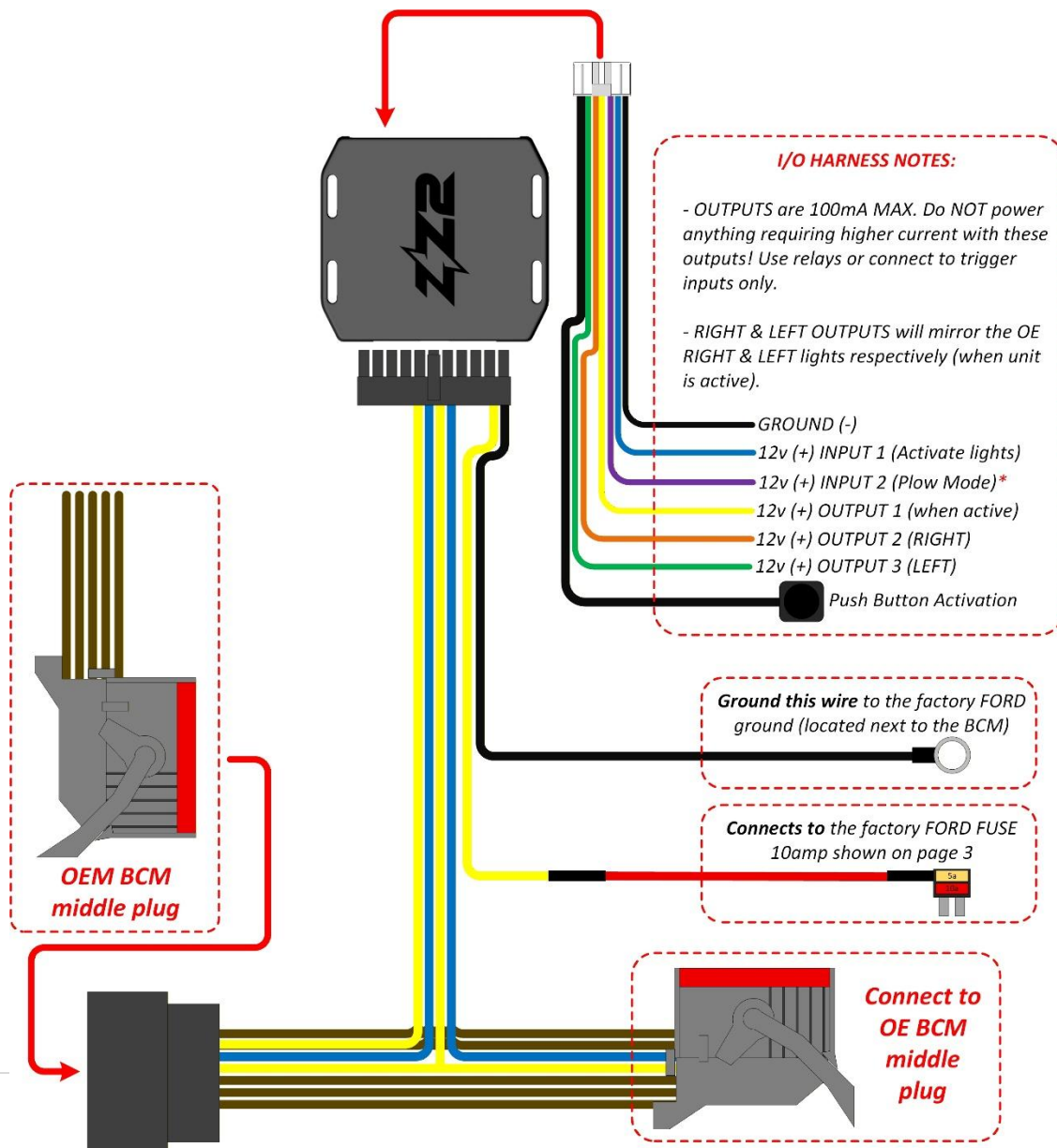

DIP Switch Settings (software: v1.0)

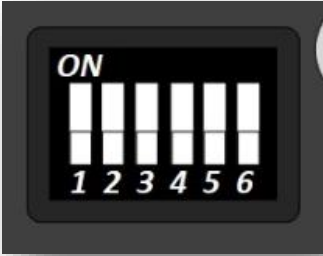

Located on the back side of the unit is a bank of (6) dip switches – you will need a pick-tool to adjust.

All dip switches are LIVE, do not unplug the module to adjust.



DIP	1	2	3	4	5	6
ON	Disable High Beam	Disable Low Beam	Enable Reverse Light <i>(may cause reverse camera to blink while active)</i>	Halogen (slower)	Disable STROBE Mode <i>(Removes strobe every 3 seconds)</i>	BRAKE + SIGNAL SEPARATE
OFF	Enable High Beam	Enable Low Beam	Disable Reverse Light	LED Lights (faster)	Enable STROBE Mode	BRAKE + SIGNAL TOGETHER

***DIP 6 ON:** For vehicles with separated Brake light and turn signal bulbs (separate housings, rear of vehicle)

***DIP 6 OFF:** For vehicles with Brake light and turn signal bulbs combined into the same housing (same housing, rear of vehicle)

SOFTWARE V1.0 NOTES:

- Rear DRLs will stay ON solid when Turn-Signal Priority is active
- Rear DRLs will stay ON solid during strobe mode
- If **turn signals or DRLs** never flash in patterns 1-7, try pattern 8
- If **high beams** never flash, turn ON DIP 2 or try pattern 6
- If **brake lights** never flash, try pattern 7
- 'Plow Mode', when active (INPUT 2), disables High & Low beam flashing and slows the pattern down so that the relay box (plow module) can keep up with the flashing (prevents overheating). This should be enabled whenever a plow is connected. *NOTE: this input must see 12v (+) before activating the Z-WAGZ for proper functionality.*
- When high beam is ON (high beam priority), low beam will be OFF and will not flash. This is a Ford limitation.
- When low beam is ON (low beam priority), high beam will be OFF and will flash. This is a Ford limitation.
- When high beam is flashing, low beam will typically not flash. Some Ford trucks will not be able to flash both high and low at the same time; you may choose one or the other by using DIP 1 or DIP 2 (see above chart).
- To flash DRLs, you must disable low beam (cannot flash low beam and DRLs at the same time). This is a Ford limitation.
- If low beam priority fails, disable high beam flashing (DIP switch 1 ON).
- When the vehicle is turned OFF, all flashing and unit will also deactivate.
- High Beam Lever act / External Button act / INPUT 1 +12V act requires Ignition ON to function properly. There is currently no way to activate the flasher unit when ignition is OFF.

ZW-FMV LED Status / Patterns [SW: v1.7]

START-UP INDICATION		
Description	LED Status	More Information
Initial Wake Up	Blinks BLUE (1 time)	Upon initial power connection
Unit recognizes CAN bus (car side ONLY)	Blinks BLUE (3 times)	Upon CAN data wake
Unit recognizes CAN bus (module side ONLY)	Blinks GREEN (3 times)	Upon CAN data wake
Unit recognizes CAN bus (properly)	Blinks BLUE, GREEN (x3)	Upon CAN data wake
Unit detects ACC info	Blinks GREEN (1 time)	Upon Turning Ignition ON
Unit detects GEAR info	Blinks VIOLET (1 time)	Upon switching transmission to Reverse gear
Unit detects HIGH BEAM pull OR External button press (for activation)	Solid GREEN	Upon pressing High Beam lever or provided push button
Unit receives negative response for light commands	Blinks VIOLET (x3)	--Contact ZZ2--
Unit not receiving confirmation for light commands	Blinks RED (x1)	--Contact ZZ2--
When unit goes to sleep	Blinks WHITE (x1)	When CAN shuts down
CAN bus communication problem	Blinks RED + GREEN	While Z-WAGZ is activated

PATTERN INDICATION		
Description	LED Status	More Information
Pattern 1	Blinks BLUE	BASE PATTERN
Pattern 2	Blinks GREEN	WATERFALL PATTERN
Pattern 3	Blinks RED	DOUBLE BLINK PATTERN (double back & forth)
Pattern 4	Blinks LIGHT BLUE	SINGLE BLINK PATTERN (single back & forth)
Pattern 5	Blinks VIOLET	SINGLE BLINK PATTERN (NO RED FLASH ON REAR)
Pattern 6	Blinks YELLOW	SINGLE BLINK PATTERN (TYPE 2) (HI INOP)
Pattern 7	Blinks BLUE/GREEN	SINGLE BLINK PATTERN (TYPE 3) (BRK INOP)
Pattern 8	Blinks BLUE/RED	ALT PATTERN, DRL/TRN SIG INOP (LIGHTNING PATTERN)
Pattern 9	Blinks GREEN/RED	ALT PATTERN 2, DRL/TRN SIG INOP (LIGHTNING PATTERN)

POWER CONSUMPTION / ADDITIONAL SPECS		
Description	Specification	More Information
Current Draw Active:	100mA max	
Current Draw idle:	7mA max	
INPUT 1 Trigger wire act:	12v (+)	Hardwire activation trigger
INPUT 2 Trigger wire act:	12v (+)	Hardwire activate PLOW mode
OUTPUT 1: 12v (+)	100mA max	Outputs 12v (+) whenever unit is active
OUTPUT 2 (RIGHT): 12v (+)	100mA max	Mimics RIGHT turn signal pattern
OUTPUT 3 (LEFT): 12v (+)	100mA max	Mimics LEFT turn signal pattern
Trigger wire idle:	3.3V	
Current limit:	10mA	

ZW-FMV Supported Lights*

FRONT LIGHTS		
<i>SUPPORTED LIGHTS</i>	<i>DIP PARAMETER</i>	<i>NOTES</i>
Low Beams	Dip Adjustable	Model-dependent, depends on high beam status
Front Turn Signals	N/A	If no flash, try pattern [8] or [9]
High Beams	Dip Adjustable	Model-dependent, depends on low beam status, if no flash, try pattern [6], model-dependent,
Fog Lights	N/A	--
Driver Running Lights (DRL)	N/A	Model-dependent, if no flash, try pattern [8] or [9], depends on low beam status for some models
Mirror Turn Signal Lights	N/A	--
Mirror Task Lights	N/A	Model-dependent, only patterns [8] & [9], only when parked
Cab Lights (beacons)	N/A	Model-dependent
REAR LIGHTS		
<i>SUPPORTED LIGHTS</i>	<i>DIP PARAMETER</i>	<i>NOTES</i>
3 rd Brake Light	N/A	Center High-Mounted
Brake Lights	N/A	Model-dependent, if no flash, try pattern [7]
Rear DRLs	N/A	--
Rear Turn Signals	N/A	If no flash, try pattern [8] or [9]
Reverse Lights	Dip Adjustable	--
Bed Lights (cargo)	N/A	Model-dependent, only when parked
License Plate Lights	N/A	--

*NOTE: As new variants of vehicles are released over time, some lights may not flash due to manufacturer design changes (software or the wiring to the housings themselves). The chart above is accurate for vehicles the ZW-FMV was tested on.