

BlueStar's premium all-gas Platinum Series range has been reimaged to include the groundbreaking X-8™ burners and a comprehensively redesigned oven to deliver the exceptional performance home cooks demand.

PRODUCT FEATURES

(*) To 350° in
30" oven

- Exclusive X-8™ star-shaped burner offers unmatched versatility and control on EVERY burner
- Go from extra-high sear - up to 25,000 BTUs - to an ultra-low warm of 500 BTUs on all burners
- Re-engineered oven preheats in 10-minutes*
- Improved convection system runs continuously for even heat distribution and consistent results
- Oversized oven fits commercial-size 18" x 26" baking sheet
- Commercial quality 1850° infrared broiler
- Refined design details elevate the range's premium aesthetic
- Unmatched customization - choose from 1,000+ colors and 7 metal trim finishes
- Handcrafted in Pennsylvania since 1880

SPECIFICATIONS

Range Dimensions: 59 7/8"W x 26 1/2"D x 36"H

Large Oven Interior: 26 1/4"W x 20"D x 16 5/8"H

Top Burner Rating: 25,000 BTUs

Simmer Burner Rating: 500 BTUs

Griddle Burner Rating: 20,000 BTUs

Oven Burner Rating: 30,000 BTUs

Infrared Broiler Rating: 15,000 BTUs

Electrical Requirements: 120V, 60Hz, 7 AMPs, 1 PH

(Unit must be on a Non-GFI, dedicated outlet)

Operating Gas Pressure: NAT: 5.0" WC, LP: 10.0" WC

Rec Gas Inlet Pressure: NAT: 6.0" WC, LP 11.0" WC

Gas Line Size: 3/4"

Oven Temperature Range: 150 F - 500 F

Oven Racks: 2 Glide & 1 Standard



MODEL CONFIGURATION

Six Burners
with 24" Griddle

BSPGR606G

BURNER CONFIGURATION

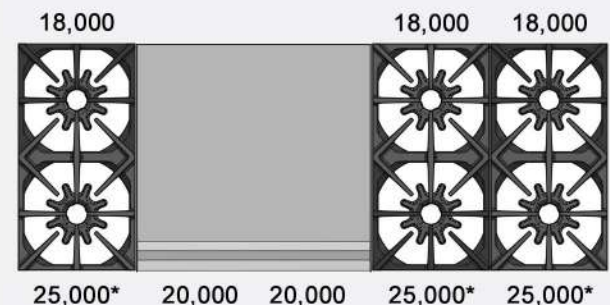

(*) 4% less output when configured for LP/Propane

ADDITIONAL CUSTOMIZATION OPTIONS

- 1,000+ Colors & Finishes
- Painted Knobs
- Multiple Designer Trim Options

*All specifications subject to change without notice.
Visit www.bluestarcooking.com for most up to date
information prior to installation or site preparation.*

FRONT VIEW

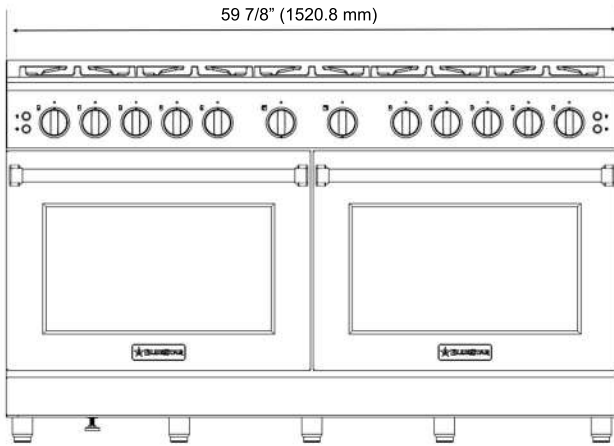

SIDE VIEW

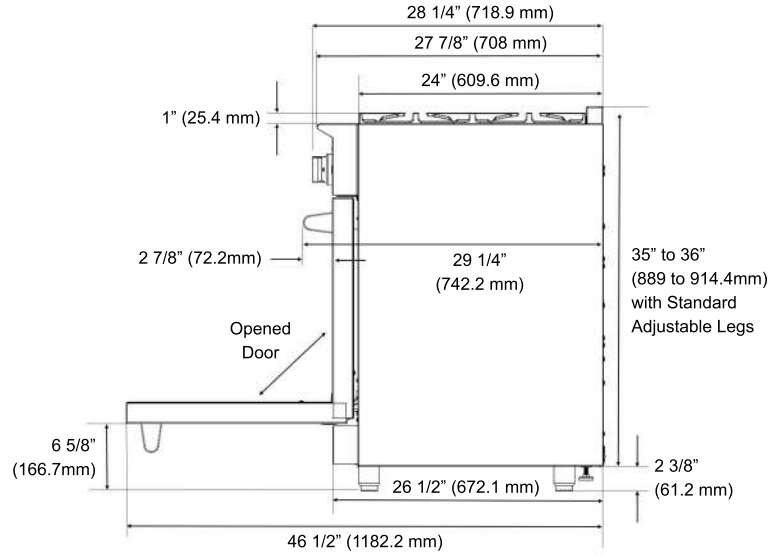

BACK VIEW

Site Preparation

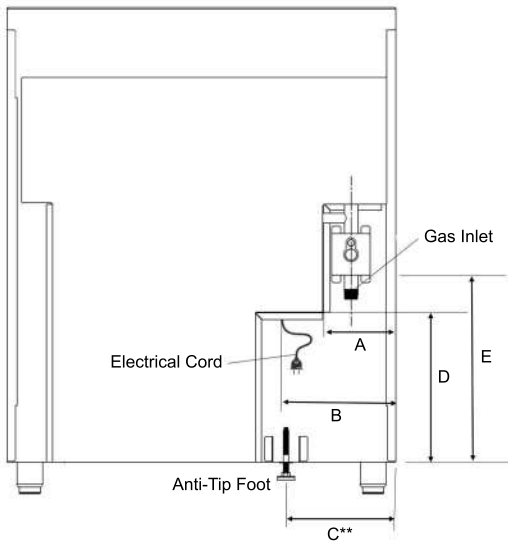

Model	A	B	C**	D	E
BSPGR30	5 1/16" (128.2 mm)	8 5/16" (211.9 mm)	8 7/16" (214.3 mm)		
BSPGR36	8 1/16" (204.4 mm)	11 5/16" (288.1 mm)	11 7/16" (289.8 mm)	11 9/16" (293.4 mm)	12 1/2" (318 mm)
BSPGR48	5 1/16" (128.2 mm)	8 5/16" (211.9 mm)	8 7/16" (214.3 mm)		
BSPGR60	5 1/16" (128.2 mm)	8 5/16" (211.9 mm)	8 7/16" (214.3 mm)		

FRONT VIEW

Cabinet Dimensions

Ventilation recommended for all installations at 30" - 36" (762 - 914.4 mm) above cooktop surface.

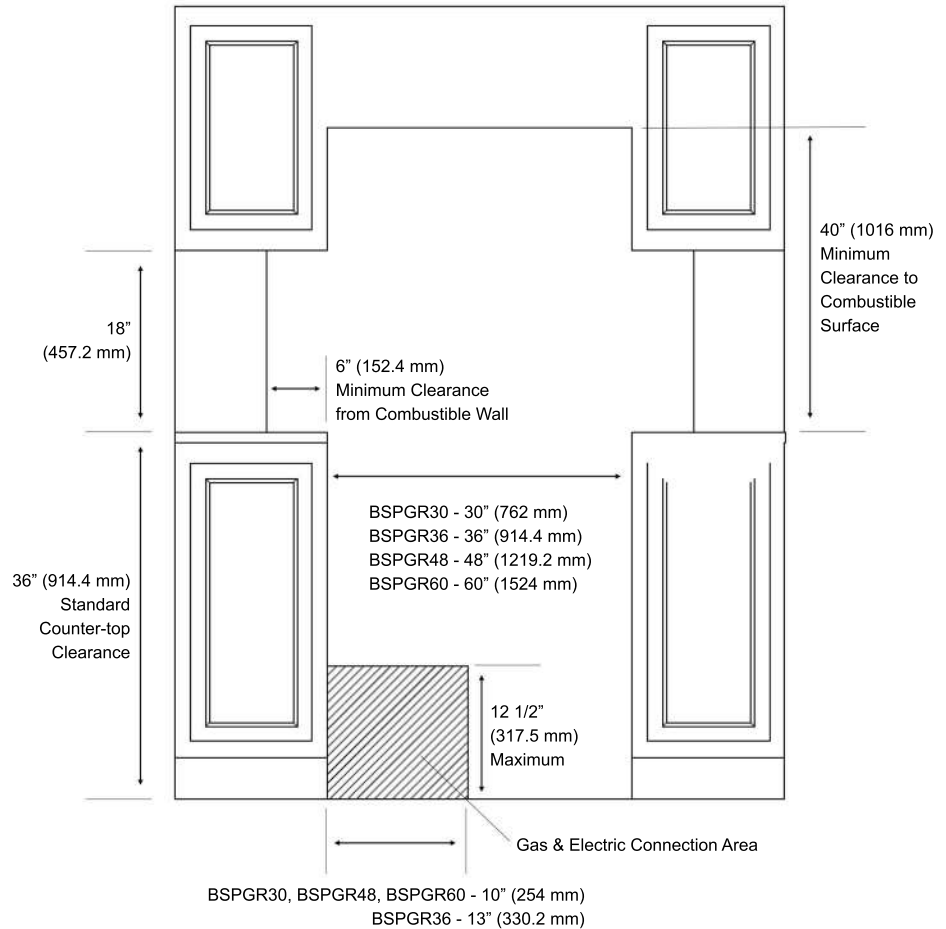

BSPGR30, BSPGR48, BSPGR60 - 10" (254 mm)
BSPGR36 - 13" (330.2 mm)