

HydroTap Elite Plus BCS Tap

Product Spec Sheet



HydroTap Elite Plus Boiling/Chilled/Sparkling (BCS) Tap

Offering the choice of instant filtered boiling, chilled and sparkling water, the minimalist and understated look and the streamlined design and clean lines of the HydroTap Elite Plus are sure to please.

This HydroTap Elite Plus can be installed over the sink as a secondary tap or over our optional Classic Plus Range Integrated or Classic Plus Range Raised Font / Drip Tray.

The HydroTap Elite Plus is available in six finishes: Chrome, Brushed Chrome, Matte Black, Brushed Gold, Brushed Nickel and Gunmetal.

HydroTap Elite Plus BCS Tap - Available Finishes



Chrome



Brushed
Chrome



Matte
Black



Brushed
Gold



Brushed
Nickel



Gunmetal

Product Order Codes for HydroTap Elite Plus BCS Taps

HydroTap Elite Plus BCS Tap in Chrome	01043222
HydroTap Elite Plus BCS Tap in Brushed Chrome	01043477
HydroTap Elite Plus BCS Tap in Matte Black	01043478
HydroTap Elite Plus BCS Tap in Brushed Gold	01043479
HydroTap Elite Plus BCS Tap in Brushed Nickel	01043481
HydroTap Elite Plus BCS Tap in Gunmetal	01043480

HydroTap Elite Plus BCS Tap

Product Spec Sheet



Installation Requirements

The HydroTap is a pump-driven system so the installation of the Tap must be within 3' (0.9m) of the base command center. Installation on most countertops is straightforward however, some stone countertops may require a specialized cutting service.

If using a drip tray (font) accessory, suitable drainage to a trapped waste is required within 3' (0.9m) of the installation. Sufficient space and clearance to install the HydroTap as detailed in the product installation guidelines is required.

Installation and connection of your HydroTap must be carried out by a qualified person, observing all local, state, & federal regulations.

HydroTap Elite Plus BCS - Tap Specs

Style:	HydroTap Elite Plus Tap (BCS) - includes boiling water safety lock
Hole Size:	1 - 3/8" / 35mm
Tap Height:	8 11/16" (221mm) or 14" (356mm) when installed with an optional font / drip tray
Installation:	Over sink as a secondary tap or on optional font / drip tray
Flow Rate:	Max 1.8gpm / 6.8lpm
Sparkling Water Flow Rate	0.4 gpm / 1.5lpm
Product Certifications:	IAPMO - NSF/ANSI 372, 42, 53, CSA B438.1, ASSE 1023, ASSE 1087; cUL; CEC
ADA Compliant:	Yes

Elite Plus - Tap View

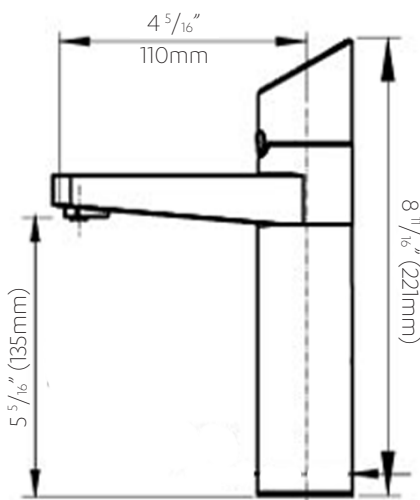

Elite Plus with Raised Font

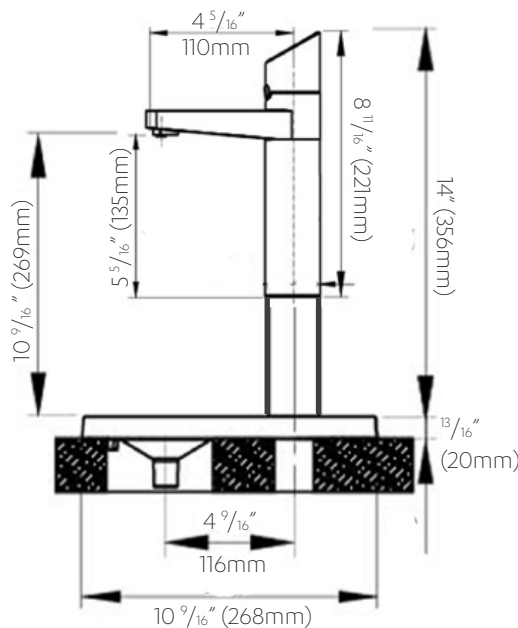

Elite Plus with Integrated Font

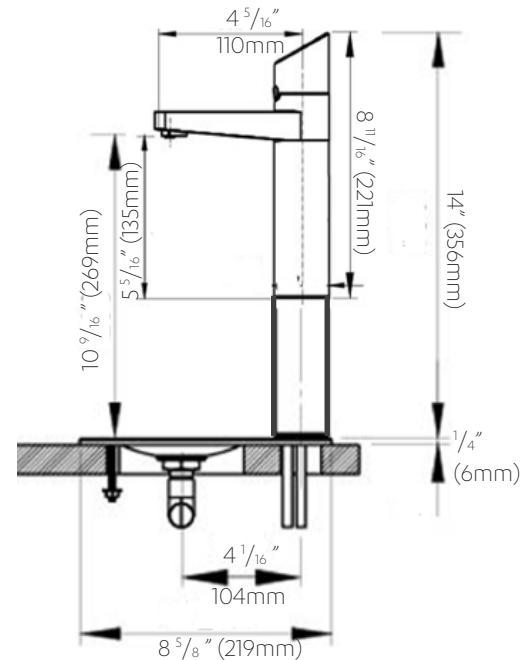

HydroTap 240V BCS G5 Kitted Command Center

Product Spec Sheet



HydroTap 240V BCS G5 Command Center Kitted with 5lb CO₂ and CO₂ Regulator

Product Order Code: 01048499

Elevate your drinking water at work by replacing your old, inefficient office water dispenser with a HydroTap BCS 240V system. Employees can enjoy on-demand boiling, chilled, and sparkling water at work.

This command center is kitted with our 5lb CO₂ and CO₂ regulator. It is ideal for commercial applications with up to 60 users and can be paired with any of our various tap styles.

HydroTap 240V BCS G5 Command Center - Product Specs

Product Order Code	01048499
Maximum number of users:	Up to 60 people
Water Pressure:	Min 37psi – Max 100psi (2.60 - 7.03kg/cm ²) with a minimum flow rate of 1 gpm (3.79lpm)
Water Connection:	½" BSP - isolation valve is required within 3' (0.9m) of the installation
Integral Water Values:	All HydroTap systems are fitted with a Dual Check Valve and a 50psi (3.52kg/cm ²) Pressure Limiting Valve
Water Supply Requirements:	Potable drinking water supply
Optimal Total Dissolved Solids (TDS) Range:	TDS Min 50ppm – Max 150ppm
Integral Water Filter:	0.2 micron, 1.5 size - replace every 1,800 gallons / 6,813 liters (~6 months for a large office)
Power Rating:	220-240V, 50-60Hz, 15 amp power supply with a NEMA 6-15 outlet
Dimensions (WxDxH):	15.5" x 18.2" x 13.1" / 395mm x 464mm x 333mm
Minimum Air Gap:	Minimum of 2" / 50mm clearance on left and right side and 8" / 200mm above
Minimum Cabinet Size:	24" wide x 24" deep / 610mm wide x 610mm deep
Maximum Hose Connection Length	3' / 0.9m (tap to command center)
Dry Weight:	90.4lbs / 42kg
Product Approvals:	IAPMO - NSF/ANSI 372, 42, 53, CSA B483.1, ASSE 1023, ASSE 1087; cUL; CEC
Warranty:	2-year limited parts and labor warranty
Included CO₂ Cylinder:	5lb CO ₂ with CGA-320 fitting and CO ₂ Regulator
CO₂ Operating Pressure:	Min 39psi - Max 44psi / Min 2.74 - Max 3.09kg/cm ²

HydroTap 240V BCS G5 Command Center

Product Spec Sheet



Installation Requirements

Installation and connection of your HydroTap must be carried out by a qualified person, observing all local, state, & federal regulations. You will require suitable 220 -240V 50-60Hz, 15 amp power supply with a NEMA 6-15 electrical outlet within 5' 9" (1.75m) of the product.

The HydroTap is a pump-driven system so the installation of the Tap must be within 3' (0.9m) of the base command center. The HydroTap is an air-cooled system so discrete cabinetry cut-outs are required for ventilation. Installation on most countertops is straightforward however, some stone countertops may require a specialized cutting service.

If using a drip tray (font) accessory, suitable drainage to a trapped waste is required within 3' (0.9m) of the installation. If you live in an area with hard water (more than 150ppm), we recommend installation of a scale filtration kit or water softener. Sufficient space and clearance to install the HydroTap as detailed in the product installation guidelines is required.

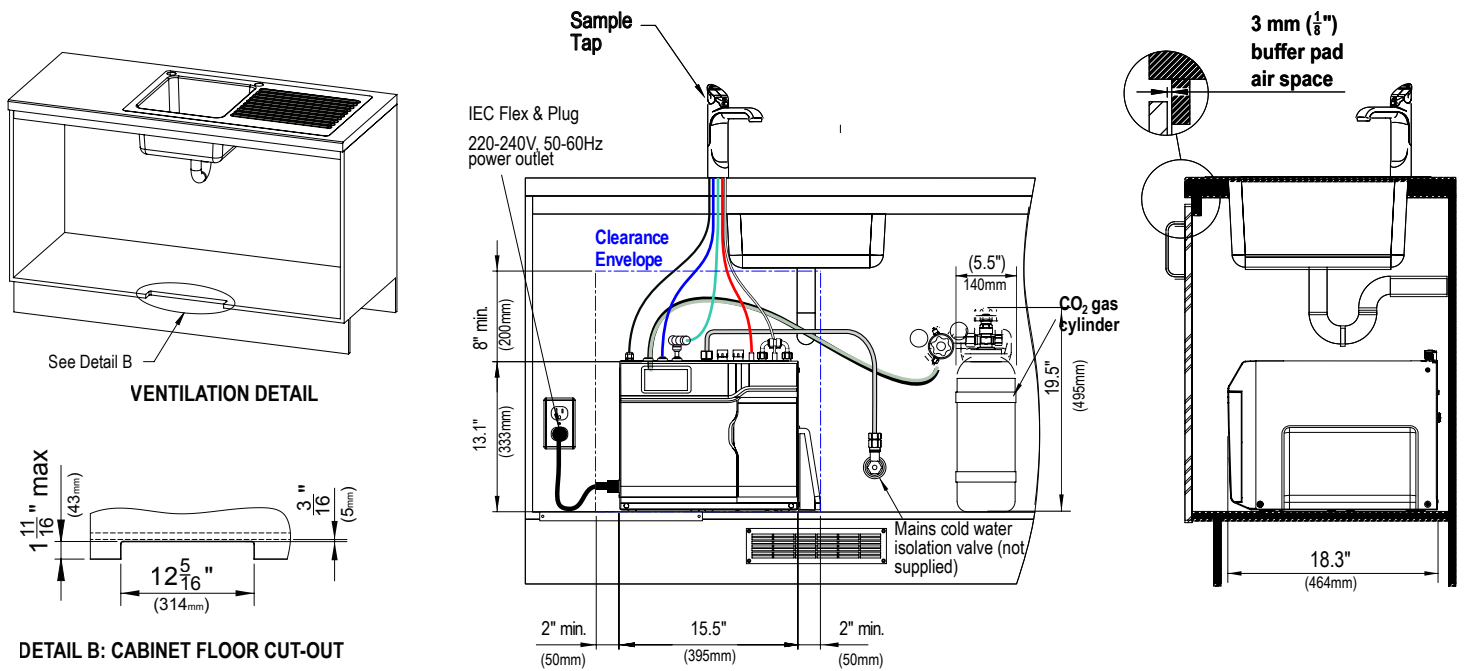

Scan QR code to view installation guide.

Installation by Zip Professional Service is available in select metro areas and can be arranged with a phone call to 1-833-233-2358 or by emailing wecare@na.zipwater.com. Technical Installation assistance over phone or video call can be obtained by calling our customer care line at 833-233-2358, Monday through Friday 8am - 5pm Central Time.

5lb CO₂ Cylinder + Regulator

Detailed Spec Sheet



5lb CO₂ Cylinder and CO₂ Regulator - Product Specs

Product Description:	1 x 5lb Beverage-Grade Carbon Dioxide Cylinder with Regulator
CO₂ Capacity:	Approximately 1200 8oz cups (per cylinder)
CO₂ Operating Pressure:	Min 39psi - Max 43psi / Min 2.74 - Max 3.02kg/cm ²
CO₂ Height (without regulator):	Approximately 18" / 457mm
CO₂ Diameter:	Approximately 5.5" / 140mm
CO₂ Regulator Height:	Approximately 6" / 152mm
CO₂ Regulator Width:	Approximately 7" / 178mm
CO₂ Regulator Depth:	Approximately 4.3" / 109mm
Valve Type:	CGA-320
Max Height (with regulator)	Approximately 19.5" / 495mm
Max Width (with regulator):	Approximately 10.5" / 267mm
Storage Temperature:	CO ₂ should be stored out of direct sunlight. Max storage temperature is 120°F (48.8°C)

