

PRESTIGE®

Assembly Guide
Guide d'assemblage
Guía de ensamblaje

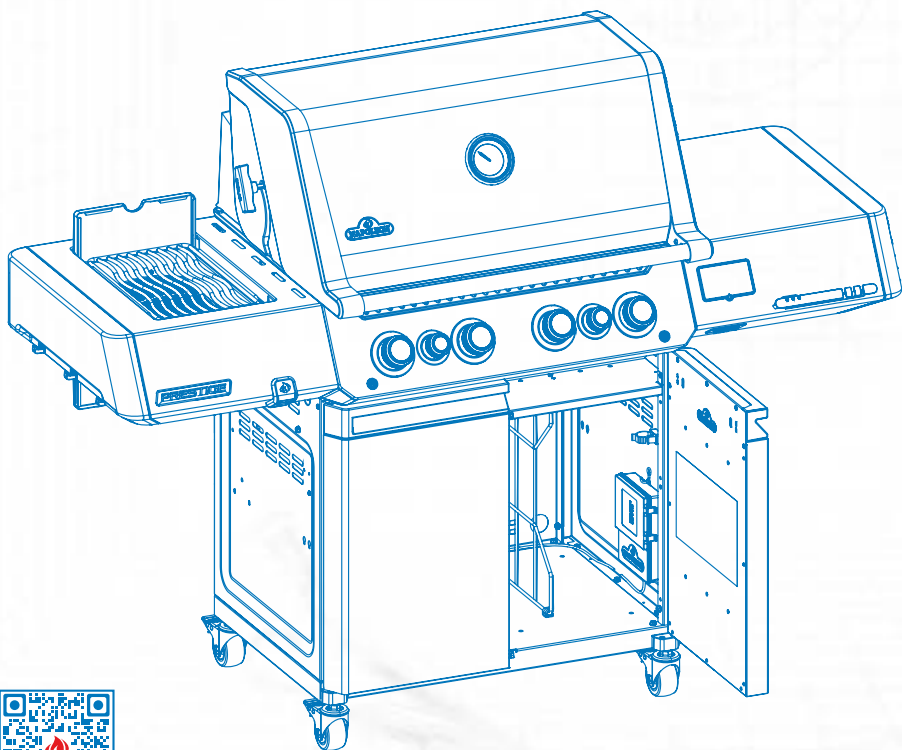

Scan to upgrade your experience.
Scannez pour améliorer votre expérience.
Escanee para mejorar tu experiencia.

Ⓔ Models Ⓕ Modèles Ⓔ Modelos

P500VX

Natural Gas & Propane | Gaz naturel et propane | Gas natural y propano



Assembly Guidelines | Guide de montage | Guía de instalación

Safety requirements
Exigences de sécurité
Requerimientos de seguridad



Tools requirements for installation (not included)
Outils nécessaires à l'installation (non inclus)
Herramientas necesarias para la instalación (no incluidas)



3/8
(10 mm)



3/8
(10 mm)

Tool included
Outil inclus
Herramienta incluida



Wi-Fi / Bluetooth®
compatible
Compatibles
Wi-Fi / Bluetooth®
Compatible con Wi-Fi / Bluetooth®



Legend | Légende | Leyenda



Warning!
Avertissement !
¡Advertencia!



Caution!
Attention !
¡Precaución!



Cut here
Coupez ici
Corte aquí



Repeat step.
Répétez l'étape.
Repite el paso



Critical position
Position critique
Posición crítica



Lock
Sécurisé
Asegurar



Propane only
Propane uniquement
Sólo propano



Look closely!
Regarder attentivement!
¡Mira de cerca!



Remove protective film.
Retirer le film protecteur.
Retire la película protectora.



Handle with care.
Manipuler avec précaution.
Manipular con cuidado.



Natural Gas
Gaz naturel
Gas natural



Magnetic attachment
Fixation magnétique
Accesorio magnético

WELCOME TO NAPOLEON®!

Congratulations on upgrading your grilling game and welcome to the **NAPOLEON®** family!



Ready to assemble your new grill?



There may be visual differences between illustrations and model purchased. Remove all parts from packaging before assembling the barbecue. Set up this assembly on a solid, level and horizontal surface.



Use the main carton as a surface to assemble the unit to prevent scratches and damage during the assembly process.



Register your grill today.

We're here to accompany you through unforgettable moments.

BIENVENUE À NAPOLEON®!

Félicitations pour votre achat et bienvenue dans la famille **NAPOLEON®**!



Prêt à assembler votre nouveau grill?



Veillez noter qu'il peut y avoir des différences entre les illustrations de ce guide et le modèle acheté. Retirez toutes les pièces de leur emballage avant de commencer. Veillez à assembler votre grill sur une surface plane et solide.



Utilisez le carton principal comme surface pour assembler l'appareil afin d'éviter les rayures et les dommages pendant le processus d'assemblage.



Inscrivez votre grill dès aujourd'hui.

Nous sommes là pour vous accompagner dans des moments inoubliables.

¡BIENVENIDO A NAPOLEON®!

¡Felicidades por mejorar tu juego de parrilla y bienvenido a la familia **NAPOLEON®**!



¿Listo para ensamblar tu nueva parrilla?



Considere que puede haber diferencias entre las ilustraciones en esta guía y el modelo adquirido. Remueva todas las piezas de sus empaques antes de comenzar. Asegúrese de ensamblar la parrilla en una superficie plana y sólida.



Utilice la caja de cartón principal como superficie para montar la unidad a fin de evitar arañazos y daños durante el proceso de montaje.



Registra hoy mismo tu parrilla.

Estamos aquí para acompañarte en momentos inolvidables.

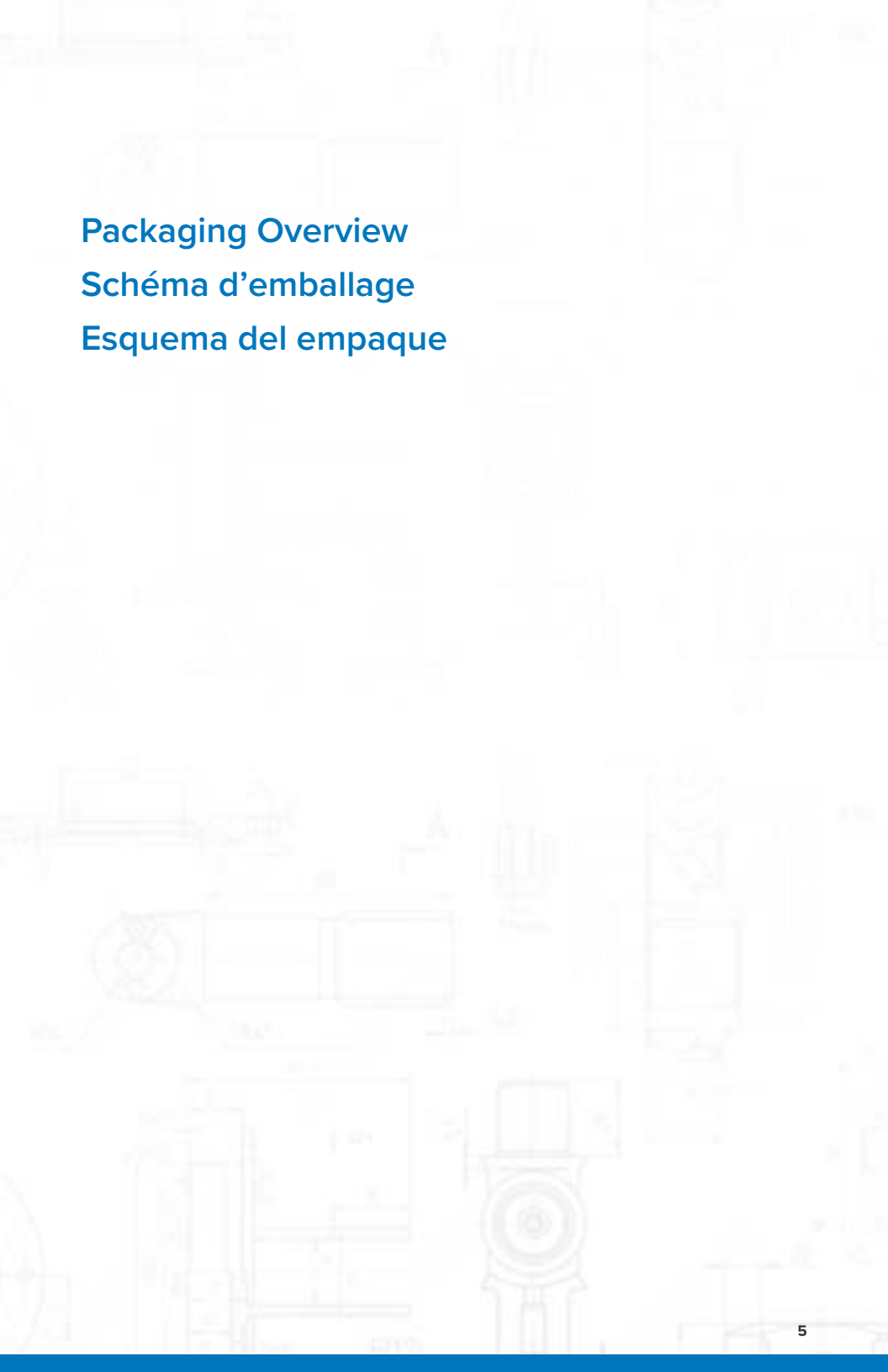

Packaging Overview
Schéma d’emballage
Esquema del empaque

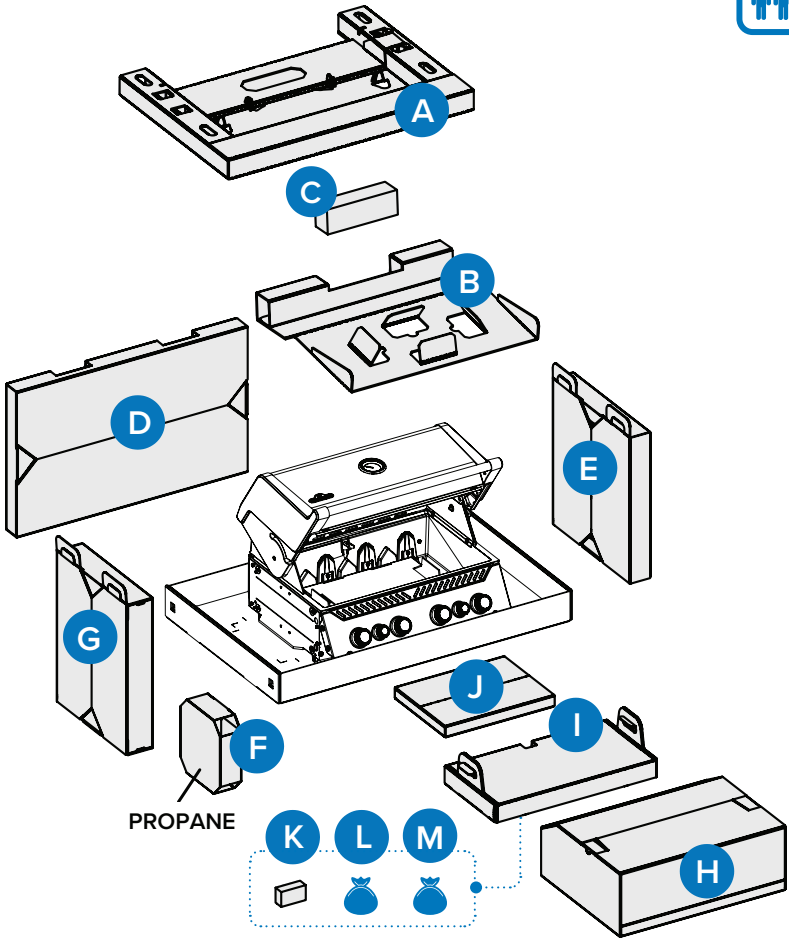

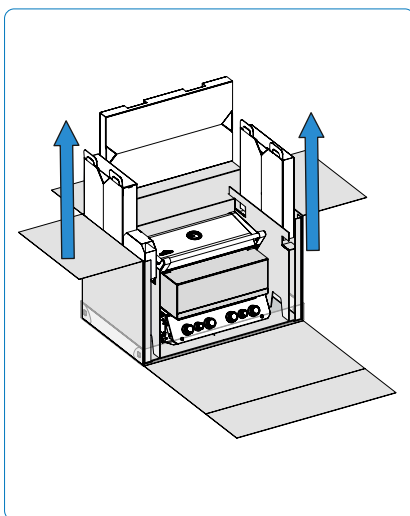
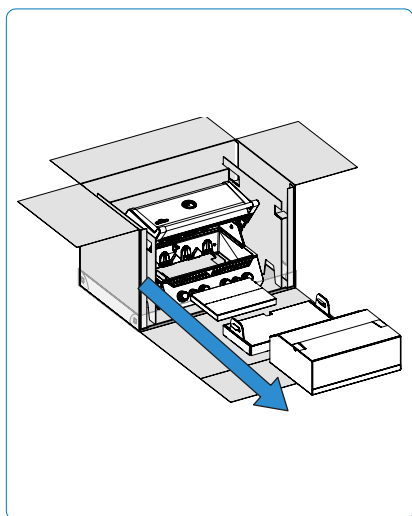
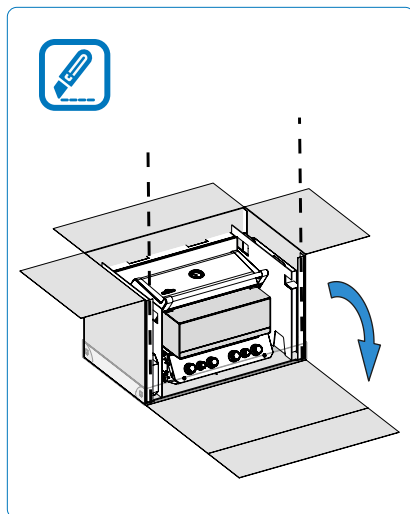
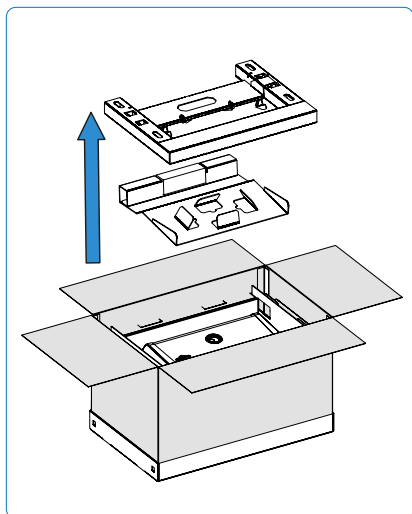

P500VX

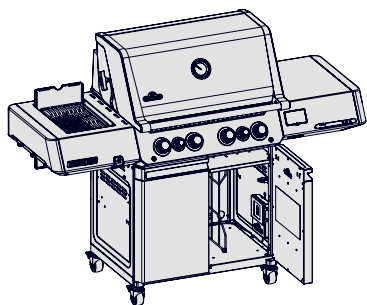

Kit Contents | Contenu du kit | Contenido del kit

A



x1

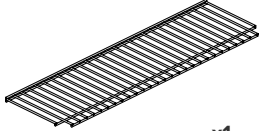

x1

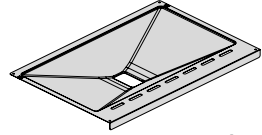

x1

B

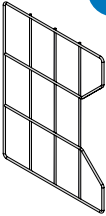

x1

C

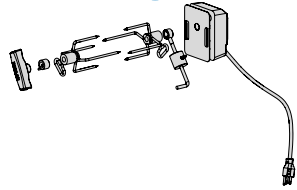

D

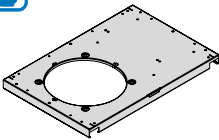

x1

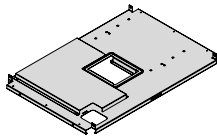

x1

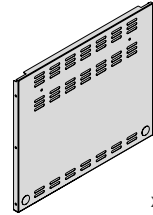

x1

E

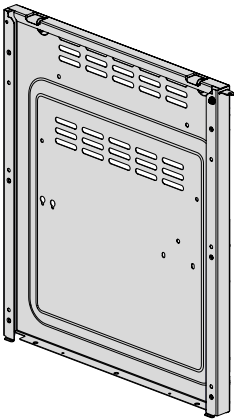

x1

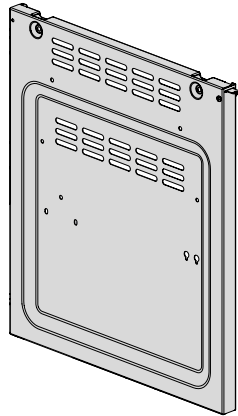

x1

Kit Contents | Contenu du kit | Contenido del kit

F

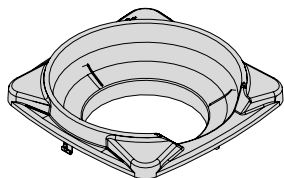

x1

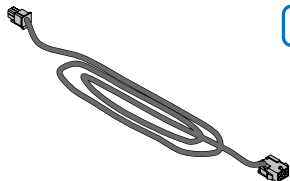

x1

G

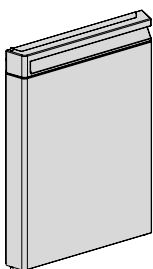

x1

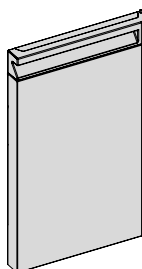

x1

H

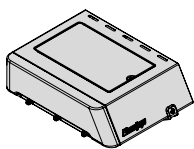

x1

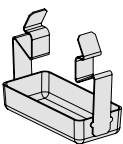

x1

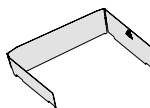

x1

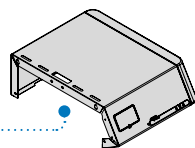

x1

J

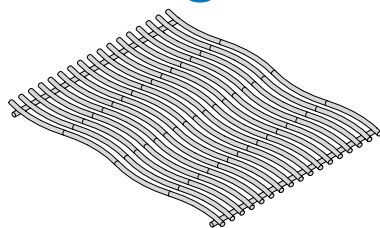

x2

Kit Contents | Contenu du kit | Contenido del kit

I

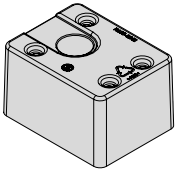

x2

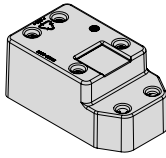

x2

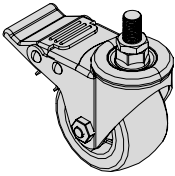

x4

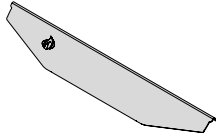

x7

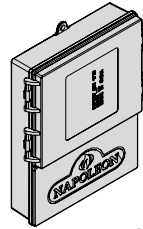

x1

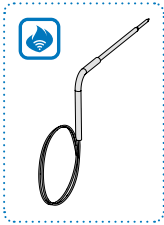

x3



x3

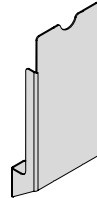

x1

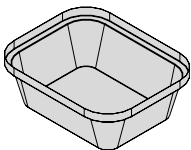

x1

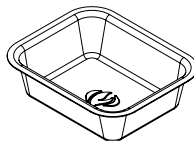

x1

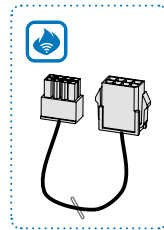

x1

Kit Contents | Contenu du kit | Contenido del kit

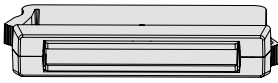

x2

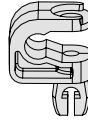

x4



x2

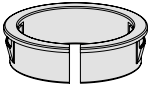

x1

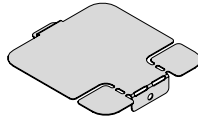

x1

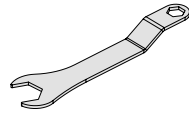

x1

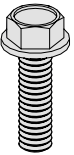

x10



x10



x30



x1

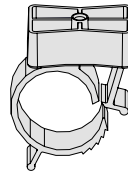

x1

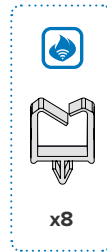

x8

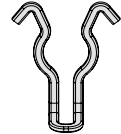

x1

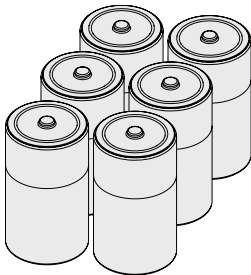

2 Boxes



Assembly Steps
Étapes de l'installation
Pasos para la instalación

1

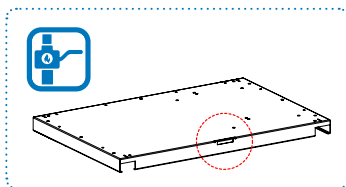
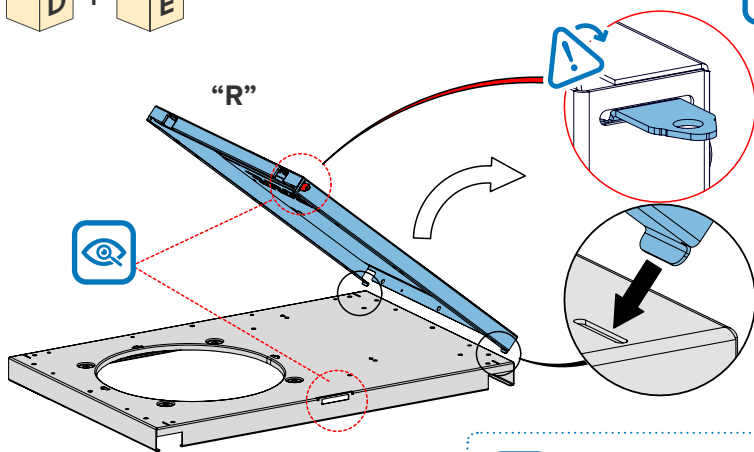

2

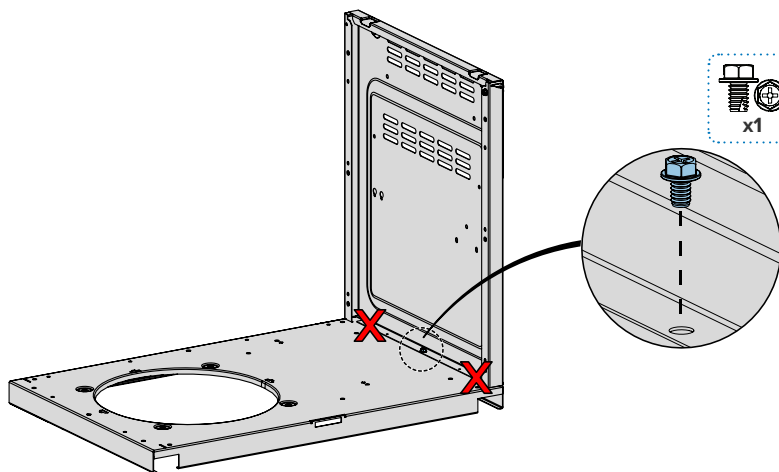

3

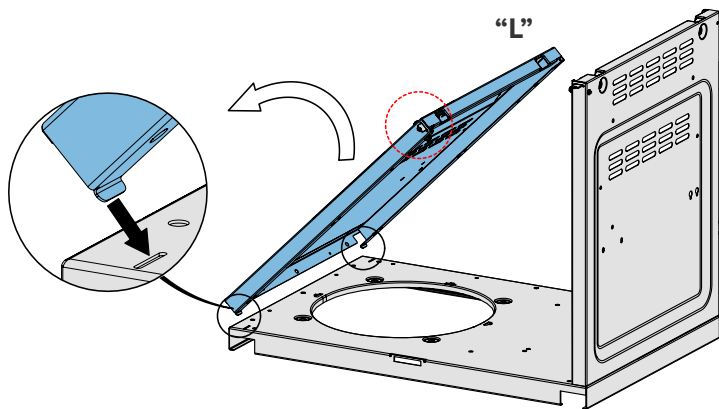

4

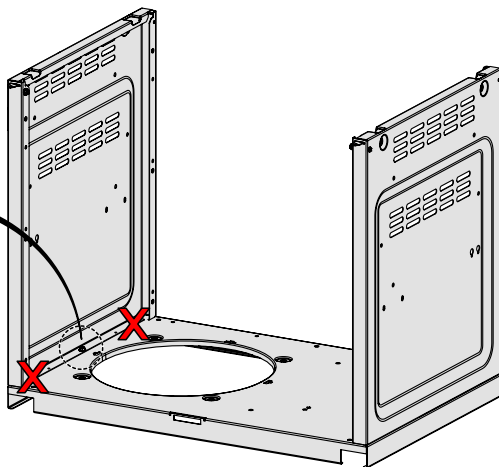
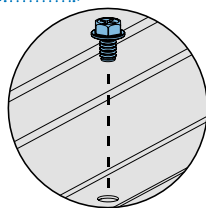

5

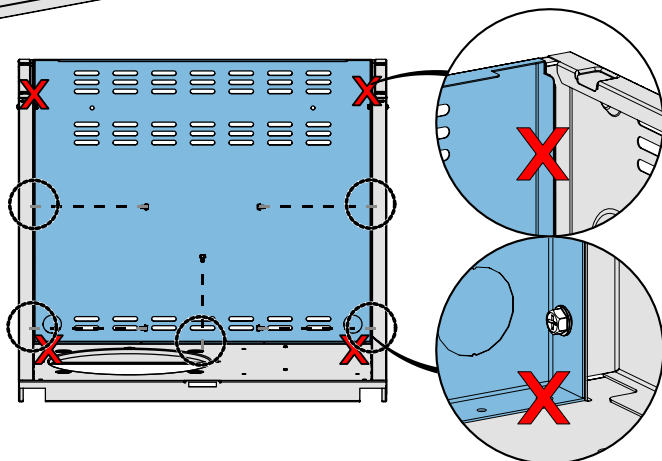
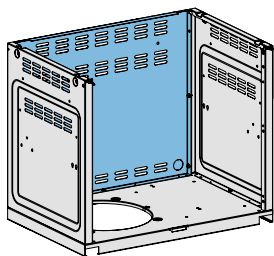

6

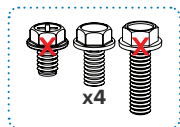
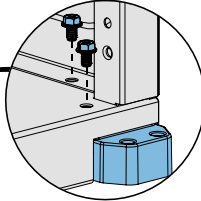
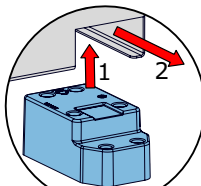
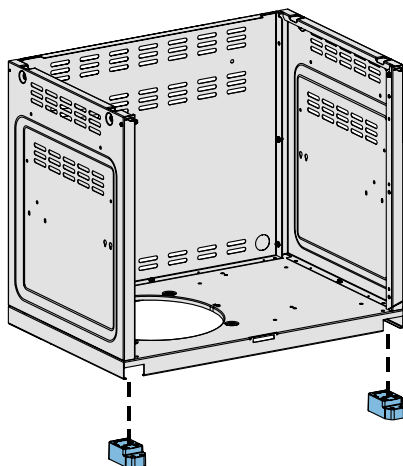

7

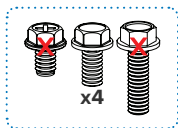
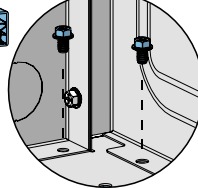
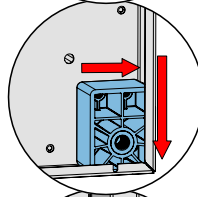
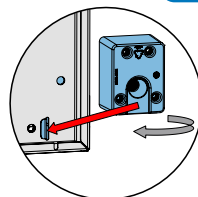
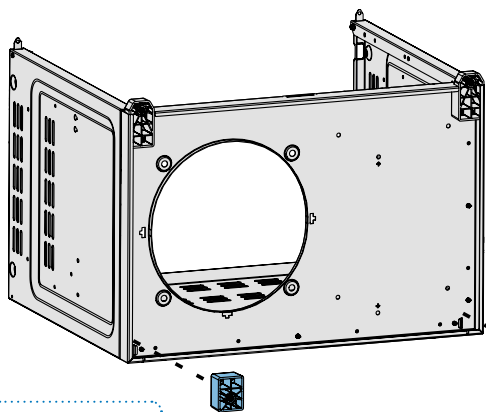

8

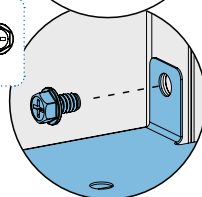
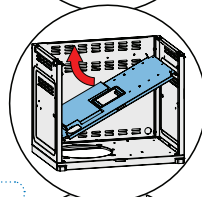
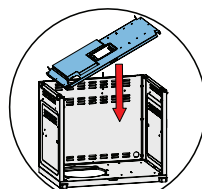
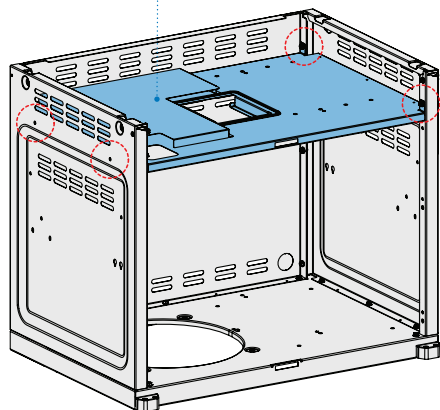
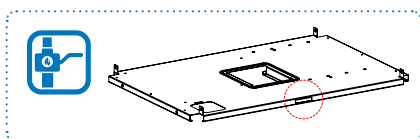

9

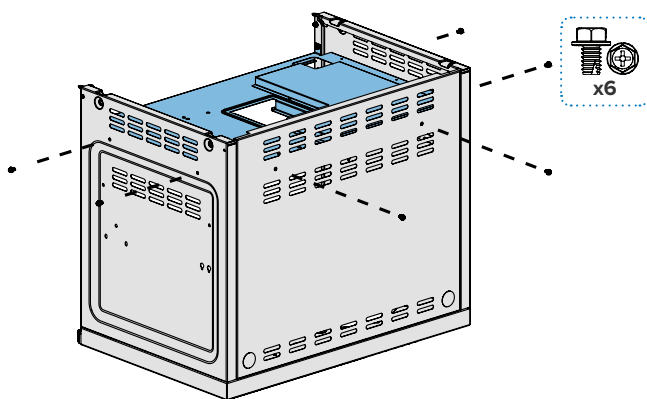

10

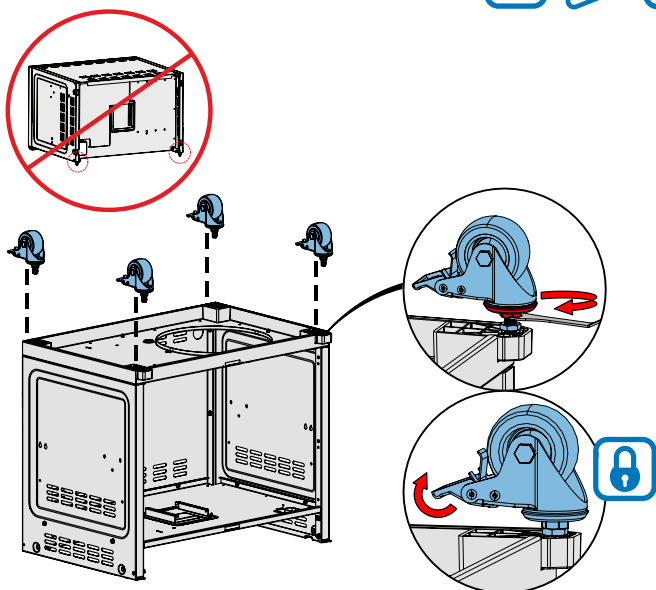

11

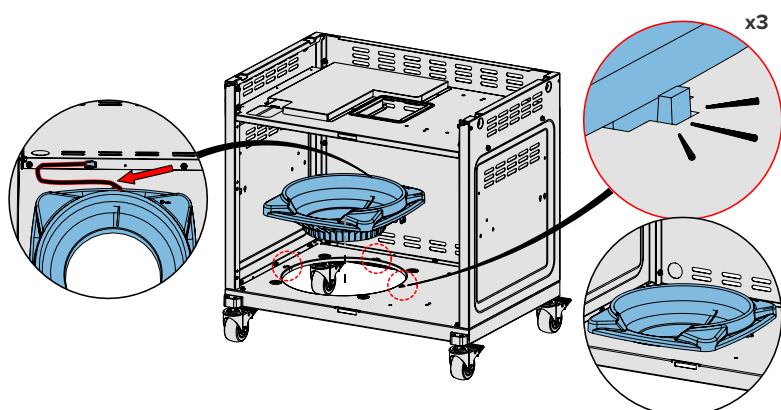

- EN Ensure wires are not pinched during installation.
- FR Veiller à ce que les fils ne soient pas pincés lors de l'installation.
- ES Asegúrese de que los cables no queden aprisionados durante la instalación.

12

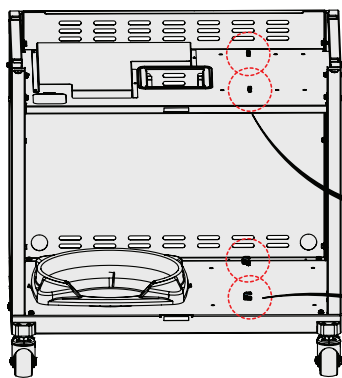

x4

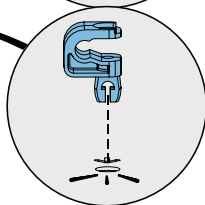
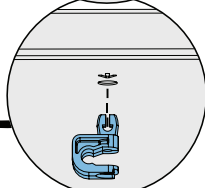
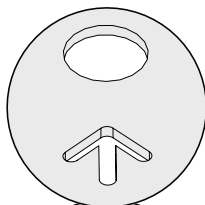

13

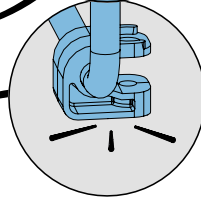
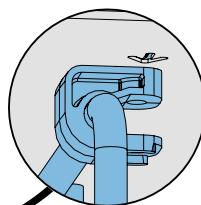
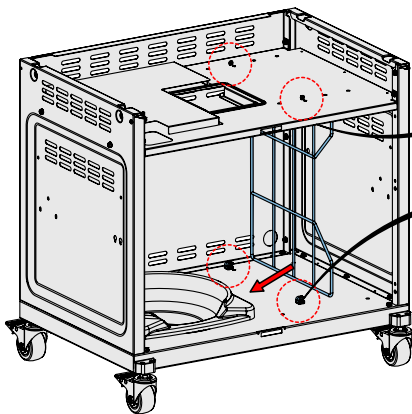

14

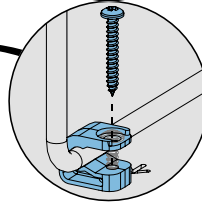
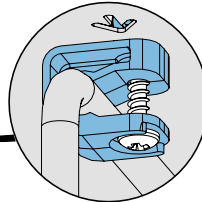
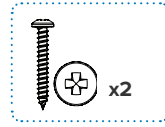
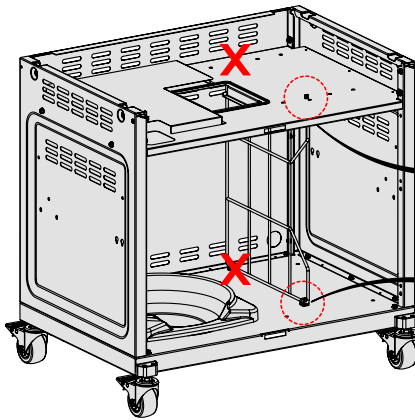

15

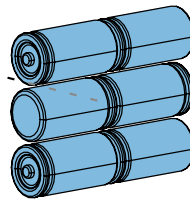
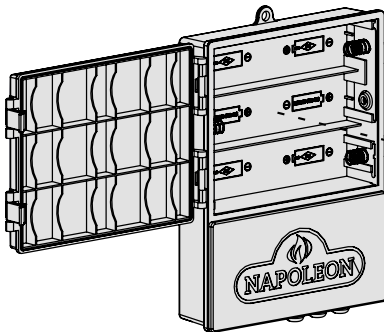
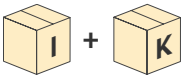

16

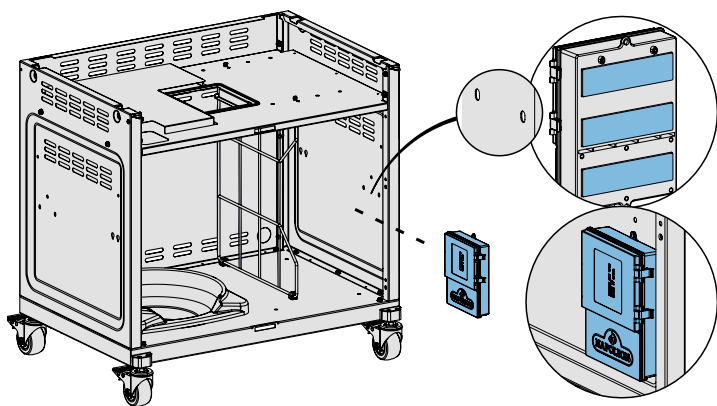

17

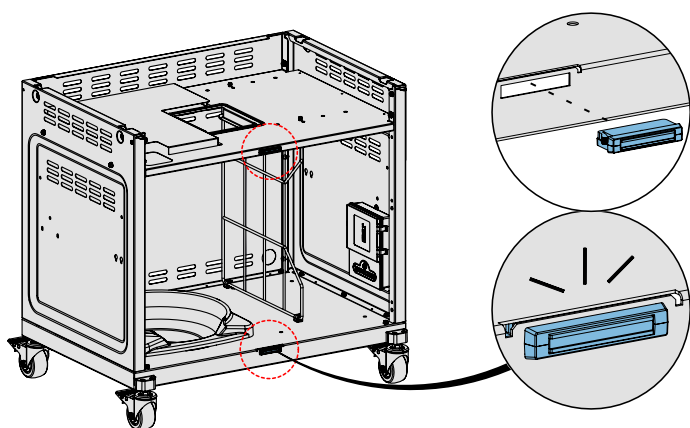

18

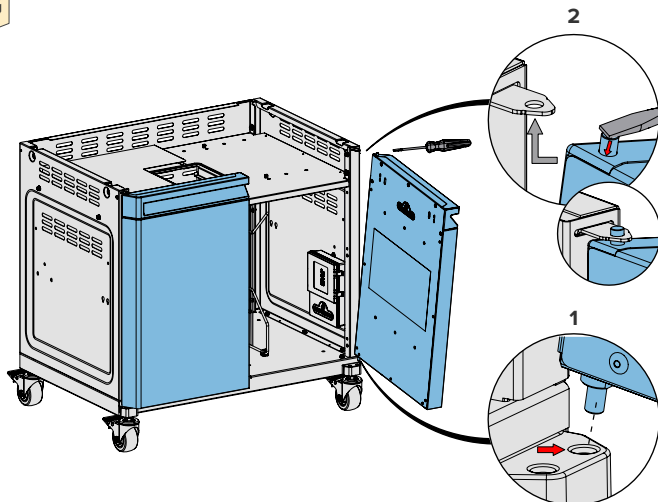

19

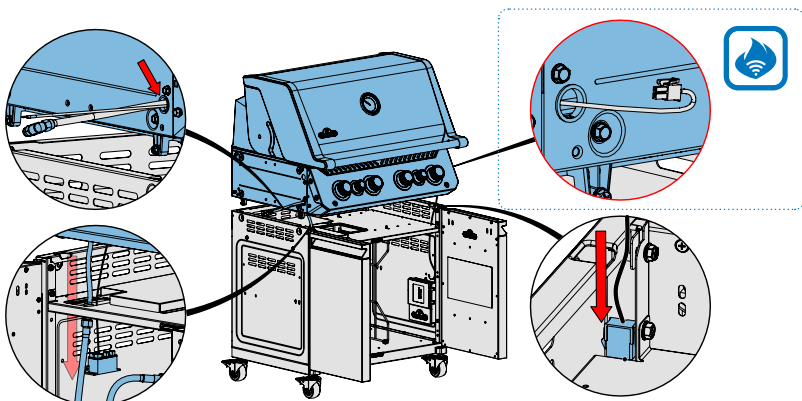
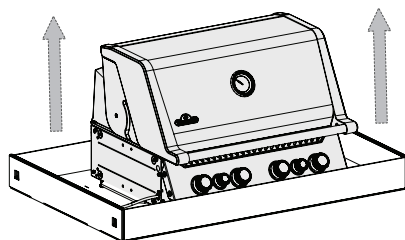

20

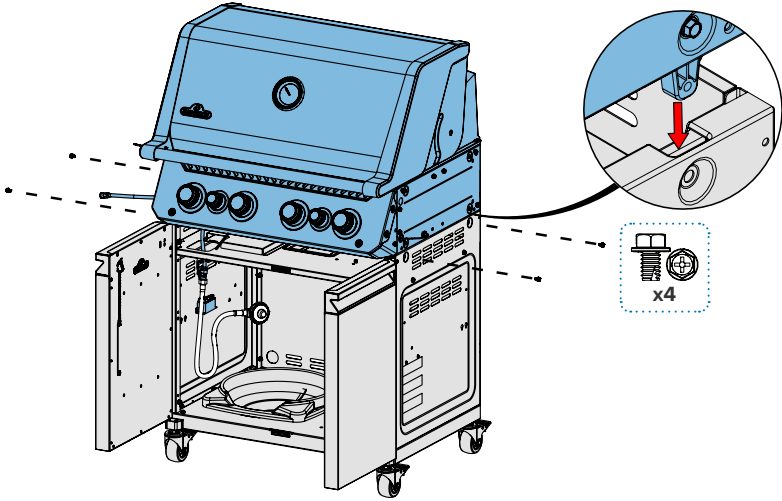

21

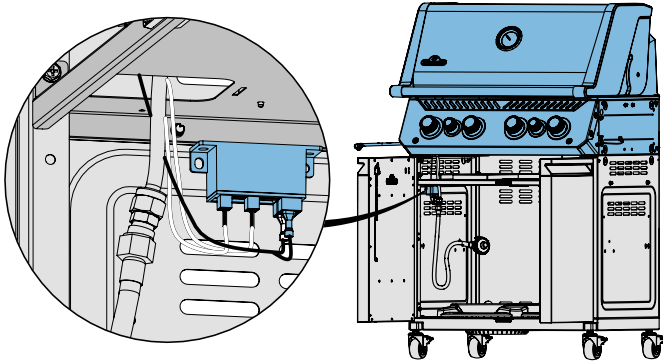

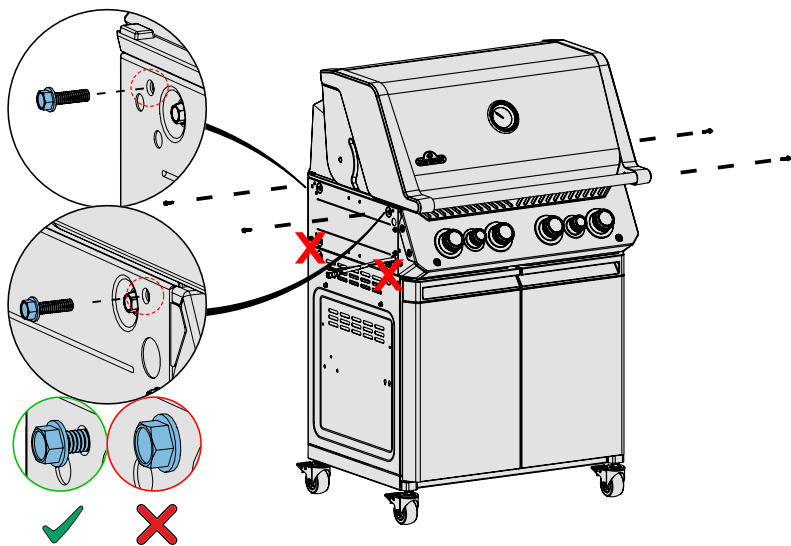
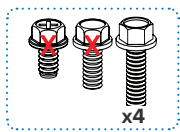

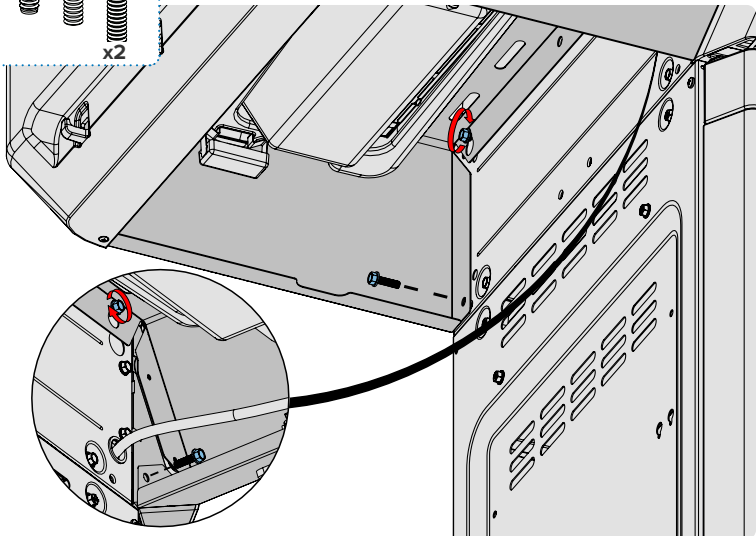
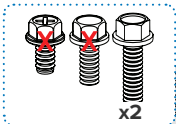
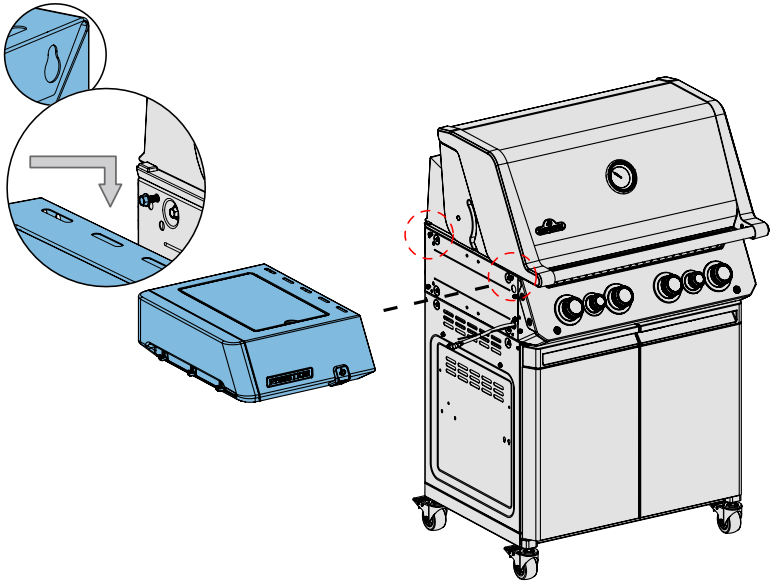

24

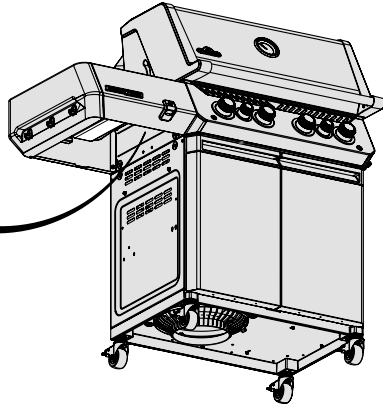
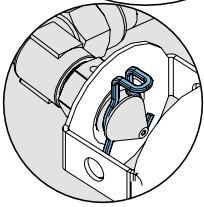
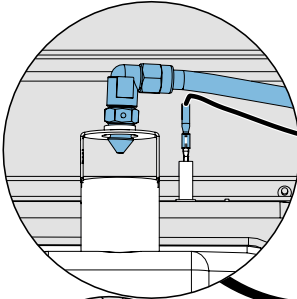

25

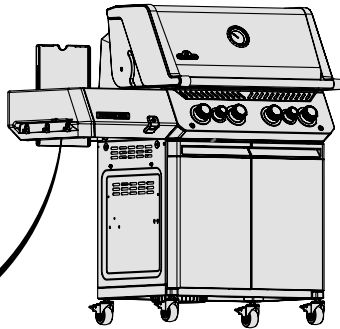
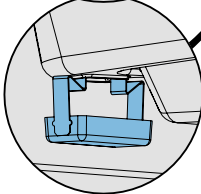
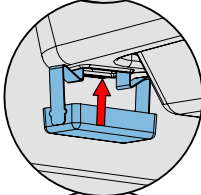
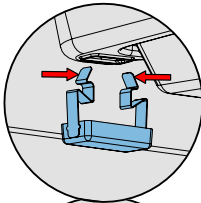

26

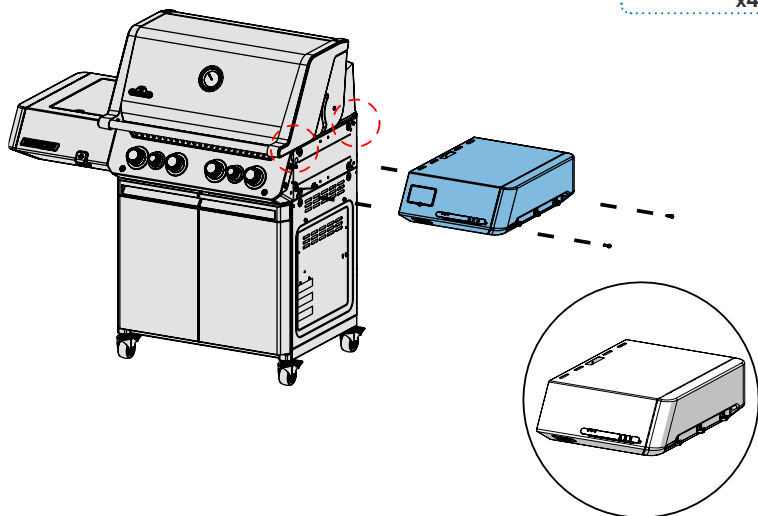
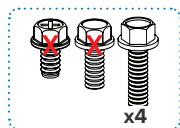

27

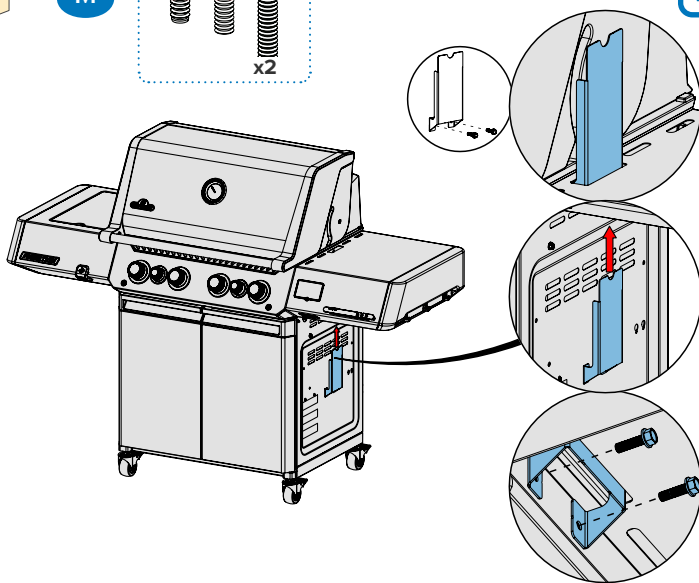
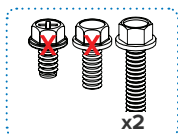

28

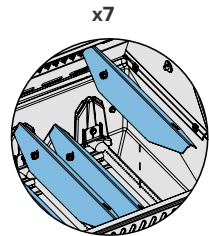
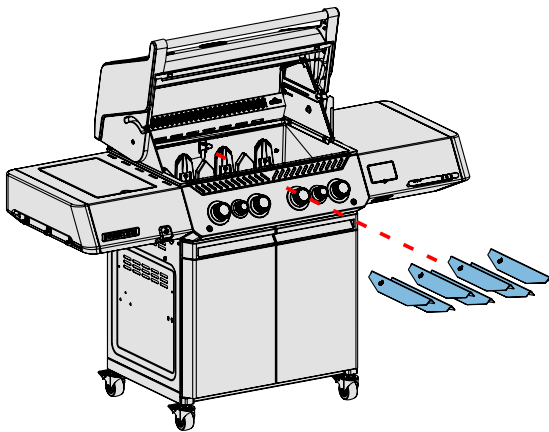

29

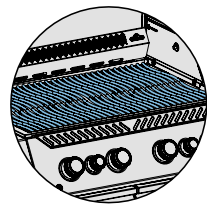
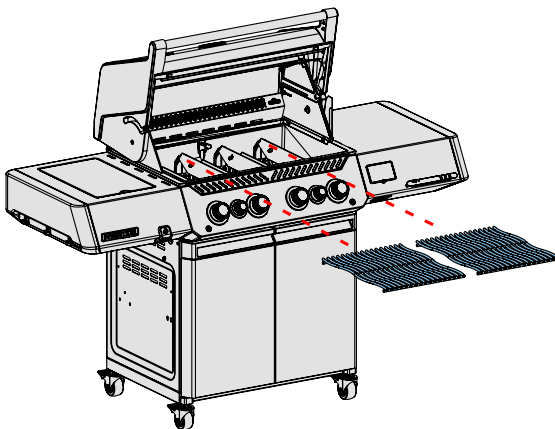

30

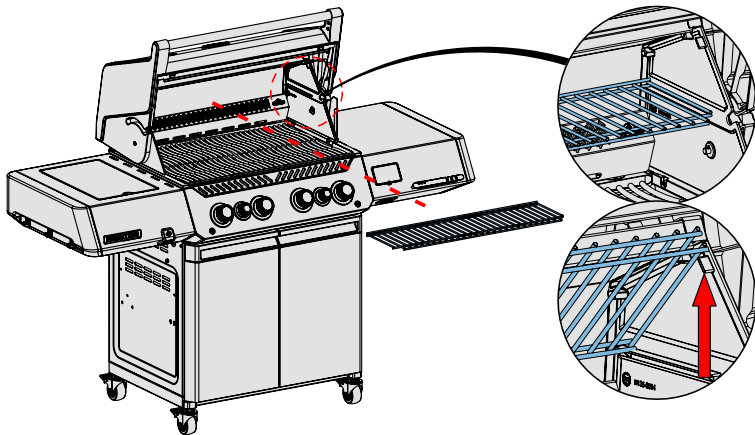

31

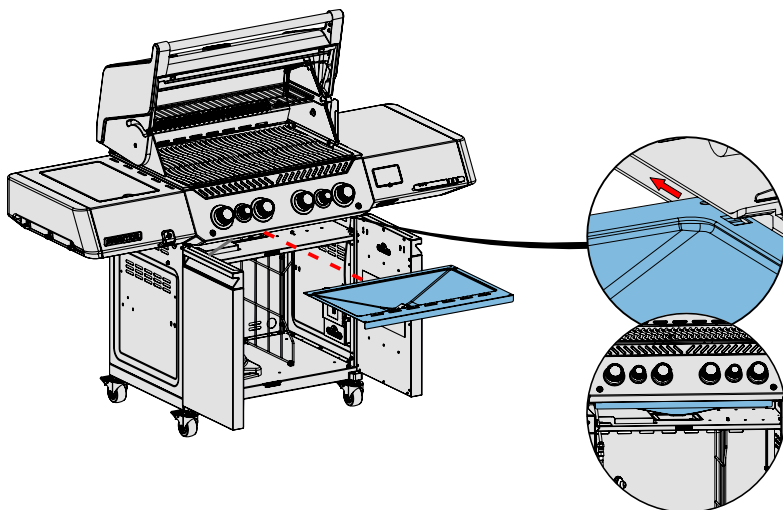
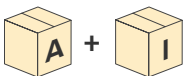

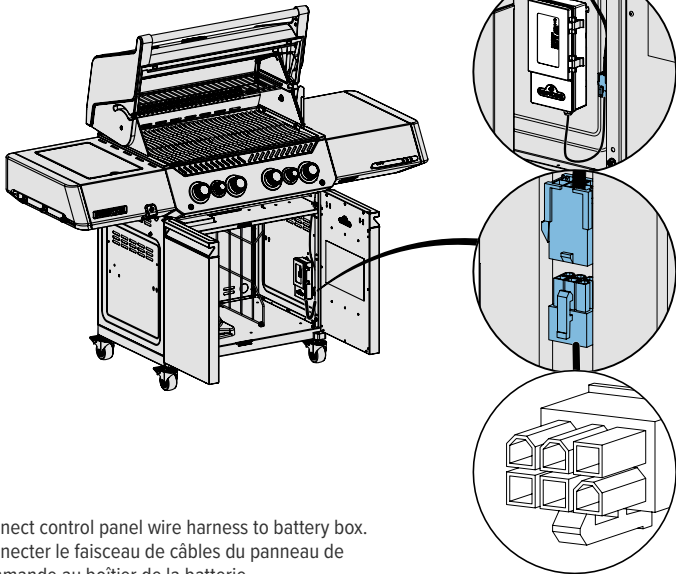

- EN Connect control panel wire harness to battery box.
- FR Connecter le faisceau de câbles du panneau de commande au boîtier de la batterie.
- ES Conecte el mazo de cables del panel de control a la caja de la batería.

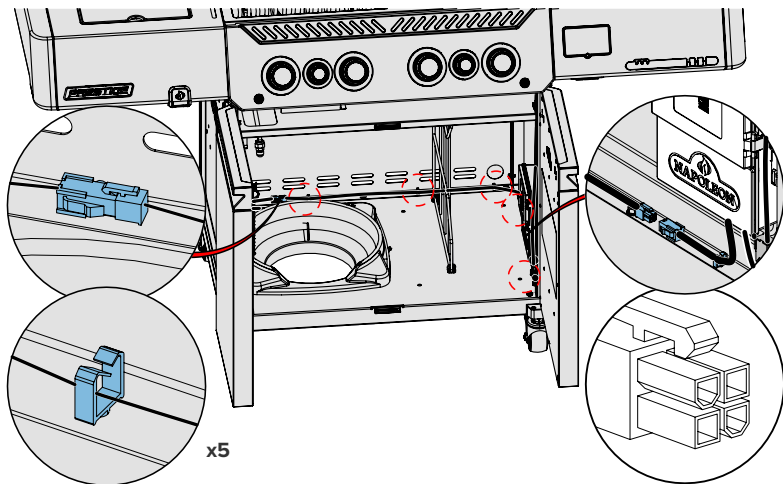

- EN Connect the tank scale wire to the battery box.
- FR Connecter le câble de la balance du réservoir au boîtier de la batterie.
- ES Conecte el cable de la escala del depósito a la caja de la batería.

34

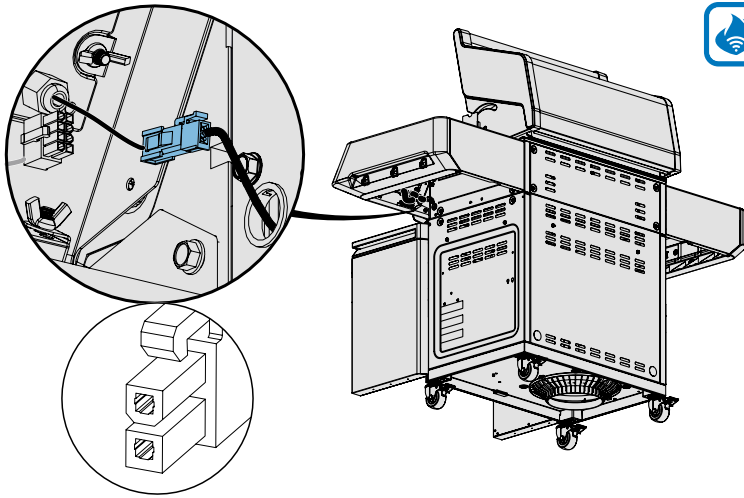

- (EN)** Connect wire to LCD screen.
- (FR)** Connecter le câble à l'écran LCD.
- (ES)** Conectar el cable a la pantalla LCD.

35

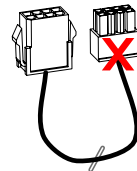
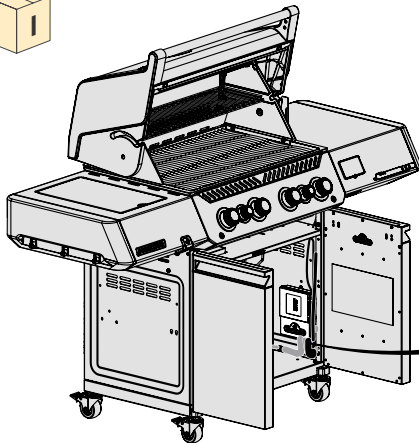

- (EN)** Locate your wireharness, connect the female plug to the power box.
- (FR)** Localisez votre faisceau de câbles, connectez la fiche femelle au boîtier électrique.
- (ES)** Localice su mazo de cables, conecte el enchufe hembra a la caja de alimentación.

36

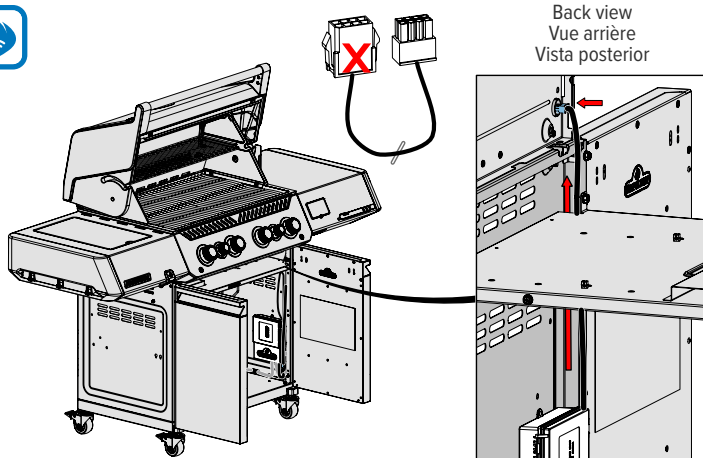

Back view
Vue arrière
Vista posterior

- EN** Take the male end of the wire, feed it up through the front channel of the side panel and through the bushing on the right side.
- FR** Prenez l'extrémité mâle du fil, faites-la passer par le canal avant du panneau latéral et par la douille sur le côté droit.
- ES** Toma el extremo macho del cable, pásalo por el canal frontal del panel lateral y por el casquillo del lado derecho.

37

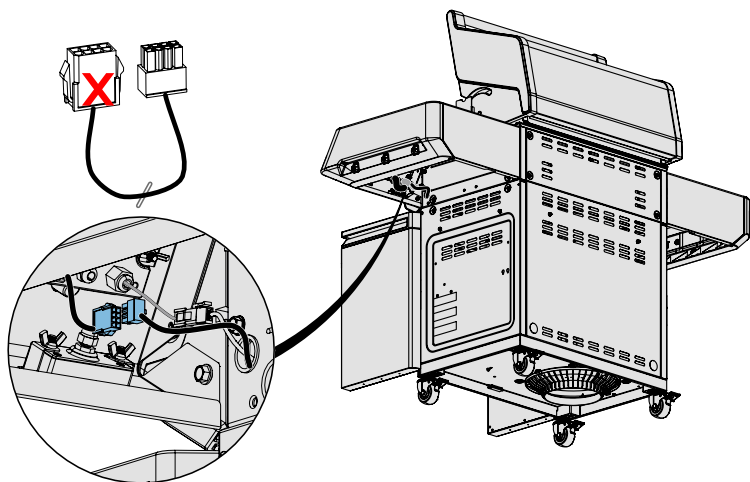

- EN** Connect the male end to the side shelf LCD screen.
- FR** Connecter l'extrémité mâle à l'écran LCD de l'étagère latérale.
- ES** Conecte el extremo macho a la pantalla LCD del estante lateral.

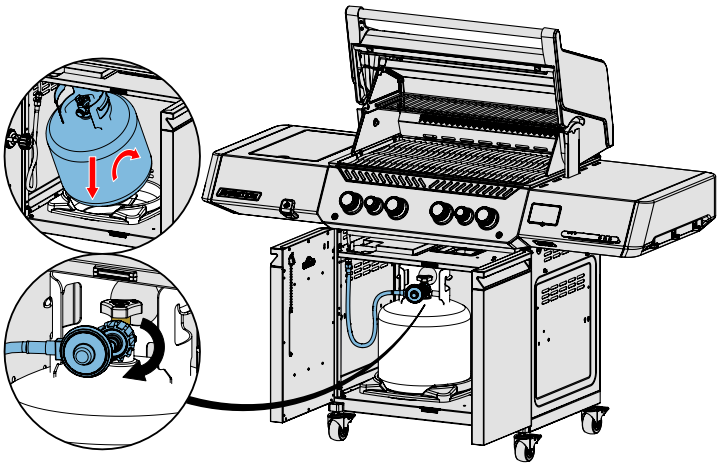
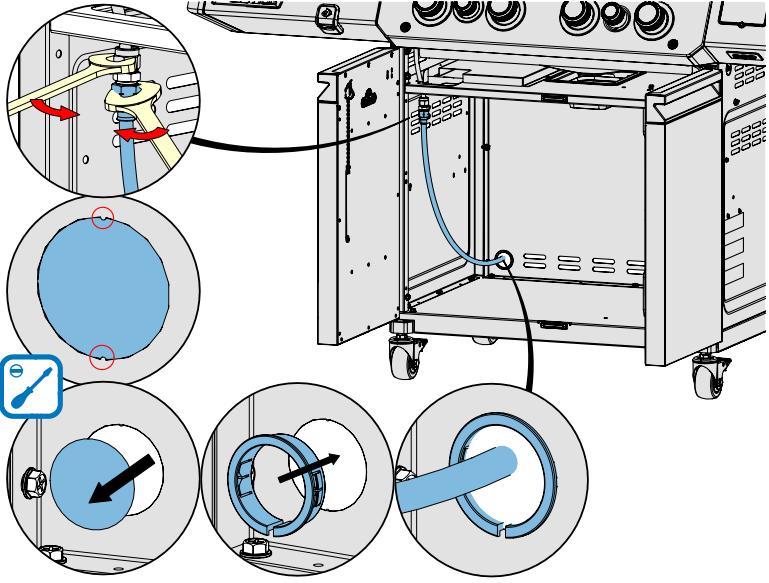

40

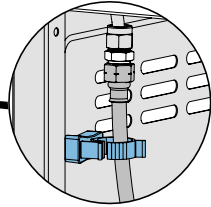
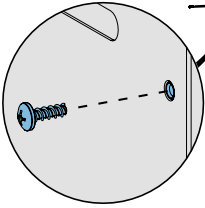
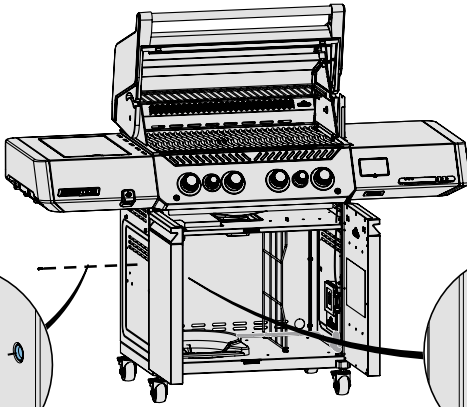
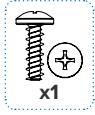

41

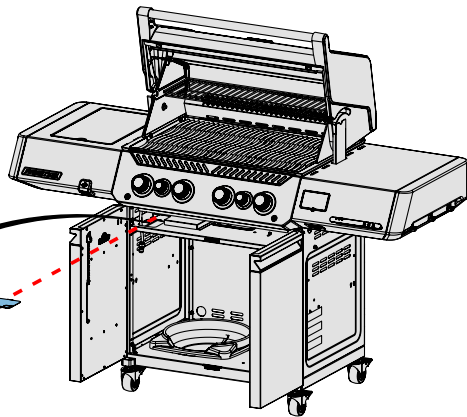
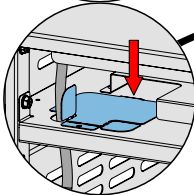
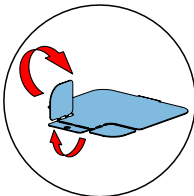

42

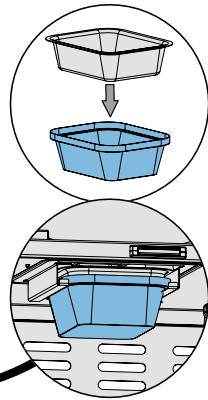
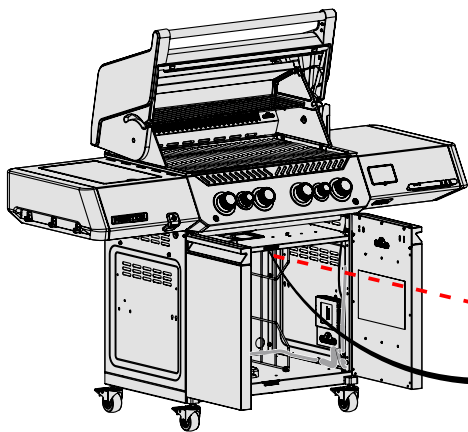

43

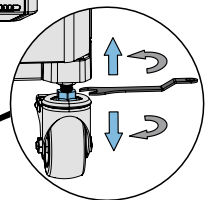
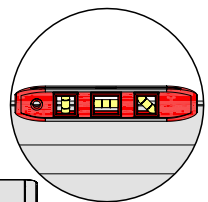
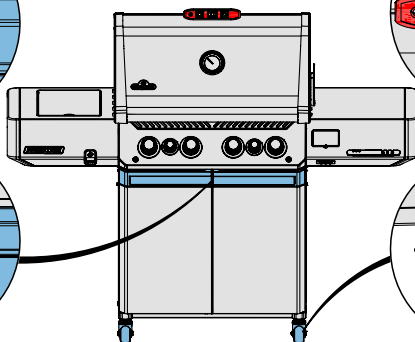
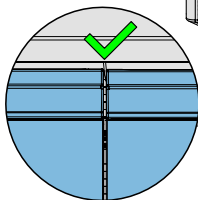
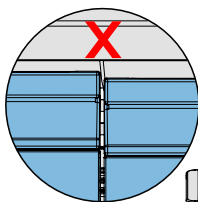

44

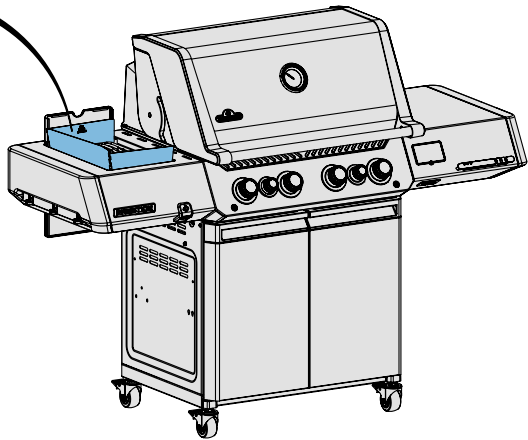
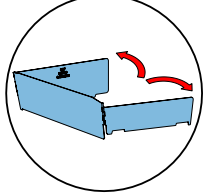
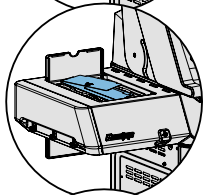
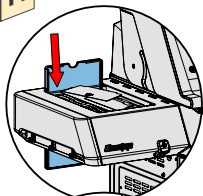

45

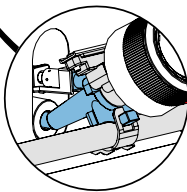
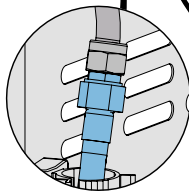
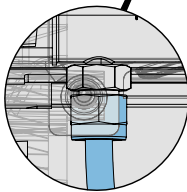
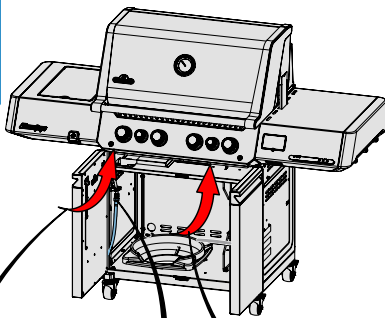
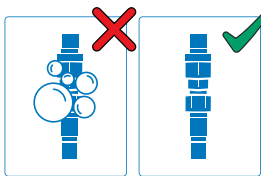

Parts List

Liste des pieces

Lista de piezas

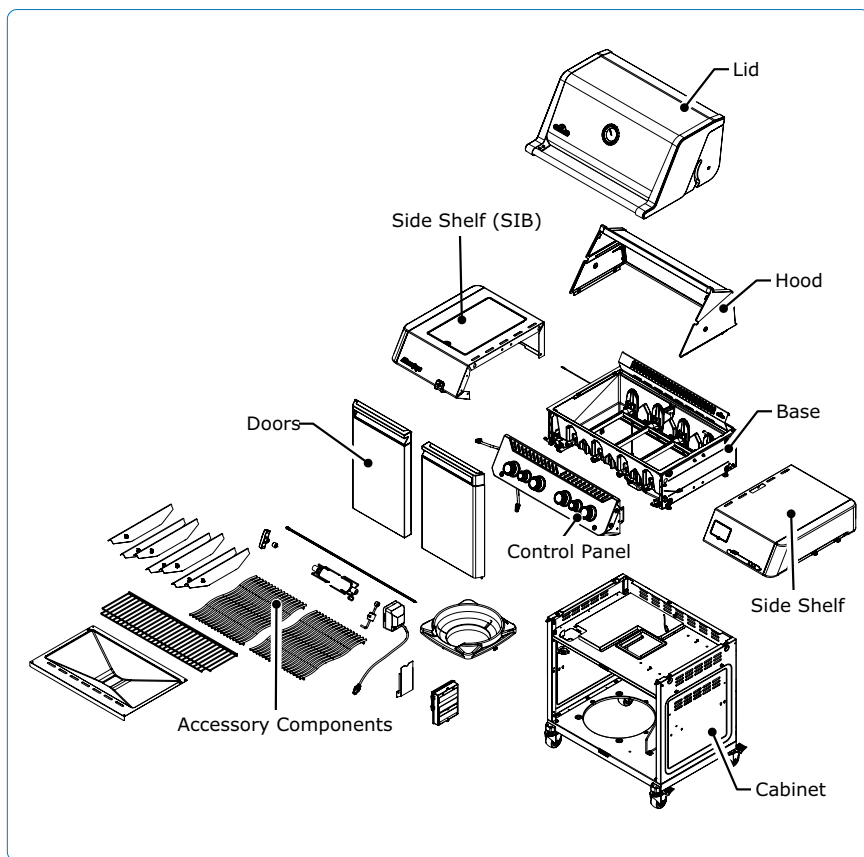

Lid Assembly | L'assemblage du couvercle | Ensamblaje de la tapa

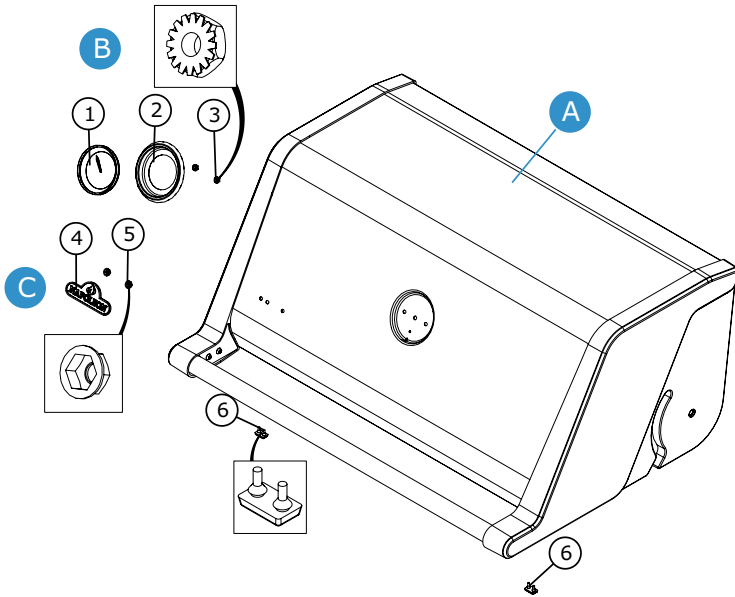

	Part # Partie # Parte #	Description Description Descripción
A	N010-1748-SER	Lid Assembly. Assemblage du couvercle. Montaje de la tapa.
B	N685-0032-BK-SER	TEMPERATURE GAUGE KIT KIT JAUGE DE TEMPÉRATUR KIT DE MEDIDOR DE TEMPERATURA
1	N685-0032-BK	Temperature Gauge Indicateur de température Indicador de temperatura
2	N051-10002238-BK1HT	Temperature Gauge Bezel Couvercle de la jauge de température Indicador de temperatura Bisel
3	N450-0032	Locknut Contre-écrou Tuerca de seguridad
C	N010-1744-SER	LOGO KIT KIT LOGO KIT DE LOGOTIPOS
4	N385-0532-BK	Logo, Napoleon® Logo, Napoleon® Logotipo, Napoleon®
5	N450-0044	Nut Écrou Tuerca
6	N510-0013	Lid Bumper Butoir du couvercle. Tope de la tapa

Hood Assembly
 Assemblage du capot
 Montaje de la campana

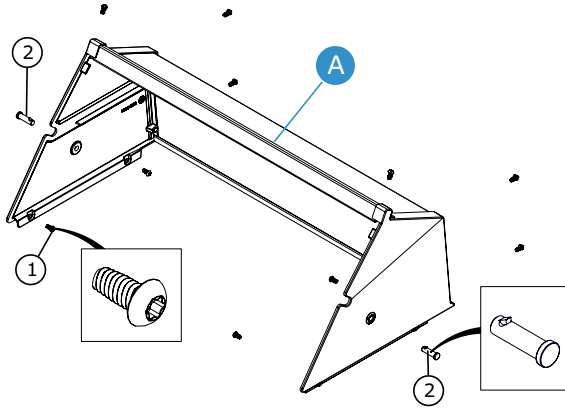

	Part # Partie # Parte #	Description Description Descripción
A	N010-1745-SER	Hood Assembly Assemblage du capot Montaje de la campana
1	N570-0145-BK	Screw 1/4-20 x 1/2 in. Vis 1/4-20 x 1/2 in. Tornillo 1/4-20 x 1/2 in.
2	N485-0033	Pin, Clevis Locking Goupille de verrouillage de chape Perno, bloqueo de horquilla

Side Shelf (Infrared Burner)
 Tablette latérale (brûleur infrarouge)
 Estante lateral (quemador de infrarrojos)

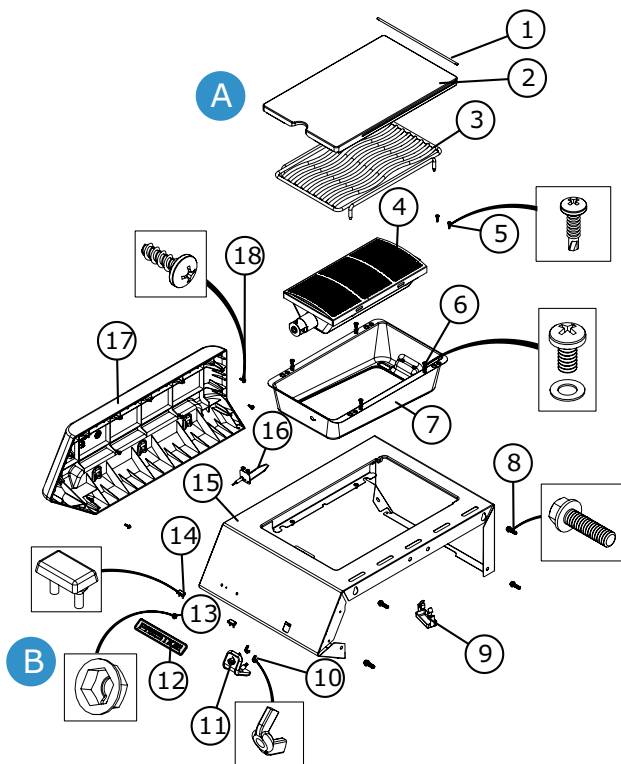

	Part # Partie # Parte #	Description Description Descripción
A	N010-1710	Assy, Side Shelf Left Assemblage, tablette latérale gauche Ensamblaje, estante lateral izquierdo
1	N555-0091	Lid Pivot Rod. Tige pivotante du couvercle. Varilla pivotante de la tapa.
2	N403-10001515-BK1TX	Side Burner Lid Couvercle du brûleur latéral Tapa lateral del quemador
3	N305-10001280	Cooking Grid Side Burner STN STL. Grille, ondulée, côté IR. Rejilla, Ondulada, lado IR.
4	N010-1725	Assy, Infrared Burner Assemblage, brûleur infrarouge Ensamblaje, quemador infrarrojo

	Part # Partie # Parte #	Description Description Descripción
5	N570-0013	Screw Vis Tornillo #8 x 5/8 in ST.ST. Pan HD. Phil.
6	N570-0042, Z735-0001	Screw, 10-24 x 3/8 Rnd Hd Philip STN STL, NGZ, Washer M9 x 5mm x 0.5mm. Screw, 10-24 x 3/8 Rnd Hd Philip STN STL, NGZ, Rondelle M9x5mm x 0.5mm. Tornillo, 10-24 x 3/8 Rnd Hd Philip STN STL, NGZ, Arandela M9 x 5mm x 0.5mm.
7	N500-0079-BK2GL	Infrared Side Burner Housing Brûleur latéral infrarouge Carcasa del quemador lateral infrarrojo
8	N570-0087	Screw, 1/4-20 x 7/8 in. Vis, 1/4-20 x 7/8 in. Tornillo, 1/4-20 x 7/8 in.
9	N710-10001808	Side Burner Drip Tray Plateau d'égouttage du brûleur latéral Bandeja de goteo del quemador lateral
10	N450-0051	Nut, Wing # 10-32 Écrou à ailettes # 10-32 Tuerca de mariposa # 10-32
11	N080-0518-BK1TX	Bottle Opener, Mounted Décapsuleur, montage Abridor de botellas, montado
B	N385-10007765-BK-SER	Logo, Prestige with Nuts Logo, Prestige avec écrous Logotipo, Prestige con tuercas
12	N385-10007765-BK	Logo, Prestige 50th Anniversary. Logo, 50e anniversaire de Prestige. Logotipo, 50.º aniversario de Prestige
13	N450-0044	Nut, 3/16 Stud Écrou, boulon 3/16 Tuerca, perno 3/16
14	N510-0013	Bumper, Rectangular Pare-chocs, rectangle Parachoques, rectangular
15	N010-1717-BK	Side Shelf Left Tablette latérale gauche Estante lateral izquierdo
16	N240-10002246	Electrode, IR Side Burner Électrode, brûleur latéral IR Electrodo, quemador lateral IR
17	N120-0058-BK0TX	End Cap, Side Shelf Left Embout, tablette latérale gauche Tapa lateral izquierda
18	N570-0076	Screw, #8 x 1/2 in. Vis, #8 x 1/2 in. Tornillo, #8 x 1/2 pulg.

Base Assembly
 Assemblage de la base
 Montaje de la base

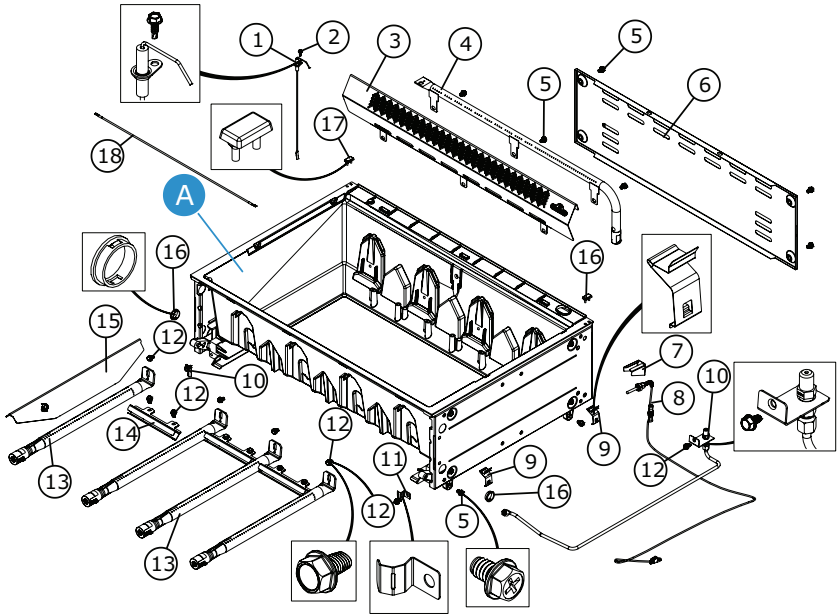

	Part # Partie # Parte #	Description Description Descripción
A	N135-0085-BK-SER	Base Assembly Assemblage de la base Montaje de la base
1	N240-0046	Rear Burner Electrode (with Wire) Électrode du brûleur arrière (avec fil) Electrodo quemador trasero (con cable)
2	N570-0008	Screw, #8 x 1/2 in. Vis, #8 x 1/2 in. Tornillo, #8 x 1/2 pulg.
3	N350-0104	Housing, Rear Burner Boîtier, brûleur arrière Carcasa, quemador trasero
3	N350-0105	Housing, Rear Burner Boîtier, brûleur arrière Carcasa, quemador trasero
4	N100-0072	Burner, Rear Brûleur, arrière Quegador trasero
5	N570-0118	Screw, 1/4 - 20x3/8 Vis, 1/4 - 20x3/8 Tornillo, 1/4 - 20x3/8

	Part # Partie # Parte #	Description Description Descripción
6	N200-0157-BK1HT	Back Cover Couverture arrière Cubierta trasera
7	N585-0192	Thermocouple Heat Shield Bouclier thermique du thermocouple Escudo térmico del termopar
8	N680-0002	Thermocouple, (with Wire) Thermocouple, (avec fil) Termopar, (con cable)
9	N160-0056	Spring Clip Clip à ressort Clip de resorte
10	N010-1720	Assy, Rear Burner Orifice Assy, Orifice du brûleur arrière Ensam, Orificio quemador trasero P500V LPG
	N010-1721	Assy, Rear Burner Orifice Orifice du brûleur arrière Orificio quemador trasero P500V NAT.
11	N160-0058 N570-0122	Bracket & Screw Support et vis Soporte y tornillo
12	N570-0122	Screw Vis Tornillo 1/4 -20 x 10.5 mm
13	N100-0071	Burner, Main Tube Brûleur, tube principal Quemador, tubo principal
14	N080-0406	Bracket, Cross Light Support, éclairage transversal Soporte, luz de cruce
15	N500-0080	Sear Plate Plaque d'araignée, biseautée Placa de cizalla, biselada
16	N105-0023	Bushing 7/8 in Douille 7/8 in. Casquillo 7/8 pulg.
17	N510-0013	Bumper, Lid Pare-chocs, Couvercle Paragolpes, Tapa
18	N750-1117	Wire, Side Burner Ignitor. Fil, allumage du brûleur latéral. Cable, ignitor quemador lateral.

Side Shelf | Tablette latérale | Estante lateral

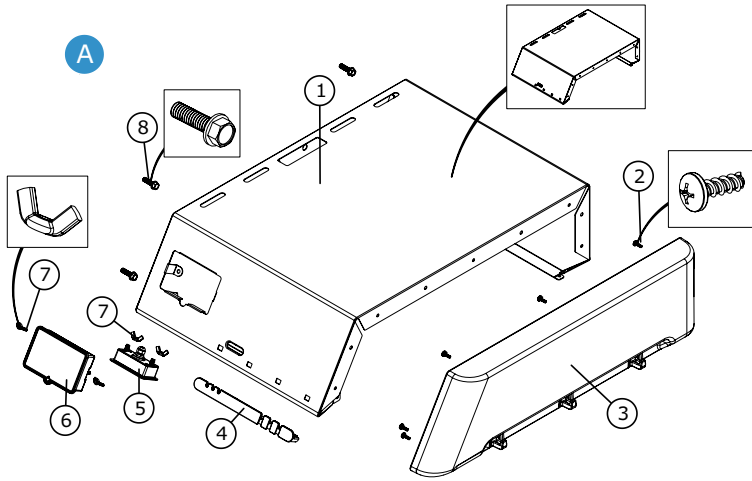

	Part # Partie # Parte #	Description Description Descripción
A	N010-1711	Assy, Side Shelf Right Assemblage, tablette latérale droite Ensamblaje, estante lateral derecho
A	N010-1712	Assy, Side Shelf Right Assemblage, tablette latérale droite Ensamblaje, estante lateral derecho
1	N010-1718	Welded Side Shelf Right Tablette latérale soudée à droite Estante lateral soldado a la derecha
1	N010-1719-BK	Welded Side Shelf Right Tablette latérale soudée à droite Estante lateral soldado a la derecha
2	N570-0076	Screw Vis Tornillo #8x1/2 in.
3	N120-0059-BK0TX	End Cap, Side Shelf Right. Capuchon, tablette latérale droite. Tapa, estante lateral derecho.
4	N710-10002247-BK0TX	Tray, Side Shelf, Probe. Plateau, étagère latérale, sonde. Bandeja, estante lateral, sonda.
5	N460-0004	Receptacle, Probe Plugs. Réceptacle, bouchons de sonde. Receptáculo, conectores de sonda.
6	N010-1738	Display Assy. Assortiment d'affichage Ensamblaje de la pantalla
7	W450-0051	Nut, Wing #10-32. Écrou à ailettes #10-32. Tuerca de mariposa #10-32.
8	N570-0087	Screw, 1/4-20 x 7/8 in. Vis, 1/4-20 x 7/8 in. Tornillo, 1/4-20 x 7/8 pulg.

Control Panel | Panneau de contrôle | Panel de control

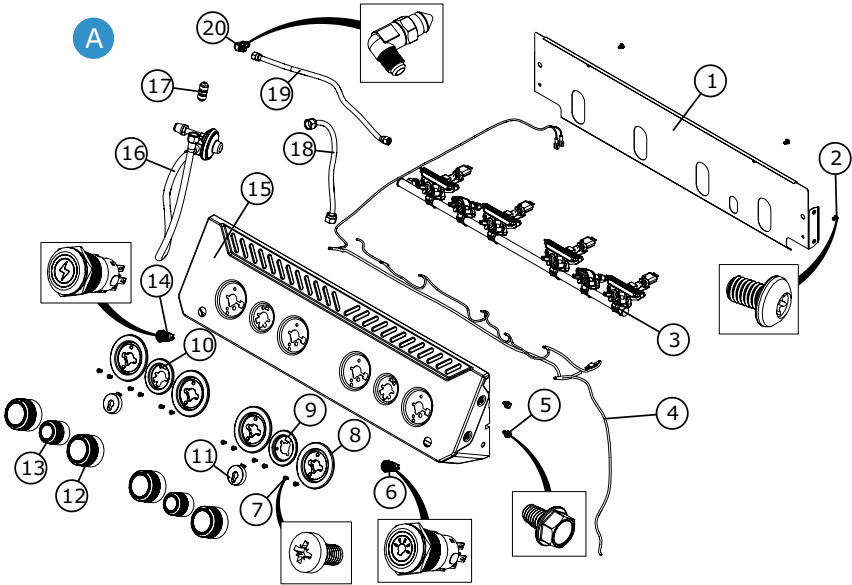

	Part # Partie # Parte #	Description Description Descripción
A	N010-1742-LP-SER	Control Panel Assy. Panneau de commande
A	N010-1742-NG-SER	Panel de control
1	N585-0193	Shield, Heat Control Panel. Bouclier, panneau de contrôle de la chaleur. Escudo, panel de control térmico.
2	N570-0148	Screw, 10-32 x 5/16 in. Vis, 10-32 x 5/16 in. Tornillo, 10-32 x 5/16 pulg.
3	N432-0023	Manifold, P500V(X) RSIB LPG Collecteur, P500V(X) RSIB LPG Colector, P500V(X) RSIB LPG
3	N432-0024	Manifold, P500V(X) RSIB NAT. Collecteur, P500V(X) RSIB NAT. Colector, P500V(X) RSIB NAT.
4	N010-1726	Control Panel Wire Harness. Harnais de câbles, panneau de commande Mazo de cables del panel de control
5	N570-0122	Screw, 1/4-20 x 10.5 mm. Vis, 1/4-20 x 10.5 mm. Tornillo, 1/4-20 x 10.5 mm.

	Part # Partie # Parte #	Description Description Descripción
6	N660-0014-BK	Light Switch Interrupteur de lumière Interrupitor de luz
7	N570-0078	Screw, M4 x 8 mm. Vis, M4 x 8 mm. Tornillo, M4 x 8 mm.
8	N010-1713-BK	Assy, Bezel + LED (Main Burner) Ensemble, cadre + LED (brûleur principal) Ensam, bisel + LED (quemador principal)
9	N051-10001479-BK1TX	Bezel, Small Rear Burner Cadre, petit brûleur arrière Bisel, quemador pequeño trasero
10	N051-10001478-BK1TX	Bezel, Small Rear Burner Cadre, petit brûleur arrière Bisel, quemador pequeño trasero
11	N387-0016	LED, Blue/Red Small LED, bleu/rouge petit LED, azul/rojo pequeño
12	N380-0051-BK	Knob, large main burner Bouton, grand brûleur principal Perilla, quemador grande principal
13	N380-0052-BK	Knob, Small Side/Rear Burner Bouton, petit brûleur latéral/arrière Perilla, pequeño quemador lateral/trasero
14	N660-0013-BK	Igniter Button Bouton d'allumage Botón de encendido
15	N475-0636	Panel, Control Panneau de contrôle Panel de control
16	N530-0003	Regulator 14 in Hose Régulateur 14 in tuyau d'arrosage Regulador manguera de 14 pulg.
16	N345-0001	10ft Natural Gas Hose. Tuyau de gaz naturel de 10ft. Manguera de gas natural de 3 m.
17	N255-0026	Fitting, Union 1/2 in MF To 3/8 in MF. Raccord, union 1/2 in MF to 3/8 in MF. Racor, unión 1/2 pulg. MF a 3/8 pulg. MF.
18	N720-0044	Flex Connector, 12 x 3/8 in. Connecteur flexible, 12 x 3/8 in. Conector flexible, 12 x 3/8 pulg.
19	N720-0097	Side Burner Flex Connector 1/4 in x 17 in. Connecteur flexible pour brûleur latéral 1/4 in x 17 in. Conector flexible para quemador lateral 1/4 pulg. x 17 pulg.
20	N010-10001866	Assy, 90 Deg Fitting, SB Orifice 1.65 mm NAT. Assy, 90 Deg Fitting, SB Orifice 1.65mm NAT. Ensam, racor de 90°, orificio SB 1,65 mm NAT.
20	N010-10001865	Assy, 90 Deg Fitting, SB Orifice #56 LPG. Assy, 90 Deg Fitting, SB orifice #56 LPG. Ensamblaje, racor 90°, orificio SB #56 LPG.

Cabinet Assembly

Assemblage du cabinet

Ensamblaje del armario

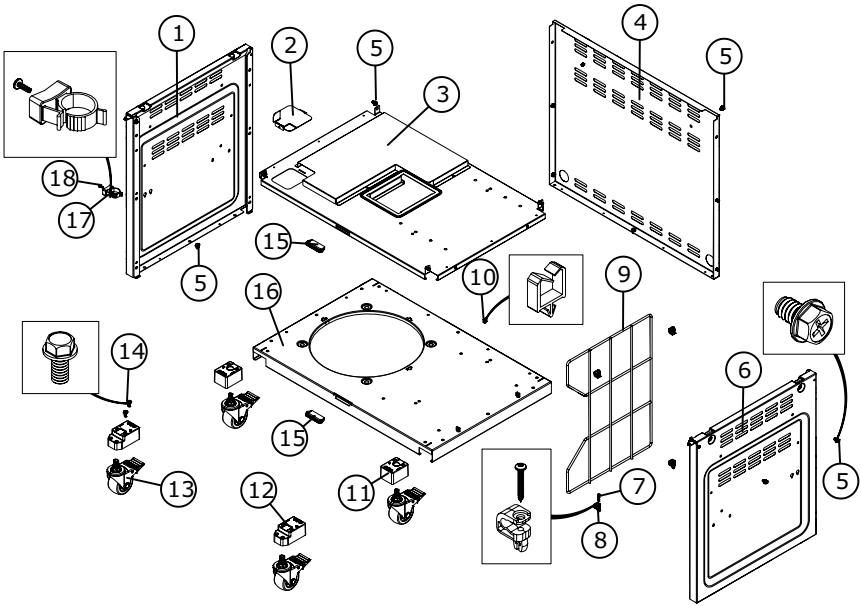

	Part # Partie # Parte #	Description Description Descripción
1	N010-1728-BX	Assy, Panel Cabinet Left Assy, panel cabinet gauche Ensamblaje, panel izquierdo
2	N200-0160-BK1TX	Cover, Heat Shield Couvercle, bouclier thermique Tapa, protección térmica
3	N585-0190-BK1TX	Shield, Heat Cart black Bouclier, cartouche thermique noir Escudo, carro térmico negro
4	N475-0633-BK1TX	Panel, Rear Cart black Panneau, arrière du chariot noir Panel, carro trasero negro
5	N570-0118	Screw Vis Tornillo 1/4-20 x 3/8 in.
6	N010-1729-BX	Assy, Panel Cabinet Right. Assy, armoire à panneaux droite. Ensamblaje, armario panel derecho
7	N570-0154	Screw, #6 x 1 in. Vis, #6 x 1 in. Tornillo, #6 x 1 pulg.

	Part # Partie # Parte #	Description Description Descripción
8	N160-0057-BK0TX	Clip, Cart Divider. Clip, séparateur de chariot. Clip, separador de carros.
9	N222-0003-BK1TX	Divider, Cart. Séparateur, chariot. Separador, carro.
10	W160-0057	Wire Clip Clip de fil Pinza para cables
11	N655-0242	Support, Caster Rear Support, crémaillère arrière Soporte, ruedas traseras
12	N655-0241-BK0TX	Support, Caster Front Support, roulette avant
12	N655-0242-BK0TX	Soporte, ruedas delanteras
13	N130-0018	Caster, 3 in Wheel, W/Brake Roulette, 3 in wheel, avec le frein Ruedas de 3 pulg., con freno
14	N570-0038	Screw, 1/4-20 x 1/2 Hex. Vis, 1/4-20 x 1/2 hexagonale Tornillo, 1/4-20 x 1/2 hexagonal
15	N430-10005373	Catch, Magnetic Loquet, magnétique Cierre magnético
16	N590-0356-BK1TX	Shelf, Bottom Cart P500V LPG black Étagère, chariot inférieur P500V LPG noir Estante, carro inferior P500V LPG negro
16	N590-0357-BK1SG	Shelf, Bottom Cart P500V NAT black Étagère, chariot inférieur P500V NAT noir. Estante, carro inferior P500V NAT negro
17	N160-0053	Clip, Flex Line Adjustable. Clip, flex ligne réglable. Clip, línea flexible ajustable.
18	Z570-0043	Screw, #8 x 3/8 in Black. Vis, #8 x 3/8 in noir. Tornillo, #8 x 3/8 in, negro.

Accessory Components
 Composants auxiliaires
 Componentes auxiliares

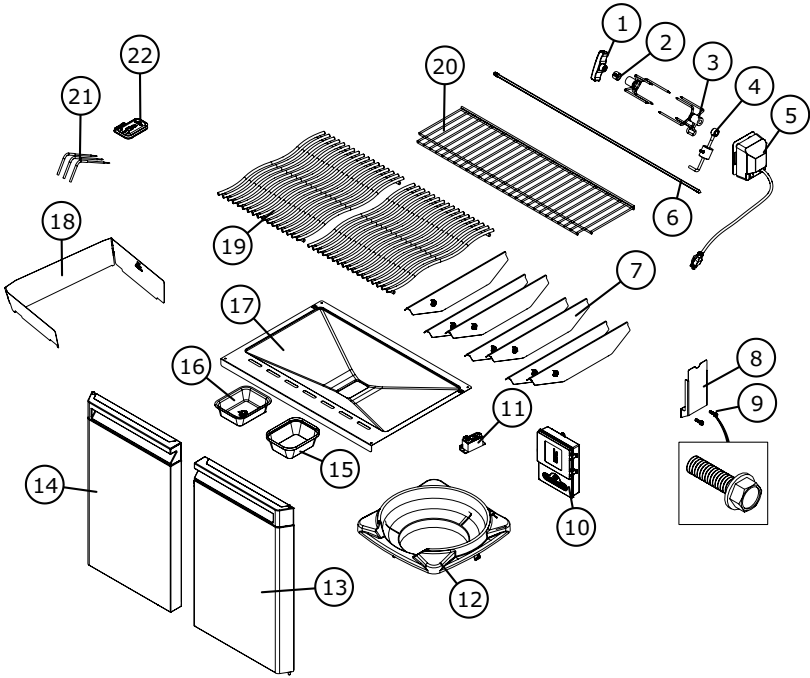

	Part # Partie # Parte #	Description Description Descripción
1	N325-0079	T Handle Plastic For Spit Rod Poignée en T en plastique pour crachoir Mango en T de plástico para caña de escupir
2	N105-0019	Bushing, Stop Douille, butée Casquillo, Tope
3	N275-0001	Rotisserie Forks. Fourchettes de rôtisserie. Tenedores de asador.
4	N370-0308	Counter Balance Contre-équilibre Contrapeso
5	65011	Heavy Duty Rotisserie Motor with 6 FT. Cord Moteur robuste avec câble de rôtissage. 6 FT. Motor pesado con cable para asador 6 Pies
6	N555-0038	Spit, Rod 34in. Embout, tige 34in. Spit, Varilla 34pulg.

	Part # Partie # Parte #	Description Description Descripción
7	N500-0080	Sear Plate, Beveled Plaque d'araignée, biseauté Placa de cizalla, biselada
8	N080-10002506-BK1HT	Bracket, Mount Rotis Motor Support, montage du moteur rotatif Soporte, montaje de motor rotis
9	N570-0087	Screw, 1/4-20 x 7/8 in. Vis, 1/4-20 x 7/8 in. Tornillo, 1/4-20 x 7/8 pulg.
10	N010-1737	Battery Housing 6x D-cell. Boîtier de batterie 6x D-cell. Carcasa de batería 6x D-cell.
11	N357-0021LY	Igniter, Block 2 Spark 4.5V. Allumeur, bloc 2 spark 4.5V. Encendedor, bloque 2 chispa 4,5V.
12	N010-1716-BK	Assy, Propane Tank Scale Assemblage, Réservoir de propane échelle Ensamblaje, tanque de propano escala
13	N010-1701-BX-	Assy, Door Right Assemblage, porte droite Ensamblaje, puerta derecha
14	N010-1700-BX	Assy, Door Left Assemblage, porte gauche Ensamblaje, puerta izquierda
15	62007	Alum. Foil Grease Tray Bac à graisse en aluminium Bandeja de grasa de aluminio
16	N710-0062	Grease Tray Plateau à graisse Bandeja para grasa
17	N710-10003472-BK2GL	Drip Pan, Porcelainized Bac de récupération, porcelainé Bandeja de goteo, porcelanizada
18	N010-10001081	Side Burner Wind Shield Brûleur latéral Pare-vent Rompevientos, quemador lateral
19	N305-0157	Cooking Grid Large Stainless Steel Grande grille de cuisson, acier inoxydable Parrilla de cocción grande, acero inoxidable
20	N520-0059	Warming Rack Portoir chauffant Soporte para calentar
21	N680-0003	Thermoprobe, Wired Thermosonde, filaire Sonda térmica, con cable
22	N350-10002764	Probe Housing Boîtier de la sonde Carcasa de la sonda

50 Years of Home
Comfort Solutions.

50 ans de solutions pour le
confort de votre maison.

50 años de soluciones para
el confort del hogar.



NAPOLEON® products are protected by one or more U.S. and Canadian and/or foreign patents or patents pending.

Les produits de NAPOLEON® sont protégés par un ou plusieurs brevets américains, canadiens et/ou étrangers au par des brevets en instance.

Los productos NAPOLEON® están protegidos por una o más patentes o patentes pendientes en E.U., Canadá y/u otros países.



Address | Adresse | Dirección

Wolf Steel Ltd.

24 Napoleon Road,
Barrie, Ontario, L4M 0G8
103 Miller Drive, Crittenden,
Kentucky, USA 41030



Online | En ligne | En línea



www.napoleon.com



Scan code for additional
information.

Scannez le code pour
obtenir des informations
supplémentaires.

Escanee el código para
obtener información
adicional.