

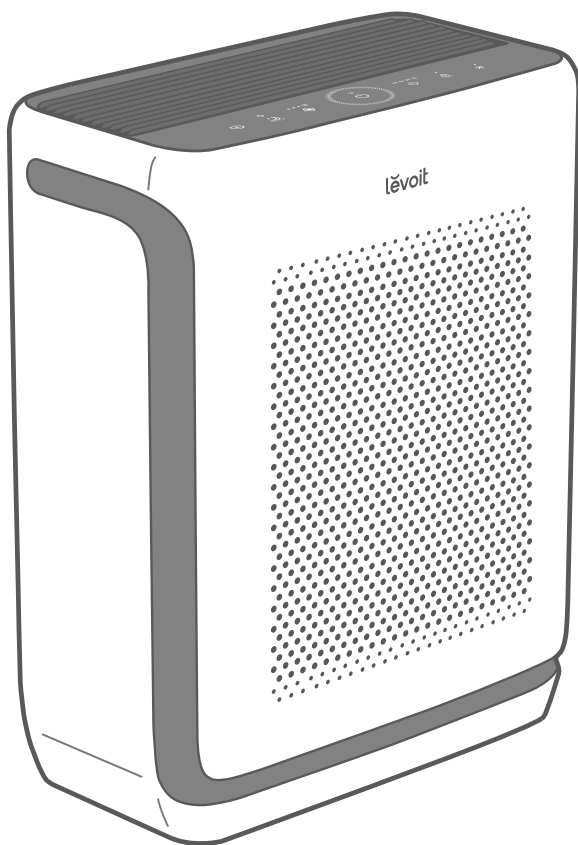

USER MANUAL

Vital 200S-P Smart Air Purifier



Questions or Concerns?

Please contact us Mon–Fri, 9:00 am–5:00 pm PST/PDT at support@levoit.com or at **1-888-726-8520**.

Table of Contents

Package Contents	2
Specifications	2
Safety Information	3
Getting to Know Your Smart Air Purifier	5
Controls & Display	6
Getting Started	7
Using Your Smart Air Purifier	10
About the Filter	15
Care & Maintenance	17
Troubleshooting	21
Warranty Information	25
Customer Support	27

Package Contents

1 x Smart Air Purifier
1 x Pre-installed Washable Pre-Filter
1 x Pre-installed Main / Activated Carbon Filter
1 x User Manual
1 x Quick Start Guide
1 x AC Power Adapter

Specifications

Model	LAP-V201S-WUS, LAP-V201S-KUS
Power Supply	24V \equiv 2.5A
Rated Power	51W
Operating Conditions	Temperature: 14°–104°F / -10°–40°C
	Humidity: \leq 85% RH
Dimensions	15.6 x 8.5 x 19.8 in / 39.6 x 21.7 x 50.2 cm
Weight	13.2 lb / 6 kg
Power Adapter	Input: 100–240V \sim 50/60Hz 1.5A Max Output: 24V \equiv 2.5A

Note: To access additional smart functions, download the free VeSync app (see page 9).

READ AND SAVE THESE INSTRUCTIONS

SAFETY INFORMATION

To reduce the risk of fire, electric shock, or other injury, follow all instructions and safety guidelines.

General Safety

- **Only** use your air purifier as described in this manual.
- **Do not** use without removing the plastic wrap from the filter. The air purifier will not filter air and may overheat, causing a fire hazard.
- **Do not** use your air purifier outdoors.
- Keep your air purifier away from water, and wet or damp areas. **Never** place in water or liquid.
- **Do not** use in excessively humid areas.
- Keep your air purifier away from heat sources.
- **Do not** use where combustible gases, vapors, metallic dust, aerosol (spray) products, or fumes from industrial oil are present.
- Keep 5 ft / 1.5 m away from where oxygen is being administered.
- Children should be supervised to ensure that they **do not** play with the air purifier.
- **Do not** allow children to play with the plastic packaging. Immediately discard the plastic after unwrapping the filter.
- **Do not** place anything into any opening on the air purifier.
- Children should be supervised to ensure they **do not** insert fingers or objects into the vent openings.
- **WARNING:** To Reduce The Risk Of Fire, Electric Shock Or Injury To Persons, Do Not Use Replacement Parts That Have Not Been Recommended By The Manufacturer (e.g. Parts Made At Home Using A 3D Printer).
- **Do not** sit or place heavy objects on the air purifier.
- Keep the inside of the air purifier dry. To prevent moisture buildup, avoid placing in rooms with major temperature changes.
- **Always** unplug your air purifier before servicing ,cleaning or any other maintenances(such as changing the filter).
- **Do not** use your air purifier if it is damaged or not working correctly, or if the cord or plug is damaged. **Do not** try to repair it yourself. Contact **Customer Support** (see page 27).
- **WARNING:** To reduce the risk of fire or electric shock, **do not** use this air purifier with any solid-state speed controls (such as a dimmer switch).
- Children should not clean or perform maintenance on the air purifier without supervision.
- This air purifier is not to be used by persons (including children) with reduced physical, sensory, or mental capacities, or lack of experience and knowledge, unless they have been given supervision or instruction concerning the use of the appliance by a person responsible for their safety.
- Not for commercial use. Household use **only**.

SAFETY INFORMATION (CONT.)

Power Adapter & Cord

- Keep the air purifier near the outlet it is plugged into.
- **Never** place the cord near any heat source.
- **Do not** cover the cord with a rug, carpet, or other covering. **Do not** place the cord under furniture or appliances.
- Keep the cord out of areas where people walk often. Place the cord where it will not be tripped over.
- This air purifier is **only** to be used with the power supply adapter provided with the air purifier
- If the power adapter cord is damaged, it must be replaced by Arovast Corporation or similarly qualified persons in order to avoid an electric or fire hazard. Please contact **Customer Support** (see page 27).
- This air purifier's power adapter uses standard North American 120V, 60Hz outlets. If using outside the US or Canada, check for compatibility.
- Unplugging the power adapter will disable remote control of the air purifier and temporarily disconnect the air purifier from VeSync and other third-party apps.

Electromagnetic Fields (EMF)

Your Levoit air purifier complies with all standards regarding electromagnetic fields (EMF). If handled properly and according to the instructions in this user manual, the appliance is safe to use based on scientific evidence available today.

GETTING TO KNOW YOUR SMART AIR PURIFIER

- A. Check Filter Indicator
- B. Fan Speed Indicators
- C. On/Off Button
- D. Wi-Fi® Indicator
- E. Timer Indicators
- F. Display Lock Indicator
- G. Light Sensor
- H. Auto Mode Button
- I. Sleep Mode Button
- J. Fan Speed Button
- K. Air Quality Indicator
- L. Timer Button
- M. Display Lock Button
- N. Display Off Button
- O. Front Cover
- P. Washable Pre-Filter
- Q. Main / Activated Carbon Filter
- R. AirSight™ Infrared Dust Sensor
- S. Dust Sensor Cover
- T. Power Adapter Input
- U. Power Adapter

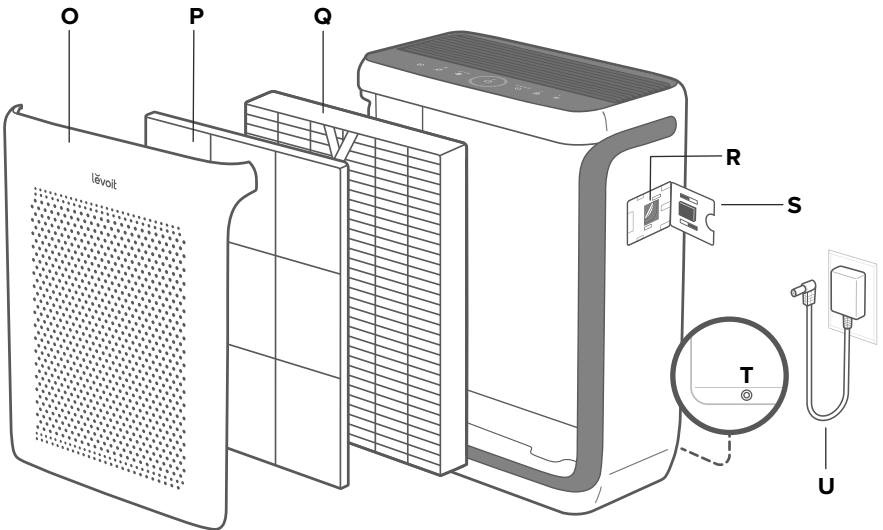
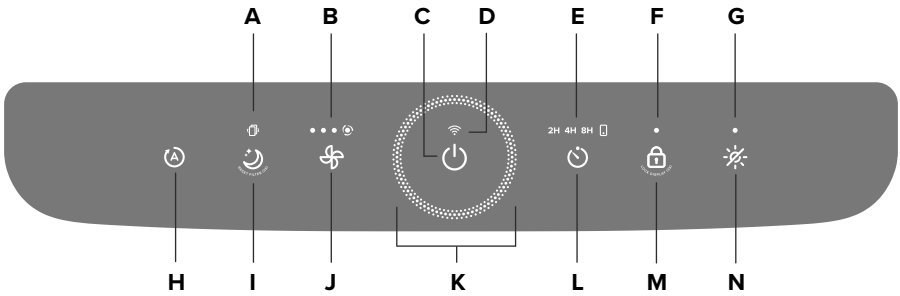

CONTROLS & DISPLAY

Note: You can also use the VeSync app to control these functions, as well as additional app-only features (see page “VeSync App Functions” on page 13).



Auto Mode Button

- Turns Auto Mode on (see page 10).



Sleep Mode Button

- Turns Sleep Mode on (see page 10).
- Press and hold for 3 seconds to reset the Check Filter Indicator.



Check Filter Indicator

- Lights up red when the filter should be checked (see **Check Filter Indicator**, page 17).
- To reset the Check Filter Indicator, press and hold  for 3 seconds. The Check Filter Indicator will flash 3 times, and turn off.



Fan Speed Button & Indicators

- Cycles through fan speeds: low (1 indicator will light up), medium (2 indicators), high (3 indicators), and turbo (4 indicators).
- Tapping  while the air purifier is in Auto Mode, Sleep Mode, or Pet Mode (when the display is lit up) will exit that mode.



Air Quality Indicator

- These indicator rings use an automatic infrared dust sensor to display the air quality: Blue (Very Good), Green (Good), Orange (Moderate), Red (Bad).



On/Off Button

- Turns the air purifier on/off.
- Press and hold for 5 seconds to connect the air purifier to the VeSync app. See the in-app instructions for more information (see page 9).
- Press and hold for 15 seconds to reset the air purifier and disconnect from Wi-Fi® (see page 9).



Wi-Fi Indicator

- Blinks when connecting to the VeSync app, lights up when connected to VeSync, and is off when disconnected from VeSync. See the VeSync in-app instructions for more information (see page 9).



Timer Button & Indicators

- Cycles through timer options: 2 hours, 4 hours, and 8 hours (see page 11).

Note: The timer indicators will light up with the corresponding timer selected.

-  lights up when the timer function is used through the VeSync app.

CONTROLS & DISPLAY (CONT.)



Display Lock Button & Indicator

- Prevents current settings from being changed (see page 12). Press and hold for 3 seconds to lock and unlock the display.

Note: Display Lock can also be controlled through the VeSync app.

- The Display Lock Indicator will light up when the display is locked and blink when any other button is tapped to indicate the display is locked.



Display Off Button

- Turns the display off (see page 11).
- Tap any button to turn the display back on.



Light Sensor

- The Light Sensor detects the amount of light in the room to automatically adjust the air purifier settings (see **Light Detection**, page 11).
- Light Detection can be turned on/off in the VeSync app (see page 11).
- Press and hold display button for 3 seconds also turns on/off the light detection function.

GETTING STARTED

1. Place the air purifier on a flat, stable surface such as the floor.
2. Pull both sides of the front cover to remove it. *[Figure 1.1]*

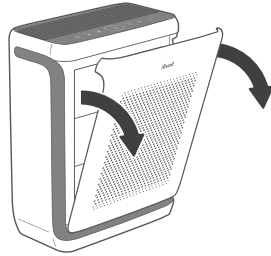

Figure 1.1

3. Push the pre-filter's tabs inward and pull to remove the pre-filter from the air purifier. *[Figure 1.2]*

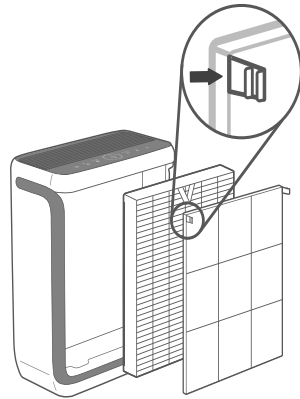

Figure 1.2

GETTING STARTED (CONT.)

4. Remove the Main / Activated Carbon Filter from inside the air purifier.
5. Remove the plastic packaging from the filter and place the filter and the pre-filter back into the air purifier. *[Figure 1.3]*

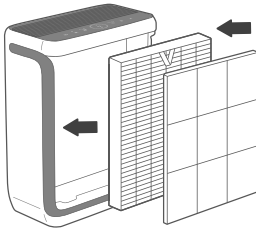
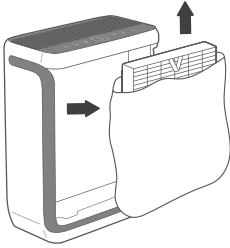

Figure 1.3

Note: Make sure the Main filter (the side with the ribbon handle) is facing outward when you insert the filter. *[Figure 1.4]*

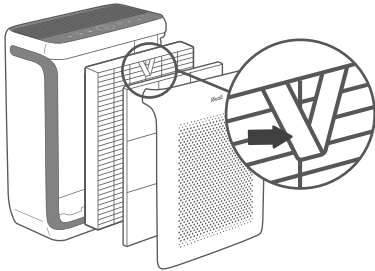

Figure 1.4

6. Place the front cover on the air purifier. Make sure to align the tabs on the cover with the slots on the bottom of the air purifier. *[Figure 1.5]*

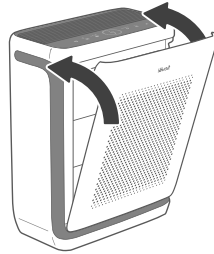

Figure 1.5

7. Insert the power adapter plug into the back of the air purifier. *[Figure 1.6]*

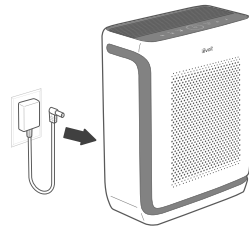

Figure 1.6

8. When using the air purifier, allow at least 15 inches / 38 cm of clearance from the front of the air purifier. Keep away from anything that would block air flow, such as curtains. *[Figure 1.7]*

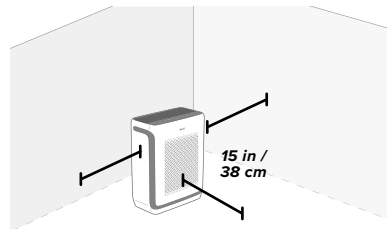

Figure 1.7

VeSync App Setup

Note: The VeSync app is continually being improved and may change over time. If there are any differences, follow the in-app instructions.

1. To download the VeSync app, scan the QR code or search "VeSync" in the Apple App Store® or Google Play Store.



Note: For Android™ users, choose "Allow" to use VeSync.

2. Open the VeSync app. **Log In** or **Sign Up**.

Note: You must create your own VeSync account to use third-party services and products. These will not work with a guest account. With a VeSync account, you can also allow your family and friends to control your smart air purifier.

3. Follow the in-app instructions to set up your smart air purifier.

Note: Your phone must have Location turned on while your phone is connecting to your smart air purifier. This is required to establish the Bluetooth® connection. You can turn Location off after your smart air purifier is finished connecting to the VeSync app.

Wi-Fi Connection

- To disconnect Wi-Fi, press and hold  for 15 seconds until the Wi-Fi indicator turns off. This will restore the smart air purifier's default settings and disconnect it from the VeSync app.
- To reconnect, please follow the instructions in the VeSync app for adding a device.



Connect with Amazon Alexa or Google Assistant™

You can use the VeSync app to connect your smart air purifier to **Amazon Alexa** or **Google Assistant™**. Please follow the in-app instructions to set up your voice assistant.

Note: You must create your own VeSync account to access voice assistants.

USING YOUR SMART AIR PURIFIER

Note: Using the VeSync app allows you to control your air purifier remotely and access additional functions and features (see page 13).

1. Plug in and tap  to turn on the air purifier. The fan will start on low.
2. Tap  to change fan speed between low, medium, high, and turbo.

Note:

- The fan speed indicators are not buttons and only display the fan speed setting.
- The fan speed indicators will light up when active, 1 indicator will light up for low, 2 for medium, 3 for high, and 4 for turbo.
- Turbo fan speed (4 indicator lights) is the loudest, but cleans air the quickest.
- For best results, or to address a specific air quality issue such as smoke, run the air purifier on turbo for 15–20 minutes before using a lower speed.
- To effectively clean air, keep windows and doors closed while the air purifier is on.

Sleep Mode

Sleep Mode operates quietly by using a fan speed lower than low speed.



1. Tap  to turn Sleep Mode on.
2. Sleep Mode will turn off the display after 6 seconds if no other buttons are tapped.
3. To switch from Sleep Mode, tap Auto Mode or select a fan speed on the air purifier's display or in the VeSync app.

Note:

- When the display is turned off, tap any button to turn the display back on. If you don't tap another button, the display will turn off again after 6 seconds.
-  will still turn on and stay on if it's time to check your filter (see page 17)

Auto Mode

Auto Mode uses AirSight™, an infrared dust sensor inside the air purifier, to adjust the fan speed automatically based on air quality. For example, if the air quality is bad, the fan will automatically be set to high speed.

1. Tap  to turn Auto Mode on.
2.  will light up while Auto Mode is on.
3. To switch from Auto Mode, tap Sleep Mode or select a fan speed on the air purifier's display or in the VeSync app.

Air Quality Indicator Chart		
Indicator Color	Air Quality	Auto Mode Fan Speed
Blue	Very Good	Sleep Mode
Green	Good	Low
Orange	Moderate	Medium
Red	Bad	High

Note:

- Auto Mode does not use the turbo fan speed.
- The VeSync app also supports Efficient Auto Mode and Quiet Auto Mode (see page 14).

USING YOUR SMART AIR PURIFIER (CONT.)

Light Detection

1. The light sensor is off by default. You can turn on/off Light Detection in the VeSync APP. You can also press and hold display button for 3 seconds to turn on/off Light Detection, and the air quality indicator blinks once when the operation is complete.
2. While the air purifier is operating, the Light sensor will detect the brightness of the room and work according to the ambient light.

Room light	Display
Dark	Display off
Light	Display on

Note:

- When the light detection on and room is in darkness, if the air purifier is in Auto Mode or Pet Mode, it will not use the high or turbo fan speed to avoid making too much noise.
- When the room becomes light again, the air purifier will return to its previous setting. The display will automatically turn back on.
- With the light detection on, if you click display off, the screen will stay off; however, you can't get the screen to stay on in a dark room.

Timer

You can manually set the timer for 2, 4, or 8 hours using the  button. You can also set the timer for 1–24 hours through the VeSync app.

Note: You can set a timer for 1–24 hours in the VeSync app.

1. Tap  repeatedly to select a time. The timer will start automatically.

Note:

- The indicators are not buttons and cannot be used to select a time.
- The timer indicators will light up blue when active.
- When the timer is set through the VeSync app, the  indicator will light up instead. Once the timer has finished, the air purifier will turn off.



2. To cancel the timer, tap  until all timer indicators are off. You can also turn the timer off in the VeSync app.

Note:

- You can change the fan speed at any time while the timer is on.
- The timer will restart if the time is changed.

Display Off

This turns off the display lights on the air purifier, including button lights and indicator lights (except the Check Filter Indicator).

1. Tap  to turn off the display.
2. Tap any button to temporarily turn the display back on. If you don't tap another button, the display will turn back off after 6 seconds.
3. Tap  to turn the display back on. The display will stay on.



Note:

- The Check Filter Indicator will still turn on and stay on if it's time to check your filter (see page 14).
- With light detection on, it is unable to keep the screen lit in a dark room. If you prefer to keep the display lit up, you can turn off the light detection in VeSync APP.

USING YOUR SMART AIR PURIFIER (CONT.)

Display Lock

When the air purifier is on, you can lock the display to prevent settings from being accidentally changed. Buttons will not respond to being tapped.

1. Press and hold  for 3 seconds to lock the display. The Display Lock Indicator will light up above the  button.

Note: *If the display is turned off, the Display Lock Indicator will flash 3 times to show that the display has been locked, then turn off.*

2. The Display Lock Indicator will blink when any other button is tapped to indicate that Display Lock is on.
3. Press and hold  again for 3 seconds to unlock the display. The Display Lock Indicator will turn off.

Standby Mode

The air purifier is in Standby Mode when it is turned off, but plugged in.

Note:

- *In Standby Mode, the infrared dust sensor will still detect the surrounding air quality and give you updates in the VeSync app.*
- *Display Lock (available in the VeSync app) can be used while the air purifier is in Standby Mode to keep the air purifier from being turned back on.*

Memory Function

When the air purifier is turned off and unplugged, it will remember its previous fan speed, Sleep Mode, Auto Mode, Pet Mode, and in-app Display and Light Detection settings.

Note: *The air purifier will not remember timers.*

USING YOUR SMART AIR PURIFIER (CONT.)

VeSync App Functions

The VeSync app allows you to access additional smart air purifier functions, including those listed below. As the app develops, more features may become available.

Remote Control

- Change any air purifier settings through the app, even while Display Lock is on.

Air Quality Updates

- View real-time air quality updates in the app.
- See your air quality history for the previous 4 weeks.

Pet Mode

- Pet Mode is efficient at filtering allergens from the air while conserving energy.
- When Pet Mode is on, the air purifier runs for 15 minutes at high speed (3 indicator lights), then 60 minutes at medium speed (2 indicators), and cycles between the two fan speeds. The corresponding fan speed indicators and the  button on the air purifier's display will light up.
- When Pet Mode is on, and the light sensor detects the room is dark, the display will turn off and limit Pet Mode to medium fan speed (2 indicators), to avoid making too much noise. When the light sensor detects that the room is lit again, Pet Mode will no longer be limited, and the air purifier will run at medium fan speed (2 indicators) for 30 minutes, then run at high (3 indicators) for 15 minutes. After this, the normal Pet Mode cycle will start (15 minutes at high speed, then 60 minutes at medium speed).
- To turn off Pet Mode, tap Auto Mode, Sleep Mode, or select a fan speed on the air purifier's display or in the VeSync app.

Note:

- The corresponding fan speed indicators will light up depending on which fan speed is currently running.
- Pet Mode will stay on unless you select a different mode or fan speed.

USING YOUR SMART AIR PURIFIER (CONT.)

Auto Mode

- Access additional auto modes: Quiet Auto Mode and Efficient Auto Mode.
 - Quiet Auto Mode uses the medium fan speed (2 indicator lights) instead of the high or turbo fan speeds, even when the air quality is poor, to avoid making too much noise.
 - Efficient Auto Mode lets you choose the size of the area you want to purify. The air purifier will use the turbo fan speed to clean the air for a designated amount of time. This time is based on 1 ACH and the size of the room, meaning how long it takes for the air purifier to clean all the air in your room one time, regardless of the air quality. After this, the mode will adjust the fan speed according to the actual detected air quality in the room.

Note: *Efficient Auto Mode is useful for purifying odors from the air. The air purifier's dust sensor can only detect particles in the air, not smells. Efficient Auto Mode does not rely on the dust sensor, but the room size instead.*

Display Lock

- Turn the Display Lock on/off.
- Display Lock prevents current settings from being changed on the air purifier.
-  will flash to indicate that the display is locked.

Schedules

- Create and customize schedules for your air purifier to match your routines.

Timer Function

- Set a timer between 1–24 hours.
- Easily view the exact time remaining on a timer.

Filter Replacement Info

- Keep tabs on the remaining filter life by checking the filter life percentage in the app.
- Shop for replacement filters.

ABOUT THE FILTER

The air purifier uses a 3-stage filtration system to purify air.

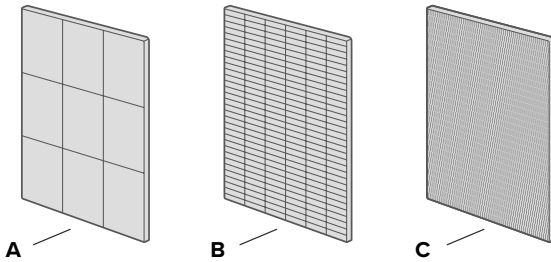

A. Washable Pre-Filter

- Captures large particles such as dust, lint, fibers, hair, and pet fur.
- Maximizes the filter's life by protecting it.
- Removable and washable to increase filtering efficiency (see **Cleaning the Pre-Filter**, page 18).

B. Main Filter

- Traps at least 99.97% of airborne particles 0.3 microns in size.
- Filters small particles such as fine dust, smoke particles, and allergens such as pollen and pet dander.

C. High-Efficiency Activated Carbon Filter

- Physically adsorbs smoke, odors, and fumes.
- Filters compounds such as formaldehyde, benzene, ammonia, hydrogen sulfide, and volatile organic compounds (VOCs).

ABOUT THE FILTER (CONT.)

Humidity

Moisture may damage the filter. This air purifier should be used in an area with a humidity level 85% RH or below. If you use the air purifier in excessively humid areas, the surface of the filter may become moldy.

***Note:** Water or moisture will allow mold to grow. To solve a mold problem, get rid of the source of the moisture and clean up the mold.*

Essential Oils

Do not add essential oils to the air purifier or filter. The filter will become damaged by the oil and will eventually release an unpleasant smell.



Do not use diffusers near the air purifier.

CARE & MAINTENANCE

Cleaning the Smart Air Purifier

- Unplug before cleaning.
- Wipe the outside of the air purifier with a soft, dry cloth. If necessary, wipe the housing with a damp cloth, then immediately dry.
- Vacuum the inside of the air purifier.
- **Do not** clean with abrasive chemicals or flammable cleaning agents.

Check Filter Indicator





 will light up as a reminder to check the filter. Depending on how often you use the air purifier, the indicator should turn on after about 12 months. You may not need to change your filter yet, but you should check it when  lights up.

When your air purifier is set up with the VeSync app, you can also check the app to see the remaining filter life. You will also receive a notification from VeSync when it's time to check your filter.

Note: *The VeSync app uses a scientific algorithm to determine your filter life based on air quality, amount of use, and other factors. The filter life percentage is based on 12 hours of daily use.*

Resetting the Check Filter Indicator

Reset the Check Filter Indicator when:

-  lights up. This is the Check Filter Indicator light.
 - Replace the filter (see page 19).
 - Turn on the air purifier.
 - To reset the Check Filter Indicator, press and hold  for 3 seconds.
 - The Check Filter Indicator light will flash, and turn off when successfully reset. The filter life will show as 100% in the VeSync app.
- The filter was changed before  lit up.
 - After replacing the filter, turn on the air purifier.
 - To reset the Check Filter Indicator, press and hold  for 3 seconds.
 - The Check Filter Indicator will flash, and turn off when successfully reset. The filter life will show as 100% in the VeSync app.

CARE & MAINTENANCE (CONT.)

Cleaning the Pre-Filter

The Washable Pre-Filter should be cleaned every 2–4 weeks to increase efficiency and extend the life of your filter. You can set a reminder in the VeSync app to clean the pre-filter every 2, 3, or 4 weeks. Clean the pre-filter using a soft brush or vacuum hose to remove hair, dust, and large particles. Optionally, you can wash the pre-filter with water and a mild detergent to remove dirt and dust.

Note: Avoid scrubbing, scraping, or vigorously brushing the pre-filter. **Do not** use abrasive cleaning materials.

To wash the pre-filter:

1. Turn off the air purifier.
2. Open the front cover
3. Push the pre-filter's tabs inward and pull to remove the pre-filter.
4. Clean the surface of the pre-filter with a vacuum. *[Figure 2.1]*

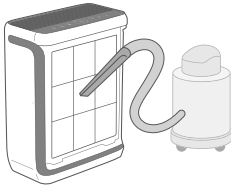

Figure 2.1

5. Rinse the pre-filter with water under a faucet.
6. Wash the pre-filter with mild detergent and a soft cloth. *[Figure 2.2]*

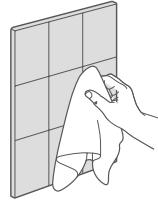

Figure 2.2

7. Allow the pre-filter to air-dry. Once completely dry, place the pre-filter back into the air purifier. *[Figure 2.3]*

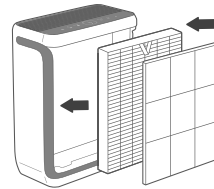

Figure 2.3

Filter	When to Clean	How to Clean	When to Replace
Washable Pre-Filter	Every 2–4 weeks	Use a soft cloth or vacuum hose	Does not need to be replaced
		Wash with water and mild detergent	
Main / Activated Carbon Filter	Do not clean		12 months

CARE & MAINTENANCE (CONT.)

When Should I Replace the Filter?

The Main / Activated Carbon Filter should be replaced every 12 months. You may need to replace your filter earlier or later depending on how often you use your air purifier. Using your air purifier in an environment with relatively high pollution may mean you will need to replace the filter more often, even if the Check Filter Indicator is off.

You may need to replace your filter if you notice:

- The air purifier does not effectively filter certain odors anymore
- Increased noise when the air purifier is on
- Decreased airflow from the top of the air purifier
- Unusual odors
- The Main filter is visibly dusty or discolored after removing the pre-filter

Note:

- *To maintain the performance of your air purifier, **only** use official Levoit filters. For more information, contact **Customer Support** (see page 27).*
- *Remember to reset the Check Filter Indicator after replacing the filter (see page 17).*

Replacing the Filter

1. Unplug the air purifier, then pull the front cover to remove it (see **Getting Started**, page 7).
2. Push the pre-filter's tabs inward and pull to remove the pre-filter.
3. Remove the old filter from the air purifier.
4. Clean out any remaining dust or hair inside the air purifier using a vacuum hose.

Note: Do not use water or liquids to clean the air purifier.

5. Remove the plastic packaging from the new filter and place the filter and pre-filter inside the air purifier (see **Getting Started**, page 7)
6. Replace the front cover.
7. Plug in and turn on the air purifier. Reset the Check Filter Indicator (see page 17).

CARE & MAINTENANCE (CONT.)

Cleaning the Dust Sensor

It is recommended to clean the AirSight™ Infrared Dust Sensor lens every 2 months to help maintain the efficiency of the sensor. If the Air Quality Indicator is red (indicating “Bad” air quality) more than usual, you may need to clean your dust sensor.

Note: How often you clean the dust sensor will depend on the air quality of your environment. If your air is often polluted with dust, dander, smoke, and other particles, you may need to clean your dust sensor more often.

1. Unplug the air purifier.
2. Open the dust sensor cover. [Figure 3.1]

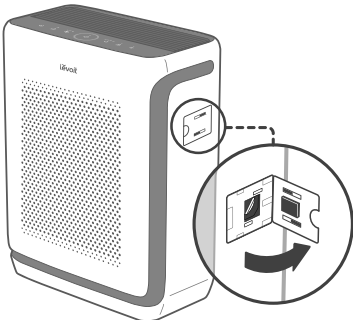

Figure 3.1

3. Use a cotton swab dipped in water to clean the dust sensor lens. [Figure 3.2]

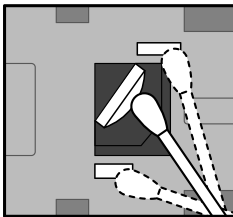

Figure 3.2

4. Wipe the lens dry with a dry cotton swab.
5. Replace the dust sensor cover.

Note: Do not remove the foam piece attached to the dust sensor cover unless instructed by Customer Support. [Figure 3.3]

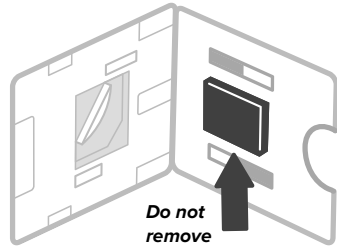



Figure 3.3







Storage

If not using the air purifier for an extended period of time, wrap both the air purifier and the filter in plastic packaging and store in a dry place to avoid moisture damage.

TROUBLESHOOTING

Problem	Possible Solution
<p>Air purifier will not turn on or respond to button controls.</p>	Plug in the air purifier.
	Check to see if the power cord is damaged. If it is, stop using the air purifier and contact Customer Support (see page 27).
	Plug the air purifier into a different outlet.
	The air purifier may be malfunctioning. Contact Customer Support (see page 27).
<p>Airflow is significantly reduced.</p>	Make sure the filter is removed from its packaging and properly in place (see page 7).
	Tap  to increase the fan speed.
	Leave 15 inches / 38 cm of clearance from the front of the air purifier.
	The pre-filter may be clogged by large particles, such as hair or lint, blocking airflow. Clean the pre-filter (see page 18).
	Replace the filter (see page 19).
<p>Air purifier makes an unusual noise while the fan is on.</p>	Make sure the filter is properly in place with plastic packaging removed (see page 7).
	Make sure the air purifier is operating on a hard, flat, level surface.
	Replace the filter (see page 19).
	The air purifier may be damaged, or a foreign object may be inside. Stop using the air purifier and contact Customer Support (see page 27). Do not try to repair the air purifier.
<p>Poor air purification quality.</p>	Tap  to increase the fan speed.
	Make sure no objects are blocking the front, sides, or top of the air purifier (the inlet or outlet).
	Make sure the filter is removed from its packaging and properly in place (see page 7).
	Close doors and windows while using the air purifier.
	If the room is larger than 380 ft ² / 35 m ² , air purification will take longer.
	Replace the filter (see page 19).

TROUBLESHOOTING (CONT.)

Problem	Possible Solution
Strange smell coming from the air purifier.	Clean the filter, or replace if necessary.
	Contact Customer Support (see page 27).
	Make sure not to use your air purifier in an area with high humidity or while diffusing essential oils.
Air Quality Indicator always stays blue, even when the air quality is poor.	Clean the dust sensor lens (see page 20).
	The dust sensor detects airborne particles, but it cannot detect gas. Make sure there aren't gasses polluting the air.
Air Quality Indicator always stays red.	Clean the dust sensor lens (see page 20).
	If you're using an ultrasonic humidifier near the air purifier, the mist may affect the accuracy of the dust sensor. The dust sensor will detect the large mist particles, and the Air Quality Indicator may turn red. Avoid using an ultrasonic humidifier near the air purifier, or avoid using Auto Mode.
Air purifier randomly turns off.	Air purifier is malfunctioning. Stop using the air purifier and contact Customer Support (see page 27).
 is still on after replacing the filter.	Reset the Check Filter Indicator (see page 17).
 has not turned on after 12 months.	 is a reminder for you to check the filter and will light up based on how much the air purifier has been used, as well as other factors (see page 17). If you don't use your air purifier often,  will take longer to turn on.
 turned on before 12 months.	 is a reminder for you to check the filter and will light up based on how much the air purifier has been used, as well as other factors (see page 17). If you run your air purifier frequently,  will turn on sooner.
The display does not stay on in darkness room.	Make sure that the Light detection is off (see page 11).
The purifier always shuts off automatically in a dark room.	Make sure that the Light detection is off (see page 11).

If your problem is not listed, please contact **Customer Support** (see page 27).

VESYNC APP TROUBLESHOOTING

My smart air purifier isn't connecting to the VeSync app.

- Make sure your phone has Bluetooth® turned on and is not currently connected to another Bluetooth device.
- During the setup process, you must be on a secure 2.4GHz Wi-Fi® network. Confirm that the network is working correctly.
- Make sure the Wi-Fi password you entered is correct.
 - There should be no spaces at the beginning or end of the password.
 - Test the password by connecting a different electronic device to the router.
 - If you're manually typing in the SSID and password, double check that both are entered correctly.
- Try moving your air purifier closer to the router. Your phone should be as close as possible to your air purifier.
- Your router may need to be at a higher location, away from obstructions.
- Make sure your air purifier and router are away from appliances (such as microwave ovens, refrigerators, electronic devices, etc.) to avoid signal interference.
- If you're using a VPN, make sure it's turned off while setting up your air purifier.
- Disable portal authentication for your Wi-Fi network. If portal authentication is enabled, the air purifier will not be able to access your Wi-Fi network, and setup will fail.

Note: *Portal authentication means that you need to sign in to your Wi-Fi network through a web page before you can use the Internet.*

My air purifier is offline.

- Make sure the air purifier is plugged in and has power, then refresh the VeSync menu by swiping down on the screen.
- Make sure your router is connected to the internet and your phone's network connection is working.
- Delete the offline air purifier from the VeSync app. Swipe left (iOS®) or press and hold (Android™), then tap **Delete**. Reconfigure the air purifier with the VeSync app.

Note: *Power outages, internet outages, or changing Wi-Fi routers may cause the air purifier to go offline.*

If your problem is not listed, please contact **Customer Support** (see page 27).

FEDERAL COMMUNICATION COMMISSION INTERFERENCE STATEMENT – PART 15

This device complies with Part 15 of the FCC Rules. Operation is subject to the following two conditions:

1. This device may not cause harmful interference, and
2. This device must accept any interference received, including interference that may cause undesired operation.

NOTE: This equipment has been tested and found to comply with the limits for a Class B digital device, pursuant to Part 15 of the FCC Rules. These limits are designed to provide reasonable protection against harmful interference in a residential installation. This equipment generates, uses and can radiate radio frequency energy and, if not installed and used in accordance with the instructions, may cause harmful interference to radio communications. However, there is no guarantee that interference will not occur in a particular installation. If this equipment does cause harmful interference to radio or television reception, which can be determined by turning the equipment off and on, the user is encouraged to try to correct the interference by one or more of the following measures:

- Reorient or relocate the receiving antenna.
- Increase the separation between the equipment and receiver.
- Connect the equipment into an outlet on a circuit different from that to which the receiver is connected.
- Consult the dealer or an experienced radio/TV technician for help.

FCC Caution: Any changes or modifications not expressly approved by the party responsible for compliance could void the user's authority to operate this equipment.

FCC RADIATION EXPOSURE STATEMENT

This equipment complies with FCC radiation exposure limits set forth for an uncontrolled environment. End users must follow the specific operating instructions for satisfying RF exposure compliance. To maintain compliance with FCC RF exposure compliance requirements, please follow operation instructions as documented in this manual. This transmitter must not be co-located or operating in conjunction with any other antenna or transmitter. This equipment should be installed and operated with a minimum distance of 20 cm between the radiator and your body. The availability of some specific channels and/or operational frequency bands are country dependent and are firmware programmed at the factory to match the intended destination. The firmware setting is not accessible by the end user.

FCC SDOC SUPPLIER'S DECLARATION OF CONFORMITY

Arovast Corporation hereby declares that this equipment is in compliance with the FCC requirements. The declaration of conformity may be consulted in the support section of our website, accessible from www.levoit.com

WARRANTY INFORMATION

Product Name	Vital 200S-P Smart Air Purifier
Model	LAP-V201S-WUS, LAP-V201S-KUS
Date of Purchase	
Order ID	

Levoit Limited Product Warranty

Register your products at <https://warranty.levoit.com/warranty> to stay up to date with important product information such as product updates, limited warranties, usage and maintenance recommendations, and notifications concerning safety warnings or product recalls. Registration is not required to claim your limited warranty.

Two (2) Year Limited Consumer Product Warranty

Arovast Corporation ("Arovast") warrants that the product shall be free from defects in material and workmanship for a period of **2 years from the date of original purchase** ("Limited Warranty Period"), provided the product was used in accordance with its use and care instructions (e.g., in the intended environment and under normal circumstances).

Your Limited Warranty Benefits

During the Limited Warranty Period and subject to this limited Warranty Policy, Arovast will, in its sole and exclusive discretion, either (i) refund the purchase price if the purchase was made directly from the online Levoit store, (ii) repair any defects in material or workmanship, (iii) replace the product with another product of equal or greater value, or (iv) provide store credit in the amount of the purchase price.

Who is Covered?

This limited warranty extends only to the original consumer purchaser of the product and is not transferable to any subsequent owner of the product, regardless of whether the product transferred ownership during the specified term of the limited warranty. The original consumer purchaser must provide verification of the defect or malfunction and proof of the date of purchase to claim the Limited Warranty Benefits.

Be Aware of Unauthorized Dealers or Sellers

This limited warranty does not extend to products purchased from unauthorized dealers or sellers. Arovast's limited warranty only extends to products purchased from authorized dealers or sellers that are subject to Arovast's quality controls and have agreed to follow its quality controls. Please be aware, products purchased from an

unauthorized website or dealer may be counterfeit, used, defective, or may not be designed for use in your country. You can protect yourself and your products by making sure you only purchase from Arovast or its authorized dealers.

If you have any questions about a specific seller, or if you think you may have purchased your product from an unauthorized seller, please contact our Customer Support Team via support@levoit.com.

What's Not Covered?

- Normal wear and tear, including parts that might wear out over time (e.g., batteries, filters, cleaning brush, essential oil pads, etc.).
- If the proof-of-purchase has been altered in any way or is made illegible.
- If the model number, serial number or production date code on the product has been altered, removed or made illegible.
- If the product has been modified from its original condition.
- If the product has not been used in accordance with directions and instructions in the user manual.
- Damages caused by connecting peripherals, additional equipment or accessories other than those recommended in the user manual.
- Damages or defects caused by accident, abuse, misuse, or improper or inadequate maintenance.
- Damages or defects caused by service or repair of the product performed by an unauthorized service provider or by anyone other than Arovast.
- Damages or defects occurring during commercial use, rental use, or any use for which the product is not intended.
- If the unit has been damaged, including but not limited to damage by animals, lightning, abnormal voltage, fire, natural disaster, transportation, dishwasher, or water (unless the user manual expressly states that the product is dishwasher-safe).
- Incidental and consequential damages.
- Damages or defects exceeding the cost of the product.

Claiming Your Limited Warranty Service in 5 Simple Steps:

1. Make sure your product is within the specified limited warranty period.
2. Make sure you have a copy of the invoice and order ID or proof-of-purchase.
3. Make sure you have your product. **DO NOT** dispose of your product before contacting us.
4. Contact our Customer Support Team via support@levoit.com
5. Once our Customer Support Team has approved your request, please return the product with a copy of the invoice and order ID.

Sole and Exclusive Remedy

THE FOREGOING LIMITED WARRANTY CONSTITUTES AROVAST CORPORATION'S EXCLUSIVE LIABILITY, AND YOUR SOLE AND EXCLUSIVE REMEDY, FOR ANY BREACH OF ANY WARRANTY OR OTHER NONCONFORMITY OF THE PRODUCT COVERED BY THIS LIMITED PRODUCT WARRANTY STATEMENT. THIS LIMITED WARRANTY IS EXCLUSIVE, AND IN LIEU OF ALL OTHER WARRANTIES. NO EMPLOYEE OF AROVAST CORPORATION OR ANY OTHER PARTY IS AUTHORIZED TO MAKE ANY WARRANTY IN ADDITION TO THE LIMITED WARRANTY IN THIS LIMITED PRODUCT WARRANTY STATEMENT.

Disclaimer of Limited Warranties

TO THE FULLEST EXTENT PROVIDED BY APPLICABLE LAW, EXCEPT AS WARRANTED IN THIS LIMITED PRODUCT WARRANTY POLICY, AROVAST CORPORATION PROVIDES THE PRODUCTS YOU PURCHASE FROM AROVAST CORPORATION "AS IS" AND AROVAST CORPORATION HEREBY DISCLAIMS ALL WARRANTIES OF ANY KIND, WHETHER EXPRESS OR IMPLIED, STATUTORY, OR OTHERWISE, INCLUDING BUT NOT LIMITED TO ANY WARRANTIES OF MERCHANTABILITY, NON-INFRINGEMENT, AND FITNESS FOR PARTICULAR PURPOSE.

Limitations of Liability

TO THE FULLEST EXTENT PROVIDED BY APPLICABLE LAW, IN NO EVENT WILL AROVAST CORPORATION, ITS AFFILIATES, OR THEIR LICENSORS, SERVICE PROVIDERS, EMPLOYEES, AGENTS, OFFICERS, OR DIRECTORS BE LIABLE FOR:

(a) DAMAGES OF ANY KIND ARISING OUT OF OR IN CONNECTION WITH PRODUCTS PURCHASED FROM AROVAST CORPORATION IN EXCESS OF THE PURCHASE PRICE PAID BY THE PURCHASER FOR SUCH PRODUCTS, OR

(b) INDIRECT, SPECIAL, INCIDENTAL, CONSEQUENTIAL, OR PUNITIVE DAMAGES EVEN IF AROVAST CORPORATION OR ONE OF ITS SUPPLIERS HAS BEEN ADVISED OF THE POSSIBILITY OR LIKELIHOOD OF SUCH DAMAGES.

AND REGARDLESS OF WHETHER CAUSED BY TORT (INCLUDING NEGLIGENCE), BREACH OF CONTRACT, OR OTHERWISE, OUR LIABILITY SHALL UNDER NO CIRCUMSTANCES EXCEED THE ACTUAL AMOUNT PAID BY YOU FOR THE DEFECTIVE PRODUCT, NOR SHALL WE UNDER ANY CIRCUMSTANCES BE LIABLE FOR ANY CONSEQUENTIAL, INCIDENTAL, SPECIAL OR PUNITIVE DAMAGES OR LOSSES, WHETHER DIRECT OR INDIRECT.

EXCEPT AS COVERED BY THIS LIMITED PRODUCT WARRANTY STATEMENT, AROVAST CORPORATION SHALL NOT BE LIABLE FOR COSTS ASSOCIATED WITH THE REPLACEMENT OR REPAIR OF PRODUCTS PURCHASED FROM IT, INCLUDING, BUT NOT LIMITED TO, LABOR, INSTALLATION, OR OTHER COSTS INCURRED BY THE USER AND, IN PARTICULAR, ANY COSTS RELATING TO THE REMOVAL OR REPLACEMENT OF ANY PRODUCT.

OTHER RIGHTS YOU MAY HAVE

SOME JURISDICTIONS DO NOT ALLOW FOR: (1) EXCLUSION OF IMPLIED WARRANTIES; (2) LIMITATION ON THE DURATION OF IMPLIED WARRANTIES; AND/OR (3) EXCLUSION OR LIMITATION OF INCIDENTAL OR CONSEQUENTIAL DAMAGES; SO THE DISCLAIMERS IN THIS POLICY MAY NOT APPLY TO YOU. IN THESE JURISDICTIONS YOU HAVE ONLY THE IMPLIED WARRANTIES THAT ARE EXPRESSLY REQUIRED TO BE PROVIDED IN ACCORDANCE WITH APPLICABLE LAW. THE LIMITATIONS OF WARRANTIES, LIABILITY, AND REMEDIES APPLY TO THE MAXIMUM EXTENT PERMITTED BY LAW.

ALTHOUGH THIS LIMITED WARRANTY GIVES YOU SPECIFIC LEGAL RIGHTS, YOU MAY HAVE OTHER RIGHTS IN YOUR JURISDICTION. THIS STATEMENT OF LIMITED WARRANTY IS SUBJECT TO APPLICABLE LAWS THAT APPLY TO YOU AND THE PRODUCT. PLEASE REVIEW THE LAWS IN YOUR JURISDICTION TO UNDERSTAND YOUR RIGHTS FULLY.

CHANGES TO THIS POLICY

We may change the terms and availability of this limited warranty at our discretion, but any changes will not be retroactive.

This warranty is made by:

AROVAST Corporation
1775 FLIGHT WAY, SUITE
150 TUSTIN, CA 92782, USA

CUSTOMER SUPPORT

If you have any questions or concerns about your new product, please contact our helpful Customer Support Team.

Distributed by AROVAST Corporation

1775 FLIGHT WAY, SUITE
150 TUSTIN, CA 92782, USA

Email: support@levoit.com

Toll-Free: 1-888-726-8520

Support Hours

Mon–Fri, 9:00 am–5:00 pm PST/PDT

*Please have your order invoice and order ID ready before contacting Customer Support.



The energy efficiency of this ENERGY STAR certified model is measured based on a ratio between the model's CADR for Smoke and the electrical energy it consumes, or CADR/Watt.

ATTRIBUTIONS

Amazon, Alexa, and all related logos are trademarks of Amazon.com, Inc. or its affiliates.

Google, Android, and Google Play are trademarks of Google LLC.

App Store® is a trademark of Apple Inc.

Wi-Fi® is a registered trademark of Wi-Fi Alliance®.

iOS is a registered trademark of Cisco Systems, Inc. and/or its affiliates in the United States and certain other countries.

The Bluetooth® word mark and logos are registered trademarks owned by Bluetooth SIG, Inc. and any use of such marks by Arovast Corporation is under license. Other trademarks and trade names are those of their respective owners.

lëvoit[®]