

# MERCURY

## 48" Induction

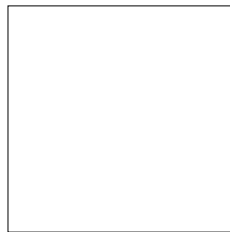

## Owner's Guide

User & Installation Instructions

**READ THESE INSTRUCTIONS FULLY BEFORE USE  
SAVE THESE INSTRUCTIONS FOR FUTURE REFERENCE**



U110648 - 03b





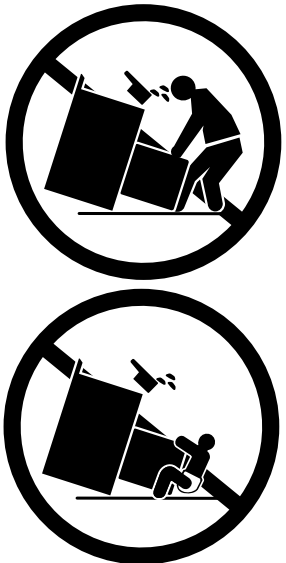

# WARNING!

The anti-tip device supplied with this range must be installed when the appliance is installed. This will reduce risk of tipping of the appliance from abnormal usage or by excessive loading of the oven door.

	<h2>▲ WARNING!</h2>
	<ul style="list-style-type: none"> <li>• <b>ALL RANGES CAN TIP.</b></li> <li>• <b>INSTALL ANTI-TIP BRACKET PACKED WITH RANGE - SEE INSTALLATION INSTRUCTIONS.</b></li> <li>• <b>A CHILD OR ADULT CAN TIP THE RANGE AND BE KILLED.</b></li> <li>• <b>ENGAGE THE RANGE TO THE ANTI-TIP DEVICE - SEE INSTALLATION INSTRUCTIONS.</b></li> <li>• <b>RE-ENGAGE THE ANTI-TIP DEVICE IF THE RANGE IS MOVED.</b></li> <li>• <b>FAILURE TO DO SO CAN RESULT IN DEATH OR SERIOUS BURNS TO CHILDREN OR ADULTS.</b></li> </ul>

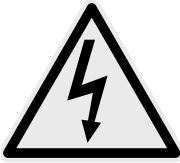
The following symbols are related to Safety and are used on the product and throughout this manual.

Meaning / Description	Symbol	Meaning / Description	Symbol
<p><b>WARNING / CAUTION</b></p> <p>An appropriate safety instruction should be followed or caution to a potential hazard exists.</p>		<p><b>HEAVY</b></p> <p>This product is heavy and reference should be made to the safety instructions for provisions of lifting and moving.</p>	
<p><b>DANGEROUS VOLTAGE</b></p> <p>To indicate hazards arising from dangerous voltages.</p>		<p><b>DISCONNECT MAINS SUPPLY</b></p> <p>Disconnect incoming supply before inspection or maintenance.</p>	
<p><b>PROTECTIVE EARTH (GROUND)</b></p> <p>To identify any terminal which is intended for connection to an external conductor for protection against electric shock in case of a fault, or the terminal of a protective earth (ground) electrode.</p>			



# Contents

<b>1. Important safety information</b>	<b>1</b>	<b>8. Installation Instructions</b>	<b>24</b>
<b>2. Range overview</b>	<b>6</b>	<b>9. Service and parts</b>	<b>25</b>
The cooktop	6	<b>10. Installation safety instructions</b>	<b>26</b>
Cooktop control indications & warnings	7	<b>11. Installation</b>	<b>27</b>
Pan detector, <i>U</i>	7	Positioning the range	28
Residual heat indicator, <i>H</i>	8	Moving the range	29
Automatic heat-up, <i>R</i>	8	<b>12. Fitting the flue, flue vent and side panels</b>	<b>30</b>
Child lock, <i>L</i>	8	Fitting the knobs	30
Low temperature/simmer setting, <i>L1/L2</i>	9	Fitting the flue	30
Power boost setting, <i>P</i>	9	Fitting the flue vent	30
Overheat function	9	Fitting the cooling fan box	31
Glide out broiler system™	10	Setting the height	31
Ovens	10	Fitting the side panel rear retaining brackets	32
Multi-function oven	10	Fitting the side panels	33
7-mode multi-function oven settings	11	Fitting the front mounting brackets	34
Convection oven	11	Fitting the bottom panel ( <i>Toe kick</i> )	35
Operating the Ovens	12	Fitting the drawer	36
Accessories	13	Fitting the anti-tip device	37
<b>3. Using the Glide-out Broiler™</b>	<b>15</b>	Completing the move	37
<b>4. Cooking tips</b>	<b>16</b>	<b>13. Removing the side panels</b>	<b>38</b>
<b>5. Cooking table</b>	<b>17</b>	Removing the storage drawer	38
<b>6. Cleaning your range</b>	<b>18</b>	Removing the bottom panel ( <i>toe kick</i> )	38
<b>7. Troubleshooting</b>	<b>22</b>	Removing the side panels	39
		<b>14. Electrical connection</b>	<b>40</b>
		<b>15. Final fitting and checks</b>	<b>42</b>
		<b>16. Circuit diagram</b>	<b>43</b>
		<b>17. Technical data</b>	<b>44</b>



# 1. Important safety information

Have your appliance properly installed and grounded by a qualified technician. The installation must conform with local codes or, in the absence of local codes, in accordance with the National Electrical Code ANSI/NFPA 70 or the Canadian Electric Code, CSA C22.1.

Install only as described in the installation section of this book.

Ask your dealer to recommend a qualified technician and an authorized repair service. Know how to disconnect the power to the range at the circuit breaker or fuse box in case of an emergency.

The anti-tip device supplied with this range must be installed when the appliance is installed. This will reduce risk of tipping of the appliance from abnormal usage or by excessive loading of the oven door or storage drawer.

Leaning, sitting or stepping on the doors or drawer of this range can result in serious injuries and also cause damage to the range. **DO NOT** allow anyone to climb, stand or hang on any part of the range.

Be sure your appliance is properly installed and grounded by a qualified technician.

## Important safety notice and warning

**⚠ IMPORTANT INFORMATION** - If you are wearing a medical device (such as a pacemaker), consult your doctor. The operation of the appliance may affect a medical device.

**⚠** Prior to connecting, the power cord should be inspected for any damage. In the event of damage please consult your electrical installer.

**⚠** You must provide adequate clearances between the range and adjacent combustible surfaces. Refer to Installation Instructions.

**⚠** Save the installation instructions for the local electrical inspector's use.

## In case of fire

**⚠ DO NOT use water on grease fires. NEVER pick up a flaming pan. Turn the controls off. Smother a flaming pan on a cooktop burner by covering the pan completely with a well fitting lid or baking tray. Isolate the power source, where it is safe to do so, either at the control or isolator. If available use a multipurpose dry chemical or foam-type fire extinguisher.**

If fire is in an oven pan, smother by closing oven door. Open doors and windows or if a hood is installed turn it on to remove smoke and odor.

## To prevent fire or smoke damage

Before using the range make sure all the packing materials have been removed.

Always keep the area around the range free from combustible materials, gasoline, and other flammable vapors and liquids.

**⚠ NEVER leave any items on the range cooktop. The hot air from an oven vent may ignite flammable items and may increase pressure in closed containers, which may cause them to burst. Many aerosol-type spray cans are EXPLOSIVE when exposed to heat and may be highly flammable. Avoid their use or storage near an appliance.**

Many plastics will burn and most are damaged by heat. Keep plastic items away from parts of the range that may become warm or hot. **DO NOT** leave plastic items on the cooktop as they may burn, melt or soften if left too close to a vent or a lighted burner.

Storage should not be installed directly above a range. If anything is stored above the range, it should be limited to infrequently used items, which can be safely stored in an area subjected to heat from a range. Temperatures may be unsafe for some items such as volatile liquids, cleaners or aerosol sprays.

Destroy the carton and plastic bags after unpacking the range. **NEVER** allow children to play with packaging material.

**⚠ NEVER use this appliance as a space heater to heat or warm the room. Doing so may result in carbon monoxide poisoning and overheating of the oven.**

**⚠ NEVER cover any slots, holes or passages in the oven bottom or cover an entire rack with materials such as aluminum foil. Doing so blocks airflow through the oven and may cause carbon monoxide poisoning. Aluminum foil linings may also trap heat, causing a fire hazard.**

**⚠ It is recommended that this appliance is serviced annually by a qualified service engineer.**

**⚠ DO NOT repair or replace any part of the appliance unless specifically recommended in this User Manual. Always consult a qualified service engineer.**

All other servicing should be done only by a qualified technician, this may reduce the risk of personal injury and damage to the range.

**NEVER** modify or alter the construction of a range by removing levelling legs, panels, wire covers, anti-tip brackets/screws, or any other part of the product.

**⚠ DO NOT leave children alone.**

Babies, toddlers and young children should not be allowed near the range at any time. They should **NEVER** be allowed to sit or stand on any part of the appliance.

**DO NOT** allow children to climb or play around the range. The weight of a child on an open door may cause the range to tip, resulting in serious burns or other injury. Teach them not to play with controls or any other part of the range.

**NEVER** store items of interest to children in the cabinets above a range or on the backguard of a range; children climbing on the range to reach them could be seriously injured.

**⚠ DO NOT use the oven for storage.**

This instruction is based on safety considerations.

Flammable materials should not be stored in an oven, the range storage drawer or near the cooktop burners. This includes paper, plastic and cloth items, such as cookbooks, plasticware and towels, as well as flammable liquids. **DO NOT** store explosives, such as aerosol cans, on or near the appliance.

Flammable materials may explode and result in fire or property damage.

**⚠ To avoid risk of electrical shock, personal injury, or death, make sure your range has been properly grounded and always disconnect it from main power supply before servicing.**

**DO NOT** touch the cooktop cooking areas.

The marked cooking areas on the cooktop may be hot even if they have been off for some time. Areas near the cooking area may become hot enough to cause burns. During and after use, **DO NOT** touch, or let clothing touch or other flammable materials contact the cooktop or areas near the cooking area until they have had enough time to cool. These areas include the rangetop and rear vent.

**⚠ DO NOT touch heating elements or interior surfaces of ovens.**

Oven heating elements may be hot though they are dark in color. Interior surfaces of an oven may become hot enough to cause burns. During and after use, **DO NOT** touch, or let clothing or other flammable materials touch heating elements or interior surfaces of oven until they have had enough time to cool.

Other range surfaces that may become hot enough to cause burns are the broiler compartment and oven vent at the rear of the range.

## **Wear suitable clothing**

**NEVER** wear loose-fitting or hanging clothes while using the range. Be careful when reaching for items stored in cabinets over the cooktop. Flammable material could be ignited if brought into contact with a hot surface and may cause severe burns.

## **Use only dry potholders or oven gloves**

Moist or damp potholders on hot surfaces may result in burns from steam. **NEVER** let a potholder touch hot heating elements.

**DO NOT** use a towel or other bulky cloth in place of a glove. They might catch fire if they touch a hot surface.

Use dry oven gloves when applicable – using damp gloves might result in steam burns when you touch a hot surface.

**NEVER** operate the range with wet hands.

## Oven care

- ⚠ **Use care when opening the door. Let hot air and steam escape before removing or replacing food (Fig. 1.1).**
- ⚠ **NEVER heat unopened food containers. Pressure build up may make container burst and cause injury.**
- ⚠ **Keep oven vent ducts unobstructed.**
- ⚠ **ALWAYS place oven racks in their desired location while the oven is cool. If a rack must be moved while the oven is hot, DO NOT let the potholders contact the heating element in the oven.**

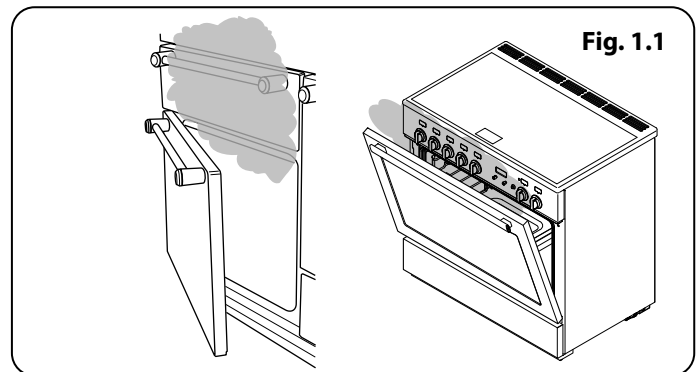

## Induction care

Important information for pacemaker and implanted insulin pump users: The functions of this cooktop comply with the applicable standards on electromagnetic interference. If you are fitted with a pacemaker or implanted insulin pump and are concerned please consult your doctor for medical advice.

To fully utilize the power of your induction stove top and to ensure longevity of performance, we recommend the use of AGA approved Induction Pots and Pans. If you decide to purchase an alternative set of pans for use on your induction range, we would strongly recommend that composite aluminum pans with steel inserts, example shown **Fig. 1.2**, are avoided. This type of pan construction can significantly reduce the lifetime and performance of your induction cook top.

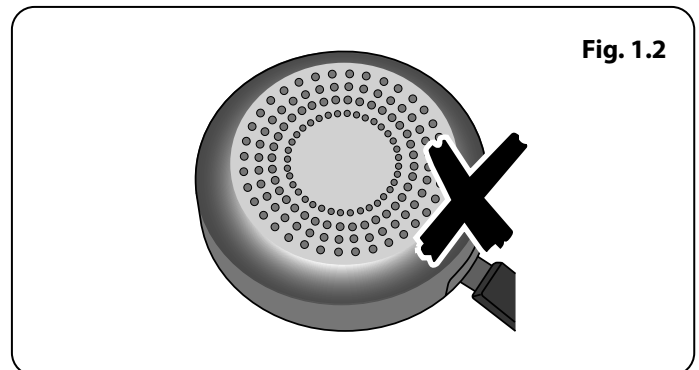

- ⚠ **Only certain types of glass, glass-ceramic, earthenware or other glazed containers are suitable for hotplate cooking; others may break because of the sudden change in temperature. NEVER cook directly on the cooktop surface (Fig. 1.3).**

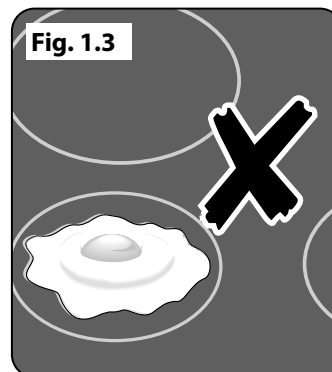

- ⚠ **DO NOT cook on a broken cooktop. If the cooktop should break, cleaning solutions and spills may penetrate the broken cooktop and cause a risk of electric shock. Contact a qualified technician immediately (Fig. 1.4).**

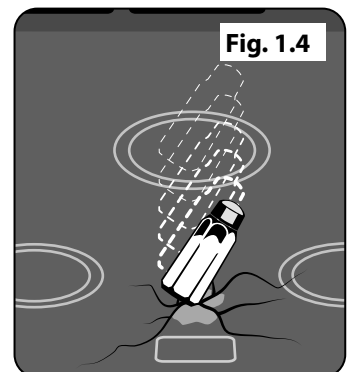

- ⚠ **Should a crack appear in the surface, disconnect the range immediately from the supply and arrange for its repair.**

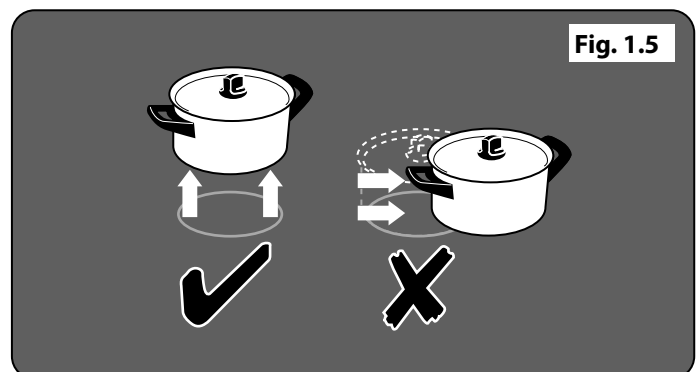

- ⚠ **NEVER leave surface units unattended at high heat settings - boilover may cause residue, that may ignite.**

- ⚠ **ALWAYS LIFT pans off the cooktop. Sliding pans may cause marks and scratches (Fig. 1.5).**

- ⚠ **Take care NOT TO PLACE HOT LIDS onto the cooktop surface (Fig. 1.6). Lids that have been used to cover a hot pan can "stick" or create a "vacuum" effect to the glass top. Should this occur, DO NOT attempt to lift the lid off the glass surface, this may damage the glass. Instead slide the lid to the edge of the cooktop and remove, taking care not to scratch the cooktop surface. Alternatively wait until the lid has cooled to room temperature, the vacuum has been released, then remove the lid by lifting it from the cooktop.**

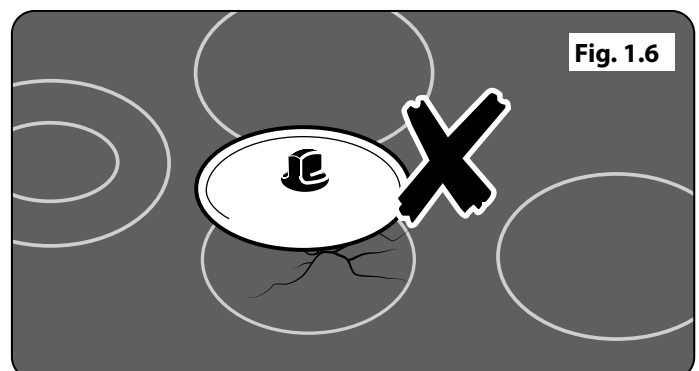

## Use the right size pan

This appliance is equipped with cooktop zones of different sizes. Use utensils with flat bottoms. **DO NOT** use unstable pans and position the handles away from the edge of the cooktop.

Proper relationship of utensil to burner will improve efficiency.

- ⚠ NEVER leave cooktop zones unattended at high settings. Pans boiling over can cause smoking and greasy spills may catch on fire.**
- ⚠ Protective Liners – DO NOT use aluminium foil to line cooktop bowls or oven bottoms. Foil liners may result in a risk of electric shock, or fire and will damage the enamel finish. NEVER allow aluminium foil to contact the heating elements.**
- ⚠ DO NOT use hotplate protectors, foil or hotplate covers of any description. These may affect the safe use of your hotplate burners and are potentially hazardous to health.**
- ⚠ Only certain types stainless steel, enamelled steel pans or cast iron pans with enamelled bases are suitable for induction cooktop cooking.**
- ⚠ Utensil handles should be turned inward and not over adjacent cooktop zones. If handles are left over adjacent zones they will get hot and may burn.**

## General safety instructions

- ⚠ This appliance is provided with rollers to facilitate movement during installation. The range should not be moved after installation.**

This appliance must be installed by a competent person in accordance with the installation instructions. The installation must comply with the relevant regulations and also the local electricity supply company requirements.

This appliance is designed for domestic cooking only. Use for any other purpose could invalidate any warranty or liability claim.

The range should be serviced by a qualified service engineer and only approved parts used. Have the installer show you the location of the range circuit breaker. Mark it for easy reference. Always allow the range to cool and then switch off at the circuit breaker before cleaning or carrying out any maintenance work, unless specified otherwise in this guide.

- ⚠ All parts of the range become hot with use and will retain heat even after you have stopped cooking.**
- ⚠ Take care when touching range, to minimize the possibility of burns, always be certain that the controls are in the OFF position and that it is cool before attempting to clean the range.**
- ⚠ Clean with caution. If a wet sponge or cloth is used to wipe spills on a hot surface, be careful to avoid steam burns. Some cleaners can produce noxious fumes if applied to a hot surface.**

Clean only parts listed in this guide.

In the interests of hygiene and safety the range should be kept clean at all times as a build up in fats and other food stuff could result in a fire.

Always keep combustible wall coverings or curtains etc. a safe distance away from your range.

- ⚠ DO NOT spray aerosols in the vicinity of the range while it is in use.**

**DO NOT** store or use combustible materials, or flammable liquids in the vicinity of this appliance.

Take great care when heating fats and oils, as they will ignite if they get too hot.

Use a deep fat thermometer whenever possible to prevent overheating fat beyond the smoking point.

 **NEVER** leave a deep fry pan unattended. Always heat fat slowly, and watch as it heats. Deep fry pans should be only a maximum of one third full of fat. Filling the pan too full of fat can cause spill over when food is added. If you use a combination of oils or fats in frying, stir them together before heating, or as the fats melt.

Foods for frying should be as dry as possible. Frost on frozen foods or moisture on fresh foods can cause hot fat to bubble up and over the sides of the pan. Carefully watch for spills or overheating of foods when frying at high or medium high temperatures. **NEVER** try to move a pan of hot fat, especially a deep fry pan. Wait until the fat is cool.

When an oven is on, **DO NOT** use the top of the flue (the round holes along the back of the range) for warming plates, dishes, drying dish towels or softening butter.

When using an electrical appliance near the cooktop, be sure that the cord of the appliance does not come into contact with the cooktop.

Take care that no water seeps into the appliance.

Make sure that your kitchen is well ventilated at all times. Use extractor fans or hoods when installed.

The range is designed for cooking foods only and must not be used for any other purpose.

The oven should **NOT** be used for heating the kitchen, not only does this waste fuel but the control knobs may become overheated.

When the oven is on **DO NOT** leave the oven door open for longer than necessary.

The specification of this range should not be altered.

 **This appliance is heavy, take care when moving it.**

When the range is not in use ensure that the control knobs are in the off position.

## 2. Range overview

Fig. 2.1

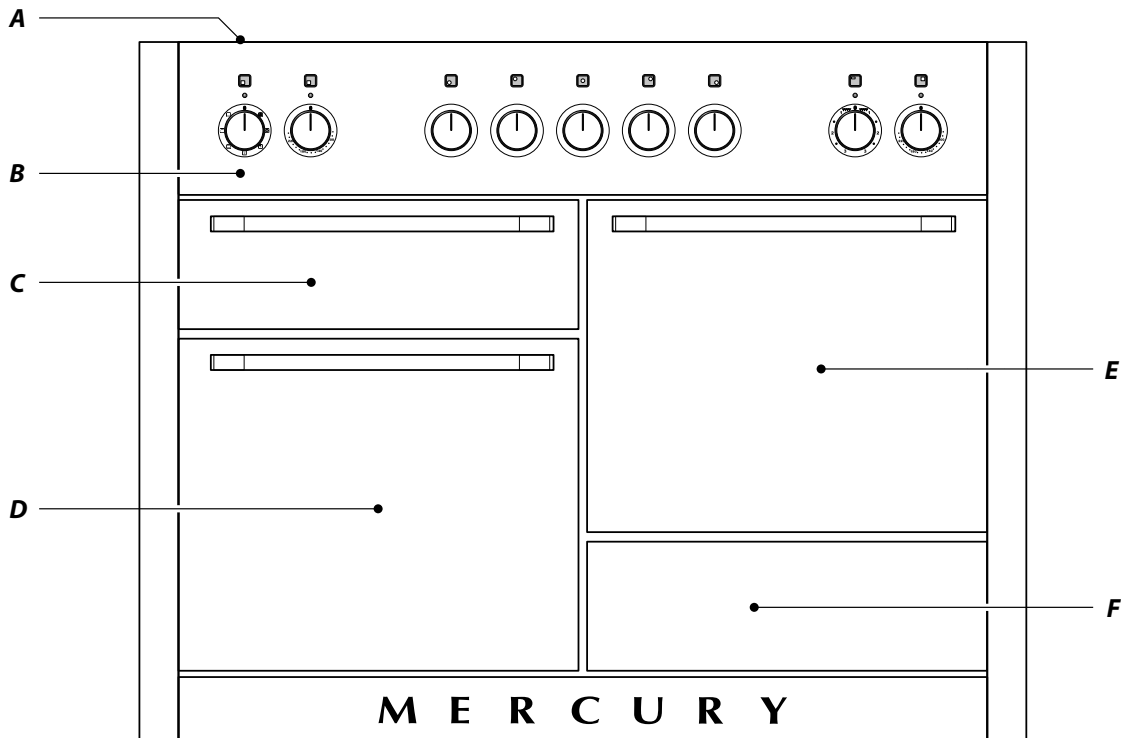
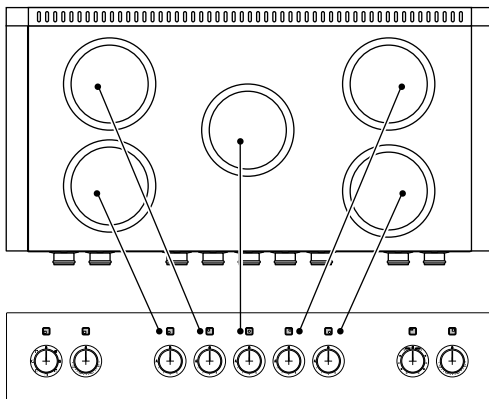

Fig. 2.2



The 48" induction range (**Fig. 2.1**) has the following features:

- A. 5 induction cooking zones
- B. A control panel
- C. A glide-out broiler system
- D. Main multi-function oven
- E. Convection oven
- F. Storage drawer

### The cooktop

Use only pans that are suitable for induction cooktops. We recommend stainless steel, enamelled steel pans or cast iron pans with enamelled bases. Note that some stainless steel pans are not suitable for use with an induction cooktop so please check carefully before purchasing any cookware.

The controls for the induction hobs are shown in **Fig. 2.2**.

Pans made of copper, aluminium or ceramic are not suitable for use on an induction cooktop. The kind of pan you use and the quantity of food affects the setting required. Higher settings are required for larger quantities of food.

Pots and pans should have thick, smooth, flat bottoms (**Fig. 2.3**). This allows the maximum heat transfer from the cooktop to the pan, making cooking quick and energy efficient. Never use a round-bottomed wok, even with a stand.

Fig. 2.3

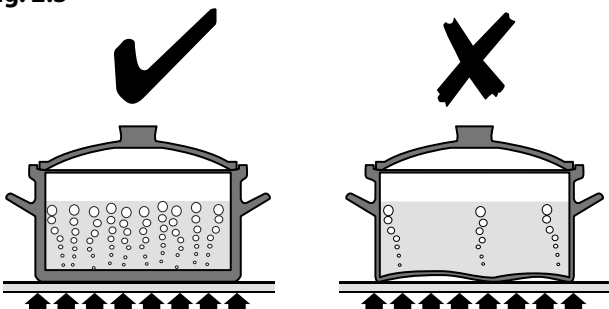

The very best pans have bases that are very slightly curved up when cold (**Fig. 2.4**). If you hold a ruler across the bottom you will see a small gap in the middle. When they heat up the metal expands and lies flat on the cooking surface.

Make sure that the base of the pan is clean and dry to prevent any residue burning onto the cooktop panel. This also helps prevent scratches and deposits.

Always use pans that are the same size as (or slightly larger than) the areas marked on the cooktop. Using a lid will help the contents boil more quickly.

**⚠ Always take care before touching the surface, even when the cooktop is turned off. It may be hotter than you think!**

## Cooktop control indications & warnings

The induction cooktop comprises of five cooking zones containing induction elements with different ratings and diameters (**Fig. 2.5**) each with a pan detector and residual heat indicator, and a cooktop control display.

The cooktop control display (**Fig. 2.6**) informs you of the following induction cooktop functions:

- $\cup$  Pan Detector
- $\#$  Residual Heat Indicator
- $\#$  Automatic Heat-up
- $\mathcal{L}$  Child Lock
- $L1/L2$  Low Temperature/Simmer Setting
- $P$  Power Boost Setting
- $\cup\#$  Advises user one or more zones are active

## Pan detector, $\cup$

**⚠ IMPORTANT: After use, switch off the cooktop element by its control and DO NOT RELY on the pan detector.**

If a cooking area is switched on and there is no pan in place or if the pan is too small for the cooking area, then no heat will be generated. The symbol [ $\cup$ ] will appear on the cooktop control display; this is the “pan-missing symbol”. Place a pan of the correct size on the cooking area and the [ $\cup$ ] will disappear and cooking can begin. After 10 minutes without detecting a pan the cooking zone will switch off automatically.

**Table 2.1** shows the minimum pan sizes recommended for each cooking zone.

**NOTE:** Using pans with a base diameter smaller than those recommended will result in a power reduction.

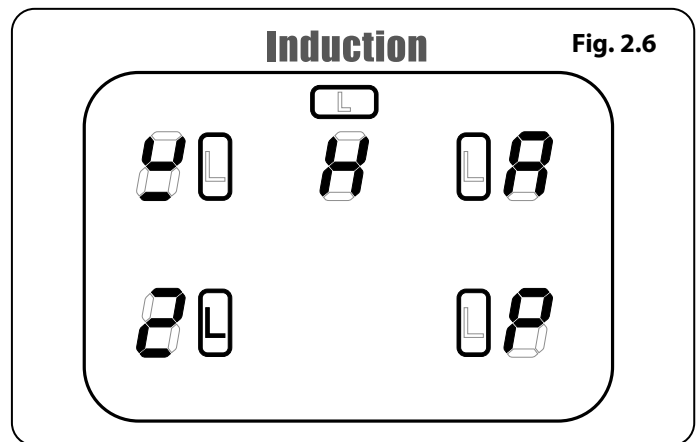
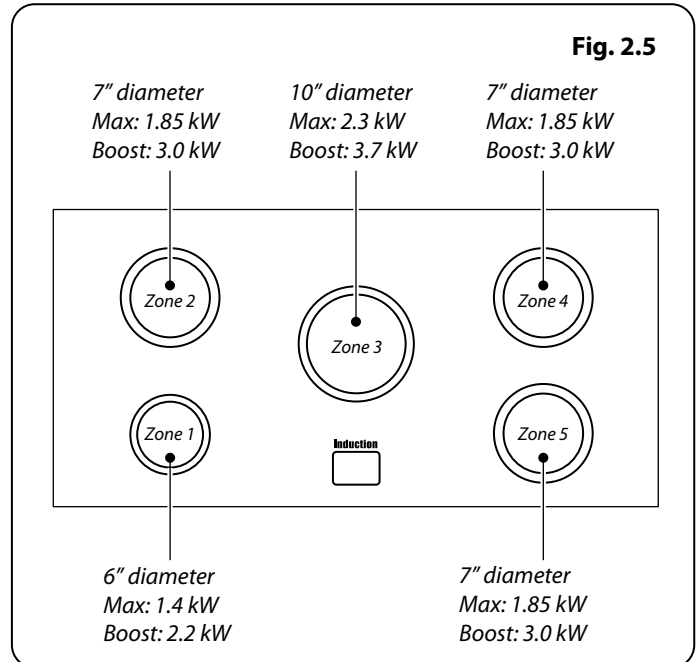
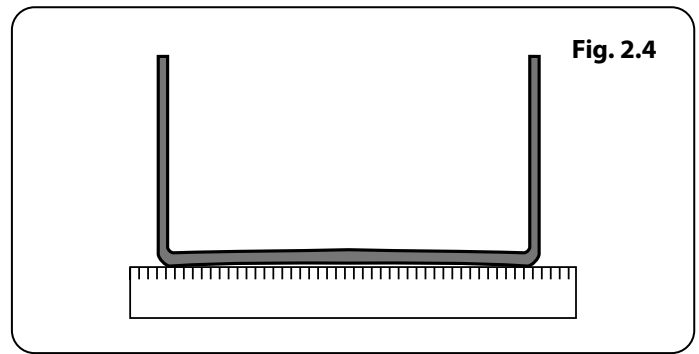

Cooking zone	Minimum Pan Diameter (Pan base) inches (mm)
Front left	4 $\frac{3}{4}$ " (120)
Rear left	5 $\frac{1}{2}$ " (140)
Centre	8 $\frac{1}{4}$ " (160)
Rear right	5 $\frac{1}{2}$ " (140)
Front right	5 $\frac{1}{2}$ " (140)

**Table 2.1**

Power level	Automatic Heat-up Time at 100% (min:sec)
1	0:48
2	2:24
3	3:50
4	5:12
5	6:48
6	2:00
7	2:48
8	3:36

**Table 2.2**

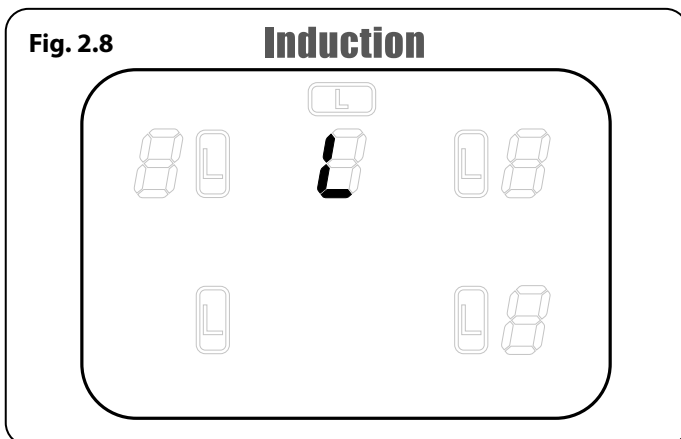
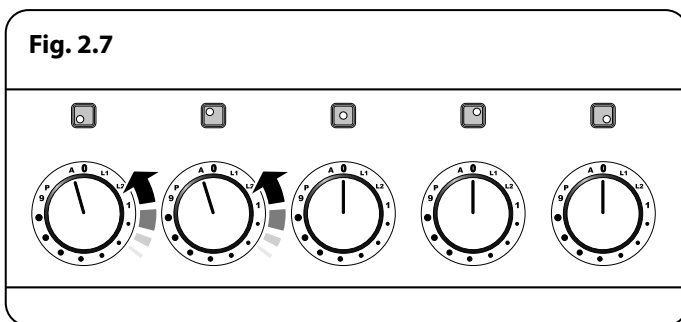

## Residual heat indicator, *H*

After use, a cooking zone will remain hot for a while as heat dissipates. When a cooking zone is switched off the residual heat indicator symbol [*H*], will appear in the display. This shows that the cooking zone temperature is above 140°F (60°C) and may still cause burns. Once the temperature has dropped to below 140°F (60°C) the [*H*] will go out.

## Automatic heat-up, *A*

This function is available on all of the cooking zones. It allows rapid heating to bring the selected cooking zone up to temperature. The zone will maintain 100% power (level 9) for the specified time and then automatically reduce power to the preset level. The function is selected by turning the control knob to the 'A' position. This can be selected by turning the control knob momentarily counter-clockwise from the zero position until the symbol [*A*] is shown on the cooktop control display.

Once the [*A*] is displayed, turn the control knob to the level of your choice (1 to 9). The pan will heat up at 100% power for a specified time before the power is reduced to the level selected.

When the Automatic Heat-up function is activated, the cooktop control display will flash alternately between the [*A*] setting and the chosen power level.

Once the Automatic Heat-up time has ended the cooktop display will stop flashing and will show the chosen power level.

The Automatic Heat-up function can be stopped by either turning the control knob back to the "0" power setting or turning the control knob to the "9" power setting.

For your guidance **Table 2.2** shows the time available at 100% power depending on the power level selected in the Automatic Heat-up mode.

## Child lock, *L*

To prevent the unwanted use by children, the cooktop can be locked.

**▲ IMPORTANT: This can only be activated when all the cooking zones are switched off.**

To lock the cooktop, simultaneously turn the two left-hand burner controls counter-clockwise (**Fig. 2.7**) and hold until the *L* symbol appears in the centre of the cooktop control display (**Fig. 2.8**).

**NOTE:** [*A*] will flash when locking the cooktop – this is normal.

Locking the cooktop will **NOT** affect the oven; it can still be used.

To unlock the cooktop, simultaneously turn the two left-hand controls counter-clockwise and hold until the *L* symbol disappears from the centre of the cooktop control display.

## Low temperature/simmer setting, L1/L2

**⚠ This function should only be used when heating from cold.**

Each cooking area is equipped with 2 low temperature settings:

- L1 will maintain a temperature of about 104°F (40°C) – ideal for gently melting butter or chocolate.
- L2 will maintain a temperature of about 194°F (90°C) – ideal for simmering (bring the pan to the boil and then select L2 to keep soups, sauces, stews, etc at an optimal simmer).

The maximum time this setting can be used is 2 hours, after which the cooktop will switch off automatically. If required, you can immediately restart the Low Temperature function by reactivating L1 or L2. To increase the heat, just turn the control knob to the required level.

The maximum times for all other power levels are shown in **Table 2.3**.

## Power boost setting, P

All of the induction cooking zones have Power Boost available, activated by turning the control knob clockwise until [P] is shown on the cooktop control display.

Power Boost allows additional power to be made available for each of the cooking zones. This is useful to bring a large pan of water to the boil quickly.

The Power Boost function operates for a maximum of 10 minutes on each zone, after which the power is automatically reduced to setting 9.

When using the Power Boost function, the cooking zones are linked.

**Fig. 2.9** shows the cooktop layout. Zones A and B are linked together as are zones D and E.

This means that when using zone A on Power Boost and then switching zone B to Power Boost, the power to zone A will reduce slightly. The last zone switched to Power Boost always takes priority. Zones D and E work in the same way. Zone C is not shared.

**⚠ This is a built in safety device.**

Deactivate the Power Boost function by turning the control knob to a lower setting.

## Overheat function

This function identifies when the temperature of the pan rises rapidly and works to maintain a safe level of pan temperature. It should not interfere with normal cooking.

Cookware with bases that become distorted (**Fig. 2.3**) when heated may interfere with the operation of the Overheat Function. This may result in damage to your cookware or Induction Glass Cooktop.

Power Level	Maximum Operating Time
L1 and L2	2 hours
1	6 hours
2	6 hours
3	5 hours
4	5 hours
5	4 hours
6	1.5 hours
7	1.5 hours
8	1.5 hours
9	1.5 hours
Power Boost	10 minutes

**Table 2.3**

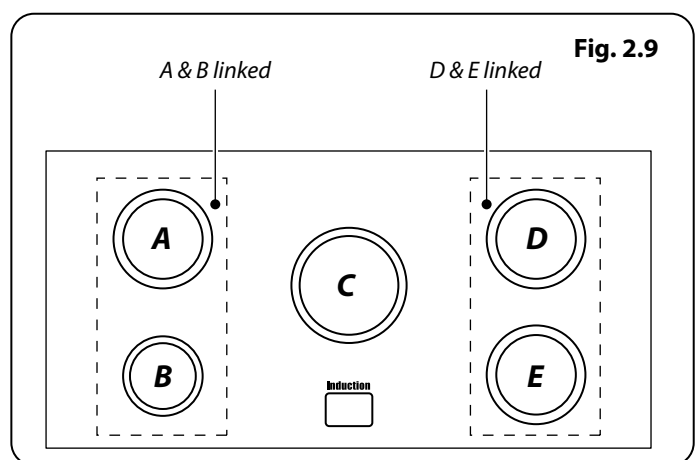

**⚠ Please remember not to leave the cooktop unattended. Care should be taken to not allow your cookware to boil dry. Damage to your cookware and Induction Glass Cooktop may result.**

Please read and follow the manufacturers' instructions carefully before using cookware on your induction cooktop.

## **Glide out broiler system™**

**⚠ When the trivet has been removed from the broiler pan, please ensure that the broiler pan and cradle are fully returned into the broiler chamber. The broiler door MUST remain open.**

1. For best results, slide the carriage back into the broiler chamber and preheat the appropriate part(s) of the broiler for two minutes. The broiler trivet can be removed and the food placed on it while you are waiting for the broiler to preheat.
2. **DO NOT** leave the broiler oven door open for more than a few moments, otherwise the knobs may become hot.
3. Preheat the broiler chamber prior to placing the food on the trivet. Once the trivet is placed back into the broiler pan, place the broiler pan back into the broiler carriage. Slide the carriage back into the broiler chamber.

**⚠ Accessible parts may be hot when the broiler is in use. Young children should be kept away.**

## **Ovens**

Please refer to **Fig. 2.1**.

References to 'left-hand' and 'right-hand' ovens apply as viewed from the front of the appliance.

The left-hand oven is a multi-function oven, while the right-hand oven is a convection oven.

## **Multi-function oven**

As well as the oven fan and fan element, they are fitted with two extra heating elements, one visible in the top of the oven and the second under the oven base. Take care to avoid touching the top element and element deflector when placing or removing items from the ovens.

The multi-function oven has 3 main cooking functions: convection, fan assisted and conventional cooking. These functions should be used to complete most of your cooking.

The browning element and base heat can be used in the latter part of the cooking process to fine tune the results to your particular requirements.

Use convection broiling for all your broiling needs and defrost to safely thaw small items of frozen food.

**Table 2.4** gives a summary of the multi-function modes.

The multi-function ovens have many varied uses. We suggest you keep a careful eye on your cooking until you are familiar with each function. Remember – not all functions will be suitable for all food types.

Please remember that all ranges vary – temperatures in your new ovens may differ to those in your previous range.

## 7-mode multi-function oven settings

### Defrost



This function operates the fan to circulate cold air only. Make sure the temperature control is OFF and that no heat is applied. This enables small items such as desserts, cream cakes and pieces of meat, fish and poultry to be defrosted.

Defrosting in this way speeds up the process and protects the food. Pieces of meat, fish and poultry should be placed on a rack, over a tray to catch any drips. Be sure to wash the rack and tray after defrosting.

Defrost with the oven door closed.

Large items, such as whole chickens and joints should not be defrosted in this way. We recommend this be carried out in a refrigerator.

Defrosting should not be carried out in a warm oven or when an adjoining oven is in use or still warm.

Make sure that dairy foods, meat and poultry are completely defrosted before cooking.

### Convection



This function operates the fan and the heating element around it. An even heat is produced throughout the oven, allowing you to cook large amounts quickly.

Convection cooking is particularly suitable for batch baking on several shelves at one time and is a good 'all-round' function. It may be necessary to reduce the temperature by approximately 25 °F/10°C for recipes previously cooked in a conventional oven.

### Convection broiling



This function operates the fan whilst the top element is on. It produces a more even, less fierce heat than convection broiling. For best results, place the food to be broiled, on a grid over a roasting tin, which should be smaller than a convection broiling pan. This allows greater air circulation. Thick pieces of meat or fish are ideal for convection broiling, as the circulated air reduces the fierceness of the heat from the broiler chamber.

The oven door should be kept closed while convection broiling is in progress, saving energy.

You will also find that the food needs to be watched and turned less. Preheat this function before cooking.

For best results we recommend that the broiling pan is not located on the uppermost shelf.

### Fan assisted



This function operates the fan, circulating air heated by the elements at the top and the base of the oven.

The combination of fan and conventional cooking (top and base heat) makes this function ideal for cooking

large items that need thorough cooking, such as a large meat roast.

It is also possible to bake on two shelves at one time, although they will need to be swapped over during the cooking time, as the heat at the top of the oven is greater than at the base, when using this function.

This is a fast intensive form of cooking; keep an eye on the food cooking until you have become accustomed to this function.

### Conventional (Top and Base Heat)



This function combines the heat from the top and base elements. It is particularly suitable for roasting and baking pastry, cakes and biscuits.

Food cooked on the top shelf will brown and crisp faster than on the lower shelf, because the heat is greater at the top of the oven than at the base, as in 'Fan Assisted' function. Similar items being cooked will need to be swapped around for even cooking. This means that foods requiring different temperatures can be cooked together, using the cooler zone in the lower half of the oven and hotter area to the top.

The exposed top element may cook some foods too quickly, so we recommend that the food be positioned in the lower half of the oven to cook. The oven temperature may also need to be lowered.

### Browning element



This function uses the element in the top of the oven only. It is a useful function for the browning or finishing of pasta dishes, vegetables in sauce, shepherds pie and lasagne, the item to be browned being already hot before switching to the top element.

### Base heat



This function uses the base element only. It will crisp up your pizza or quiche base or finish off cooking the base of a pastry case on a lower shelf. It is also a gentle heat, good for slow cooking of casseroles in the middle of the oven or for plate warming.

The Browning and Base heat functions are useful additions to your oven, giving you flexibility to finish off items to perfection.

## Convection oven

The right-hand oven is a convection oven that circulates hot air continuously, which means faster, more even cooking.

The recommended cooking temperatures for a convection oven are generally lower than a conventional oven. It may be necessary to reduce the temperature by approximately 25 °F/10°C for recipes previously cooked in a conventional oven.

**NOTE:** Please remember that all ranges vary so temperatures in your new ovens may differ to those in your previous range.

Function	Use
Defrost	To thaw small items in the oven without heat
Convection oven	A full cooking function, even heat throughout, great for baking
Convection broiling	Broiling meat and fish with the door closed
Fan assisted	A full cooking function good for roasting and baking
Conventional oven	A full cooking function for roasting and baking in the lower half of the oven
Browning element	To brown and crisp cheese topped dishes
Base heat	To crisp up the bases of quiche, pizza or pastry

Table 2.4

## Operating the Ovens

### Operating the multi-function oven

1. The multi-function oven has two controls: a function selector and a temperature setting knob (**Fig. 2.10**).
2. Turn the function selector control to a cooking function. **Fig. 2.11** shows the control set for convectional oven cooking.
3. Turn the oven temperature knob to the temperature required (**Fig. 2.11**).

The oven heating light will glow until the oven has reached the temperature you selected. It will then cycle on and off during cooking as the oven maintains the selected temperature.

### Operating the convection oven

1. Turn the oven knob to the desired temperature (**Fig. 2.12**).
2. The oven indicator light will glow until the oven has reached the temperature selected. It will then cycle on and off during cooking (**Fig. 2.13**).

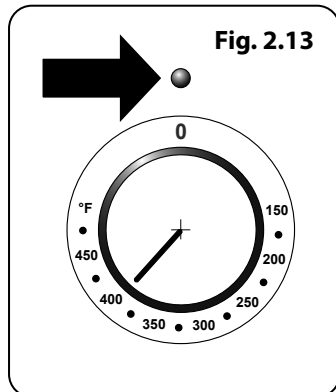
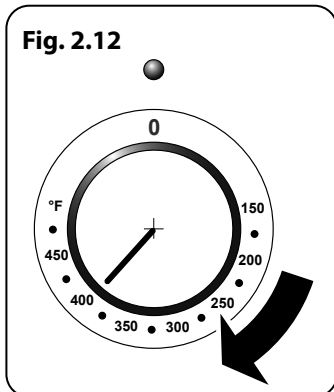
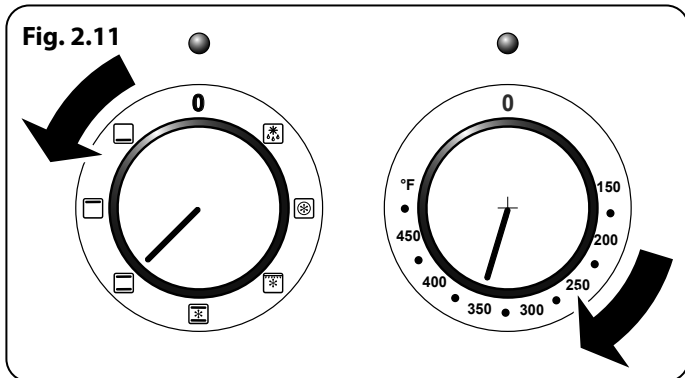
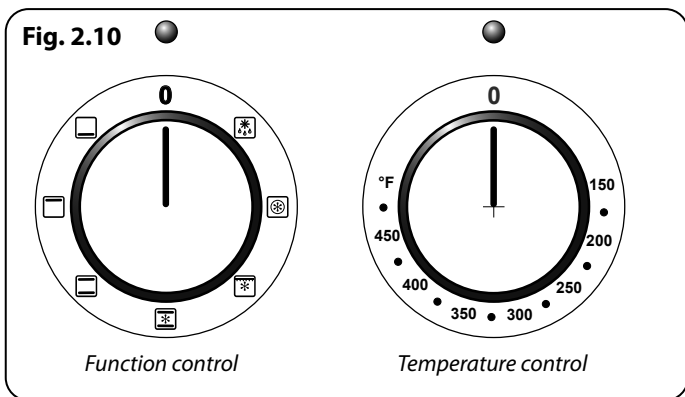

# Accessories

## Oven shelves

The range is supplied with the following:

- 2 standard shelves (**Fig. 2.14**)
- 1 drop shelf (**Fig. 2.15**)
- 2 telescopic shelf with runners (**Fig. 2.16**)
- 2 sets of side supports (**Fig. 2.17**)

The oven shelves are retained when pulled forward but can be easily removed and refitted.

### To fit the telescopic shelf runners

1. With the runner arm in the closed position locate the opening of the upper rear slot onto the side support (**Fig. 2.18**). **DO NOT** locate any further than the opening at this point.
2. Lift the front of the runner arm to locate the front slot against the side support (**Fig. 2.18**).
3. Push the runner arm towards the rear of the oven. The catch at the front will lift and drop to secure the runner arm in place (**Fig. 2.18**).

### To fit a shelf to the telescopic shelf runners

Slide the telescopic runners forward until they stop. Holding the shelf above the runners, tilt the front downward and locate into the front of the runners. Lay the shelf flat. Press on the rear of the shelf to secure in place.

### To remove a shelf from the telescopic shelf runners

1. Slide the shelf out on the runners. While holding one of the runners securely, carefully lift the rear of the shelf upwards: the shelf will spring clear of the central restraining tab. Repeat for the opposite side of the shelf.
2. **NOTE:** To aid the removal of the shelf you can insert a suitable flat tool through the opening in the side of the runners and lever the shelf clear (**Fig. 2.19**).
3. Tilt the front of the shelf downwards and then lift clear of the runners (**Fig. 2.20**).

### To remove the telescopic shelf runners

1. Firstly, remove the shelf as in the 'To Remove a Shelf from the Telescopic Shelf Runners' section.
2. Place a finger on the underside of the telescopic runner and lift.
3. Open the catch on top of the runner and pull the runner forward and down to remove.

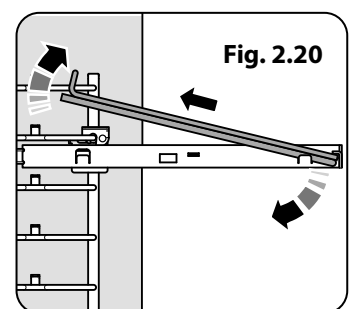
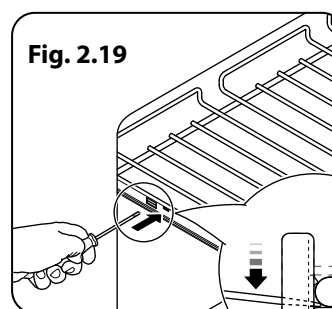
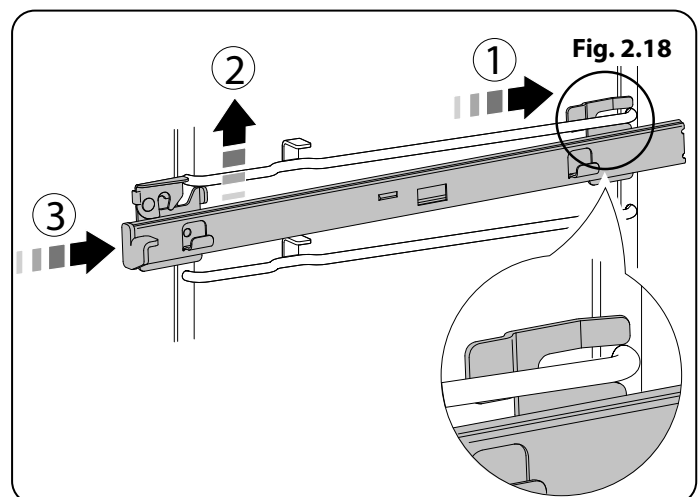
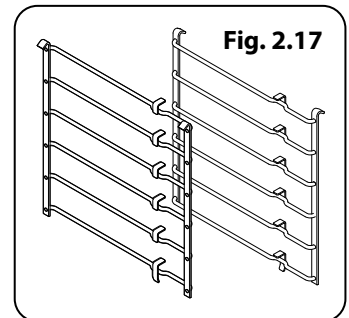
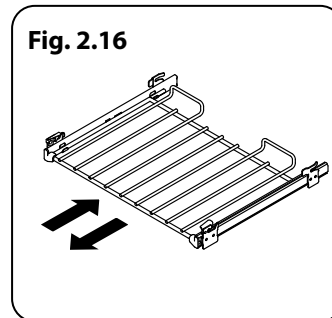
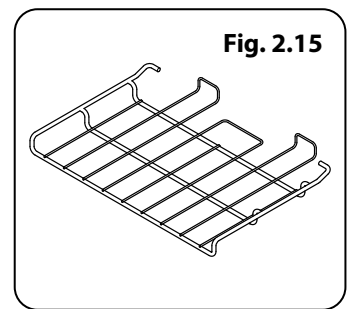
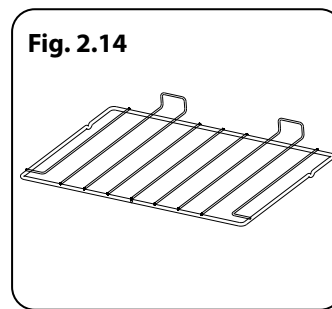

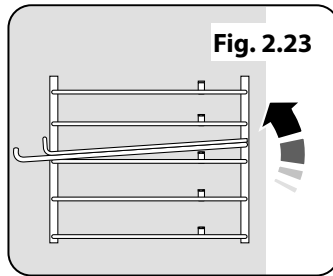
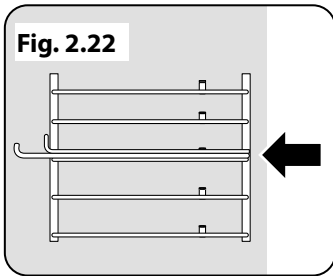
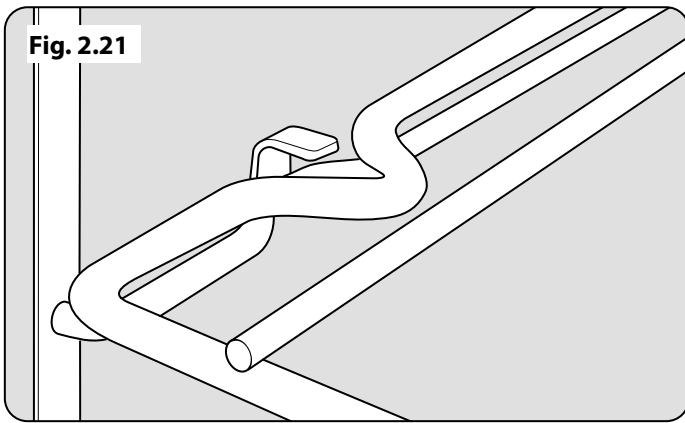

#### To remove and fit a shelf to the Side supports

1. The shelf has a small kink on either side (**Fig. 2.21**). To remove the shelf, line these up with the stops in the shelf support (**Fig. 2.22**). Lift the rear of the shelf upward so that it will pass over the shelf stop and then pull it forward (**Fig. 2.23**).
2. Fit in the reverse order, making sure to push it fully back.

#### To remove and refit the ladder shelf supports

1. Lift the ladder support hooks out of the two locating holes in the oven side (or divider) before lifting the support clear of the bottom ladder restraint.
2. Refit by inserting the bottom of the ladder into the restraint before fitting the hooks through the locating holes.

#### Storage

The bottom drawer is for storing cooking utensils.

To open, simply push the drawer in and release.

Flammable materials should not be stored in an oven, the range storage drawer or near the cooktop burners. This includes paper, plastic and cloth items, such as cookbooks, plasticware and towels, as well as flammable liquids. Do not store explosives, such as aerosol cans, on or near the appliance.

**⚠ Flammable materials may explode and result in fire or property damage.**

### 3. Using the Glide-out Broiler™

Fig. 3.1

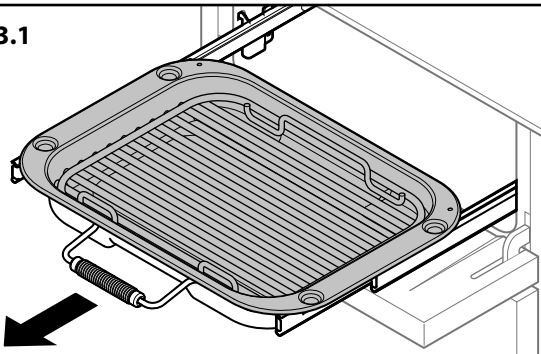
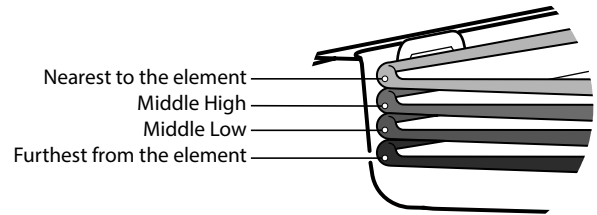
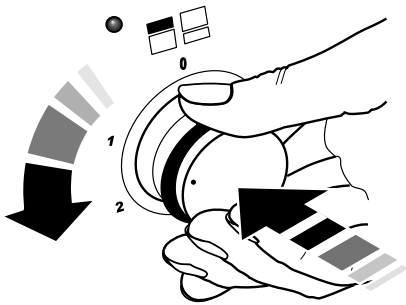

Fig. 3.2



Four grill height positions refer to Fig. 3.5

Fig. 3.3



To switch on the right half element

Fig. 3.4

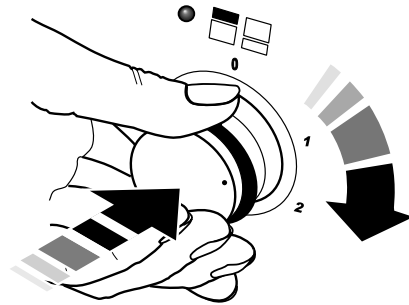

To switch on both element

Four grill height positions

Fig. 3.5

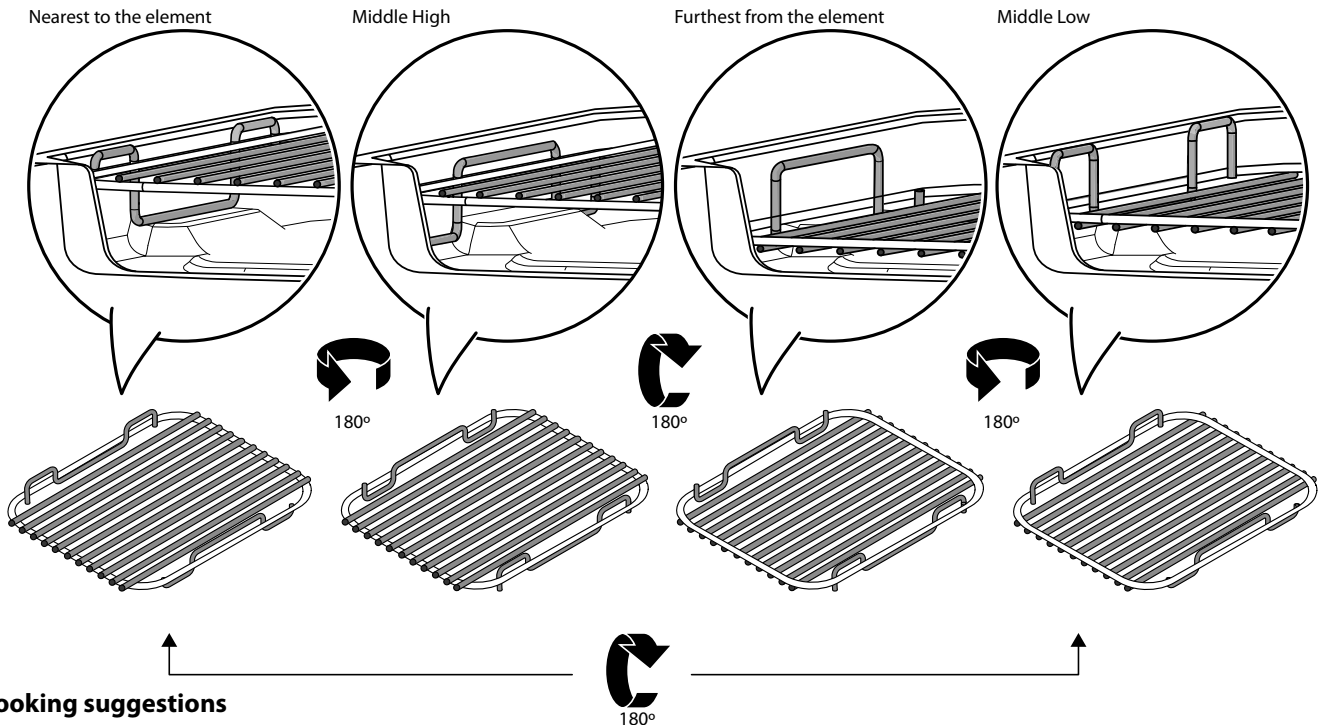

#### Cooking suggestions

1. Nearest to the element – Toast, steak.
2. Middle high – grilled cheese, sliced vegetables, Canadian peameal bacon.
3. Middle low – fish fillets, vegetable kebabs.
4. Furthest from the element – whole fish, thick pork chops, chicken breasts, chicken or beef kebabs.

**NOTE:** A short term cooking process has to be supervised continuously.

## 4. Cooking tips

### Cooking with a multi-function oven

**REMEMBER:** not all modes are suitable for all food types. The oven cooking times given are intended as a guide only.

### General oven tips

The wire racks should always be pushed firmly to the back of the oven.

Baking trays with food cooking on them should be placed level with the front edge of the oven's wire racks. Other containers should be placed centrally. Keep all trays and containers away from the back of the oven as overbrowning of the food may occur.

**When the oven is on, DO NOT leave the door open for longer than necessary, otherwise the knobs may get very hot.**

- The telescopic racks with runners can be utilized on levels 2, 3, 4 and 5. It is not possible to utilize the rack on level 1 (**Fig. 4.1**).
- Always leave a 'finger's width' between dishes on the same rack. This allows the heat to circulate freely around them.
- To reduce fat splashing when you add vegetables to hot fat around a roast, dry them thoroughly or brush lightly with cooking oil.
- Where dishes may boil and spill over during cooking, place them on a baking tray.
- If you want to brown the base of a pastry dish, preheat the baking tray for 15 minutes before placing the dish in the center of the tray.

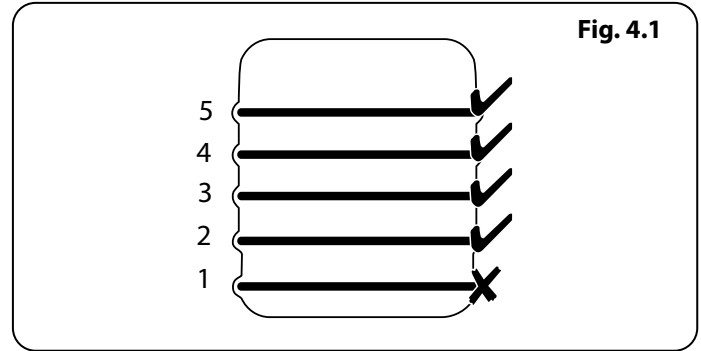
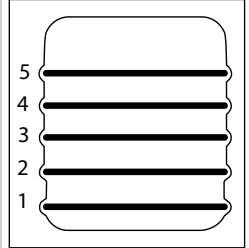



**Fig. 4.1**

## 5. Cooking table

The oven control settings and cooking times given in the table below are intended to be used as a guide only. Individual tastes may require the temperature to be altered to provide a preferred result.

Food is cooked at lower temperature in a fan oven than in a conventional oven. When using recipes, reduce the fan oven temperature by 25 °F and the cooking time by 5-10 minutes. The temperature in the fanned oven does not vary with height in the oven so you can use any shelf.



	 Conventional oven	Rack position for conventional cooking	 Convection oven	
	Temperature °F		Temperature °F	Approximate cooking time
<b>Meat</b>				
Beef (no bone)	300	2	300	30-35 minutes per 1 lb + 30-35 minutes
	375	2	375	20-25 minutes per 1 lb + 20-25 minutes
Lamb	300	2	300	30-35 minutes per 1 lb + 30-35 minutes
	375	2	375	20-25 minutes per 1 lb + 20-25 minutes
Pork & veal	300	2	300	35-40 minutes per 1 lb + 35-40 minutes
	375	2	375	25-30 minutes per 1 lb + 25-30 minutes
<b>Poultry</b>				
Chicken	300	2	300	20-25 minutes per 1 lb + 20-25 minutes
	375	2	375	15-20 minutes per 1 lb + 15-20 minutes
Turkey (slow cook)	300	2	300	25-30 minutes per 1 lb + 25-30 minutes
	375	2	375	20 minutes per 1 lb + 20 minutes
Turkey (fast cook)	300	2	300	20 minutes per 1 lb + 20 minutes
	375	2	375	15 minutes per 1 lb + 15 minutes
Duck/Duckling	300	2	300	20 minutes per 1 lb
Casserole	300	2	300	2-4 hours, according to recipe
<b>Fish</b>				
Fillet	350	2	350	15-20 minutes
Whole	350	2	350	Whole 10 minutes per 1 lb + 10 minutes
Steak out	350	2	350	Steaks according to thickness
<b>Desserts</b>				
Cup cake	325	2	325	20 minutes
Scone	375	2	375	15 minutes
Deep apple pie	350	2	350	45 minutes
Plate tart	350	2	350	45 minutes
Fruit cake 8" x 3.5"	275	2	275	1¾-2 hours
Puff pastry	400	2	400	15-40 minutes according to size
Angel food cake	325	2	325	50-60 minutes
Brownies	350	2	350	25-30 minutes
Muffins	350	2	350	25-30 minutes
Cookies	350	2	350	15-20 minutes
Pound cakes	350	2	350	40-60 minutes
Bread	375	2	375	20-30 minutes

## 6. Cleaning your range

---

### Essential information

- ⚠ Before thorough cleaning, turn off the circuit breaker. Allow the range to cool.**
- ⚠ After cleaning remember to switch on the circuit breaker before using the range.**
- ⚠ NEVER use paint solvents, caustic cleaners, biological powders, bleach, chlorine based bleach cleaners, coarse abrasives or salt.**
- ⚠ DO NOT mix different cleaning products – they may react together with hazardous results.**

Recommended cleaning materials are shown in **Table 6.1** on page 21.

### Cooktop

#### Daily care

First of all make sure that all heat indicator lights are off and that the cooking surface is cool. Clean the surface with hot soapy water or a non-abrasive cleaner if necessary. As a final step, wipe the cooking surface with a clean, dry paper towel.

#### Cleaning spills

For spills and boil-overs that occur while cooking, turn the unit off and wipe the area surrounding the hot zone with a clean paper towel. If a spill (other than a sugary substance) is on the hot zone, do not clean until the unit has completely cooled down, and then follow the instructions below ('Cleaning Burned-on Spills').

If you accidentally melt anything on the surface, or if you spill foods with a high sugar content (preserves, tomato sauce, fruit juice, etc.), remove the spill IMMEDIATELY with a razor scraper, while the unit is still hot.

- ⚠ IMPORTANT: Use an oven glove to protect your hand from potential burns.**

Scrape the major spill or melted material from the cooking zone and push into a cold area. Then, turn the unit 'OFF' and allow it to cool before cleaning further. After the cooking surface cools down and the heat indicator lights go off, follow the 'Daily Care' procedure outlined above.

#### Cleaning burned-on spills

Make sure that the heat indicator lights are off and that the cooktop is cool. Remove the excess burned-on substance with a single-edged razor scraper. Hold the scraper at an angle of about 30° to the surface and then scrape off the burned-on matter.

#### AGA care and cleaning

Supplies can be found at [www.aga-ranges.com](http://www.aga-ranges.com) and purchased by calling AGA Kitchen Concierge on (800) 525 - 5601

## Control panel and oven doors

Avoid using any abrasive cleaners including cream cleaners, on brushed stainless steel surfaces. For best results use liquid detergents.

The control panel and control knobs should only be cleaned with a soft cloth wrung out in clean hot soapy water – but take care that no surplus water seeps into the appliance. Wipe with a clean dampened cloth then polish with a dry cloth. The oven doors should only be cleaned with a soft cloth wrung out in clean hot soapy water.

## Ovens

The side panels can be removed for cleaning and for cleaning behind them.

### Removing the panels to clean the enamel interior

Some of the lining panels can be removed for cleaning.

If you wish to clean the enamel interior of the oven, you will need to remove the shelves before removing the 'Cook & Clean' panels. You do not have to remove the support brackets to remove the panels. Lift each panel upward and slide forward off the support brackets (**Fig. 6.1**).

Once the panels have been removed, the oven enamel interior can be cleaned.

Refit in the reverse order.

### Glide out broiler system™

**⚠ Before you remove any of the broiler parts for cleaning, make sure that they are cool, or use oven gloves.**

Wash the broiler pan, trivet and broiler tray in hot soapy water. Alternatively, wash the broiler pan in a dishwasher.

After broilling meats or any foods that soil, leave to soak for a few minutes in the sink immediately after use. Stubborn particles may be removed from the trivet by using a nylon brush.

1. To remove the broiler pan, pull the tray assembly forwards (**Fig. 6.2**) and then lift the broiler pan clear of the broiler tray assembly (**Fig. 6.3**).
2. For safety, push the broiler tray back into the broiler chamber.
3. If you need to remove the telescopic runners to allow cleaning of the broiler chamber, first remove the broiler tray then you can unhook them from the broiler chamber sides (**Fig. 6.4**).
4. Wipe the sides clean with a soft cloth and mild detergent.

**⚠ DO NOT put the side runners in a dishwasher.**

5. Once you have finished, hook the side rails back onto the sides of the chamber. Pull the telescopic rails out and fit the broiler tray onto them, making sure to locate the cut-outs onto the telescopic runner tabs (**Fig. 6.5**).
6. Replace the broiler pan.

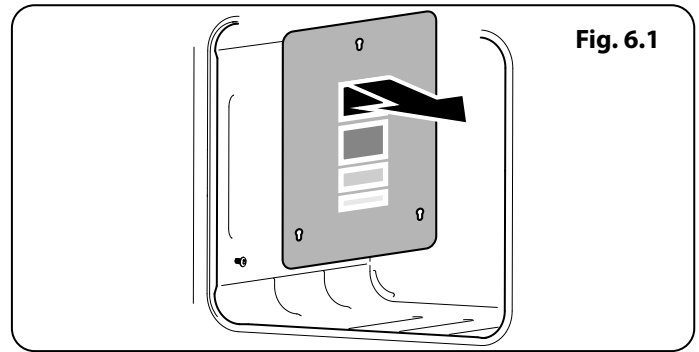

Fig. 6.1

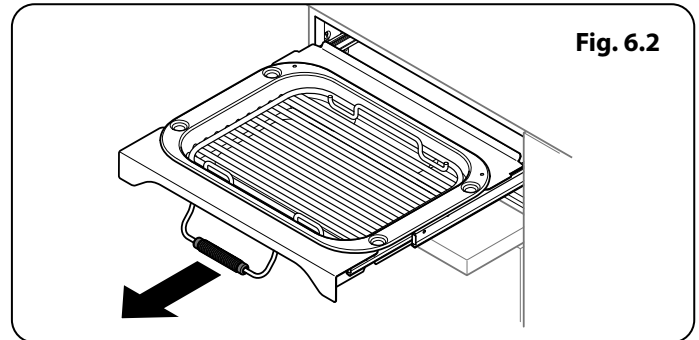

Fig. 6.2

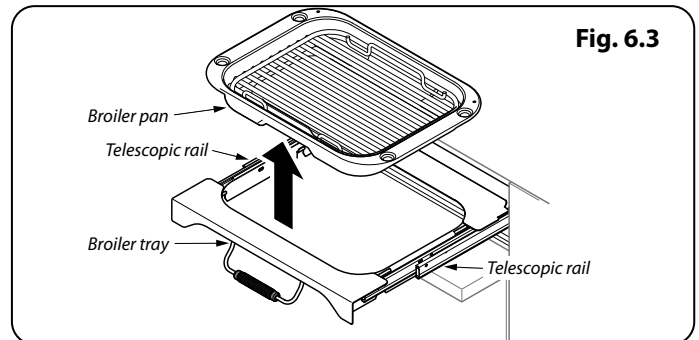

Fig. 6.3

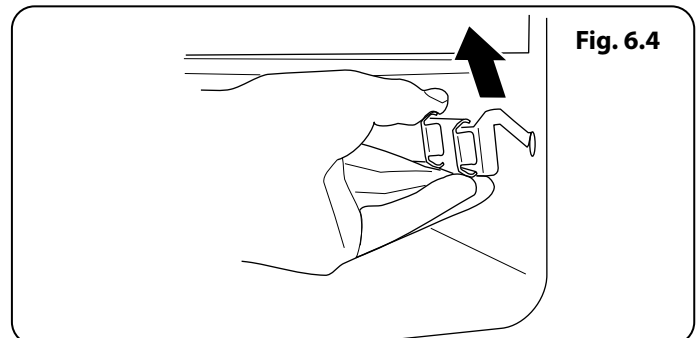

Fig. 6.4

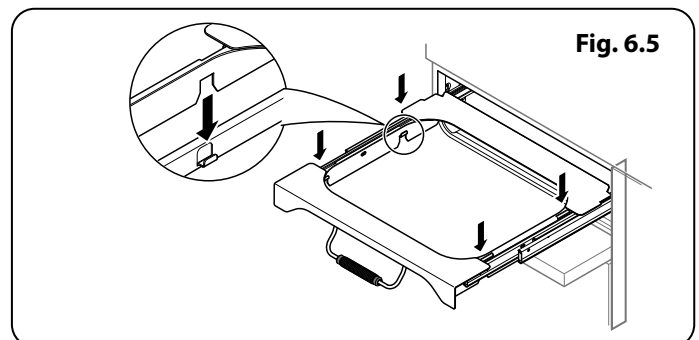
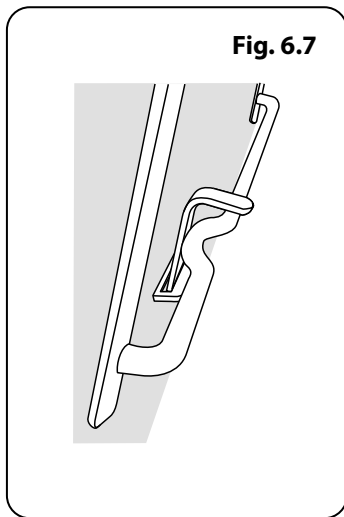
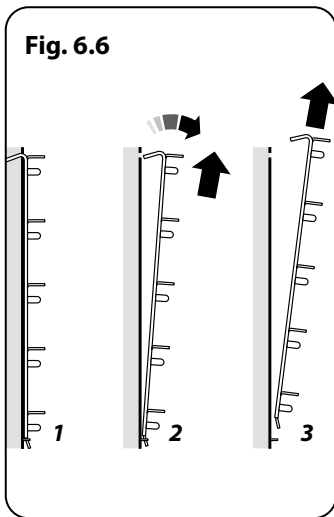

Fig. 6.5



## Oven shelf supports

The shelf supports on the oven sides can be removed for cleaning.

### Removing the oven shelf supports

Remove the oven shelves: Pull the top of the shelf support up and away from the oven side and then lift the support away from the locating bracket at the bottom of the oven side (**Fig. 6.6**).

### Refitting the oven shelf supports

To refit the side support: Locate the tag at the bottom of the support into the slot in the locating bracket in the oven side (**Fig. 6.7**). Now locate the tops of the side arms in the holes at the top and gently push down.

## Cleaning table

Cleaners listed (**Table 6.1**) are available from supermarkets or on line.

For enamelled surfaces use a cleaner that is approved for use on vitreous enamel.

Regular cleaning is recommended. For easier cleaning, wipe up any spillages immediately.

<b>Cooktop</b>		
<b>Part</b>	<b>Finish</b>	<b>Recommended Cleaning Method</b>
Cooktop surface	Toughened glass	Hot soapy water, non-abrasive cleaner if necessary.
<b>Outside of range</b>		
<b>Part</b>	<b>Finish</b>	<b>Recommended Cleaning Method</b>
Door, door surround and storage drawer exterior	Enamel or paint	Hot soapy water, soft cloth. Any stubborn stains, remove with gentle detergent.
	Stainless steel	Chrome & Steel Cleaner and buff with a microfiber cloth.
Sides and plinth	Painted surface	Hot soapy water, soft cloth. Enamel cleaner or chrome & steel cleaner respectively, if necessary.
Back Splash/rear grille	Enamel or stainless steel	Hot soapy water, soft cloth. Cream cleaner, with care, if necessary.
Control panel	Paint, enamel or stainless steel	Warm soapy water. Do not use abrasive cleaners on lettering.
Control knobs/handles & trims	Mercury knobs are aluminium	Warm soapy water, soft cloth. Chrome & steel cleaner if necessary.
Oven door glass/glass lid	Toughened glass	Hot soapy water, non-abrasive cleaner if necessary.
<b>Oven and Broiler</b>		
<b>Part</b>	<b>Finish</b>	<b>Recommended Cleaning Method</b>
Sides, floor and roof of oven (see below)	Enamel	Any proprietary oven cleaner that is suitable for enameled ovens. <b>CAUTION:</b> corrosive/caustic oven cleaners: follow manufacturer's instructions. <b>DO NOT</b> allow contact with the oven elements
Oven interior	Porcelain enamel	Branded oven cleaner suitable for enamel surfaces.
Oven shelves, Handyrack, broiler trivet, Handygrill rack	Chrome	An oven interior cleaner that is suitable for chrome. Soap filled pad. Dishwasher.
Broiler pan/meat tin (some models only)	Enamel	Hot soapy water. Soap filled pad. Dishwasher.

**Table 6.1**

## 7. Troubleshooting

---

**⚠ All servicing and repairs must be carried out by a qualified service engineer.**

**NOTE:** The induction cooktop is able to self-diagnose a number of problems and can show this information to the user via the cooktop control display. Error codes may be displayed if your cooktop has developed a fault.

If your appliance reports an error or is not working, you may be able to correct the fault by consulting the following.

### **Error code E2 is displayed**

The electronic unit is too hot. Please check the installation of the range, making sure that there is sufficient ventilation. In extreme cases, if a cooking utensil has been allowed to boil dry this error code may also be displayed. If in doubt please contact your installer or a qualified repair engineer.

### **No display operation**

Over voltage or loss of supply voltage to the range. If in doubt please contact your installer or a qualified repair engineer.

### **Error code U400 is displayed**

The range has been incorrectly connected. The control will switch off after approximately 1 second and the error code will be permanently displayed.

Consult your installer or a qualified repair engineer.

### **Error code Er followed by a number is displayed**

The appliance has developed an internal technical fault that cannot be rectified by the user.

Consult your installer or a qualified repair engineer.

### **The fuse blows or the RCD trips regularly**

Please contact your installer or a qualified repair engineer.

### **The range will not switch on**

Has the wiring system in the house blown a fuse or tripped an earth leakage circuit breaker?

Has the range been correctly connected to the mains supply?

### **The induction cooktop is noisy**

When using the induction cooktop there may be some 'noise' emitted from the pan. This is normal and may be most noticeable when cooking on high power settings or if 5 pans are used simultaneously. The type of pan may also contribute to induction 'noise'.

### **Steam is coming from the oven**

When cooking foods with a high water content (e.g. oven chips) there may be some steam visible at the rear grille. Take care when opening the oven door, as there may be a momentary puff of steam when the oven door is opened. Stand well back and allow any steam to disperse.

### **An oven fan is noisy**

The sound of the oven fan may change as the oven heats up – this is perfectly normal.

### **What cleaning materials are recommended for the range?**

See the 'Cleaning' section for a full list of recommended cleaning materials.

**⚠ We DO NOT recommend corrosive or caustic cleaners as these may damage your range.**

### **The knobs get hot when I use the oven, can I avoid this?**

Yes, this is caused by heat rising from the oven, and heating them up. **DO NOT** leave the oven door open.

### **The fascia gets hot when I use the oven or broiler**

The range is cooled by a fan. If the fascia becomes excessively hot when the range is in use then the cooling fan may have failed. Should this occur please contact your installer, a qualified repair engineer or Customer Service to arrange for its repair.

### **If there is an installation problem and I don't get my original installer to come back to fix it who pays?**

You do. Service organizations will charge for their call outs if they are correcting work carried out by your original installer. It is in your interest to track down your original installer.

### **Food is cooking too slowly, too quickly, or burning**

Cooking times may differ from your previous oven. Check that you are using the recommended temperatures and shelf positions.

See the oven cooking guide section of the instructions. The oven control settings and cooking times are intended to be used only as a guide.

Individual tastes may require the temperature to be altered either way, to get the results you want. Try cooking at a higher or lower temperature setting.

### The oven is not cooking evenly

If you are cooking a large item, be prepared to turn it round during cooking.

If two shelves are used, check that space has been left for the heat to circulate. When a baking sheet is put into the oven, make sure it is placed centrally on the shelf.

Check that the door seal is not damaged.

A dish of water when placed on the shelf should be the same depth all over. (For example, if it is deeper at the back, then the back of the range should be raised up or the front lowered.)

If the range is not level arrange for your supplier to level it for you.

### Oven not coming on

Is the power on?

If not there may be something wrong with the power supply.  
Is the range supply on at the circuit breaker?

Have you set a cooking function?

### Oven temperature getting hotter as the range gets older

If turning the knob down has not worked or only worked for a short time then you may need a new thermostat. This should be changed by a qualified service engineer.

### The door is misaligned

The bottom hinge of either oven door can be adjusted to alter the angle of the door (**Fig. 7.1**). Loosen the bottom hinge fixing screws and use the notch and a flat bladed screwdriver to move the position of the hinge to set the hinge position (**Fig. 7.2**).

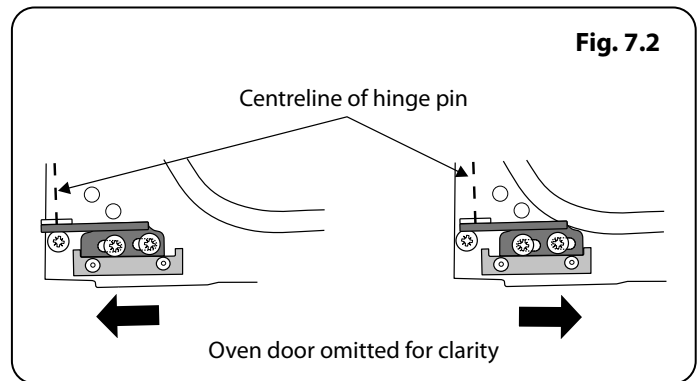
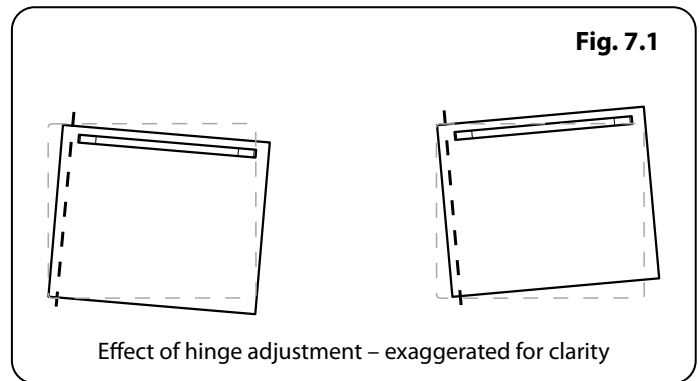



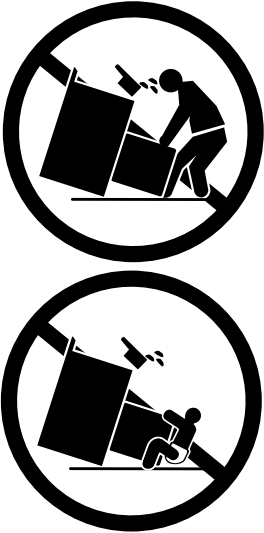

## 8. Installation Instructions

# WARNING!

The anti-tip device supplied with this range must be installed when the appliance is installed. This will reduce risk of tipping of the appliance from abnormal usage or by excessive loading of the oven door.

	<b>▲WARNING!</b>
	<ul style="list-style-type: none"> <li>• ALL RANGES CAN TIP.</li> <li>• INSTALL ANTI-TIP BRACKET PACKED WITH RANGE - SEE INSTALLATION INSTRUCTIONS.</li> <li>• A CHILD OR ADULT CAN TIP THE RANGE AND BE KILLED.</li> <li>• ENGAGE THE RANGE TO THE ANTI-TIP DEVICE - SEE INSTALLATION INSTRUCTIONS.</li> <li>• RE-ENGAGE THE ANTI-TIP DEVICE IF THE RANGE IS MOVED.</li> <li>• FAILURE TO DO SO CAN RESULT IN DEATH OR SERIOUS BURNS TO CHILDREN OR ADULTS.</li> </ul>

The following symbols are related to Safety and are used on the product and throughout this manual.

Meaning / Description	Symbol	Meaning / Description	Symbol
<p><b>WARNING / CAUTION</b></p> <p>An appropriate safety instruction should be followed or caution to a potential hazard exists.</p>		<p><b>HEAVY</b></p> <p>This product is heavy and reference should be made to the safety instructions for provisions of lifting and moving.</p>	
<p><b>DANGEROUS VOLTAGE</b></p> <p>To indicate hazards arising from dangerous voltages.</p>		<p><b>DISCONNECT MAINS SUPPLY</b></p> <p>Disconnect incoming supply before inspection or maintenance.</p>	
<p><b>PROTECTIVE EARTH (GROUND)</b></p> <p>To identify any terminal which is intended for connection to an external conductor for protection against electric shock in case of a fault, or the terminal of a protective earth (ground) electrode.</p>			

**READ THESE INSTRUCTIONS FULLY BEFORE USE  
SAVE THESE INSTRUCTIONS FOR FUTURE REFERENCE SAVE THE INSTALLATION  
INSTRUCTIONS FOR THE LOCAL ELECTRICAL INSPECTOR'S USE**

## INSTALLATION

Check the appliance is electrically safe when you have finished.

## 9. Service and parts

Firstly, please complete the appliance details below and keep them safe for future reference – this information will enable us to accurately identify the particular appliance and help us to help you. Filling this in now will save time and inconvenience if you later have a problem with the appliance. It may also be of benefit to keep your purchase receipt with this leaflet. You may be required to produce the receipt to validate a warranty field visit.

<b>Dealer's Name and Address</b>	
<b>Name of Appliance</b>	
<b>Appliance Serial Number*</b>	
<b>Fuel Type</b>	
<b>Date of Purchase</b>	
<b>Installer's Name, Address and Telephone No.</b>	
<b>Date of Installation</b>	

\* This information is on the appliance data badge.

### If you have a problem

In the unlikely event that you have a problem with your appliance, please refer to the rest of this booklet, especially the problem solving section, first to check that you are using the appliance correctly.

If you are still having difficulty, please contact Tech Support at 800.914.4799 or email [techsupp@middlebyresidential.com](mailto:techsupp@middlebyresidential.com).

#### Please note

For warranty information or to register your AGA range, email [customersupport@middlebyresidential.com](mailto:customersupport@middlebyresidential.com). You may also refer to the warranty document provided with the appliance or contact 888.845.4641 Option 3.

### Out of warranty

We recommend that our appliances are serviced regularly throughout their life to maintain the best performance and efficiency. The frequency of service will depend on usage – for normal usage once a year should suffice. Service work should only be carried out by a suitably Authorized Person.

### Spare parts





To maintain optimum and safe performance, we recommend that only genuine spare parts are used. **DO NOT** use re-conditioned or unauthorized controls. Contact 888.845.4641 Option 1 or email [parts@middlebyresidential.com](mailto:parts@middlebyresidential.com).

## INSTALLATION



Check the appliance is electrically safe when you have finished.

# 10. Installation safety instructions







## Regulations

-  Installation of this range must conform with local codes.
-  This range has been designed and certified to the requirements of UL 858 & CSA C22.2 E60335-2-6.
-  This appliance is to be installed in accordance with National, regional and electrical codes by a qualified person.
-  The range must be electrically grounded in accordance with local codes or, in the absence of local codes, in accordance with the National Electrical Code (NFPA 70, latest edition). In Canada, electrical grounding must be in accordance with the current CSA C22.1 Canadian Electrical Code Part 1 and/or local codes.





### IMPORTANT!







-  Observe all governing codes and ordinances.
-  Save these instructions for the local electrical inspector's use.

## For your safety

-  **DO NOT store or use combustible materials, gasoline or other flammable vapors and liquids in the vicinity of this or any other appliance.**
-  This appliance must be grounded.
-   Isolate electrical supply before installation.
-  This appliance is heavy. Ensure you have the correct facilities to complete the move. To find the weight of the appliance refer to the "Technical data".
-  Ensure all clearances are followed. Refer to "Positioning the range".
-  Improper installation, adjustment, alteration, service or maintenance can cause injury or property damage. Refer to this manual. For assistance or additional information, consult a qualified, appointed AGA Service Agent.

### IMPORTANT!

-  Remove all packing material and literature from ovens before connecting the electrical supply to range.
-  Have your range installed by a qualified installer.
-  Your range must be electrically grounded in accordance with local codes or, in the absence of local codes, in accordance with the National Electrical Code (NFPA 70, latest edition).
-  **DO NOT install your range on a substrate that cannot withstand 180 °F (82 °C).**

-  **DO NOT install your range directly onto carpeting. Ensure an appropriate, non-combustible, substrate is installed prior to installing the range.**
-  **Make sure the wall coverings around the range can withstand heat generated by the range up to 200 °F (93 °C).**
-  **Avoid placing cabinets above the range. There must be a gap of at least 30" (762 mm) between the top of the range and any combustible surface above it.**
-  **If a ventilating hood is installed above the range follow the installation instructions supplied with the hood.**
-  **Items of interest to children should not be stored above a range – children climbing on the range to reach items could be seriously injured.**
-  **To eliminate the risk of burns or fire by reaching over heated surface units, cabinet storage space located above the surface units should be avoided.**

## Location of the range

The range may be installed in a kitchen/kitchen dining area but **NOT** in a room containing a bath or shower.



The range is freestanding and should not be placed on a separate base.

The range should be positioned on a solid substrate.

-  **Your range is heavy DO NOT place on soft floor coverings, such as cushioned vinyl or carpeting.**

Use care when moving the range on cushioned vinyl or carpeted flooring.

When the floor covering ends at the front of the range, the area that the range will rest on should be built up to the same level or higher than the floor covering.

-  **IMPORTANT - This will allow the range to be moved for cleaning or servicing. Also, make sure your floor covering will withstand 180°F. (See the Installation Safety Instructions section).**
-  **IMPORTANT - Make sure the wall coverings around your range can withstand the heat generated (up to 200°F) by the range. (See the Installation Safety Instructions section).**

## INSTALLATION

Check the appliance is electrically safe when you have finished.

# 11. Installation

You will need the following equipment to complete the range installation satisfactorily:

- Multimeter (for electrical checks).
- Allen keys (provided in pack).

You will also need the following tools:

1. Steel tape measure
2. Cross-head screwdriver
3. Flat head screwdriver
4. Spirit level
5.  $\frac{9}{16}$ " (13 mm) wrench or socket wrench
6.  $\frac{5}{16}$ " (8 mm) socket wrench or socket wrench

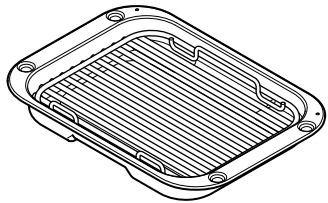
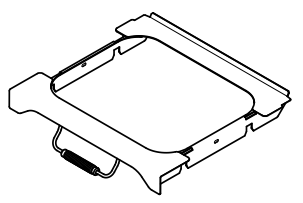
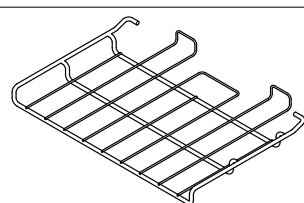
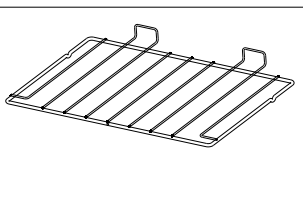
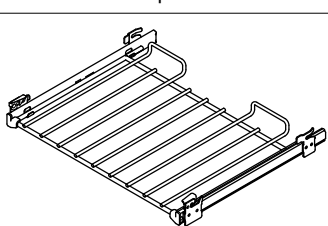
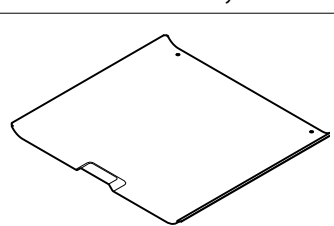
Included Accessories:	
Broiler pan & trivet	Broiler pan cradle
	
1 drop shelf	2 flat shelves
	
2 telescopic shelves	2 Oven Base Trays
	

## INSTALLATION

Check the appliance is electrically safe when you have finished.

### Positioning the range

**Fig. 11.1, Fig. 11.2 and Fig. 11.3** show the minimum recommended distance from the range to nearby combustible surfaces (see **Table 11.1**).

We recommend a gap of no more than  $\frac{3}{16}$ " (5 mm) (see **Table 11.1**) either side of the appliance for moving the range. It must be possible to move the range in and out for cleaning and servicing.

Cooktop should be level with, or above, any adjacent counter top (**Fig. 11.1**).

\*Any rangehood should be installed in accordance with the hood manufacturer's instructions.

\*\*Any splashback must be fitted in accordance with the manufacturer's instructions. Allowance should be made for the additional height of the flue trim, which is fitted to the rangetop.

Surfaces of furniture and walls at the sides and rear of the appliance should be heat, splash and steam resistant. Certain types of vinyl or laminate kitchen furniture are particularly prone to heat damage and discoloration.

We cannot accept responsibility for damage caused by normal use of the range to any material that de-laminates or discolors at temperatures less than 149°F/65°C above room temperature.

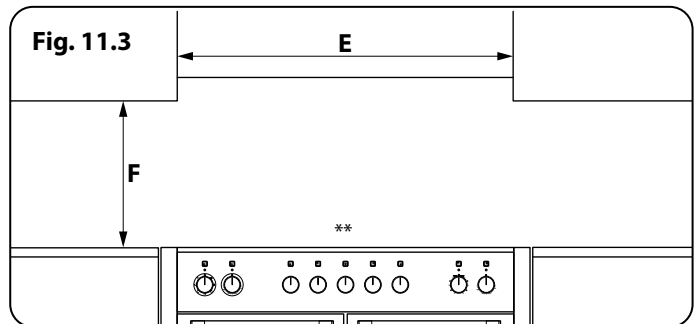
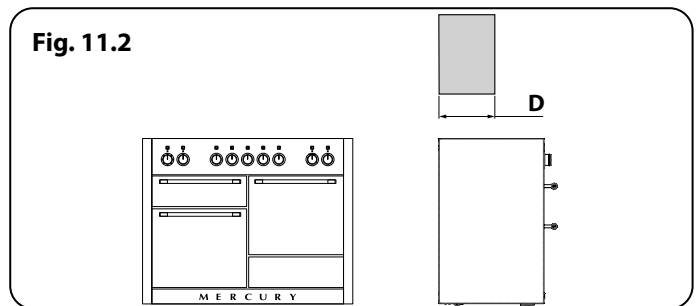
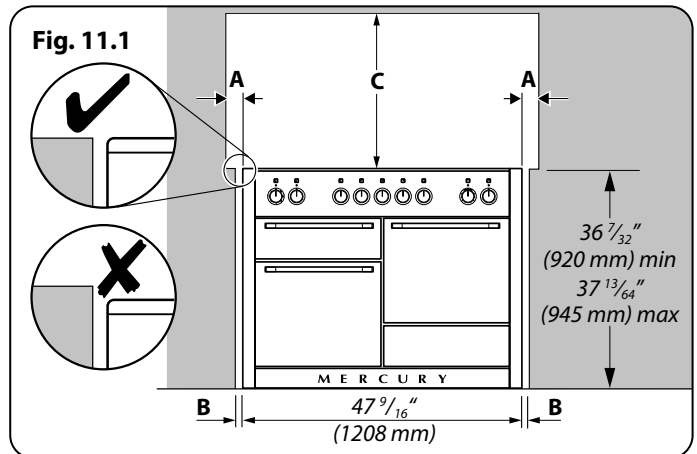

### Clearances to combustibles

Dimension	Description	USA	Canada
<b>A</b>	Gap between side of appliance and adjacent vertical surface ABOVE cooktop level	1 $\frac{3}{16}$ " (30 mm) <sup>1</sup>	1 $\frac{3}{16}$ " (30 mm) <sup>1</sup>
<b>B</b>	Gap between side of appliance and adjacent vertical surface BELOW cooktop level	$\frac{3}{16}$ " (5 mm)	$\frac{1}{2}$ " (12 mm)
<b>C</b>	Gap between cooktop level and any horizontal combustible surface	31 $\frac{1}{2}$ " (800 mm) <sup>2</sup>	31 $\frac{1}{2}$ " (800 mm) <sup>2</sup>
<b>D</b>	Maximum depth of cabinets installed above the top surface cooking sections	13" (330 mm)	13" (330 mm)
<b>E</b>	Minimum distance between horizontal surfaces less than dimension C	47 $\frac{7}{16}$ " (1208 mm)	47 $\frac{7}{16}$ " (1208 mm)
<b>F</b>	Minimum distance between horizontal cabinets and worktop surfaces adjacent to range	16 $\frac{5}{32}$ " (410 mm)	16 $\frac{5}{32}$ " (410 mm)

<sup>1</sup> For non-combustible surfaces (such as unpainted metal or ceramic tiles) this gap is not required

<sup>2</sup> This dimension can be reduced to 24" (610 mm) if the bottom of the wooden or painted metal cabinet is preserved with a non-combustible material

**Table 11.1**

## INSTALLATION

Check the appliance is electrically safe when you have finished.

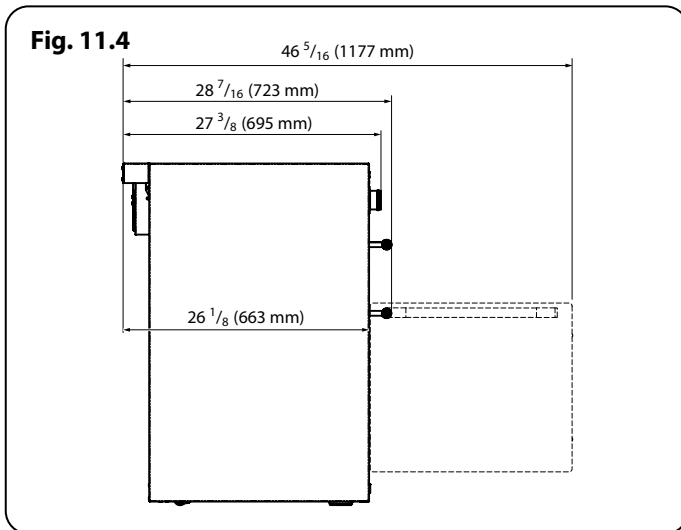

The depth of the range is 28 <sup>7</sup>/<sub>16</sub>" (723 mm) overall (**Fig. 11.4**).

If the range is near a corner of the kitchen, a clearance of 3 <sup>1</sup>/<sub>2</sub>" (90 mm) is required to allow the oven doors to open (**Fig. 11.5**). The actual opening of the doors is slightly less but this allows for some protection of your hand as you open the door.

### When fitting between kitchen cabinets

We recommend a gap of 48" (1218 mm) between units to allow for moving the range. **DO NOT** box the range in – it must be possible to move the range in and out for cleaning and servicing.

- A. In the USA leave a gap of at least <sup>1</sup>/<sub>5</sub>" (5 mm) on either side of the range (a 48" (1218 mm) gap between units). The range should be positioned centrally.
- B. For Canada leave a gap of at least <sup>1</sup>/<sub>2</sub>" (12 mm) on either side of the range (a 48 <sup>1</sup>/<sub>2</sub>" (1232 mm) gap between units). The range should be positioned centrally.

We also recommend that you **DO NOT** final fix any adjacent cabinets until the range is installed. Decorative mouldings or handles on cabinet doors and fronts may interfere with the opening of the oven doors.

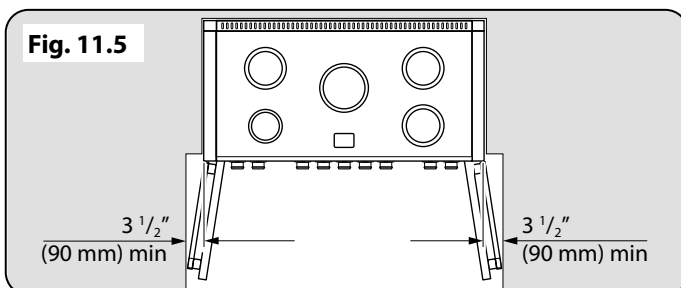

### Moving the range

 **On no account try and move the range while it is plugged into the electricity supply.**

 **This appliance is heavy. Ensure you have the correct facilities to complete the move. To find the weight of the appliance refer to the "Technical data".**

We recommend that two people manoeuvre the range. Make sure that the floor covering is firmly fixed, or removed, to prevent it being disturbed when moving the range around.

To help you, there are two levelling rollers at the back, and two screw-down levelling feet at the front.

Remove the polystyrene base pack. From the front, tilt the range forward and remove the front half of the polystyrene base (**Fig. 11.6**). Repeat from the back and remove the rear half of the polystyrene base. Also remove cardboard base tray.

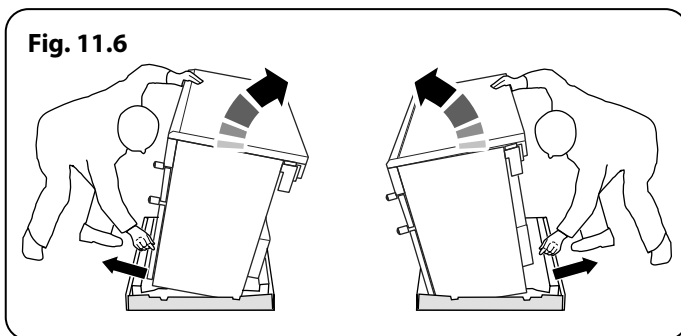

## INSTALLATION

Check the appliance is electrically safe when you have finished.

# 12. Fitting the flue, flue vent and side panels

### Checking the Parts:

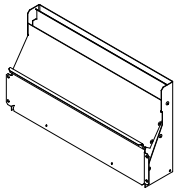
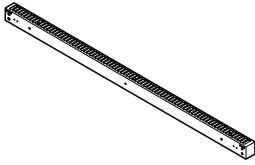
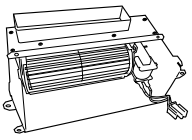
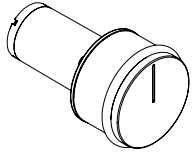
Flue	Flue Vent
	
Fan Assembly	Control knobs x 9
	

### Fitting the knobs

1. Gently push-fit the control knobs onto the spindles.

### Fitting the flue

1. Remove the four screws from the broiler flue opening (**Fig. 12.1**).
2. Present the removable flue up to broiler flue opening. Make sure that the bottom flange of the removable flue fits inside the fixed flue, secure in place with the four screws (**Fig. 12.1**).

### Fitting the flue vent

1. Loosen the three nuts and bolts in the back of the hotplate (**Fig. 12.2**).
2. Fit the flue vent over the bolts and slide down (**Fig. 12.2**). Tighten the nuts to secure.

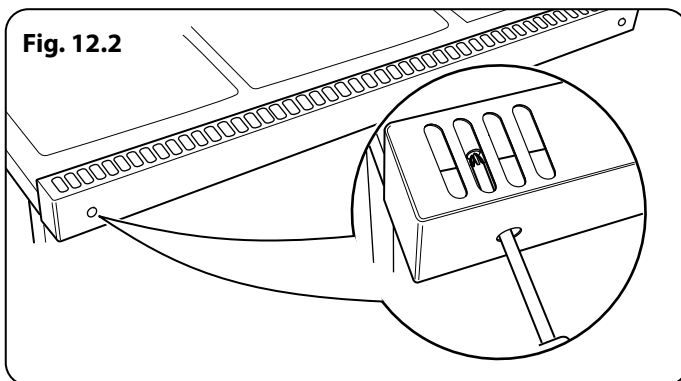
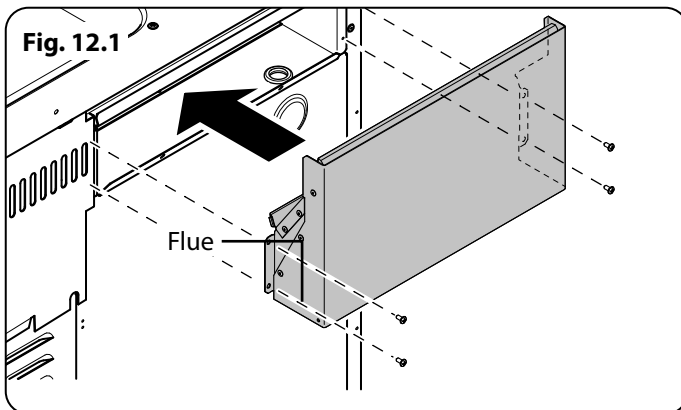

## INSTALLATION

Check the appliance is electrically safe when you have finished.

### Fitting the cooling fan box

1. Remove the six screws where the cooling fan box will be fixed **Fig. 12.3**.
2. The shape of the molex plug should match the socket. Gently connect the molex plug to the molex connector socket **Fig. 12.4**.
3. The cooling fan has two tabs which connects to the slots underneath the flue vent. Gently align the cooling fan box tabs to the slots underneath the flue vent **Fig. 12.5**.
4. Replace the six screws **Fig. 12.6**.

**⚠ Before fitting the side panels, it is recommended that the required height of the range is set. This will simplify the Side Panels fitting procedure.**

### Setting the height

**⚠ You are recommended to use a spirit level on the cooktop to ensure the range is level.**

The front feet and rear rollers can be adjusted to level the range (**Fig. 12.7**).

1. To adjust the height of the rear of the range, fit a 13 mm adjustable or socket wrench onto the hexagonal adjusting nut.
2. Rotate the nut – clockwise to raise – counter-clockwise to lower. Make sure to lower **BOTH REAR ROLLERS**.
3. To set the front turn the feet bases to raise or lower.

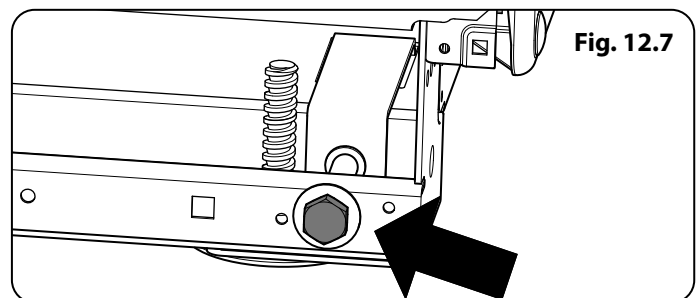
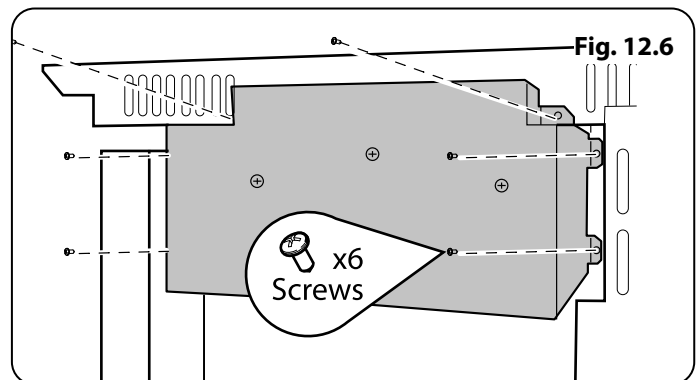
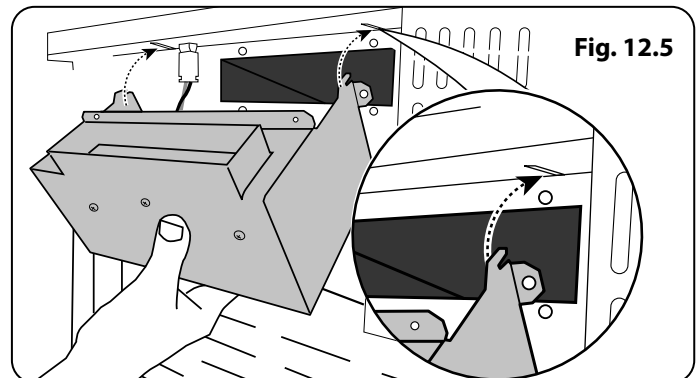
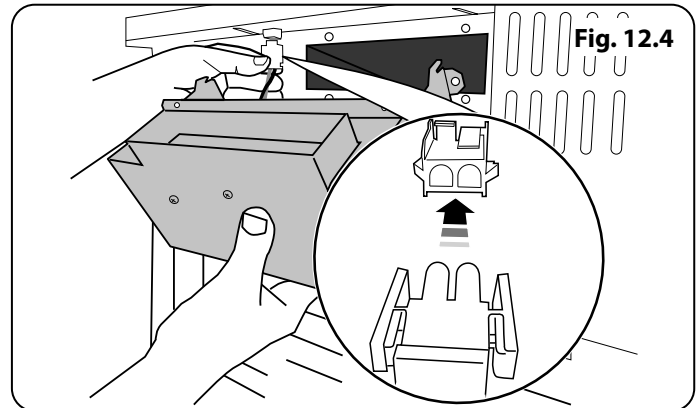
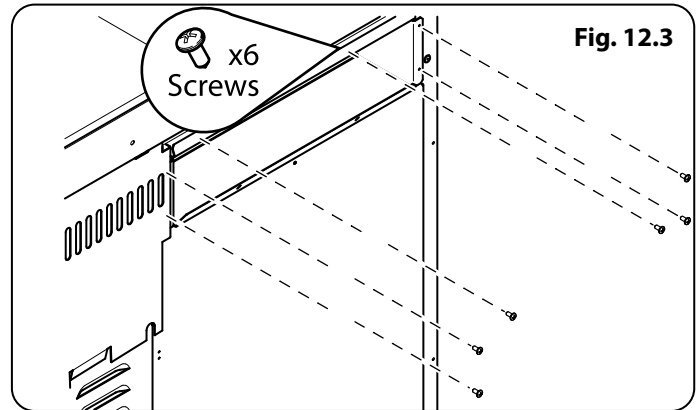

## INSTALLATION

Check the appliance is electrically safe when you have finished.

### Fitting the side panel rear retaining brackets

1. Located at the bottom left and right **rear** corner of the range, remove the two screws (**Fig. 12.8**).
2. Fit the left and right retaining brackets to the base frame and refit and tighten the screws (**Fig. 12.8**).

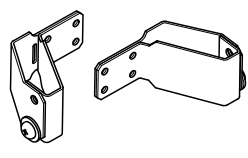
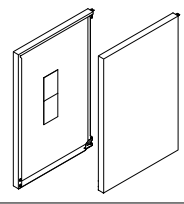
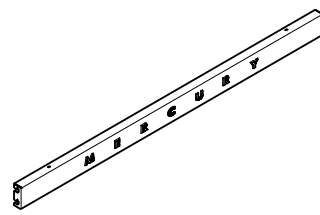
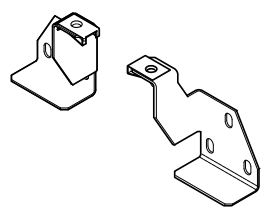
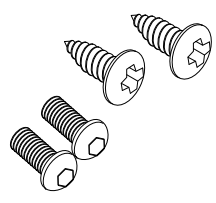
Checking the Parts:	
Side panel rear retaining brackets A052064 - Right-hand A052067 - Left-hand	Side panels x 2
	
Bottom Panel (Toe kick) Color matched to range	Bottom Panel (Toe kick) Front Mounting Brackets Q050877 - Left-hand Q050878 - Right-hand
	
Screws supplied 2x Machine Screw 2x Self-Tapping Screw	
	

**Fig. 12.8**

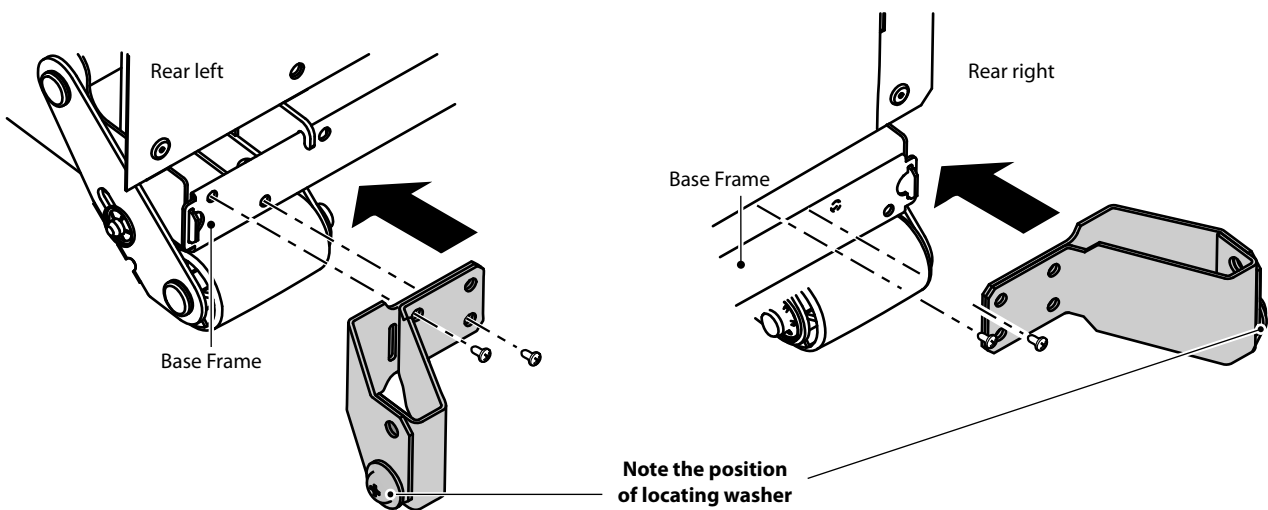

## INSTALLATION

Check the appliance is electrically safe when you have finished.

### Fitting the side panels

1. Loosen the screw in the flue vent (**Fig. 12.9**).
2. Inside the top of the side panel top are two tabs. Attach the self adhesive gaskets to each tab and connect these tabs into the cut-outs in the top edge of the range (**Fig. 12.10**).
3. Slide the side panel back so that the **side panel bracket** in the base connects to the **rear retaining washer** and the slotted tab at the top rear connects onto the screw in the flue vent (**Fig. 12.11**).
4. Check everything is firmly connected and tighten the screw in the flue vent to secure the side panel in position (**Fig. 12.9**).

**NOTE:** The bottom front of the side panels will be loose. These are secured once the bottom panel (toe kick) is fitted.

**NOTE:** If a side panel is loose, fit one of the extra gaskets to the inner face of the front bracket locating tabs and refit.

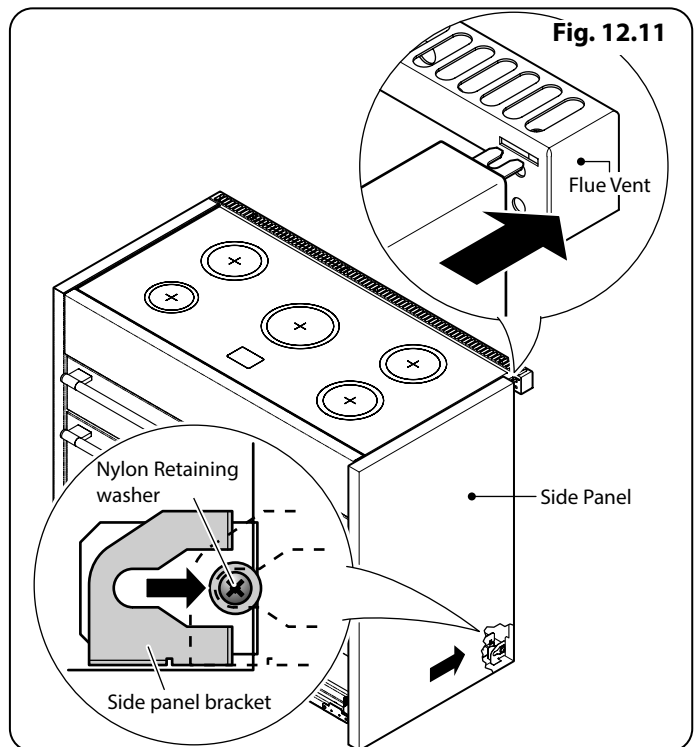
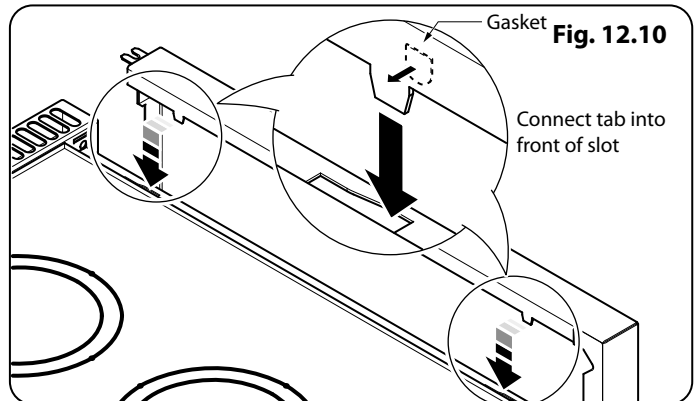
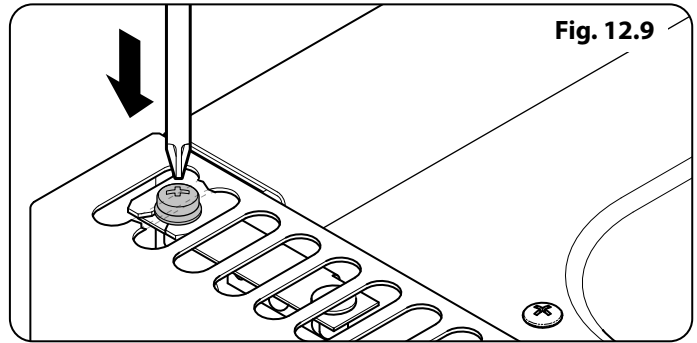

## INSTALLATION

Check the appliance is electrically safe when you have finished.

Fig. 12.12

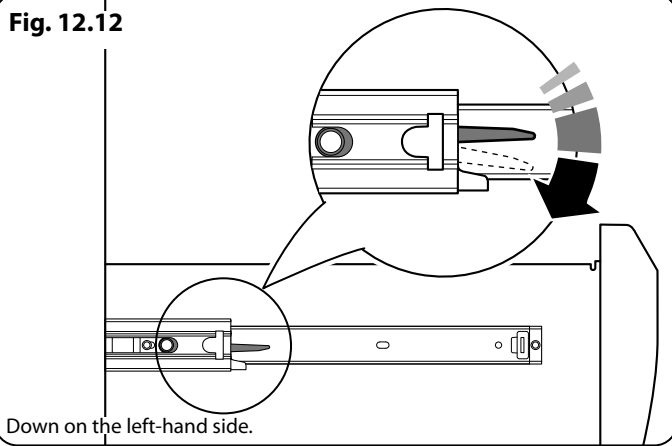

Fig. 12.13

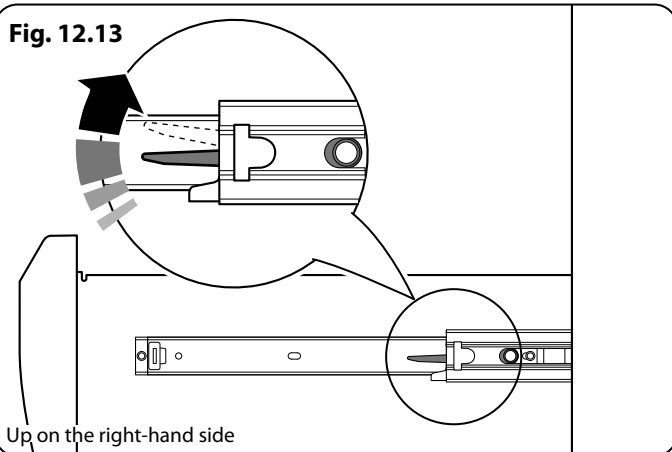

Fig. 12.14

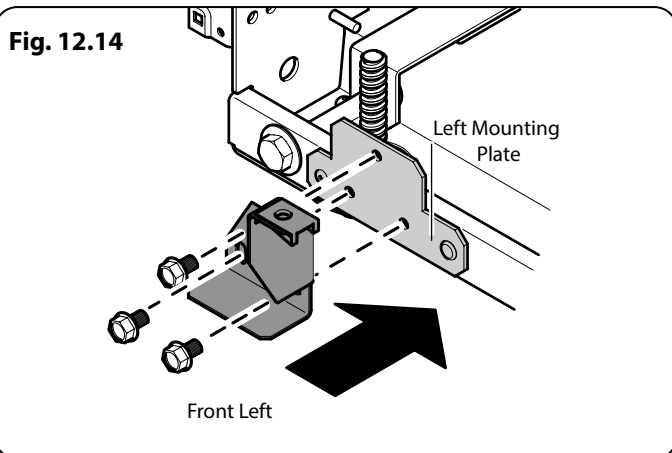
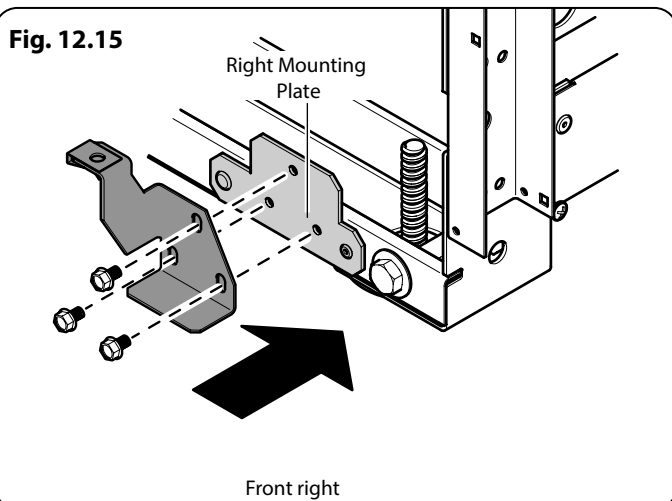

Fig. 12.15



## Fitting the front mounting brackets

1. Open the right-hand oven door and pull the drawer out to its furthest point.
2. Push the ends of the plastic clips (**Fig. 12.12** and **Fig. 12.13**) to release the catches holding the drawer to the side runners. At the same time pull the drawer forward and away from the side runners.

**▲ For safety's sake make sure the drawer runners are out of the way.**

3. On the front of the range base there are two mounting plates. Remove the three fixing screws from each plate (**Fig. 12.14**).
4. Fit the left and right-hand front mounting brackets as shown in (**Fig. 12.14** and **Fig. 12.15**). **DO NOT over tighten the mounting screws at this stage.**

## INSTALLATION

Check the appliance is electrically safe when you have finished.

### Fitting the bottom panel *(Toe kick)*

1. Tilt the bottom of the panel slightly to locate the lower slots onto the washers (**Fig. 12.16**). Now rotate the panel to fit over the pins (**Fig. 12.17**).
2. Using the two screws and allen key supplied, loosely fit the bottom panel onto the mounting brackets (**Fig. 12.19**). **DO NOT tighten at this stage.**
3. Adjust the bottom panel to set the gap between the side panels and doors equally (**Fig. 12.18**). When it is positioned correctly, use a suitable flat open-ended spanner to tighten the bracket screws, and then tighten the bottom panel screws (**Fig. 12.19**) with the allen key provided.

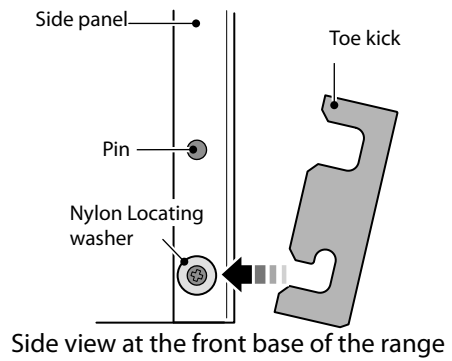

Fig. 12.16

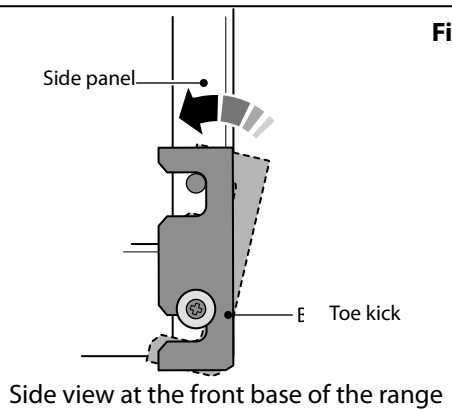

Fig. 12.17

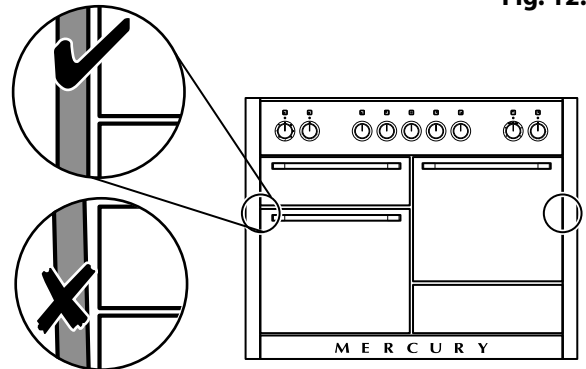

Fig. 12.18

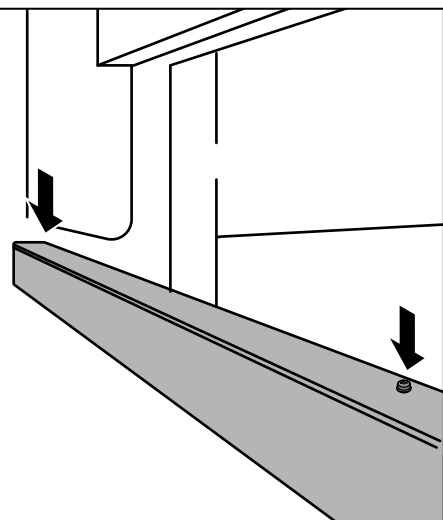
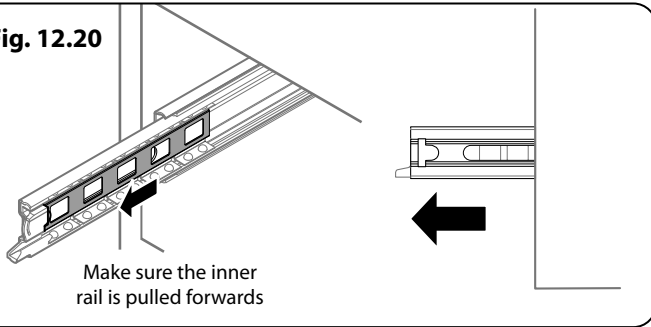

Fig. 12.19

## INSTALLATION

Check the appliance is electrically safe when you have finished.

Fig. 12.20



## Fitting the drawer

1. To fit the drawer, pull the side rails fully out (**Fig. 12.20**).
2. Carefully move the drawer back between the rails and rest it on the side rails.
3. At each side, hold the front of the drawer and pull the side rail forward so that the clips click into position, holding the drawer to the side rails (**Fig. 12.21**).

Fig. 12.21

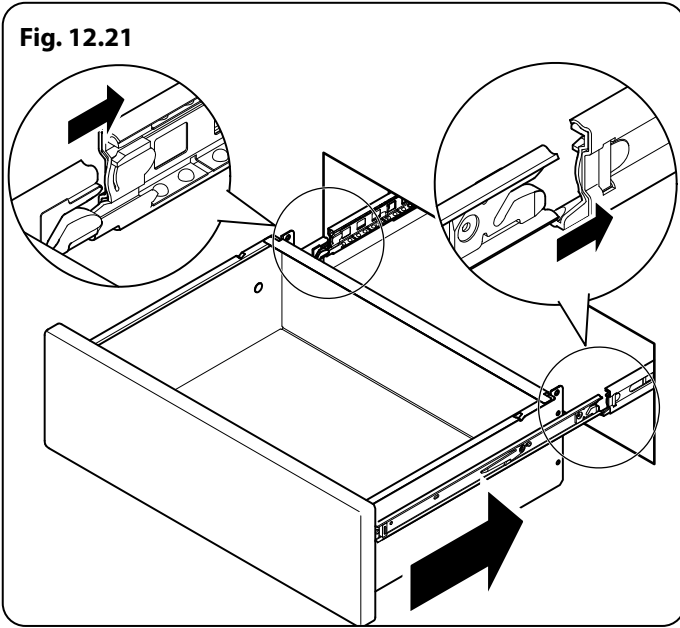

## INSTALLATION

Check the appliance is electrically safe when you have finished.

### Fitting the anti-tip device

1. A suitable anti-tip device is supplied and shown in **Fig. 12.22**.
2. When fitting the anti-tip bracket (**Fig. 12.22** and **Fig. 12.23**), adjust the bracket to give the smallest practicable clearance between the bracket and the engagement slot in the rear of the range.
3. Fit the bracket so that it engages as far as possible over the chassis of the range.

**⚠ DO NOT operate the range before the appliance is in its installed position and the anti-tip devices are engaged.**

**⚠ If the appliance is moved ensure that the anti-tip devices are re-engaged and the range has been returned to its original installed position.**

**⚠ DO NOT step, lean or swing on the range doors or drawer as this could tip the range and result in serious injury or death.**

### Completing the move

1. Open the broiler door and right-hand oven door so that you can get a good grip on the bottom of the fascia panel as you move the range (**Fig. 12.24**).
2. Position the range close to its final position.
3. Check that the anti-tip device is engaged before moving the range into its final, installed position.
4. Re-check that the appliance is level.

**⚠ DO NOT use the door handles or control knobs to manoeuvre the range.**

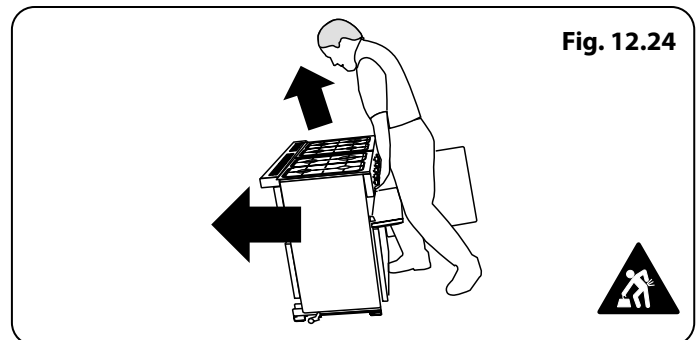
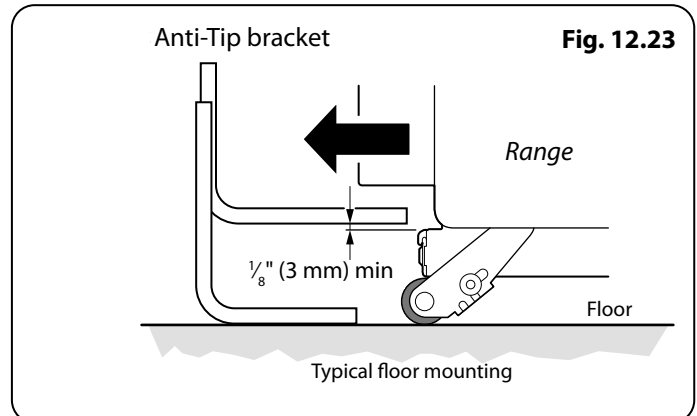
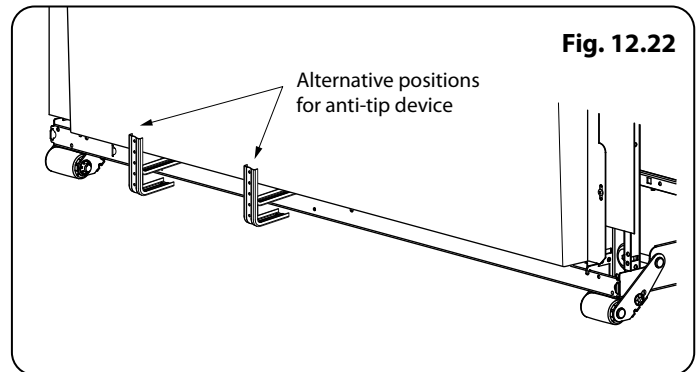

## INSTALLATION

Check the appliance is electrically safe when you have finished.

# 13. Removing the side panels

### DISCONNECT THE ELECTRICAL SUPPLY.

You will need the following equipment to remove the side panels:

- Cross-head screwdriver
- Flat head screwdriver
- Allen keys (provided in pack).

## Removing the storage drawer

1. Pull the drawer out to its furthest point.
2. Push the ends of the plastic clips (**Fig. 13.1** and **Fig. 13.2**) to release the catches holding the drawer to the side runners. At the same time pull the drawer forward and away from the side runners.

**⚠ For safety make sure the drawer runners are out of the way.**

## Removing the bottom panel *(toe kick)*

1. After removing the drawer open the left-hand oven door.
2. Unscrew the two allen head screws (**Fig. 13.3**), lift the bottom panel up and slightly rotate the panel away from the pins (**Fig. 13.4**).

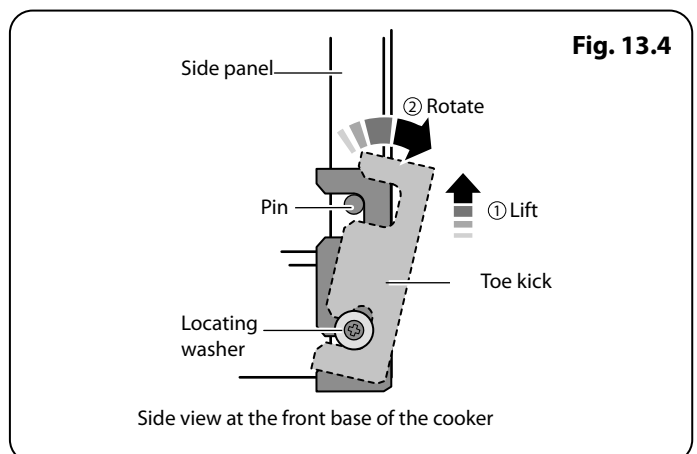
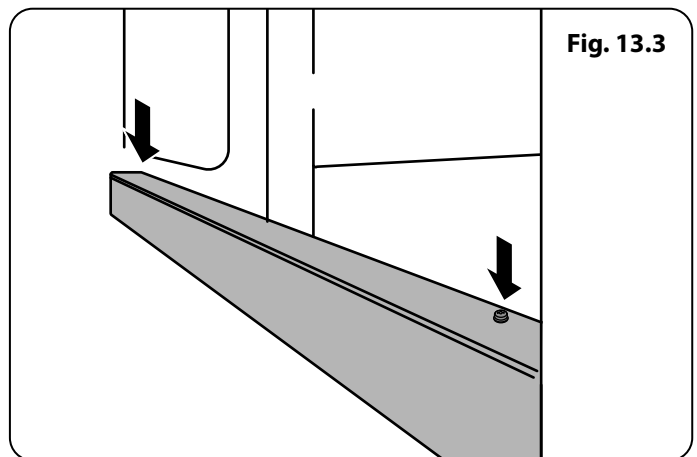
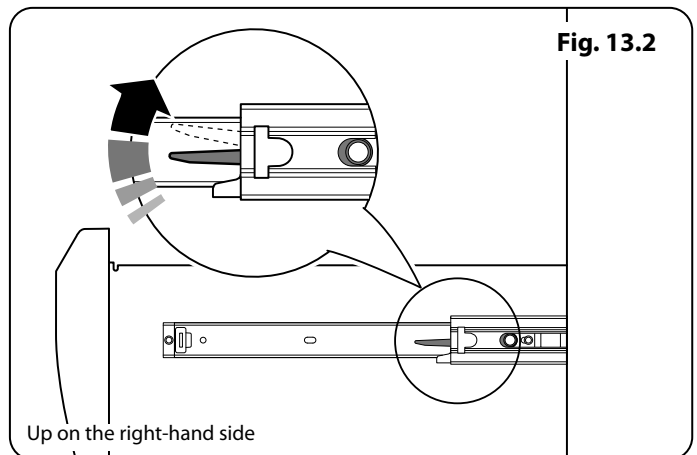
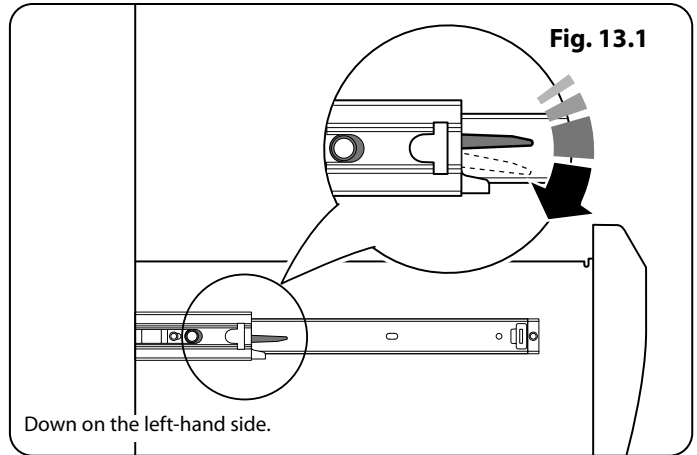

## INSTALLATION

Check the appliance is electrically safe when you have finished.

### Removing the side panels

1. Loosen one screw in the vent (**Fig. 13.5**).
2. Push forward the side panel so that it moves away from the flue vent and the retaining washer (**Fig. 13.6**).
3. Inside the top of the side panel top are two tabs. Move the side panel up and away from the range (**Fig. 13.7**).

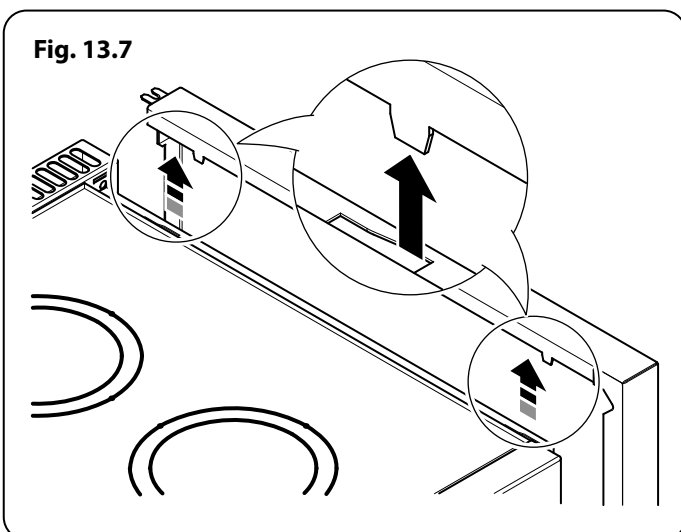
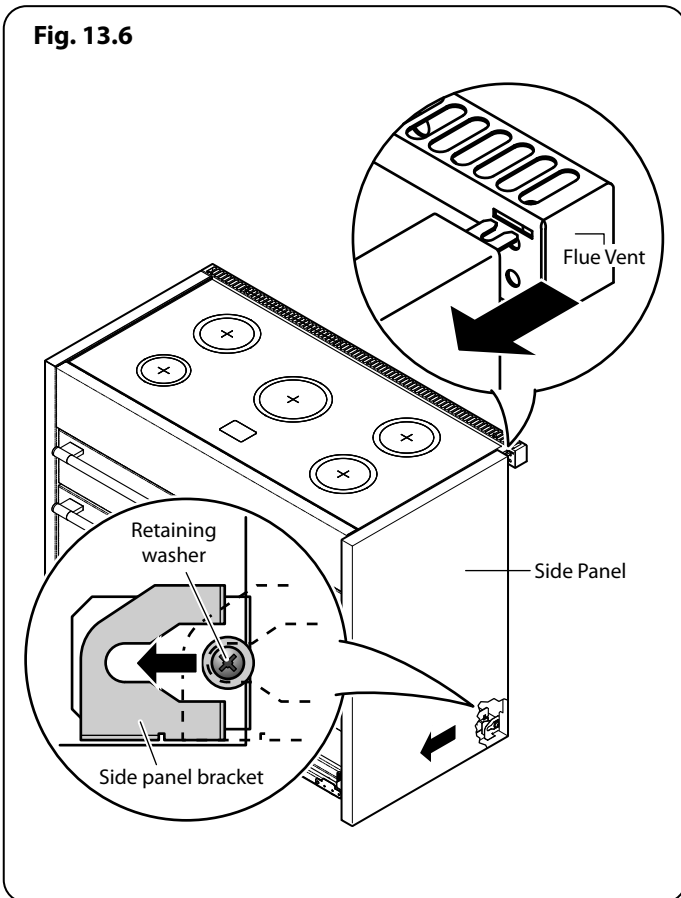
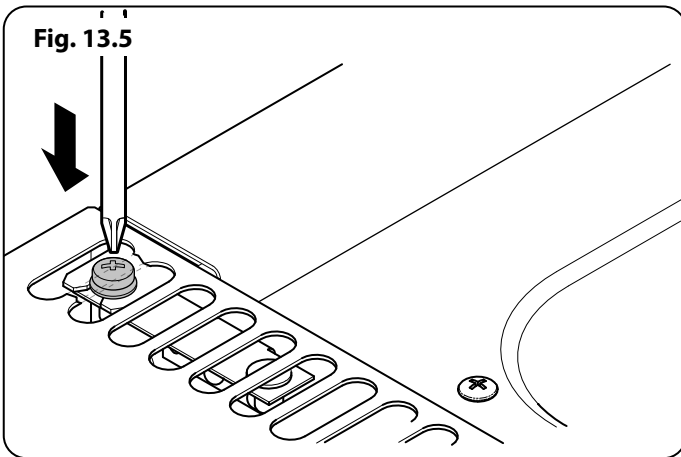

## INSTALLATION

Check the appliance is electrically safe when you have finished.

# 14. Electrical connection

Have your appliance properly installed and grounded by a qualified technician. The installation must conform with local codes or in the absence of local codes in accordance with the National Electrical Code NFPA 70 or the Canadian Electric Code, CSA C22.1.

## Electrical requirements

- ⚠ For personal safety, DO NOT use an extension cord with this appliance. Remove the house fuse or open the circuit breaker before beginning installation.**
- ⚠ WARNING Electrical Grounding Instructions. This appliance is shipped with a (four-prong) grounding plug for your protection against shock hazard and should be plugged directly into a properly grounded receptacle. DO NOT cut or remove the grounding prong from this plug.**
- ⚠ Prior to connecting the power cord to the wall socket, inspect the cable for any damage that may have occurred. In the event of damage please consult your electrical installer.**
- ⚠ Ensure that the power cord is routed so that it cannot become damaged during the installation.**

This appliance must be supplied with the proper voltage and frequency, and connected to an individual, properly grounded branch circuit, protected by a circuit breaker or time-delay fuse, as noted on the rating plate.

Wiring must conform to National Electric Codes. If the electric service provided does not meet the above specifications, have a licensed electrician install an approved outlet.

Because range terminals are not accessible after range is in position, flexible service conduit or cord must be used.

## INSTALLATION

Check the appliance is electrically safe when you have finished.

### Provide proper electrical supply

This range must be supplied with 240 V 60 Hz, and connected to an individual, properly grounded branch circuit protected supply. If the electrical service provided does not meet the above specifications, it is recommended that a licensed electrician install an approved outlet.

This should be connected to an appropriate Branch Circuit protected supply. **NOTE** - load diversity factor has been applied in accordance with NFPA 70 article 220.

### Connecting using the supplied cord and plug

Your range is shipped with a 4-prong NEMA 14-50P plug to be used in a NEMA 14-50R receptacle.

### Recommended electrical outlet location

When connecting using a NEMA 14-50R receptacle, if possible position it so it can be accessed through the opening at the rear of the drawer cavity (**Fig. 14.1**). Alternate location within the shaded area in (**Fig. 14.2**). The distance between the back of the range and the wall is approximately 4" (10.6 cm).

Plug the range power cord into a properly grounded wall receptacle.

 **Disconnect the electrical supply before servicing.**

Fig. 14.1

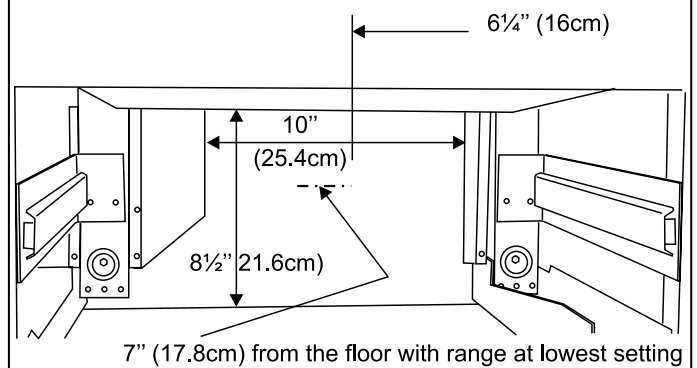

Opening inside the drawer cavity

Fig. 14.2

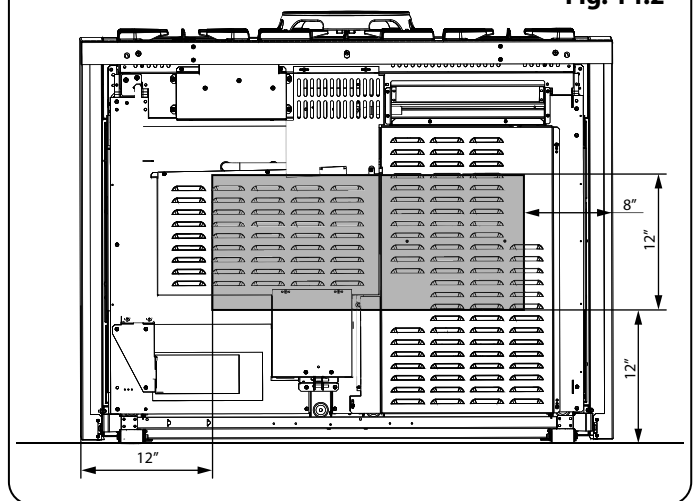

## INSTALLATION

Check the appliance is electrically safe when you have finished.

# 15. Final fitting and checks

---

### **Cooktop check**

Refer to "Range Overview" and check operation of each cooking zone in turn. Be sure to use pans of the correct size and material.

### **Broiler check**

Refer to "Range Overview" and check operation of the broiler and that it heats up\*.

### **Oven check**

Refer to "Range Overview" and check the operation of both ovens\*. Check that the oven fans operate and the ovens heat up.

\* The cooling fan, located at the rear right hand side of the cooktop, should operate with this function.

## **Customer care**

**Installer:** Please complete your details in this guide, inform the user how to operate the range and hand over the instructions.

# 16. Circuit diagram

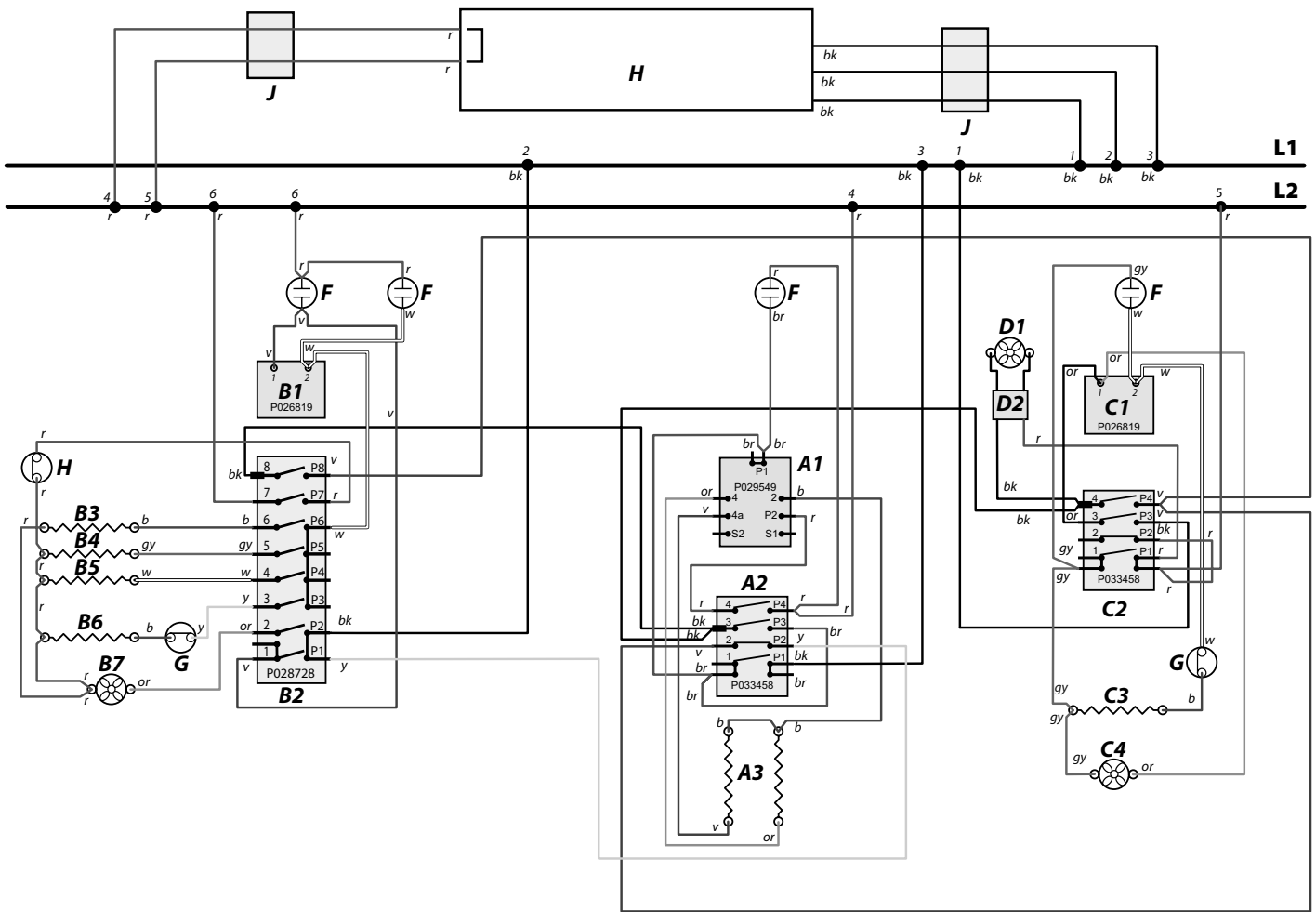

N

Code	Description
<b>A1</b>	Broiler Thermostat
<b>A2</b>	Broiler Controller
<b>A3</b>	Broiler Elements
<b>B1</b>	Left-hand oven thermostat
<b>B2</b>	Left-hand oven switch block
<b>B3</b>	Left-hand bottom element
<b>B4</b>	Left-hand oven top outer element
<b>B5</b>	Left-hand oven top inner element
<b>B6</b>	Left-hand oven fan element
<b>B7</b>	Left-hand oven fan motor

Code	Description
<b>C1</b>	Right-hand oven thermostat
<b>C2</b>	Right-hand oven switch block
<b>C3</b>	Right-hand oven element
<b>C4</b>	Right-hand oven fan motor
<b>D1</b>	Cooling fan motor
<b>D2</b>	Fan connector plug
<b>F</b>	Neon
<b>G</b>	Thermal cut-out
<b>H</b>	Induction Unit
<b>J</b>	Induction Connection Block

Code	Color
<b>b</b>	Blue
<b>br</b>	Brown
<b>bk</b>	Black
<b>or</b>	Orange
<b>r</b>	Red
<b>v</b>	Violet
<b>w</b>	White
<b>y</b>	Yellow
<b>gy</b>	Grey

## 17. Technical data

**INSTALLER:** Please leave these instructions with the user.

**DATA BADGE LOCATION:** Inside base drawer of cavity. Remove the drawer.

**COUNTRY OF DESTINATION:** USA, Canada, Mexico.

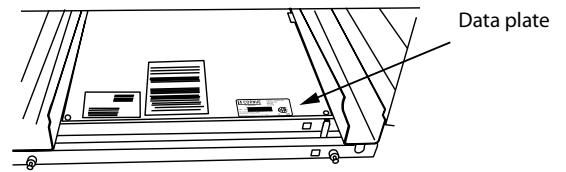

### Connections

Electric Supply	240V 60 Hz
Electric Rating	240V (2 Wire + N + Grd), 60Hz, 18.5 kW *
Branch Circuit Protection	50 A *
Connection Type	NEMA 14-50P
<b>Maximum total electric load 240 V</b> (including oven fans, lights, etc.): * Load demand diversity calculation according to NFPA 70 article 220. Note: The maximum input at any time is given as both ovens fanned and broiler, plus cooling fan.	18.5 kW, (45 A)*

### Dimensions

Overall height	minimum 36 1/16" (916 mm)	maximum 37 3/16" (941 mm)
Overall width	47 9/16" (1208 mm); see 'Positioning of Range'.	
Overall depth	28 5/32" (723 mm)	
Minimum space for cooktop	31 1/2" (800 mm)	
Weight (unpacked)	366 LBS (166 Kg)	

### Oven & broiler ratings

Oven	Left-hand Oven	Right-hand Oven	Broiler
Fan element	2.5 kW	2.5 kW	2.3 / 1.15 kW
Top element	1.2 kW	-	-
Browning element	1.15 kW	-	-
Bottom element	1.0 kW	-	-

### Cooktop ratings

Cooktop Zone	Max	Boost
Front Left	1.4 kW	2.2 kW
Rear Left	1.85 kW	3.0 kW
Center	2.3 kW	3.7 kW
Front Right	1.85 kW	3.0 kW
Rear Right	1.85 kW	3.0 kW

### Oven data

Ovens	Left-hand Multi-function	Right-hand Convection
Maximum total electric load 240 V	2.5 kW	2.5 kW
Usable volume (cubic feet)	2.77	2.79



## CONSUMER WARRANTY

### ENTIRE PRODUCT – LIMITED ONE YEAR WARRANTY

Any cosmetic faults must be reported within 7 days of installation.

AGA warrants the replacement or repair of all parts of this range which prove to be defective in material or workmanship, with the exception of the painted or porcelain enamel finish or plated surfaces, for one year from the date of original purchase. Such parts will be repaired or replaced at the option of AGA without charge, subject to the terms and conditions set out below.

The warranty period against defects in the painted or porcelain enamel finish, or plated surfaces, is 90 days from the date of original purchase. **The warranty does not include replacement of oven lamps.**

### OVEN ELEMENTS - LIMITED SECOND THROUGH THIRD YEAR WARRANTY

AGA warrants the oven heating elements against defects in material or workmanship for an additional two years. These parts will be repaired or replaced at the discretion of AGA without charge, but you pay for labor and transportation subject to the terms and conditions set out below.

### TERMS AND CONDITIONS

1. This warranty applies only for single family domestic use when the range has been properly installed according to the instructions supplied by AGA and is connected to an adequate and proper utility service.

Damage due to faulty installation, improper usage and care, abuse, accident, fire, flood, acts of God, commercial, business or rental use, and alteration, or the removal or defacing of the serial plate, cancels all obligations of this warranty. Service during this warranty must be performed by a factory Authorized Service Person.

**2. Warranty applies to product only in the country in which it was purchased.**

3. AGA is not liable for any claims or damages resulting from any failure of the range or from service delays beyond their reasonable control.
4. To obtain warranty service, the original purchaser **must** present the original Bill of Sale, Model and Serial number. Components repaired or replaced are warranted through the remainder of the original warranty period only.
5. The warranty does not cover expenses involved in making this appliance readily accessible for servicing.
6. This warranty gives you specific legal rights. Additional warranty rights may be provided by law in some areas.
7. Adjustments such as calibrations, leveling, tightening of fasteners, or utility connections normally associated with original installation are the responsibility of the dealer or installer and not that of the Company.

**TO ENSURE PROMPT WARRANTY SERVICE, SEND IN YOUR WARRANTY CARD WITHIN 10 DAYS OF PURCHASE.**

If further help is needed concerning this warranty, contact:

PLACE OF PURCHASE \_\_\_\_\_

DATE OF PURCHASE \_\_\_\_\_

SERIAL NUMBER \_\_\_\_\_

MODEL NUMBER \_\_\_\_\_

Middleby Residential  
4960 Golden Pkwy  
BLDG 3  
Buford, GA 30518  
Business 770.932.7282  
Fax 770.932.7292  
Toll Free Telephone 800.241.9152

## NOTES

---

## NOTES

---







By AGA made for:

**Middleby Residential**

4960 Golden Pkwy

BLDG 3

Buford, GA 30518

Business 770.932.7282

Fax 770.932.7292

Toll Free Telephone 800.241.9152