

Body-Solid®

Built for Life

GDKR100

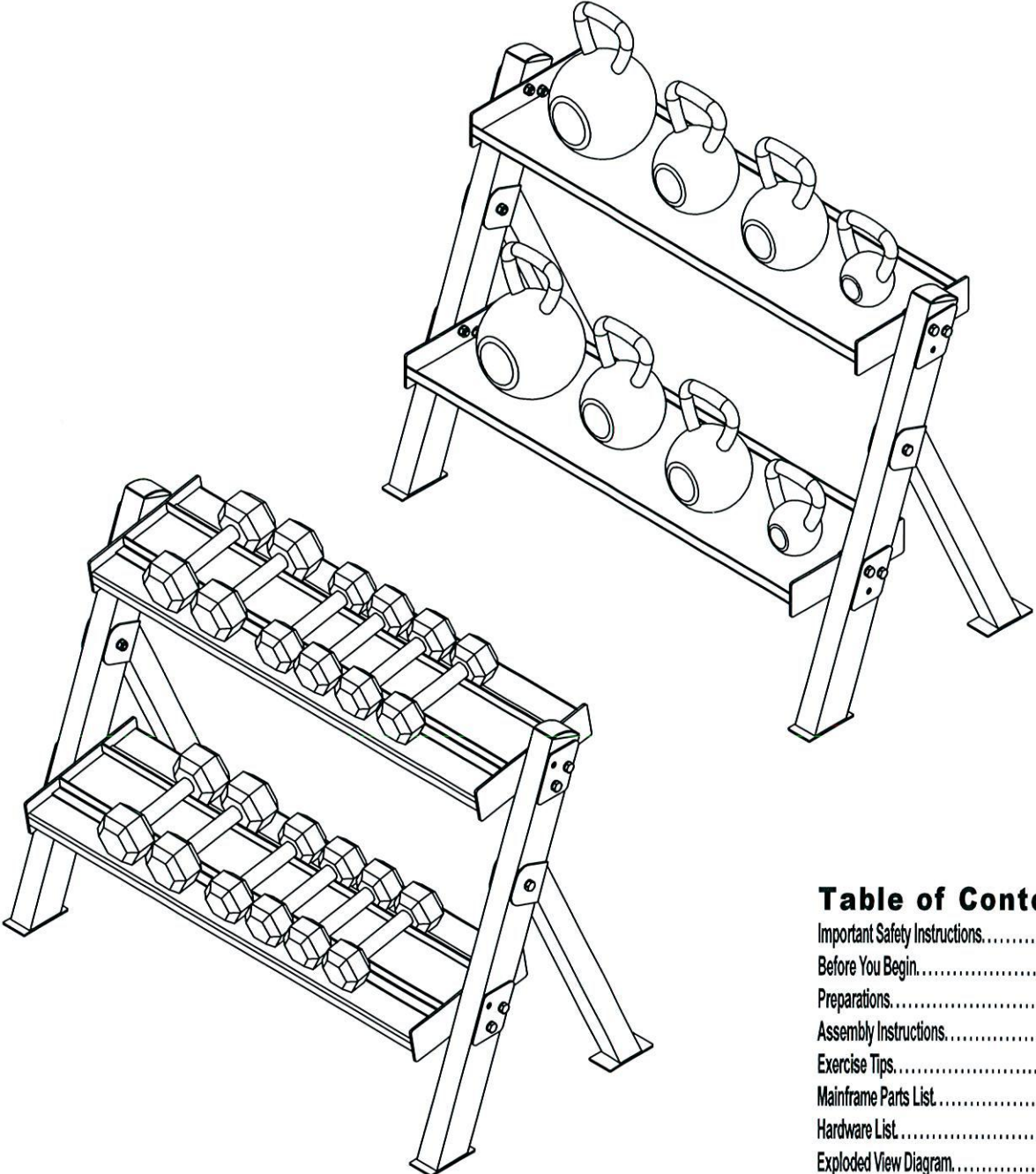

Table of Contents

Important Safety Instructions..... p. 2
Before You Begin..... p. 3
Preparations..... p. 4
Assembly Instructions..... p. 5-11
Exercise Tips..... p. 12-31
Mainframe Parts List..... p. 32
Hardware List..... p. 33
Exploded View Diagram..... p. 34-35

Assembly & Instructions
OWNER'S & MANUAL

STEP

1

Be careful to assemble all components in the sequence they are presented.

LEFT SIDE ASSEMBLY

Assemble the left side of the GDKR100 as described below.

- A. Connect Rear Base Frame (A) to Support Frame (B) using:
One 1 (M10x70 hex head bolt)
Two 4 (M10 washer)
One 3 (M10 nylon lock nut)
- B. Attach Rubber Pad (6) to Rear Base Frame (A) and Support Frame (B).
- C. Insert Convex End Cap (5) into Support Frame (B).

RIGHT SIDE ASSEMBLY

Assemble the right side of the GDKR100 as described below.

- A. Connect Rear Base Frame (A) to Support Frame (B) using:
One 1 (M10x70 hex head bolt)
Two 4 (M10 washer)
One 3 (M10 nylon lock nut)
- B. Attach Rubber Pad (6) to Rear Base Frame (A) and Support Frame (B).
- C. Insert Convex End Cap (5) into Support Frame (B).

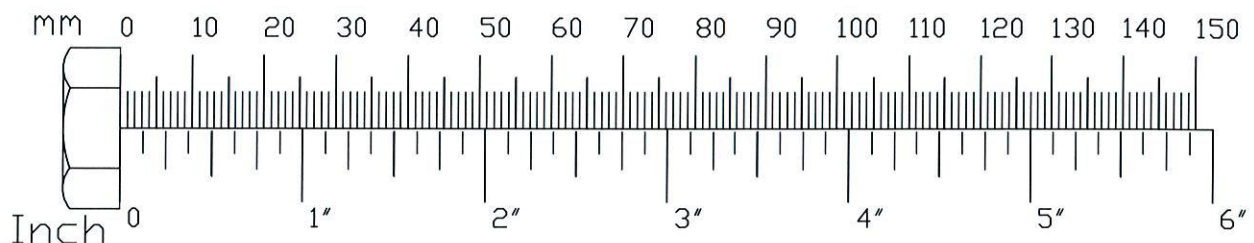

STEP

1

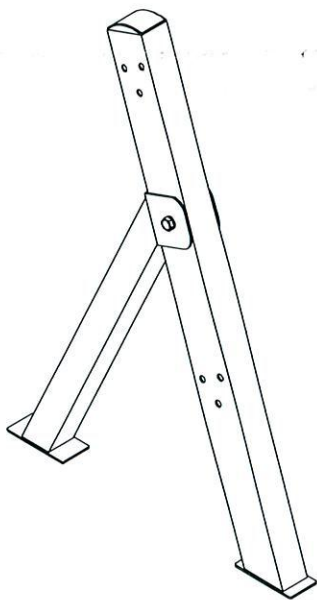

Above shows Step 1 assembled and completed.

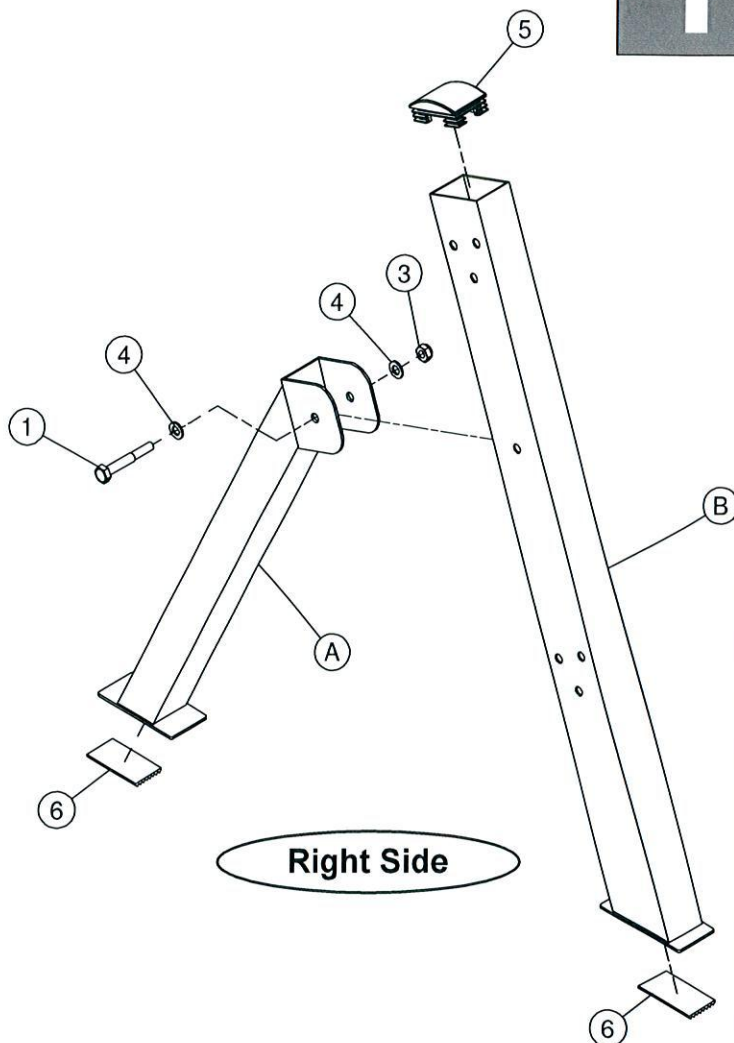

Right Side

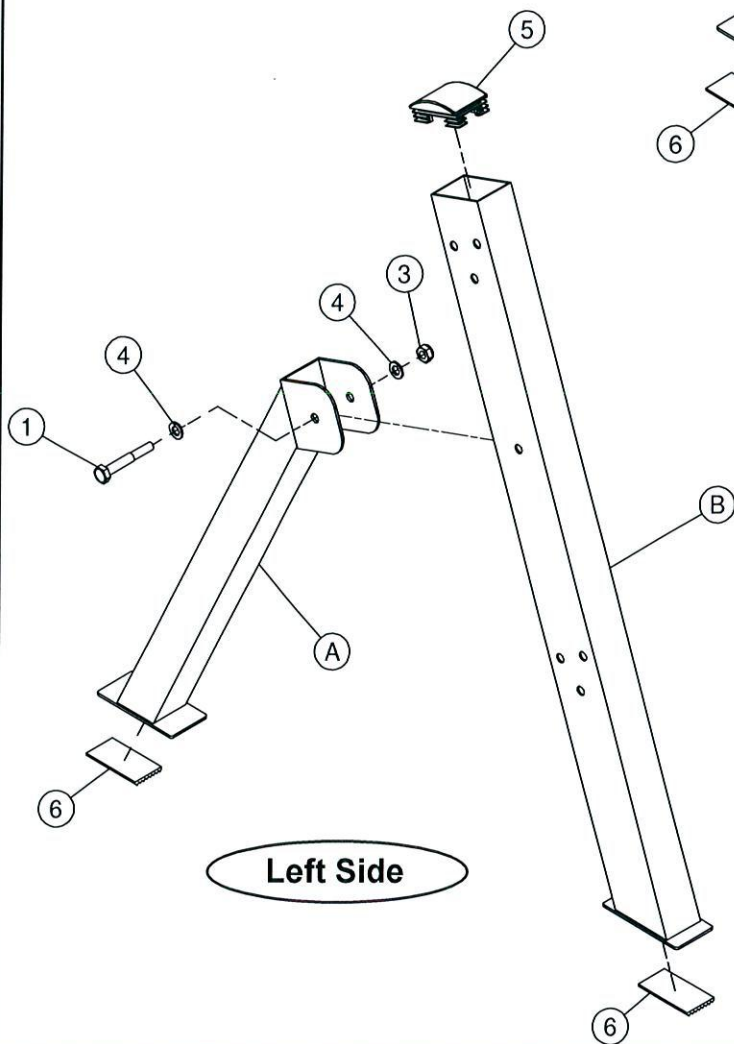

Left Side

STEP**2**

Be careful to assemble all components in the sequence they are presented.

KETTLEBELL RACK INSTALLATION

NOTE: The GDKR100 may be assembled as a Kettlebell Rack or a Dumbbell Rack. To install the GDKR100 as a Kettlebell Rack, use Step 2 of this manual. For Dumbbell Rack Installation, proceed to Step 3.

- A. Connect the lower Kettlebell Rack (C) and Plate (D) to Support Frame (B) on the left side using:
Two 2 (M10x75 hex head bolt)
Four 4 (M10 washer)
Two 3 (M10 nylon lock nut)
- B. Connect the upper Kettlebell Rack (C) and Plate (D) to Support Frame (B) on the left side using:
Two 2 (M10x75 hex head bolt)
Four 4 (M10 washer)
Two 3 (M10 nylon lock nut)
- C. Connect the lower Kettlebell Rack (C) and Plate (D) to Support Frame (B) on the right side using:
Two 2 (M10x75 hex head bolt)
Four 4 (M10 washer)
Two 3 (M10 nylon lock nut)
- D. Connect the upper Kettlebell Rack (C) and Plate (D) to Support Frame (B) on the right side using:
Two 2 (M10x75 hex head bolt)
Four 4 (M10 washer)
Two 3 (M10 nylon lock nut)
- E. Congratulations! The assembly of your GDKR100 Kettlebell Rack is complete.

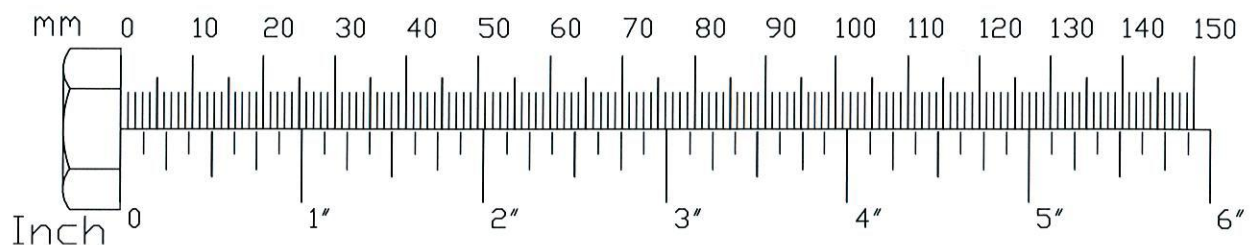

KETTLEBELL RACK INSTALLATION

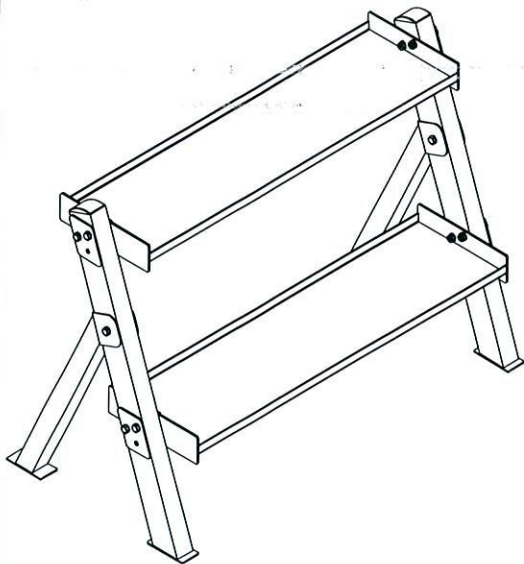

Above shows Step 2 assembled and completed.

Right Side

Left Side

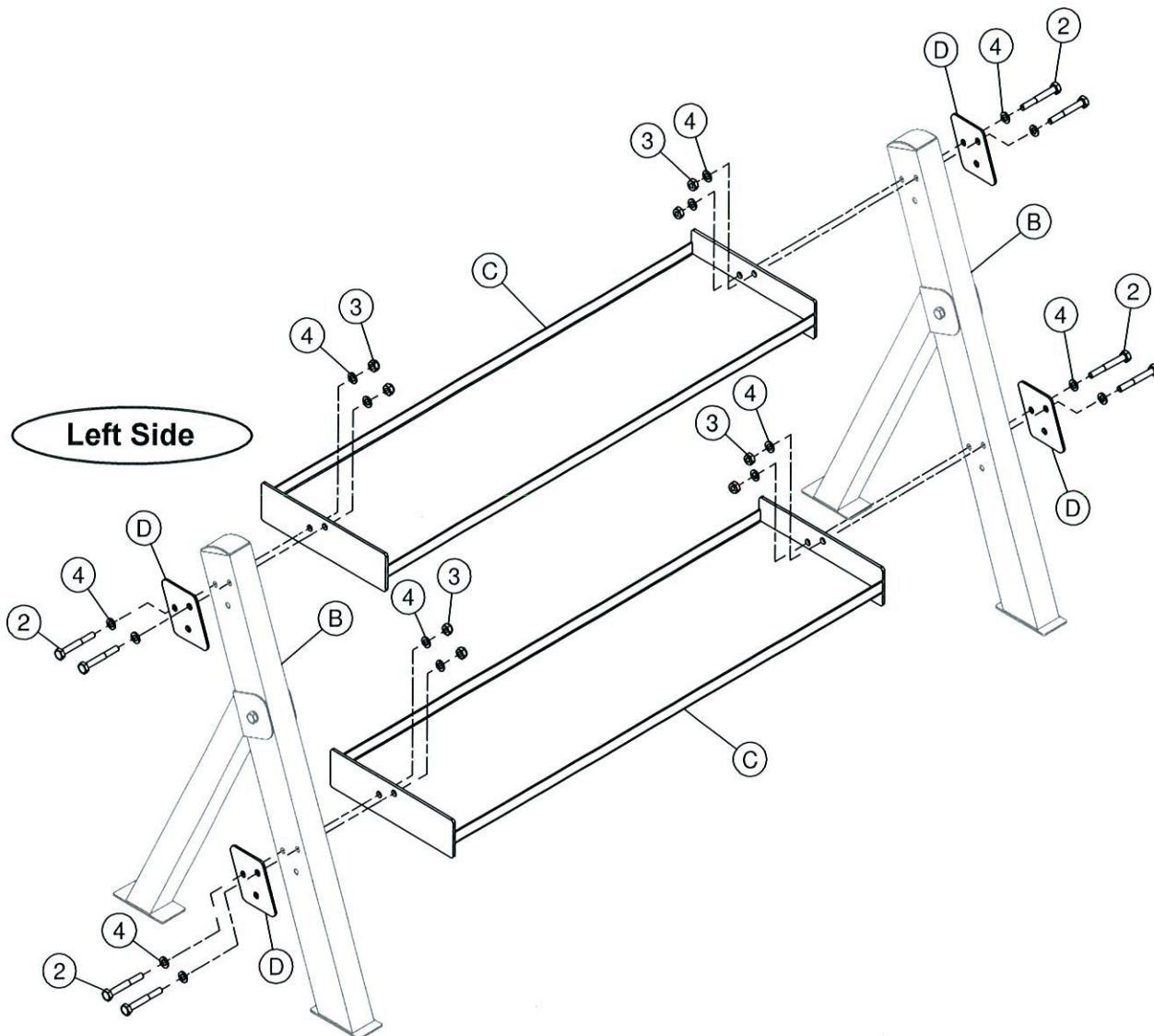

STEP**3**

Be careful to assemble all components in the sequence they are presented.

DUMBBELL RACK INSTALLATION

- A. Connect the lower Dumbbell Rack (C) and Plate (D) to Support Frame (B) on the left side using:
Two 2 (M10x75 hex head bolt)
Four 4 (M10 washer)
Two 3 (M10 nylon lock nut)
- B. Connect the upper Dumbbell Rack (C) and Plate (D) to Support Frame (B) on the left side using:
Two 2 (M10x75 hex head bolt)
Four 4 (M10 washer)
Two 3 (M10 nylon lock nut)
- C. Connect the lower Dumbbell Rack (C) and Plate (D) to Support Frame (B) on the right side using:
Two 2 (M10x75 hex head bolt)
Four 4 (M10 washer)
Two 3 (M10 nylon lock nut)
- D. Connect the upper Dumbbell Rack (C) and Plate (D) to Support Frame (B) on the right side using:
Two 2 (M10x75 hex head bolt)
Four 4 (M10 washer)
Two 3 (M10 nylon lock nut)
- E. Congratulations! The assembly of your GDKR100 Dumbbell Rack is complete.

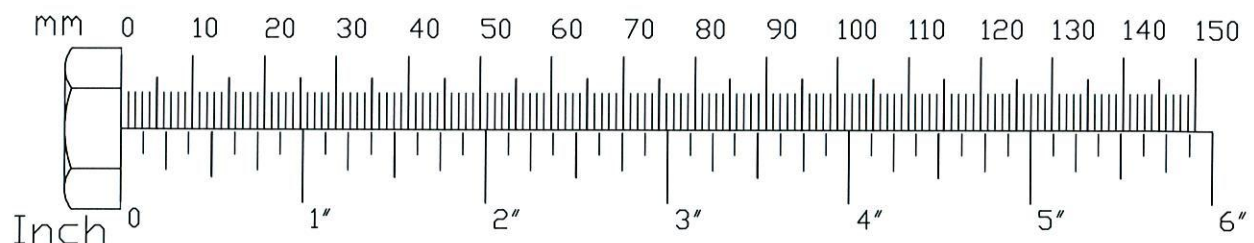

DUMBBELL RACK INSTALLATION

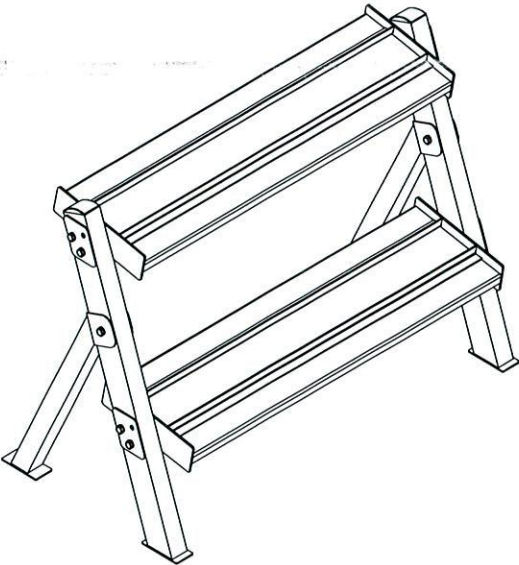

Above shows Step 3 assembled and completed.

Right Side

Left Side

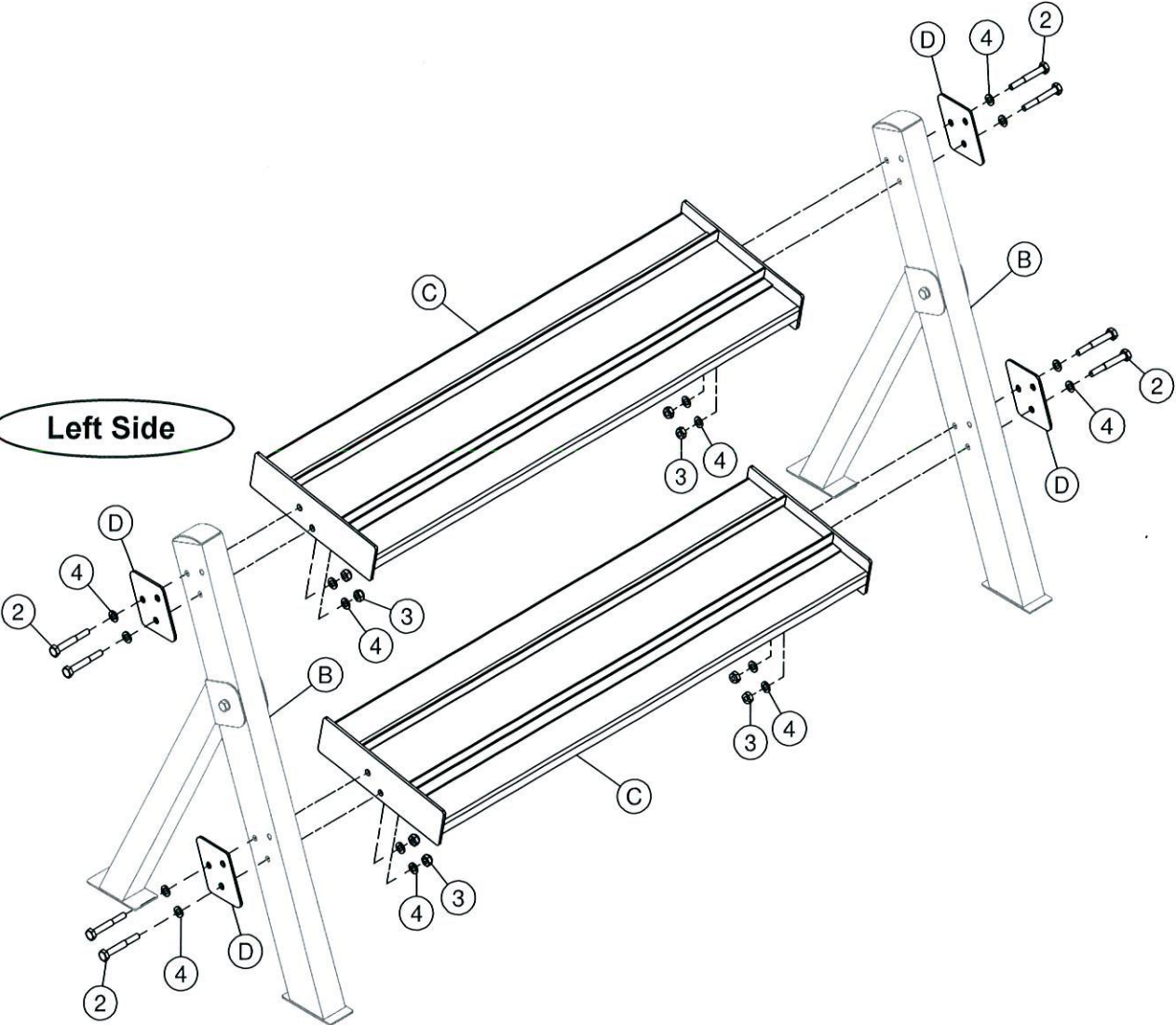

Mainframe Parts List

Part#	Qty	Description
A	2	REAR BASE FRAME
B	2	SUPPORT FRAME
C	2	DUMBBELL / KETTLE BELL RACK
D	4	PLATE 75mm x 121mm (8360-126)

Hardware List

1	2	HEX HEAD BOLT	M10x70	
2	8	HEX HEAD BOLT	M10x75	
3	10	NYLON LOCK NUT	M10	
4	20	WASHER	M10x19OD	
5	2	CONVEX END CAP	50mm x 75mm	(9211-084)
6	4	RUBBER PAD	38mm x 75mm	(9310-002)
7	1	BODYSOLID LOGO		(9440-027)
8	1	MAINTENANCE LABEL		(9440-103)
9	1	GENERAL WARNING STICKER		(9440-105)
10	1	BODYSOLID PLATE		(9440-199)

Part numbers are required when ordering parts.

Hardware (To Scale)

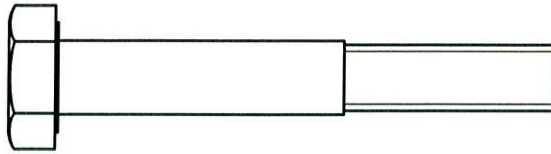

Part# 1

M10x70

Hex Head Bolt (Partial Thread)

Qty. 2



Part# 2

M10x75

Hex Head Bolt (Partial Thread)

Qty. 8



Part# 3

M10

Nylon Nut

Qty. 10

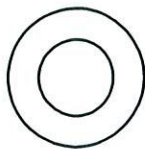

Part# 4

M10

Washer

Qty. 20

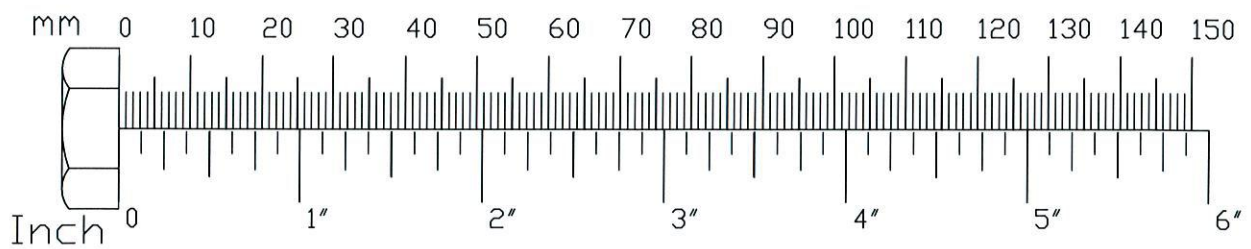

Kettlebell Rack Exploded View Diagram

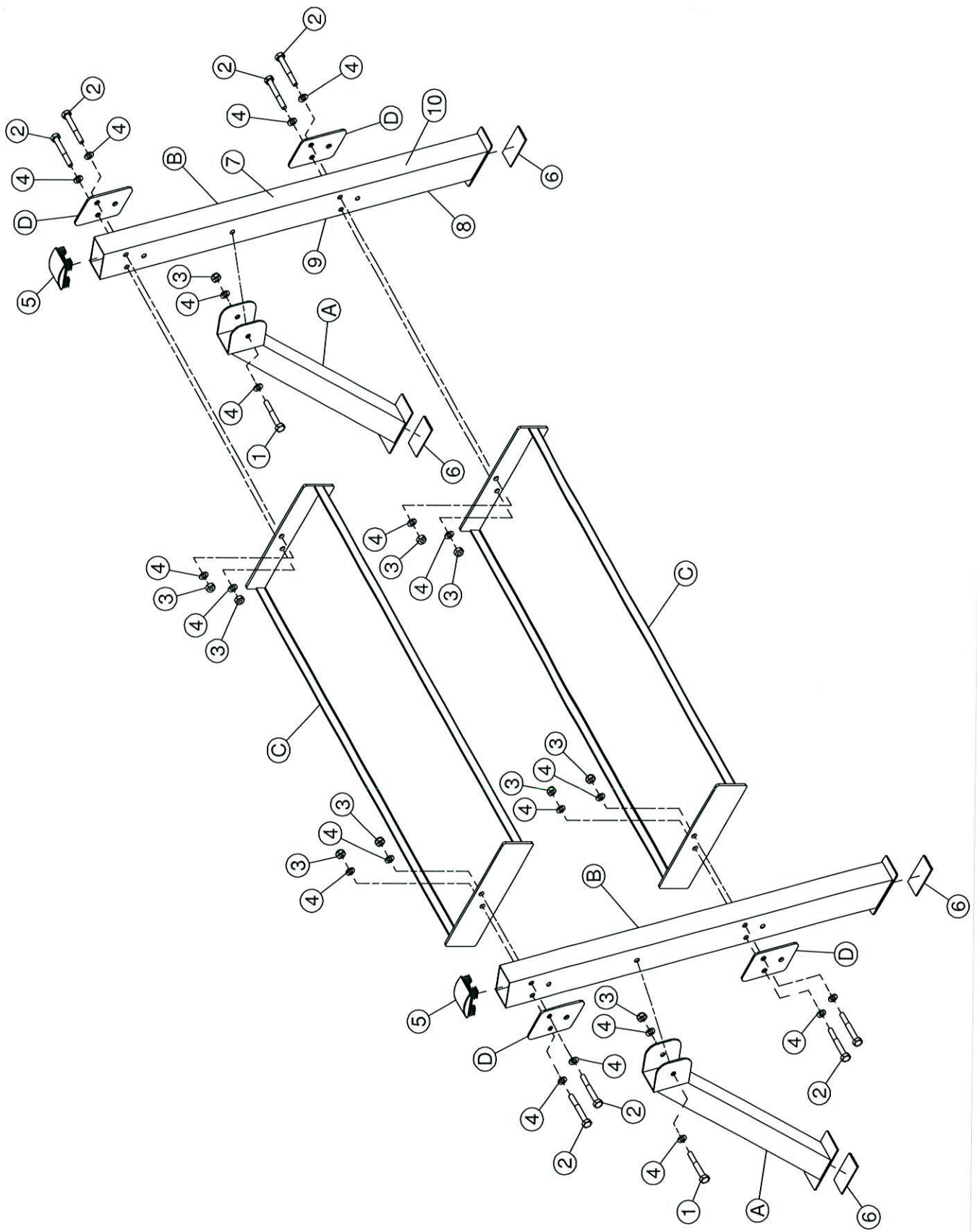

Dumbbell Rack Exploded View Diagram

