



INSTRUCTION MANUAL ITZ-TOYv2

Wireless CarPlay and Wireless Android Auto
for select Toyota vehicles



1 - Content



• V2 Interface



• Plug and Play Harness



• USB Harness



• WIFI Antenna

2 - Features, Compatibility

- Carplay wired and wireless
- Android auto wired and wireless
- Aftermarket front camera input
- Aftermarket reverse camera input
- USB Video Player
- Smartphone mirror (Android)
- Airplay (iPhone)
- Integrated with the OEM steering wheel controls

Power consumption	
Working wireless	500mA max
Working wired	2A max
Sleep	25mA max
USB output	1.5A max

Compatibility (only vehicles without 360 surround camera system):

- 2014-2019 Toyota Corolla (not compatible with 86140-02540 Fujitsu radio)
- 2014-2019 Toyota 4Runner (not compatible with Pioneer radio)
- 2016-2019 Toyota Prius (not compatible with Prius Prime 11.6" screen)
- 2017-2018 Toyota RAV4 (not compatible with 86100-42241)
- 2014-2019 Toyota Highlander
- 2016-2019 Toyota Prius C
- 2016-2017 Toyota Prius V
- 2015-2017 Toyota Sienna
- 2014-2019 Toyota Tacoma
- 2014-2018 Toyota Yaris
- 2016-2019 Toyota CH-R
- 2015-2018 Toyota Avalon
- 2014-2019 Toyota Sequoia
- 2014-2019 Toyota Tundra
- 2017-2019 Toyota GT86
- 2014-2019 Toyota Versa
- 2014-2017 Toyota Camry

4 - Dip Switch

For all vehicles, keep dip switches OFF.

1	2	3	4	5	6	7	8
KEEP OFF	KEEP OFF	KEEP OFF	KEEP OFF	KEEP OFF	KEEP OFF	KEEP OFF	KEEP OFF
ON if RVC is showing when not in reverse	OFF	OFF	OFF	OFF	OFF	OFF	OFF

5 - Install diagram

NOTE: your radio may look different, but these (3) connections will be the same.

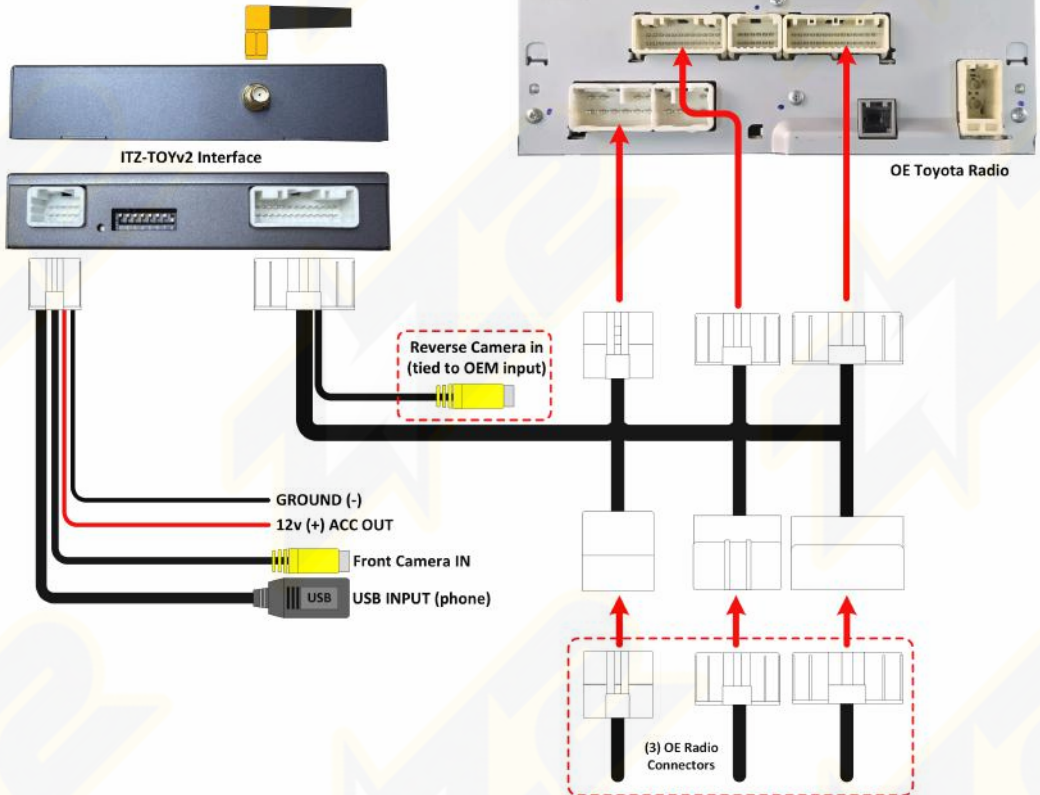

6 - How to setup Bluetooth / How to connect to Apple CarPlay

6.1 - Bluetooth setup

This unit is designed to be used independent from the OE radios Bluetooth system. Once installed, delete the phone from the radio and also delete the radio from the phone bluetooth connections list.

6.2 - CarPlay Connection

- If you would like to use a cable to connect your iPhone, please use a certified Apple cable.
- If you would like to use a wireless connectivity, please follow the next steps.
- Before pairing the iPhone with the system, please make sure you do a “hard reset” on the phone in order to prevent any malfunction. (Check phone manual/online)

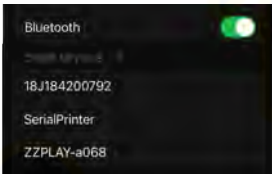

Once you are done with the previous step go to Settings > Bluetooth and the phone should be able to find a Bluetooth device called ZZPLAY-**** under the Other Devices.

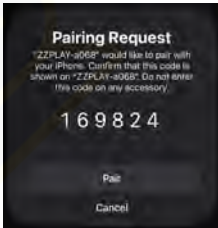

Select ZZPLAY-**** and a Bluetooth Pairing Request will be displayed on the screen with a code. Select “PAIR”.

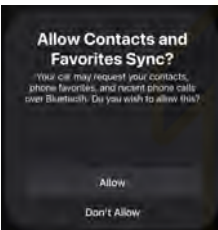

Right after the Pairing notification a new request to Sync your contact with the car will be displayed. Select “ALLOW” in order to have caller ID and access to your contacts through CarPlay.

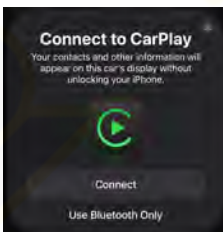

A notification asking for a permission to connect your iPhone to the car even when the phone is locked will pop up. Select “Use CarPlay” or “Connect” and the CarPlay main screen should show up on the factory radio screen.

7 - Operation

7.1 - Comm.



NOTE: Use 'AUX' source to access the interface at any time.

General Notes:

- Use AUX when using this interface, do not connect to OEM Toyota Bluetooth anymore whatsoever.
- A front camera can be added to this interface and can be viewed at any time via the SWC 'Mode' button, or can be setup to display after reverse gear (see next page setup menus)
- USB updates are performed via the provided USB (phone connection) if ever required (contact ZZ2)

7.2 - Interface menu

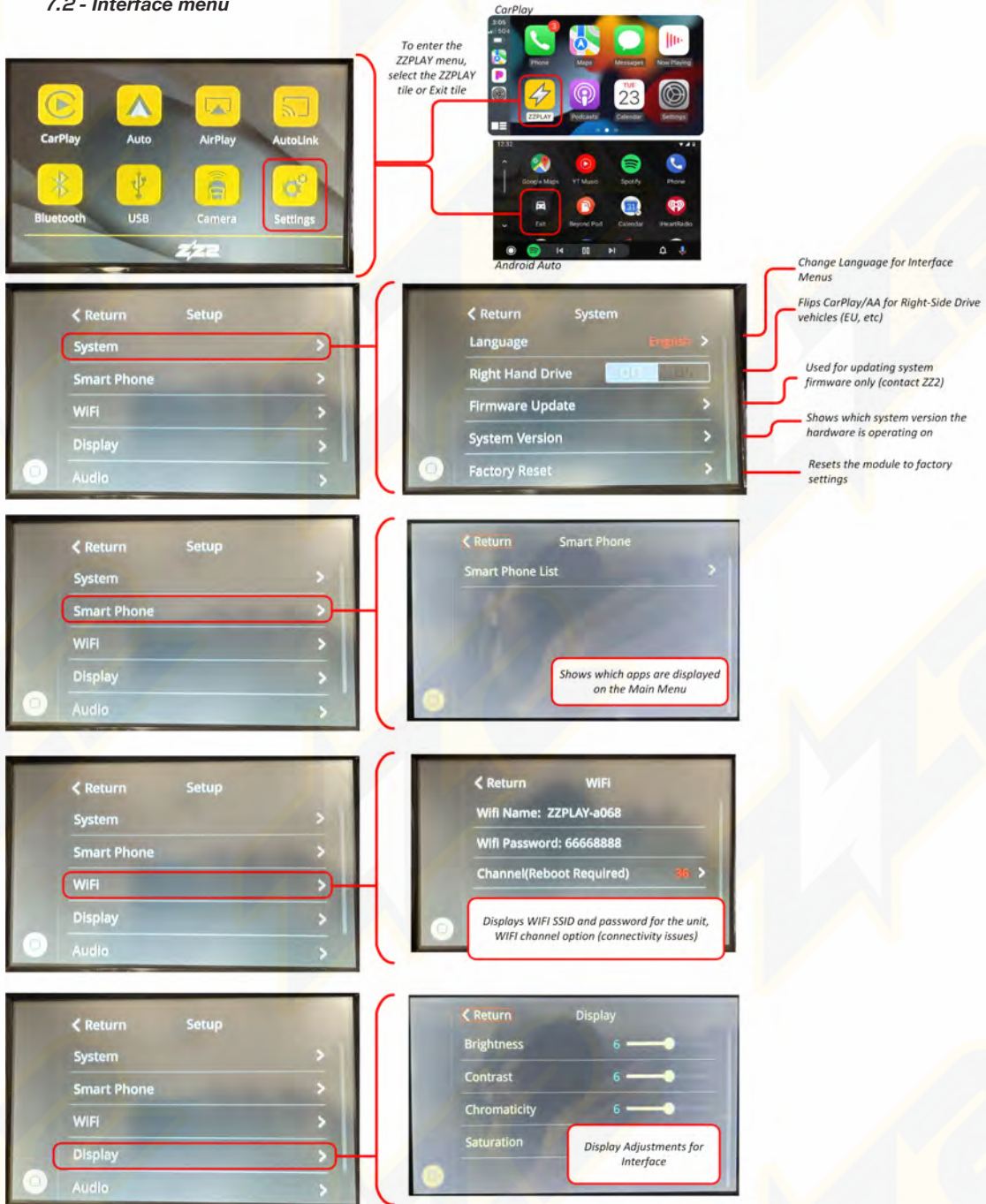

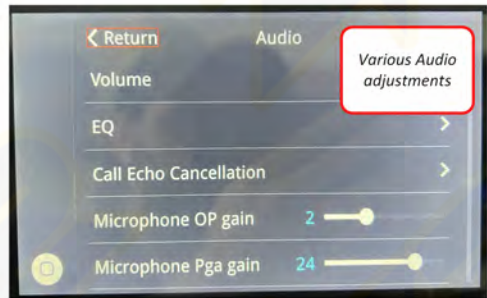
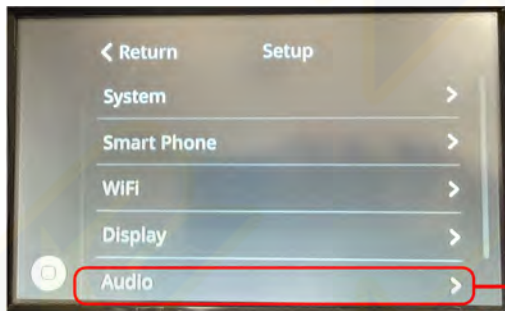

Flips the front camera image

Front camera timer: If adding a front camera, set this optional timer to show the front camera after leaving reverse gear

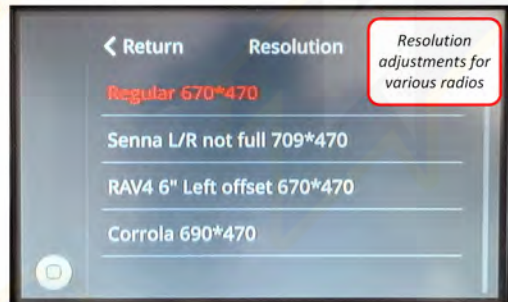

For Android Auto, leave this ON so the display will auto-change to night mode at night.



WARRANTY PROCEDURES



All of our products have 1-year-warranties. The following procedures must be conducted to ensure it's validity:



1 - Reach out to Tech Support

Get in touch with ZZ2 Tech Support through the phone or via Whatsapp, informing the invoice's code and the product's serial number and part code. In no hypothesis will the piece be replaced without previous contact with Tech Support.



2 - Technical Report

ZZ2 Tech Support must verify the problem as an equipment malfunction. The piece will not be replaced should the problem be caused by misuse, misinstallation or occasional falls caused to the product.



3 - Replacement

The new interface will be replaced via mail upon return of the malfunctioning product.



4 - Forward Replacement

In case the piece requires an urgent replacement, an invoice with the product's retail price will be emitted, being valid for 28 days following its emission. Upon the return of the malfunctioning hardware, the invoice will be automatically cancelled, otherwise it must be paid normally.





877-241-2526

www.zz-2.com
info@zz-2.com