

ITZ-LRB



ZZPLAY

Advanced CarPlay/Android Auto integration for '12-'16 Land Rovers equipped with BOSCH radio system

Components



ZZPlay Interface

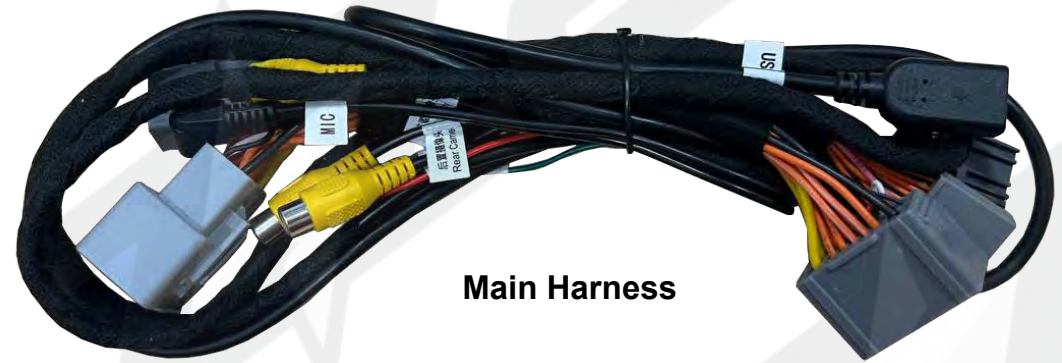

Main Harness



GVIF Y-Cable



Velcro sheet



SMB Antenna

ITZ-LRB Installation Diagram



Notes:

- The radio must be in BT Audio or AUX mode in order for audio playback through the OE speakers. *NOTE: some vehicles, AUX is located under 'My Music' and require no connection to the USB.*
- If using (violet) reverse wire trigger, '12v ACTIVE' must be set under 'Reverse Detect' in the 'Car Settings' menu.
- When this kit is installed, factory Navigation will be inoperable (if equipped).
- An aftermarket camera cannot be added to this kit currently.

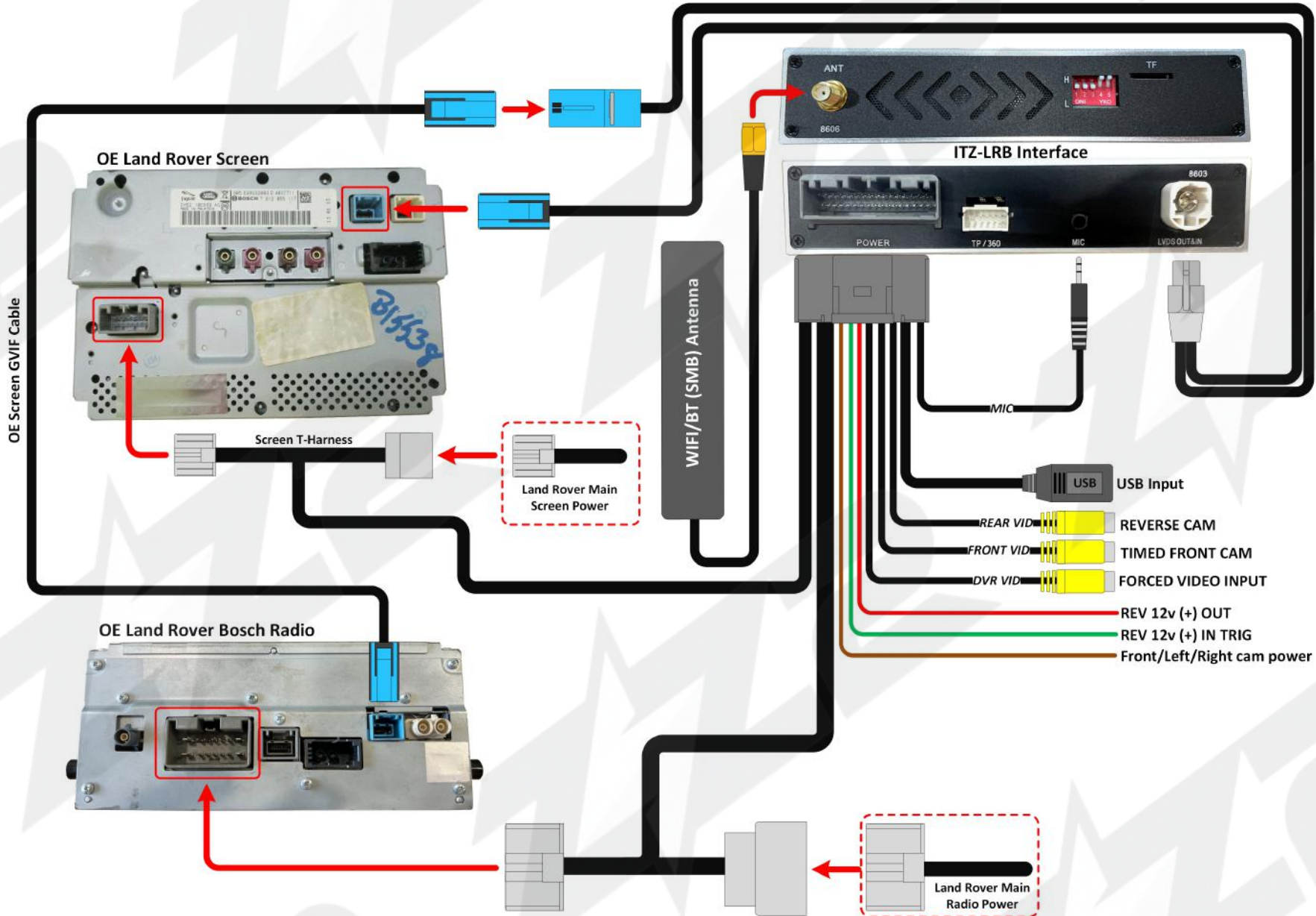

DIP Switch Settings

For this system, when you make a dip switch change, you **MUST** first remove the SCREEN T-HARNES plug from the CAR SIDE. The screen and the ZZPLAY unit must boot at the same time.

1. Turn vehicle OFF
2. Unplug screen T-HARNES from CAR side
3. Adjust dip switch as necessary
4. Reconnect T-HARNES from CAR side
5. Turn vehicle ON and test.

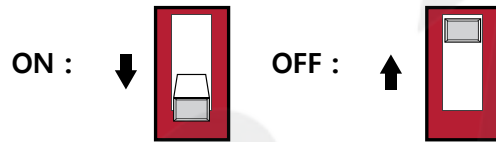

1	2	3	4	5	Vehicle/INFO
OFF	OFF	OFF	OFF	OFF	Typical Setting
ON	OFF	OFF	ON	OFF	Discovery / LR4
OFF	ON	OFF	ON	OFF	JAGUAR
OFF	OFF	OFF	ON	OFF	Harman Style
OFF	OFF	OFF	OFF	ON	European Style



• How to connect to Apple CarPlay / How to setup Bluetooth Phone Calls



1. If you would like to use a cable to connect your iPhone, please use a certified Apple cable.
2. If you would like to use a wireless connectivity, please follow the next steps.
3. Before pairing the iPhone with the system, please make sure you do a "hard reset" on the phone in order to prevent any malfunction. (Check phone manual/online)
4. Once you are done with the previous step go to Settings > Bluetooth and the phone should be able to find a Bluetooth device called ZZPLAY***** under the Other Devices.



4. Select ZZPLAY***** and a Bluetooth Pairing Request will be displayed on the screen with a code. Select "PAIR".

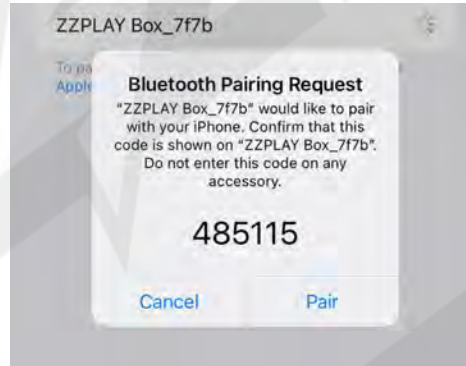

5. Right after the Pairing notification a new request to Sync your contact with the car will be displayed. Select "ALLOW" in order to have caller ID and access to your contacts through CarPlay.

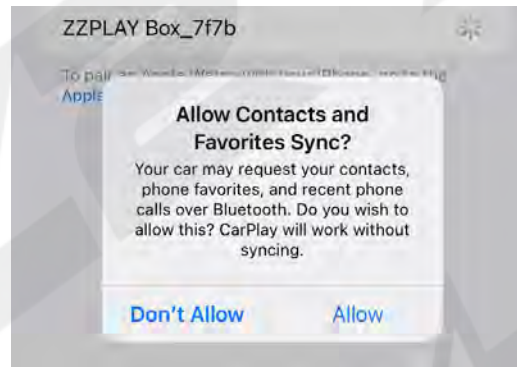

6. A notification asking for a permission to connect your iPhone to the car even when the phone is locked will pop up. Select "Use CarPlay" and the CarPlay main screen should show up on the factory radio screen.

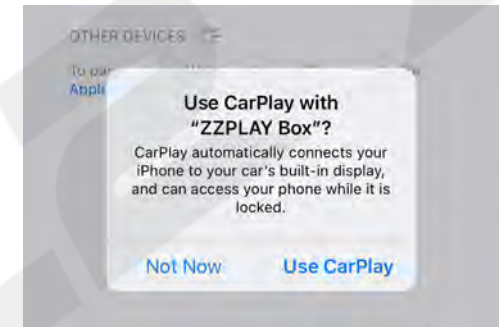

7. When the phone is connected and paired properly, the screen will automatically switch to CarPlay. Once you are in CarPlay mode, if ever necessary, select the ZZ2 app to go to the *interface's* main menu.

Controlling the module



MAIN MENU
button (CarPlay)

Press & HOLD to Enter or
Exit CarPlay mode



Pickup Phone
Call / SIRI wake



HOLD to Activate SIRI

ATTENTION: With at least system software (2023-12-05), use OEM Bluetooth streaming (source) for all audio playback from CarPlay/Android Auto.



AUDIO Setup for CarPlay & Android Auto

The best way to use this system is to use factory Land Rover or Jaguar Bluetooth audio for your sound source instead of AUX input. Be sure to be connected to factory Land Rover or Jaguar Bluetooth Audio (source) with the phone, and turn ON the following setting inside the ZZPLAY menu:

1. Either disconnect any phone, or find the 'ZZPLAY' tile (CarPlay) or 'Exit' tile (Android Auto). Scroll all the way right and enter 'Settings'.
2. Once in Settings, Go to 'System', then choose 'Factory Mode'.



3. Once in Factory Mode, choose 'Phone Link setting'.

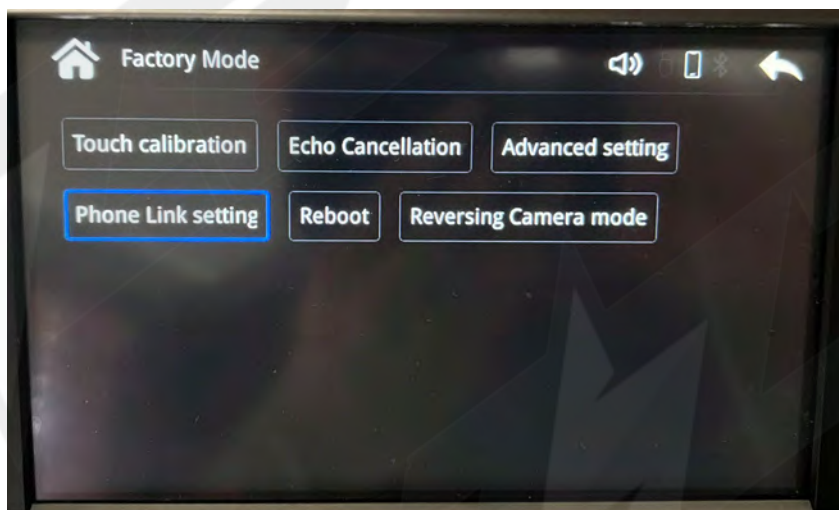

4. Now check ON 'Disable phone link audio'. After this, return to 'Factory Mode' (one step back) and choose 'Reboot'. Use the factory Bluetooth Audio source for all sound (music & phone calls).



ZZPLAY Interface Main Menu

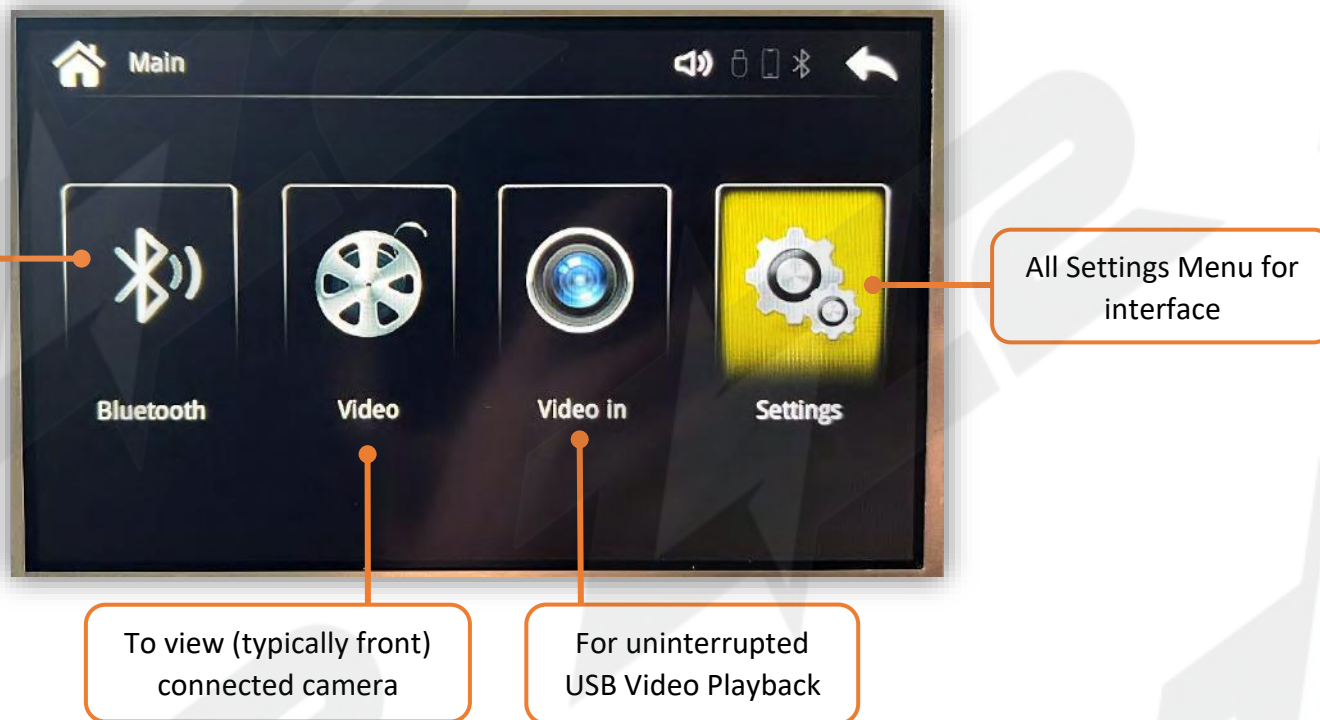
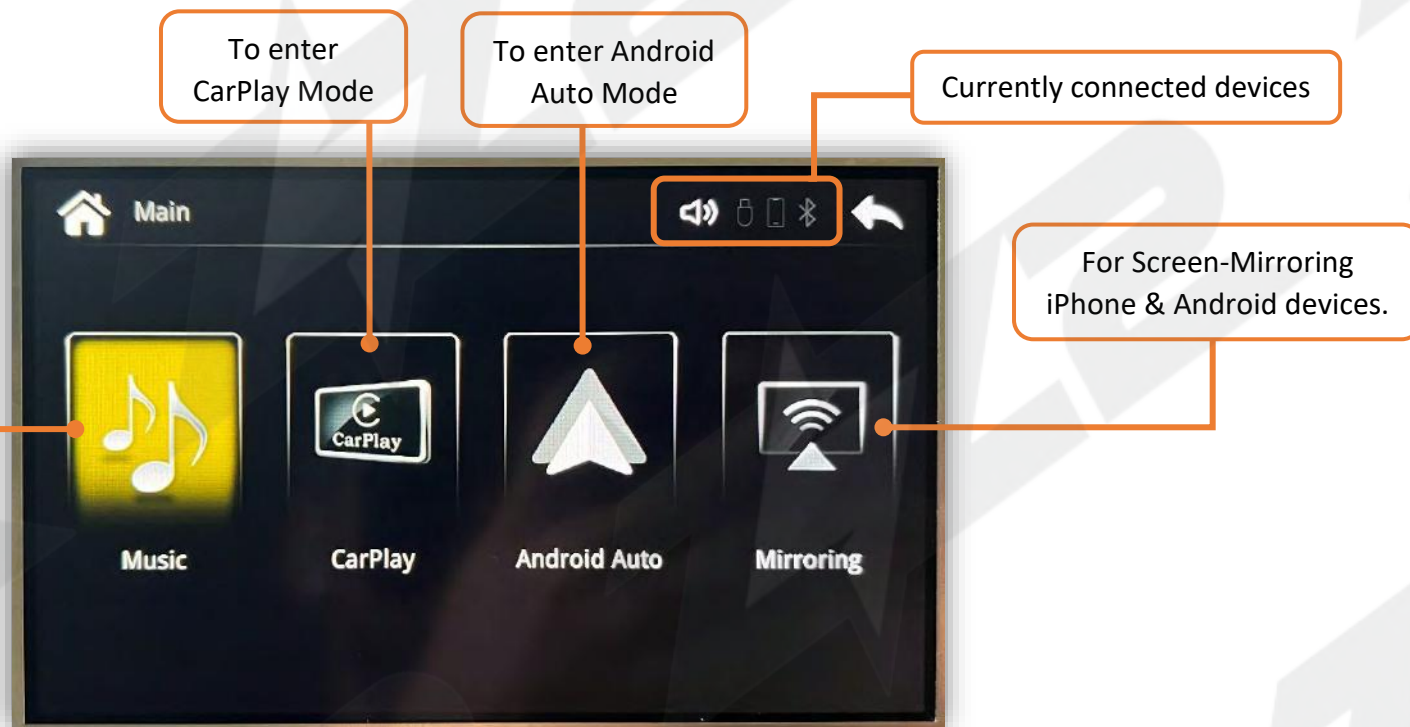

ZZPLAY Interface Settings Menu



The next few pages overview the ZZPLAY interface, navigating settings and explains entering/exiting all menus. There are (2) menu systems that exist outside of the OE radio system: Carplay (or Android Auto) menu and the ZZPLAY Interface Menu. They operate independent of each other (the ZZPLAY Interface menu will function regardless of whether or not a phone is connected to the module). Settings found inside Carplay will only affect CarPlay functionality. Settings for the ZZPLAY Interface control things like reverse camera settings, audio output control settings and other vehicle/interface-specific parameters.

Selecting 'Settings' will bring you to the ZZPLAY Interface Setup Menu with all options pertaining to the specific vehicle and install.

CARPLAY

ZZPLAY INTERFACE MENU

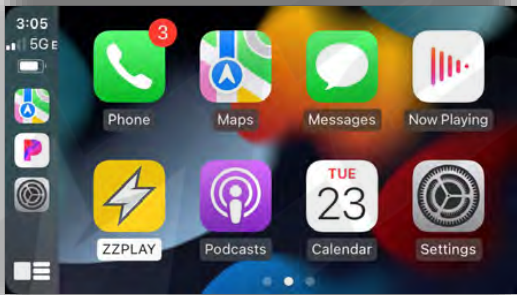

To enter the ZZPLAY Interface Menu from the CARPLAY system, locate the **ZZPLAY** tile and select it. If there is no phone connected, simply using the activation button (which normally brings you into CARPLAY mode) will enter you in the ZZPLAY Interface Menu.



General:

Allows adjustments for global volume control and navigation (specific) volume control output. Also there is an option for auto-pairing the user's handset.



Car Setting:

Allows adjustments for camera(s) and MIC options. **These options are specific to the how the interface handles camera triggers and types (data vs analog wire, OEM vs aftermarket etc).** A few other vehicle-specific settings can be found here as well.

ZZPLAY Interface Settings Menu



Display:

Allows adjustments for brightness, contrast & saturation



Sound:

Allows bass, mid & treble adjustments for audio output.



System:

Shows hardware & Software information.

Factory Mode:

Echo Cancellation: Run this to get the best possible performance out of the provided microphone (if equipped)

Advanced Setting: Stores settings that do not need adjustment at this time from end user.

Phone Link Setting: Use these settings if you want a specific type of handset (iPhone vs Android) to be wired only / or wireless only. Helpful for when 2 handsets are in the vehicle at the same time.

Reboot: press to reboot the ZZPLAY system without turning vehicle off.

Reversing Camera Mode: typically does not need adjustment, but adjusts video standard for connected cameras.

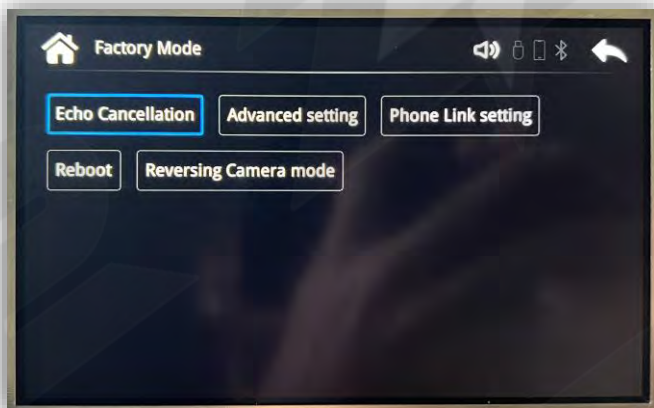

Phone Link Setting

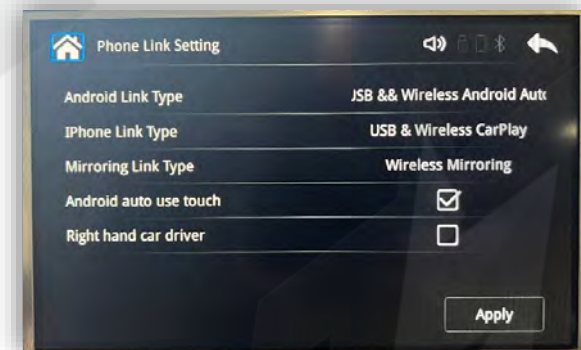



Question: *I can't hear any audio from the CarPlay/Android Auto system.*

Answer: With the latest software, you must use factory Bluetooth Streaming in order to hear any sound from the ZZPLAY kit. This includes during phone calls. NOTE: The phone must be connected to the factory radio Bluetooth simultaneously with the ZZPLAY module, and you must rest on 'BT Audio'.

Question: *I'm hearing reports of a lot of echo or delayed echo on audio during a phone call. Why is this happening and how can I eliminate this?*

Answer: This happens when using OEM AUX input for audio instead of OEM Bluetooth. The AUX path travels through the OEM amplifier, where there is active time-alignment & processing on this audio channel.

Question: *Sometimes my phone won't connect lately / Sometimes when it connects the screen goes black / Sometimes CarPlay kicks me out back to the interface menu.*

Answer: For iPhone users, you must perform a 'Hard Reset' on the phone in use on average twice a month to clear certain cache and reset the processors (this will not wipe any data). Google search 'Hard Reset iPhone 13' (or whatever version iPhone version you have) and perform that task. After this is done, you will see a difference in speed and reliability (of pairing/connecting).

Question: *Incoming text responses from SIRI are silent on CarPlay. It mutes the audio but I don't hear the read-out.*

Answer: This often happens for 2 reasons: The iPhone needs a hard-reset (see previous question), or the phone is connected to the vehicle's OE Bluetooth for both **phone calls & audio (and the text read-outs are being sent to the vehicle BT source - you're on AUX source)**. You want to be connected to the vehicle for **phone calls ONLY** - for iPhone the only way to make this distinction is to adjust the phone setup on the OE radio side. Find your phone (name) in the Bluetooth or Phone setup in the OEM radio settings and disconnect as an audio player. NOTE: *not all vehicles have this option, but it seems to happen mostly with cars that do have this option (Lexus, etc).*

Question: *Using Android, I cannot get the phone to reliably connect wirelessly (or at all).*

Answer: Android phones are more finicky and iPhones with their wireless connectivity. Make sure the OS is fully up-to-date. Clear the cache on the Android Auto application. The Android OS must be at least version 11. Some phones (TCL, Motorola) seem to have protocols that don't play nice with every system. If you run into this, use a good USB-C cable for the Android Auto Connection instead.

OE System Note



After installation is completed, verify that 'Time out home' is turned OFF, otherwise the OE screen will time out due to (perceived) inactivity, resulting in a drop-out situation from CarPlay/AA.

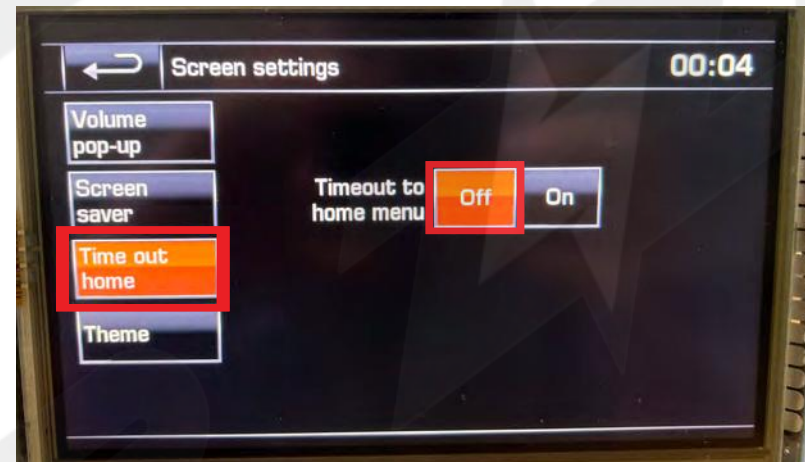
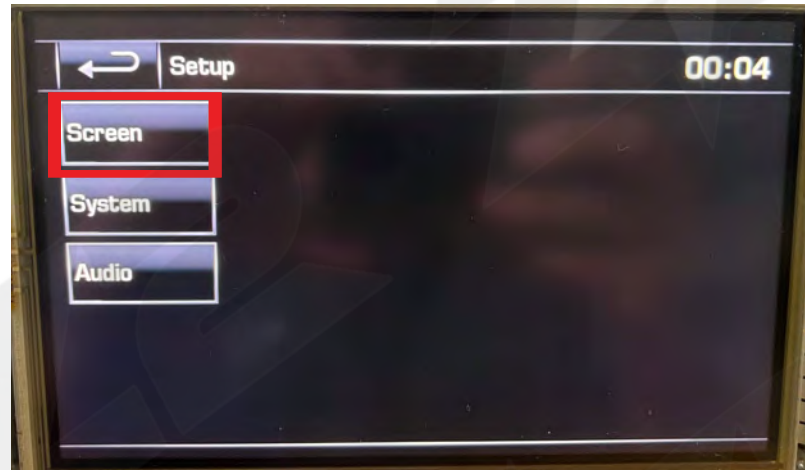



support@zz-2.com

929-220-1212

Toll free: 877-241-2526

Extension 2: Tech Support

Agreement: End user agrees to use this product in compliance with all State and Federal laws. ZZDOIS LLC dba ZZ-2 is not to be held liable for misuse of its product. If you do not agree, please discontinue use immediately and return product to retailer. This product is intended for off-road use and passenger entertainment only.

Before installation of any ZZ-2 LLC products, users must fully read and understand the manual. By installing and/or using the product you agree to be bound by the following terms and conditions: *In no respect shall ZZ-2 LLC incur any liability for any damages, including, but limited to, direct, indirect, special, or consequential damages arising out of, resulting from, or any way connected to the use of ZZ-2 LLC products whether or not based upon warranty, contract, tort, or otherwise; whether or not injury was sustained by persons or property or otherwise; and whether or not loss was sustained from, or arose out of, the results of, the item, or any services that may be provided by ZZ-2 LLC.*