

Mofi

ELECTRONICS

Thank you for purchasing the MasterPhono Preamplifier

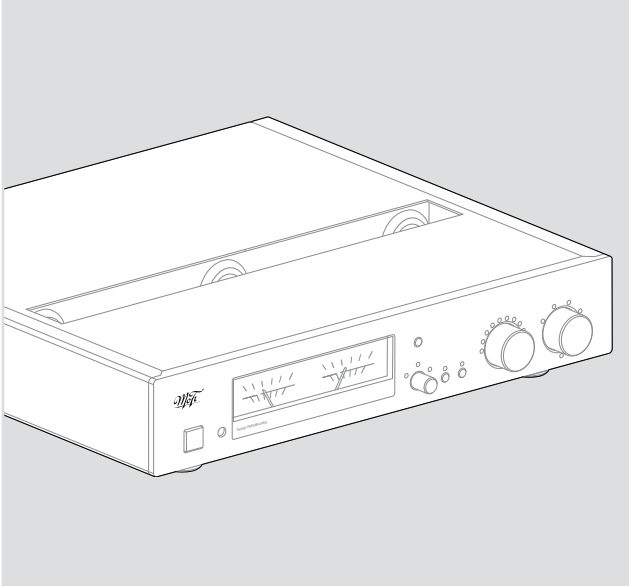

MasterPhono is designed to extract the maximum amount of information from your turntable, tonearm, and cartridge - and get you as close as possible to the sound Mobile Fidelity Sound Lab mastering engineers achieve in the studio. To accomplish these goals, I leveraged four decades of hands-on experience in the areas of low-noise, small-signal analog amplification, power supply optimization, and passive filtering. When combined with top-tier playback equipment, MasterPhono proves remarkably faithful to the original source — especially if you utilize the current-mode (transimpedance) input with an appropriate phono cartridge.

Visually, the inclusion of meters on MasterPhono harkens back to our studio heritage. Though fun to watch as output monitors, they have several built-in features that are useful in optimizing your phono cartridge's alignment.

Please read through this manual to become familiar with MasterPhono's various features. For additional information, please visit our website.

Happy listening,

Peter Madnick
Lead Designer, Audio Products, MoFi Electronics

Important Safety Instructions

⚠ The lightning flash with the arrowhead symbol within an equilateral triangle is intended to alert you to the presence of “dangerous voltage” inside the product that may constitute a risk of electric shock.

⚠ The exclamation point within the equilateral triangle is intended to alert you to the presence of important operating and maintenance instructions in the literature accompanying the product. **TO REDUCE THE RISK OF ELECTRIC SHOCK, DO NOT REMOVE THE COVER. NO USER-SERVICEABLE PARTS ARE INSIDE. REFER SERVICING TO QUALIFIED PERSONNEL.**

1. Read instructions: Read all the safety and operating instructions before operating this product.
2. Retain instructions: Retain safety and operating instructions for future reference.
3. Heed warnings: Adhere to all warnings on the product and in the operating instructions.
4. Follow instructions: Follow all operating and use instructions.
5. Cleaning: Unplug this product from the wall outlet before cleaning. Use a damp cloth for cleaning. Clean the outside of the product only.
6. Attachments: Do not use attachments that are not recommended by the product manufacturer; they may be hazardous.
7. Water and moisture: Do not use this product near water.
8. Accessories: Do not place this product on an unstable cart or stand. The product may fall, causing bodily injury and damage. Any product and cart combination should be moved with care. Quick stops, excessive force, and uneven surfaces may cause the product and cart to overturn.
9. Ventilation: Slots and openings in the product’s cabinet provide ventilation to ensure reliable operation of the product and to protect it from overheating. These openings must not be blocked or covered. This product should not be placed in a built-in installation such as a bookcase or rack unless proper ventilation is provided.
10. Power sources: Operate this product only from the type of power source indicated on the label. If you are unsure of the type of power supply to your home, consult your dealer or local power company. This product is equipped with a three-prong grounding plug. This plug will only fit into a grounded power outlet. If you are unable to insert the plug into the outlet, contact your electrician to replace your obsolete outlet. Do not defeat the safety purpose of the grounding plug.

11. Power-cord protection: Power-supply cords should be routed so that they are not likely to be walked on or pinched by items placed on or against them.

12. Lightning: Unplug the unit from the wall outlet for added protection during a lightning storm, or when it is left unattended and unused for long periods of time. This will prevent damage to the product due to lightning and power line surges.

13. Overloading: Do not overload wall outlets or extension cords. This can result in a fire or electric shock.

14. Inserting objects into unit: Never push objects of any kind into this product through any openings; they may touch dangerous voltage points or short-out parts that could result in fire or electric shock.

15. Servicing: Do not attempt to repair or service this product yourself. Opening or removing covers may expose you to dangerous voltage and other hazards. Refer all servicing to qualified service personnel.

16. Damage requiring service: Unplug this product from the wall outlet and refer servicing to qualified service personnel under the following conditions:

A) If the power-supply cord or plug is damaged.

B) If liquid has been spilled into the product.

C) If the product has been exposed to rain or water.

D) If the product does not operate normally by following the operating instructions.

E) If the product has been dropped or damaged in any way.

F) If the product exhibits a distinct change in performance.

17. Replacement parts: When replacement parts are required, be sure the service technician uses replacement parts specified by the manufacturer. Unauthorized substitutions may result in fire, electric shock, and other hazards.

18. Safety check: Upon completion of any service or repairs to this product, ask the service technician to perform safety checks to determine that the product is in proper operating condition.

19. Wall or ceiling mounting: Mount the product to a wall or ceiling only as recommended.

20. Heat: The product should be situated away from heat sources such as radiators, heat registers, stoves, and other products (including amplifiers) that produce heat.

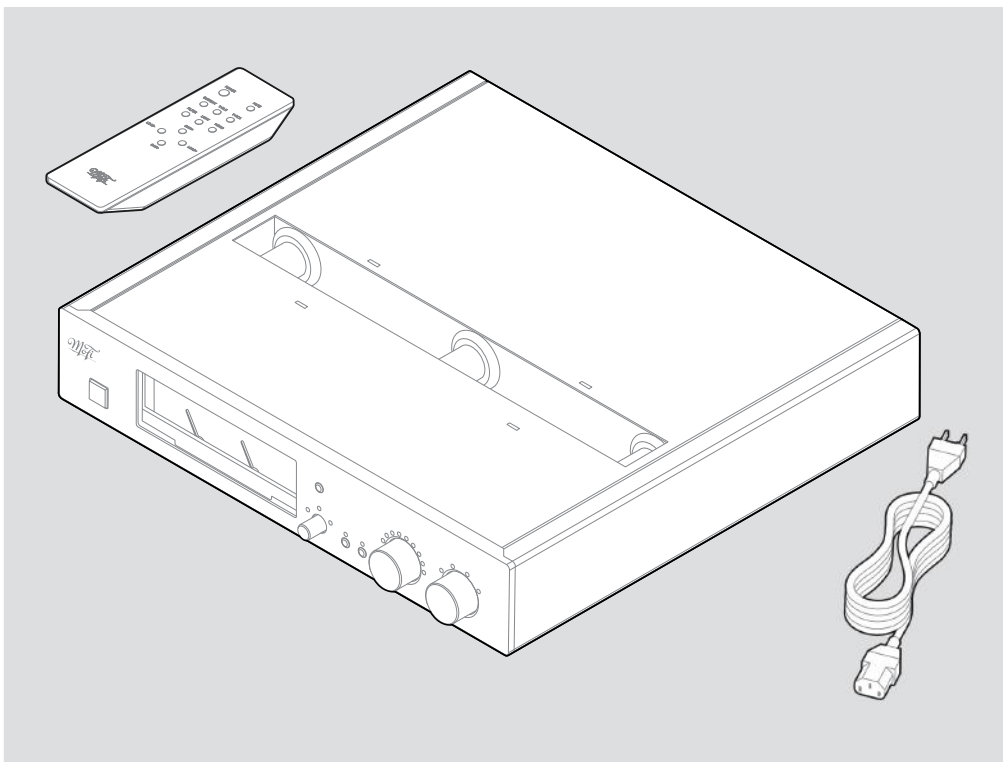

In the Box

1. Phono preamplifier
2. Remote control
3. Power cord

INSTALLATION

▲ Check all connections before you plug in the power cord or turn on the main system.

MasterPhono will operate at its best when properly installed in a location free from magnetic fields such as those generated by equipment with power transformers (for example, an amplifier), and within a reasonable distance of your turntable and other audio component(s).

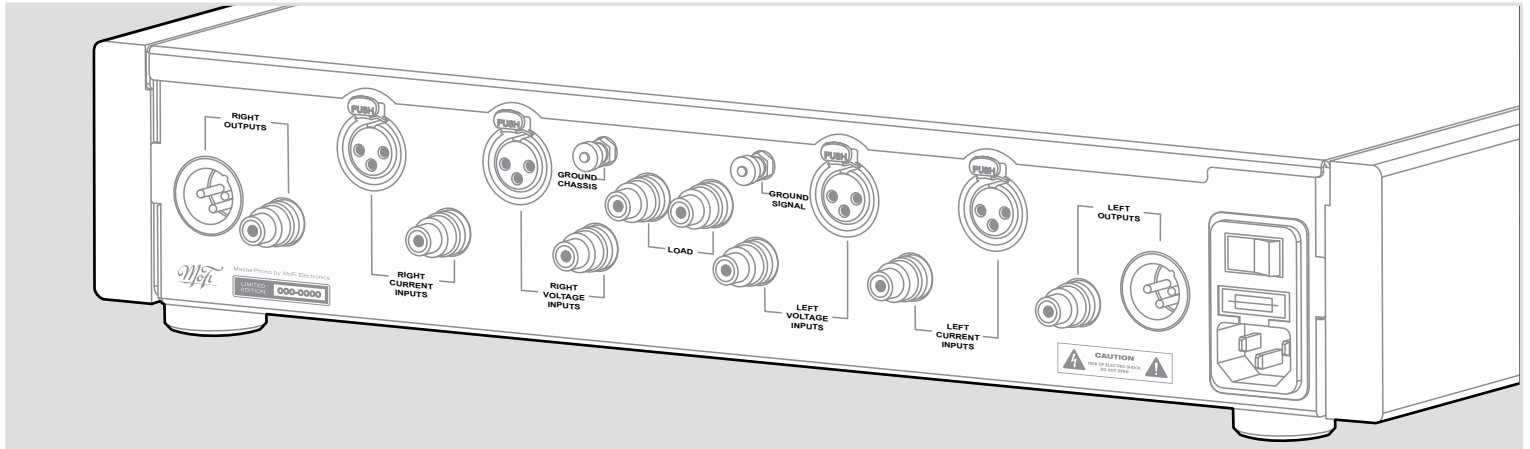
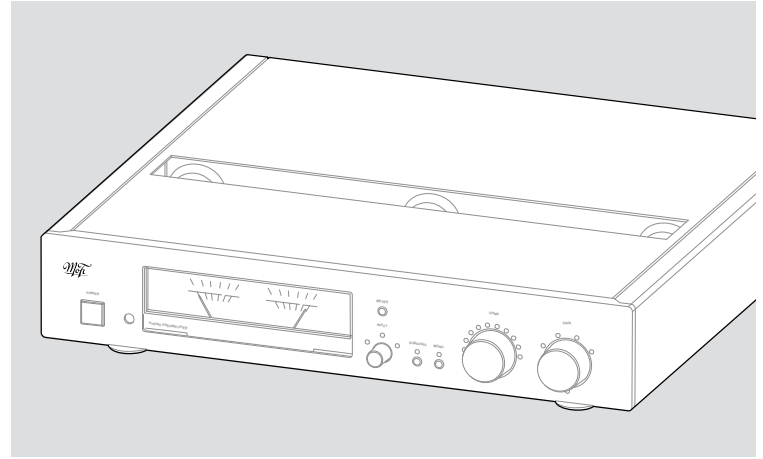

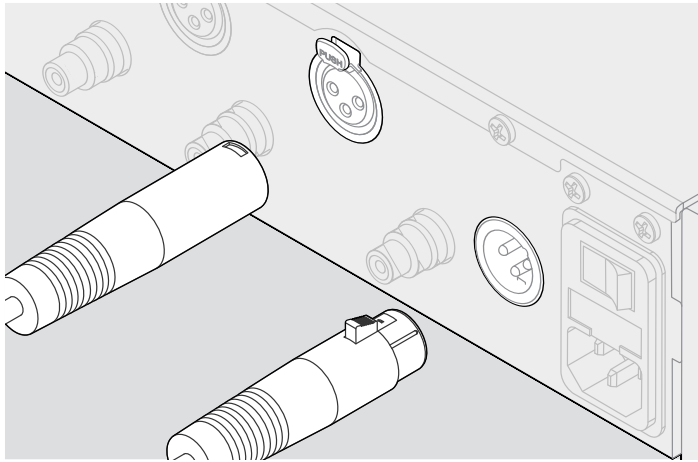

Connecting Inputs, Outputs, and Ground

XLRs are recommended for optimal performance.

Connect the MasterPhono outputs to your preamp inputs.

Connect your turntable's output to a MasterPhono input as recommended (see below).

Designed for use with low-impedance or current-source phono cartridges, Input 1 bypasses and turns off the Ohms selector and LEDs. Do not use the XLR and RCA at the same time on this input.

Inputs 2 and 3 are voltage inputs for use with moving coil (MC), moving iron (MI), and moving magnet (MM) cartridges.

The Load RCA jacks are designed to be used with optional custom RCA load resistors.

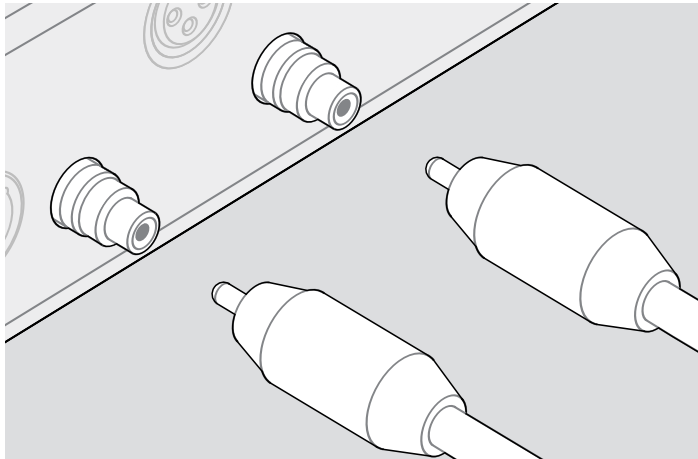

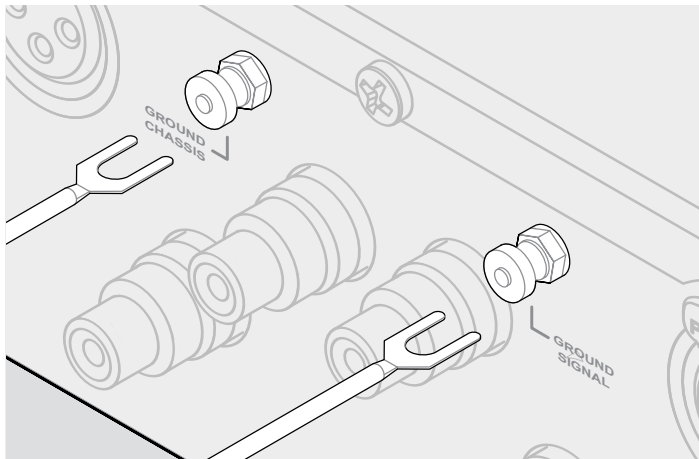

Ground and Power Cord

▲ To protect your system, make sure the volume of your main system is turned down.

Chassis Ground: Used to ground turntables with single ground or to ground the motor board or plinth on turntables with multiple grounds.

Signal Ground: Used to ground a turntable's arm.

Note: Some systems might have lower hum with a different arrangement, experiment until you achieve the best result.

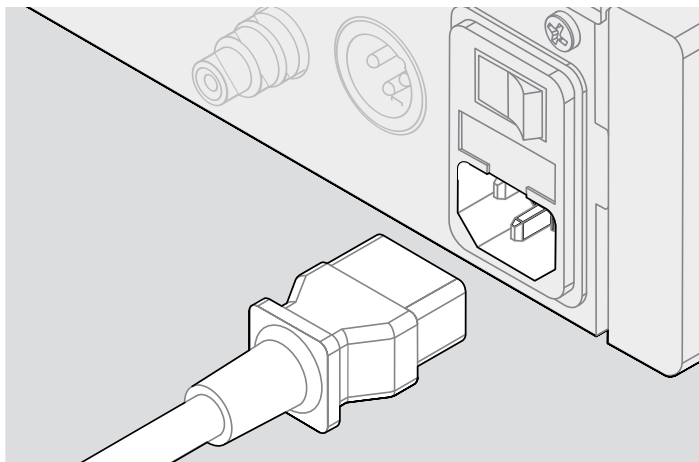

Connect the power cord from the MasterPhono mains input to your power conditioner or main's outlet.

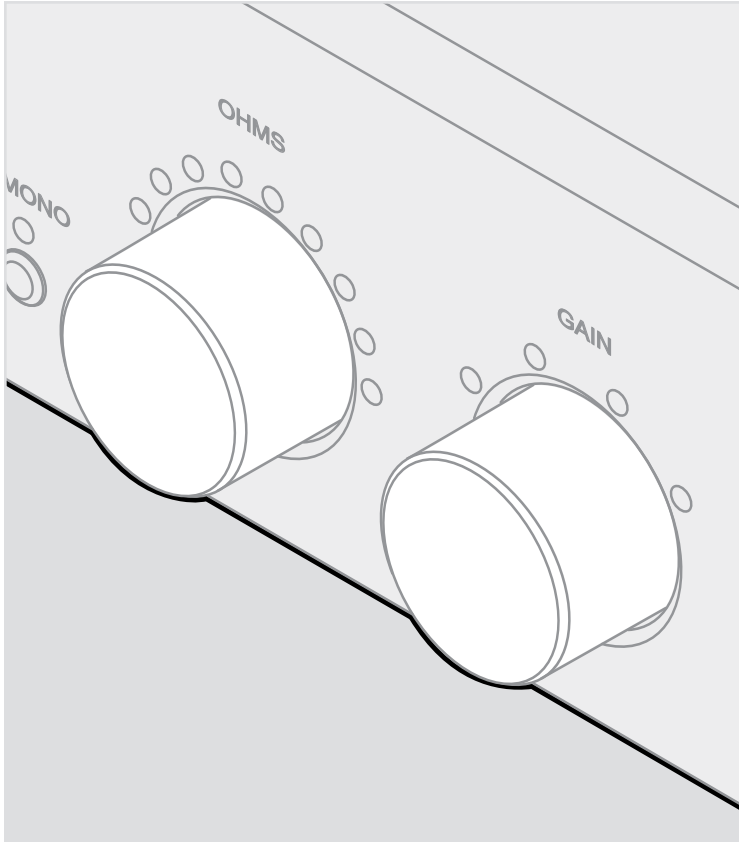

Setting Ohms and Gain

Note: The Ohms selector is disabled on Input 1.

Note: The mono, filter, ohms, and gains settings are stored for each input. When switching inputs, the previous settings are restored when the input is selected.

Ohms Selection: For most MM cartridges, 47k is the recommended loading setting. For MC cartridges, refer to the cartridge manufacturer's recommended load.

If none of the available ohms settings match your preference you can plug a load resistor value of your choice into the RCA jacks labeled "Load" and select it via "OPT" (option) on the Ohms knob.

Gain Selection: You can choose 40db (most MM), 50db (MM, high), 60db (most MC), and 70db (MC, high). Use the minimum gain setting possible to achieve sufficient volume for your listening preferences.

Basic Operation

MasterPhono's main power switch is located on the rear panel, just above the power cord. "O" is off; "I" is on. MasterPhono will remain in standby mode until switched on by activating the Power button on the front panel.

Select the input with the Input knob.

Toggle the LED and meter backlight on and off by briefly pressing the METER button. For other uses of the METER button please go to: www.mofielectronics.com

Adjust the brightness of the LED and meter backlight by pressing and turning the Input knob simultaneously, or pressing the Ohms knob while simultaneously turning the Input knob.

The Subsonic button filters the acoustic feedback (a.k.a., howling) that occurs when the system's bass response shakes your turntable. If the filter is constantly needed, you should relocate your turntable.

The Mono button is for mono cartridges or for listening in mono mode.

Muting is performed by pressing the Gain knob. Mute disengages when you again press the Gain knob. The LED will stay on when MasterPhono is muted.

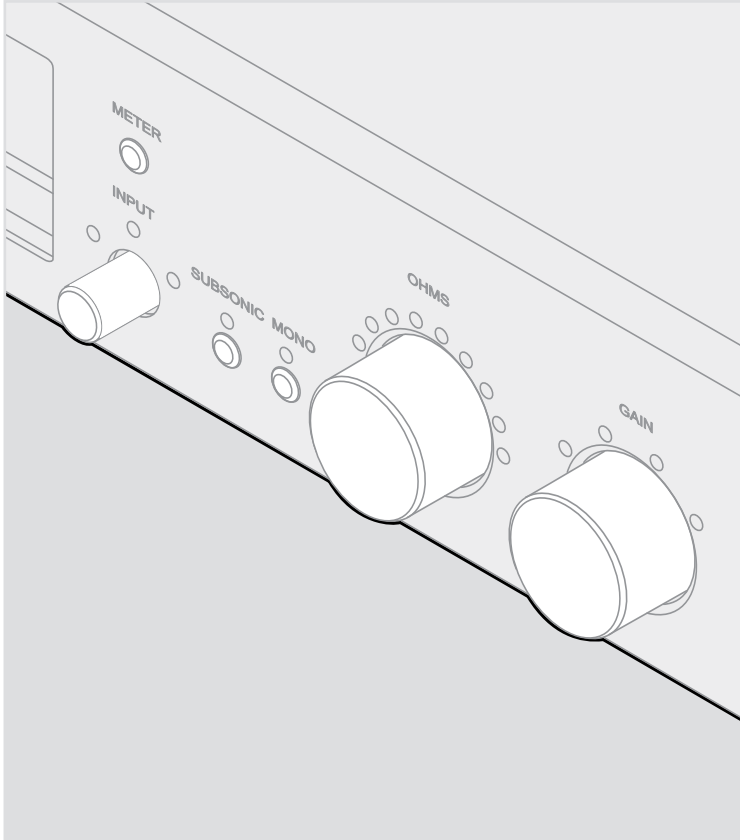

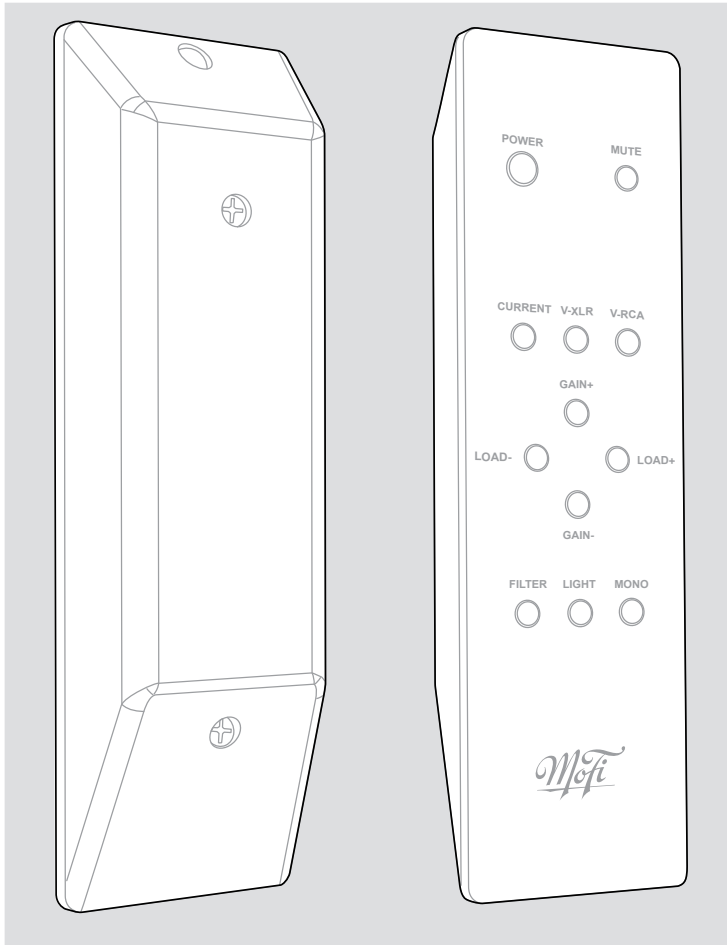

Remote Operation

Battery Installation: With a Phillips screwdriver, remove the two screws to unlock the battery compartment on the remote. Install the battery by matching it to the positive and negative contacts. Close the battery door and replace the screws.

Remote Functions:

POWER: Switches MasterPhono on or puts it in standby mode.

MUTE: Toggles the mute function.

CURRENT, V-XLR, and V-RCA: Selects the corresponding input.

LOAD -/+: Raises and lowers the load or ohm setting.

GAIN -/+: Raises or lowers the gain setting.

FILTER: Toggles the Subsonic filter on and off.

LIGHT: Toggles the LED and meter backlight on and off

MONO: Toggles the mono function on and off.

Troubleshooting

Issue: MasterPhono does not power on.

Possible Solutions:

The rear main power switch or front standby is off.
The power cord is loose.
Try a different outlet.

Check the fuses. There are two fuses in the drawer above the power-cord receptacle. First, remove the power cord. Then, check the active fuse first then replace it with the included spare fuse if needed.

Issue: No sound.

Possible Solutions:

Check your cables, connections, and turntable.
Make sure Mute is off.
If everything seems in order, contact your dealer.

Issue: The lights are too bright or too dim.

Possible Solutions:

Adjust the brightness of the LED and Meter Backlight by pressing and turning the input selector knob simultaneously or pressing the Ohms knob while simultaneously turning the Input knob.

Issue: Hum, buzz, or hiss.

Possible Solutions:

Grounding; the recommended setup is usually the most quiet. Sometimes, the other setups may perform better with your system.

Location; Try moving the MasterPhono to a higher or lower shelf, or sideways to minimize any noise induced by other components

Cable Route; make sure the MasterPhono's RCA or XLR cables are routed away from the power transformers in your other products.

Cables; ensure the RCA and XLR cables are not near or running parallel to power cords.

MasterPhono Feature List

- Standard signal input via RCA and XLR (the “voltage input”)
- 10-position loading adjustment, including “Custom” via RCA plug
- “Current input” used for low source-impedance phono cartridges via RCA or XLR, with transimpedance dynamic loading
- Fully discrete from input to output
- Fully balanced, DC coupled, and servo-controlled from the high-pass filter to the output jacks
- Critical components housed inside a shielded, thermally stable enclosure
- Single-ended RCA and balanced XLR output
- Switchable gain (40db/50db/60db/70db)
- Passive RIAA exclusively using NOS polystyrene and polypropylene film/foil capacitors for better than 1% precision
- All critical resistor 0.1% or 0.5% tolerance for precise filtering and voltages
- Stereo/mono switch
- High-pass filter switch
- Left and right meters for output monitoring and cartridge calibration
- Ultra-low-hum field power supply
- Isolated chassis and signal grounding post for lowest-overall system noise
- Cascaded voltage-regulation stages for lowest noise
- Dual-chassis construction isolates power supply and audio circuits
- Upgradeable software via USB for new updates and features as they become available

MasterPhono™ - Specifications

Inputs:	Current mode & Voltage mode, balanced and unbalanced
Voltage input Loading Options:	15 Ohms, 30 Ohms, 50 Ohms, 75 Ohms, 100 Ohms, 500 Ohms, 1K Ohms, 10K Ohms, 47K Ohms+150pF, & Option
Gain Overall:	(MM) 40db, (MM) 50db, (MC) 60db, (MC) 70db
Output Impedance Balanced:	230 Ohm, Unbalanced: 115 Ohms
Maximum Output	Maximum Output @1% THD, 10 Volts RMS
THD	5mV@1KHZ MM low: < 0.01% A-Weighted 5mV@1KHZ MM high: < 0.01% A-Weighted 0.5mV@1KHZ MC low: < 0.005% A-Weighted 0.5mV@1KHZ MC high: < 0.005% A-Weighted
RIAA Accuracy	20Hz - 20KHz +/- 0.1db using passive R-C technology
Frequency Response	10Hz - 50KHz +/- 0.20db no filter -3.5db @ 10Hz filter ON
Chassis size:	17"W x 3 1/2"H x 15 1/2"D (chassis only) 17 1/2" (including knob and jacks)
Weight:	15lbs
AC Mains:	100VAC - 260VAC, auto switching

FCC Warnings:

Caution: Any changes or modifications to this device not explicitly approved by manufacturer could void your authority to operate this equipment.

Note: This equipment has been tested and found to comply with the limits for a Class B digital device, pursuant to part 15 of the FCC Rules. These limits are designed to provide reasonable protection against harmful interference in a residential installation. This equipment generates, uses and can radiate radio frequency energy and, if not installed and used in accordance with the instructions, may cause harmful interference to radio communications. However, there is no guarantee that interference will not occur in a particular installation. If this equipment does cause harmful interference to radio or television reception, which can be determined by turning the equipment off and on, the user is encouraged to try to correct the interference by one or more of the following measures:

- Reorient or relocate the receiving antenna.
- Increase the separation between the equipment and receiver.
- Connect the equipment into an outlet on a circuit different from that to which the receiver is connected.
- Consult the dealer or an experienced radio/TV technician for help

MoFi ELECTRONICS

www.mofielectronics.com

MoFi Electronics - 1811 W Bryn Mawr Ave Chicago IL