



USA

PRESSURE INDUCTION HEATING RICE COOKER & WARMER OPERATING INSTRUCTIONS

NW-JEC10 / NW-JEC18

● Please read and follow these operating instructions carefully. Misuse of this Rice Cooker may be dangerous because of the high pressure. Please keep these operating instructions at hand for easy reference.

INDEX

IMPORTANT SAFEGUARDS.....	2
IMPORTANT.....	5
ABOUT THE INNER COOKING PAN.....	6
PART NAMES AND FUNCTIONS.....	7
TIPS FOR DELICIOUS RICE.....	9
HOW TO SET THE CLOCK.....	10
HOW TO CHANGE THE NOTIFICATION SOUND.....	10
COOKING RICE	
BASIC COOKING STEPS.....	11
ESTIMATED COOKING TIME.....	14
TIPS FOR COOKING VARIOUS RICE MENUS.....	15
ACTIVATED BROWN RICE (GABA BROWN).....	16
ABOUT "MY RICE".....	17
KEEPING RICE WARM	
REGULAR KEEP WARM AND EXTENDED KEEP WARM....	19
REHEATING RICE.....	21
USING THE TIMER TO COOK RICE	
USING THE TIMER.....	22
RECIPES	
HAND-ROLLED SUSHI.....	24
PAELLA.....	24
CONGEE.....	25
CARROT CAKE STEEL CUT OATMEAL.....	25
CLEANING AND MAINTENANCE.....	26
SELF-CLEANING.....	30
TROUBLESHOOTING GUIDE.....	31
REPLACEMENT PARTS.....	34
IF THE FOLLOWING OCCURS.....	35
ERROR DISPLAYS AND THEIR MEANINGS.....	36
SPECIFICATIONS.....	37

ZOJIRUSHI CORPORATION

IMPORTANT SAFEGUARDS

BASIC SAFETY PRECAUTIONS SHOULD ALWAYS BE FOLLOWED WHEN USING ELECTRICAL APPLIANCES, INCLUDING THE FOLLOWING.

- 1** Read all instructions thoroughly.
- 2** Avoid touching hot surfaces and do not close or clog the steam vent opening under any circumstances. The handles and knobs are provided for your safety and protection.
- 3** To prevent hazardous operation or electric shock, do not immerse power cord, power plug, or rice cooker (except inner cooking pan) in water or other liquids.
- 4** Close supervision is necessary when the appliance is used by or near children.
- 5** Unplug from outlet when not in use and before cleaning. Allow the appliance to cool before adding or removing parts, and before cleaning the appliance. Make sure appliance is OFF when not in use, before putting on or taking off parts, and before cleaning.
- 6** Do not use or operate the appliance with a damaged cord or plug. If the appliance malfunctions or has been damaged in any manner, unplug the appliance and return it to the nearest authorized service facility or dealer for examination, repair or adjustment.
- 7** The use of accessories or attachments not recommended by the appliance manufacturer may be hazardous or may cause malfunction.
- 8** Do not use outdoors.
- 9** Keep the power cord away from hot surfaces and do not let the cord hang over the edge of tables or counters.
- 10** Do not place the appliance on or near a heated surface such as a gas or electric stove, or in a heated oven.
- 11** Always use extreme caution when moving appliances containing hot contents or liquids.
- 12** Plug the cord into a household electrical outlet. To disconnect, turn the power control to OFF, then remove plug from wall outlet.
- 13** Do not use the appliance for other than intended or specified purposes.
- 14** To reduce the risk of electric shock, use only the supplied inner cooking pan.
- 15** This appliance cooks under pressure. Improper use may result in scalds and injuries. Make sure the unit is properly closed before operating.
- 16** Do not cook foods such as applesauce, cranberries, pearl barley or other cereals, split peas, rhubarb, noodles, macaroni or other pasta. These foods tend to foam, froth or splatter and may block the pressure release device.
- 17** Always check the pressure release devices for clogging before use.
- 18** Do not open the pressure rice cooker until the unit has cooled and the internal pressure has been reduced.
- 19** Do not use this pressure rice cooker for pressure frying with oil.

SAVE THESE INSTRUCTIONS

THIS APPLIANCE IS FOR HOUSEHOLD USE ONLY.

This appliance is supplied with a short power cord to reduce the risk of becoming entangled in or tripping over. Extension cords may be used if care is exercised in their use. If an extension cord is used, the marked electrical rating of the cord should be at least as great as the electrical rating of the appliance, and a longer cord should be arranged so that it will not drape over the countertop or tabletop where it can be pulled on by children or tripped over unintentionally.

This appliance has a polarized plug (one blade is wider than the other). To reduce the risk of electric shock, this plug was designed to fit into a polarized outlet in only one direction. If the plug does not fit fully into the outlet, do not attempt to force it or modify it in any way. Simply reverse the plug and insert. If it still does not fit, contact a qualified electrician.

IMPORTANT SAFEGUARDS

Be sure to follow these instructions.

These WARNINGS and CAUTIONS are intended to prevent property damage or personal injury to you and others.

■ The degree of danger or damage by the misuse of this product is indicated as follows

 **WARNINGS** Indicates risk of serious injury or death.

 **CAUTIONS** Indicates risk of injury, household or property damage if mishandled.

■ Prohibited or required actions are indicated as follows

 Indicates a prohibited operation.

 Indicates a requirement or instruction that must be followed.

WARNINGS

To Cook Rice Safely in This Rice Cooker

Because pressure is applied during cooking and Self-Cleaning, incorrect handling of the product is dangerous. There is the risk that rice or other ingredients may boil over, resulting in burns or injury.

 **This Rice Cooker is designed for cooking rice and keeping rice warm as indicated in the Operating Instructions and recipes. Do not use it for anything other than its intended purposes.**

There is the risk of the steam exhaust route becoming clogged, which can cause steam to come out from the gap between the Outer Lid and the Main Body, or cause the Outer Lid to open suddenly, during cooking or Self-Cleaning.

<Examples of foods that must not be used>

- Foods using ingredients that increase in size while cooking (pastes, beans, noodles, etc.).
Boil beans in a separate pot before using them.
- Foods that may bubble over such as those using baking soda.
- Thick foods such as curry and stews.
- Foods with large amounts of oil.
- Foods that bubble up such as jams.
- Foods packaged in plastic bags.
- Foods wrapped in parchment paper, aluminum foil, plastic wrap, etc. or steaming dishes.
- Foods with green leafy vegetables (such as rice porridge with seven herbs); the green vegetables should be cooked separately and added after the rice completes cooking.
- Foods with unpeeled tomatoes.

Never open the Outer Lid or move the Rice Cooker when pressure is applied during cooking or Self-Cleaning.

Do not fill water above the "MAX" Line indicated on the Inner Cooking Pan and cook.

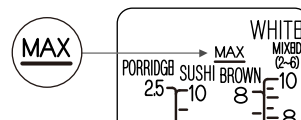

 **Always check that rice or other matter is not stuck around the Lid Hooks, the Hook Holes of the Main Body, the gap between the Main Body and the Outer Lid, the Inner Lid Gasket, the Pressure Control Valve, the Safety Valve, the Inner Lid Filter, or around the Steam Vent before cooking or Self-Cleaning.**

- Rice or other matter stuck on these areas may prevent the Outer Lid from closing completely. During cooking or Self-Cleaning, this may cause steam to come out from the gap between the Outer Lid and the Main Body, or cause the Outer Lid to open suddenly, and rice or other ingredients may boil over. Additionally, for safety purposes, it may prevent the Rice Cooker from activating cooking or Self-Cleaning.
- The Outer Lid may not open if rice or other matter is stuck.

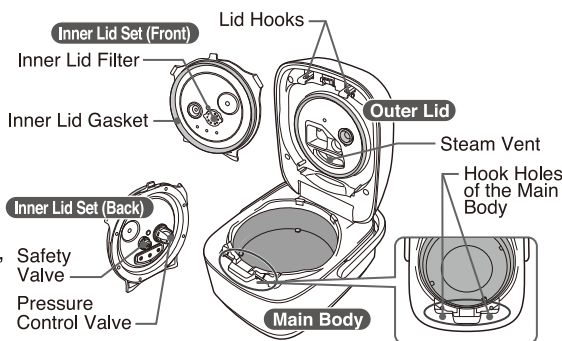

Push down on the Outer Lid until you hear it click shut.

If the Outer Lid is not closed securely, it may open during cooking. Keep Warm or Self-Cleaning.

Press down on the center front edge of the Outer Lid.



When opening the Outer Lid during cooking or Self-Cleaning, be sure that the **PRESSURE indicator on the Display has turned off before opening the Outer Lid.**

Be sure this has turned off.

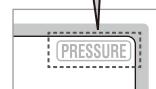

● The illustrations used in this Operating Instructions may vary from the actual product you have purchased.

Continued on the next page

IMPORTANT SAFEGUARDS (cont.)

⚠ WARNINGS



Do not modify the Rice Cooker. Only a repair technician may disassemble or repair this unit.
Attempting to do so may cause fire, electric shock or injury. Make any repair inquiries to Zojirushi Customer Service.



Keep your hands and face away from the Steam Vent.
Doing so may cause burns or scalding. Take special precautions with children and infants.



Do not plug or unplug the Power Cord with wet hands.
Doing so may cause electric shock or injury.



Do not immerse the Rice Cooker in water or splash it with water. Do not pour water directly into the Rice Cooker.
Doing so may cause short circuit or electric shock.

Do not allow liquid to come in contact with the Power Plug or Power Cord.
Doing so may cause short circuit or electric shock.



Do not use the Rice Cooker if the Power Plug or Power Cord is damaged or if the Power Plug is loosely inserted into the electrical outlet.
Doing so may cause electric shock, short circuit or fire.

Do not damage the Power Cord. Do not bend, pull, twist, bundle or attempt to modify the Power Cord. Do not place it on or near high temperature surfaces or appliances, under heavy items or between objects.

A damaged Power Cord can cause fire or electric shock.

Do not use a power source other than 120V AC.

Use of any other power supply voltage may cause fire or electric shock.

Do not allow the Power Plug to come into contact with steam.

Allowing the Power Plug to come into contact with steam after inserting it into the electrical outlet may cause short circuit or fire. When using on a slide-out table or shelf, place the Rice Cooker in a position where the Power Plug does not come into contact with steam.

Do not allow children to use the Rice Cooker unsupervised. Keep it out of the reach of infants.

Children are at risk of burns, electric shock or injury.

Do not drop metal objects such as pins or wires into the Air Intake Duct or Exhaust Duct.

Doing so may cause electric shock or malfunction, resulting in injury.

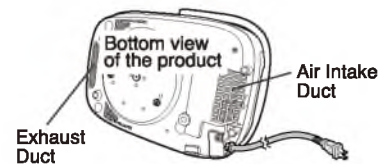
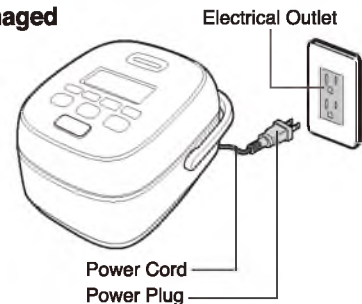

Insert the Power Plug completely and securely into the electrical outlet.

A loosely inserted Power Plug may cause electric shock, short circuit, smoke or fire.

Use only an electrical outlet rated at 15 amperes minimum, and do not plug other devices into the same outlet.

Plugging other devices into the same outlet may cause the electrical outlet to overheat, resulting in fire.

If the blades or surface of the Power Plug become soiled, wipe them clean.

A dirty Power Plug may cause fire.

This appliance is not intended for use by persons (including children) with reduced physical, sensory or mental capabilities, or lack of experience and knowledge, unless they have been given supervision or instruction concerning use of the appliance by a person responsible for their safety. Children should be supervised to ensure that they do not play with the appliance.

Stop using immediately if you notice any of the following symptoms indicating a malfunction or breakdown.

Continued use of the Rice Cooker may cause smoke, fire, electric shock or injury.

- The Power Plug or Power Cord has become very hot.
- The Power Cord is damaged or the electricity turns on and off when touched.
- The body of the Rice Cooker is deformed or unusually hot.
- Smoke is produced from the Rice Cooker or there is a burning smell.
- Some part of the Rice Cooker is cracked, loose or unstable.
- The fan at the bottom does not work during cooking or Self-Cleaning. etc.

If any of the above occurs, unplug the Rice Cooker immediately and contact the store where you purchased it or Zojirushi Customer Service for inspection and/or repair.

IMPORTANT SAFEGUARDS (cont.)

⚠ CAUTIONS



Do not touch hot surfaces during or immediately after use. Be careful of steam when opening the Outer Lid. Be careful not to touch the Inner Cooking Pan when loosening rice.
Touching hot surfaces may cause burns.



Be especially careful with metal parts such as the Inner Lid Set and Inner Cooking Pan.



Do not use the Rice Cooker where it may come into contact with water or near heat sources.

Doing so may cause electric shock, short circuit, or can damage the Rice Cooker.

Do not use cookware other than the provided Inner Cooking Pan.

Doing so may cause the cookware to overheat or the Rice Cooker to malfunction.

Do not use the Rice Cooker on an aluminum sheet or an electric carpet.

The aluminum material may be heated and may cause smoke or fire.

Do not use the Rice Cooker on a surface where the Air Intake Duct or Exhaust Duct can become blocked or covered (such as on paper, cloth, carpet, plastic bag or aluminum sheet).

Doing so may cause breakdown of the Rice Cooker.

Do not place or use the Rice Cooker on unstable surfaces or on surfaces that are vulnerable to heat.

Doing so may cause fire.

Do not use the Rice Cooker on a slide-out table or shelf with insufficient load capacity.

Doing so may damage the slide-out table or shelf, causing the Rice Cooker to fall, resulting in injury or burns. The slide-out table or shelf should have a load capacity of 33 lbs./15 kg or more for the 1.0 L model, and 44 lbs./20 kg or more for the 1.8 L model.

Do not use the Rice Cooker near walls or furniture. Allow enough room for steam to escape if using beneath shelving.

Failing to allow enough room may cause breakdown. Steam or heat may also damage, discolor or deform walls, furniture or shelving.

Do not touch the Open Button when moving the Rice Cooker.

Doing so may cause the Outer Lid to open, resulting in injury or burns.

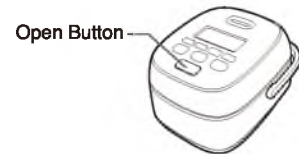

Unplug the Power Plug from the outlet when the Rice Cooker is not in use.

Leaving the Power Plug connected to an outlet may cause the insulation to become damaged, resulting in burns, injury, electric shock, short circuit or fire.



Please allow the Rice Cooker to cool down before cleaning.

Hot parts such as the Inner Lid, Inner Cooking Pan and heating element may cause burns.

Always unplug the Rice Cooker by holding the Power Plug, not by pulling the Power Cord.

Pulling the Power Cord to unplug the Rice Cooker may cause electric shock, short circuit or fire.

If the Power Plug or Power Cord is damaged, it must be replaced by the manufacturer, its service agent or similarly qualified persons to avoid hazards.

Individuals using a medical pacemaker should consult with a physician before using the Rice Cooker.

Using the Rice Cooker may affect a pacemaker.

IMPORTANT

● **Do not cover the Main Body, especially the Steam Vent, with a cloth or other object.**

Doing so may cause breakdown.



● **Do not operate the Rice Cooker if rice or other foreign matter is stuck on the inside of the Main Body, the outside surface of the Inner Cooking Pan or the Side Sensor.**

Doing so may burn the rice or otherwise cause imperfect cooking.



Continued on the next page

IMPORTANT (cont.)

- **Do not raise the Handle during cooking or Self-Cleaning.**

Doing so may cause the Handle to become very hot due to steam.

- **Do not place electronics or objects that are susceptible to magnets in close range of the Rice Cooker.**

Doing so may cause interference with TV, radio, computer, intercom, transceiver, telephone, etc. It may also erase magnetically recorded data (credit card, train pass, audio tape, etc.).

- **Always hold the Rice Cooker by the Handle when carrying it. Do not tilt the Main Body.**

Doing so may cause the contents to spill.

- **Do not damage, drop or deform the Inner Cooking Pan.**

A damaged Inner Cooking Pan may not cook properly.

- **Do not splash the Rice Cooker with water or place it on top of something wet.**

Doing so may cause electric shock or breakdown.

- **Do not cook when the Inner Cooking Pan is empty.**

Doing so may cause breakdown of the Rice Cooker.

- **Do not use the Rice Cooker on top of an induction heating cooker.**

Doing so may cause breakdown.

- **Do not use the Rice Cooker in direct sunlight.**

Doing so may cause discoloration of the Rice Cooker.

- **Do not unplug the Power Plug from the electrical outlet during cooking or Self-Cleaning.**

Steam may billow out, which can be dangerous.

- **Do not use the Rice Cooker where its steam may come into contact with other electrical appliances.**

The steam may cause fire, malfunction, discoloration or deformation of other electrical appliances.

- **Clean the Rice Cooker and the surrounding area before using it.**

This Rice Cooker is equipped with the Air Intake Duct and Exhaust Duct to improve function and performance, but if dust or insects enter the Air Intake Duct or Exhaust Duct, the Rice Cooker may malfunction. If the Rice Cooker malfunctions due to insects, etc. entering the Air Intake Duct or Exhaust Duct, there will be a charge for repairs.

- **This appliance is intended for household use and similar applications listed below.**

- Staff (employee) kitchen area in shops, offices and other working environments.

*This appliance is not intended for use by many unspecified people for a long period of time.

This appliance must not be used in the following areas.

- Farmhouses.
- By clients in hotels, motels and other residential type environments.
- Bed and breakfast type environments.

ABOUT THE INNER COOKING PAN

In order to use the Inner Cooking Pan for many years to come, please observe the following.

Inner Surface (Nonstick Coating)

The Nonstick Coating can peel off if damaged.

Please take special care to prevent damage and follow these precautions.

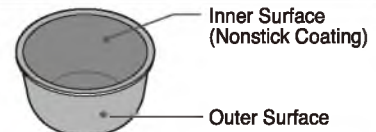

<During Preparation>

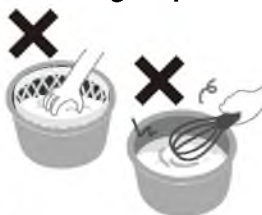

- Remove foreign matter (such as stones) from the rice before cleaning.
- Do not use utensils such as whisks to clean rice.
- Do not place a metal strainer in the Inner Cooking Pan when cleaning rice.
- Use the Inner Cooking Pan only for this Rice Cooker.

<When Cooking Completes>



- Do not pour vinegar into the Inner Cooking Pan (when making sushi rice).
- Do not use a metal ladle (when serving porridge, etc.).
- Do not hit with the Spatula or other utensils (when serving, etc.).

<When Cleaning> → pg. 26

- Do not place utensils or dishes inside the Inner Cooking Pan.
- Do not place in a dishwasher or dish dryer.
- Clean the Inner Cooking Pan immediately after using any seasonings.
- Only use soft cleaning implements such as a sponge when cleaning.



- Do not use such items as thinner, abrasive cleaners, bleach, scrubbing brushes (nylon, metal, etc.), melamine sponges or sponges with a nylon surface.



The Nonstick Coating may wear out with use.

- The Nonstick Coating may eventually discolor or peel off. This will not affect the cooking / Keep Warm performances or its sanitary properties, and is harmless to your health.
- If concerned with the peeling of the Nonstick Coating or if the Inner Cooking Pan deforms, please replace it by purchasing a new one. → pg. 34

Outer Surface

- Heat may cause some discoloration, but this does not affect the cooking results.
- The outer surface touches important sensitive sensors. Be careful not to allow it to get dirty or damaged.
- Note that firmly pushing the bottom surface of the Inner Cooking Pan against a sink, table, or similar items may damage or discolor such items.

PART NAMES AND FUNCTIONS

Steam Vent

- Steam arising from the vent is very hot while rice is cooking. Please exercise care.

Open Button

Press the Open Button to open the Outer Lid.

- The Outer Lid may take a while to open as it is designed to seal tightly to build up pressure inside.
- The Outer Lid will not open while pressure is applied during cooking. This is for safety purposes and does not indicate a malfunction.

About the Lithium Battery

A lithium battery is installed internally so that even if the Power Cord is unplugged, information such as the current time and Menu settings are saved. The lithium battery will wear out with use. → pg. 36

Exhaust Duct
(bottom front of the Main Body)

Air Intake Duct
(bottom back of the Main Body)

When opening and closing the Outer Lid, keep your fingers away from the gap at the back of the Main Body (shaded area on the right figure).

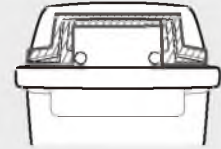

Failure to do so may cause injury.

Handle

Use the Handle for carrying.

- Do not shake the product forcefully while holding it by the Handle. The Main Body may flip, resulting in injury.

Power Cord

Power Plug

Twist Tie

- Please remove the Twist Tie holding the Power Cord before use.
- Do not use the Power Cord bundled up. Doing so may cause the Power Cord to become excessively hot, resulting in malfunction.

CONTROL PANEL

- Press buttons down firmly.
- The raised dot and dash (●, —) in the center of the START/REHEAT and CANCEL buttons and the Notification Sounds are provided for individuals with visual impairment.

Display

Black lines that may appear on the LCD when wiped with a cloth are caused by static electricity and do not indicate a malfunction. Such lines disappear shortly.

This Display is an example only, and will not appear in actual use.

RICE TYPE button

Use this button to select the type of rice. → pg. 12

MY RICE button

Use this button to enter feedback for MY RICE. → pg. 17
(This is not a button to start MY RICE cooking.)

START/REHEAT light

CANCEL button

- Use this button to cancel the selected setting or function in operation.
- Use this button when changing the Notification Sound. → pg. 10

START/REHEAT button

Use this button to initiate cooking or reheating.



PRESSURE indicator

Turns on in the Display when pressure is applied during cooking.

KEEP WARM light

KEEP WARM button

- Use this button to select the Regular Keep Warm or Extended Keep Warm mode.
- Use this button to restart the Keep Warm mode. → pg. 20

TIMER light

TIMER button

Use when cooking rice using the Timer function. → pg. 22

SELF-CLEAN button

Use this button to perform Self-Cleaning. (Press and hold for 1.5 seconds or longer.) → pg. 30

MENU SELECT button

Use this button for setting the menu you will be using. → pg. 12

TIME SETTING button



- Use this button when adjusting the current time. (Press and hold for 1.5 seconds or longer.) → pg. 10
- Use this button when setting the scheduled time for TIMER cooking. → pg. 22

Continued on the next page

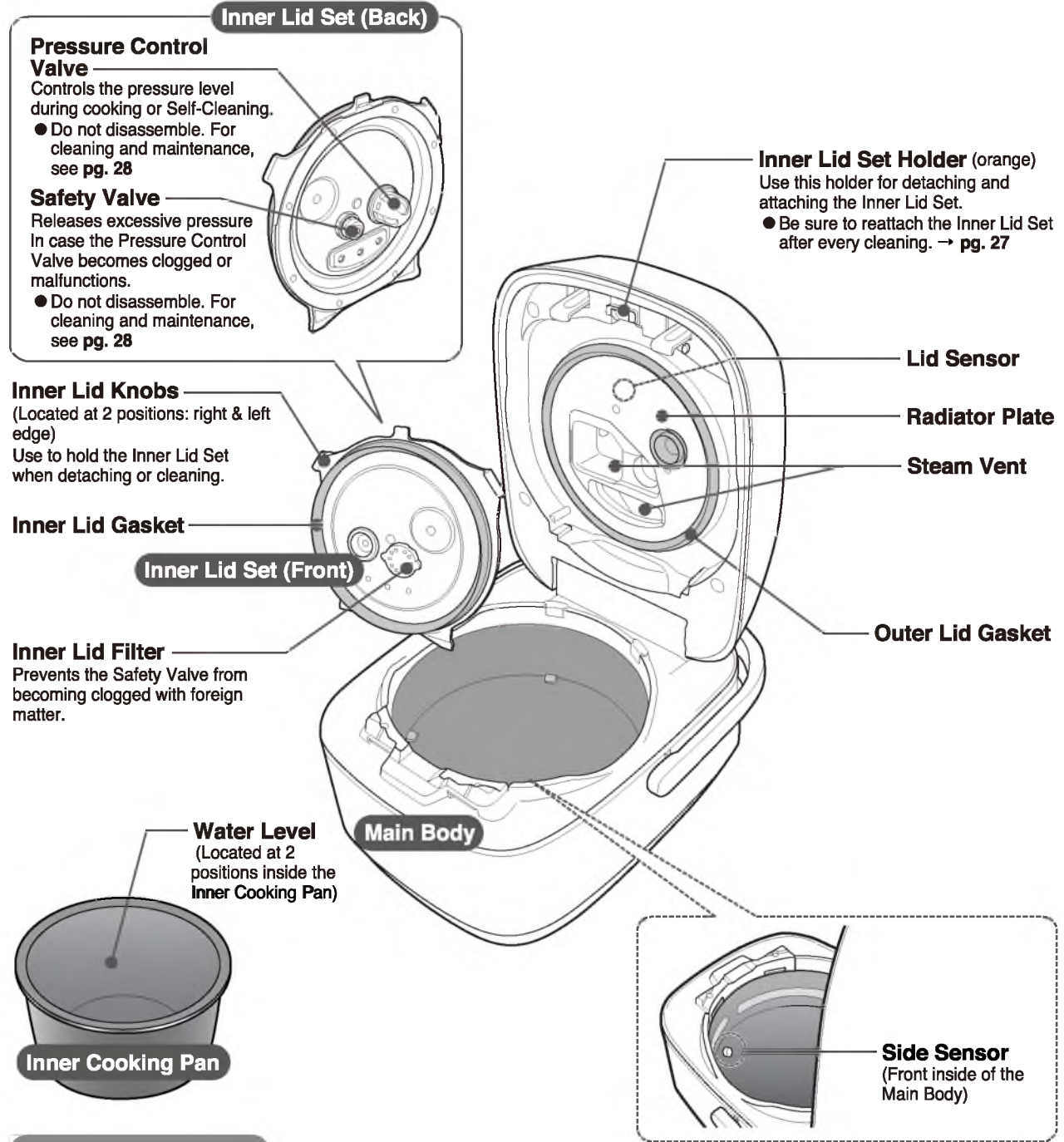
PART NAMES AND FUNCTIONS (cont.)



ACCESSORIES

<p>Spatula</p>  <p>Can be placed standing upright.</p>	<p>Measuring Cup</p>  <p>(1 Cup = approx. 6.1 oz./approx. 180 mL)</p>
--	---

TIPS FOR DELICIOUS RICE

TIPS FOR COOKING DELICIOUS RICE

● Measure rice accurately

Be sure to use the Measuring Cup provided, as other measuring cups may differ. Level the rice off at the top of the cup to maintain accuracy.

● Clean rice quickly Prepare a bowl to pool water

- ① **Rinse rice** First, pour plenty of water into the Inner Cooking Pan from the bowl and stir the rice loosely by hand 2 or 3 times (for 10 seconds or less). Drain the water immediately afterwards. Repeat twice.
- ② **Wash rice** Wash by stirring the rice by hand 30 times, pour plenty of water from the bowl and stir the rice loosely again. Drain the water immediately afterwards. Repeat this washing process 2-4 times.
- ③ **Rinse rice** Lastly, pour plenty of water from the bowl and rinse the rice. Repeat twice.



(Complete steps ①-③ within 10 minutes.)

- Use a different method to wash jasmine white rice and steel cut oatmeal if such a method is written on the bag containing the rice or oatmeal. If no washing method is written on the bag, follow the instructions given above.

Warning!

Do not clean the rice or adjust the amount of water using hot water (95°F/35°C or above). Doing so will cause the rice to be cooked improperly.

● Adjust the amount of water accordingly

Be sure to adjust the amount of water on a flat surface. The Water Level Line is a guideline. Adjust the amount of water according to preference, rice type, and crop age.

Type of Rice	New crop	Old crop
Water Adjustment	Reduce water slightly from the normal level	Add a little water to the normal level

- If you add too much water, it may boil over through the Steam Vent.

● Do not use strongly alkalinized ionic water

Do not use alkalinized ionic water that is over pH 9. Rice cooked with strongly alkalinized ionic water may appear yellow or become too glutinous.

● Stir and loosen rice immediately after cooking has completed

Doing so releases excess moisture, resulting in rice that is perfectly cooked with a fluffy texture. Loosen the rice within 10 minutes after cooking completes. Not loosening the rice may cause it to clump, become too glutinous or burn.

When Cooking 6 Cups of White Rice

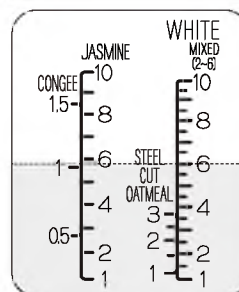

Add water to Water Level Line 6 for WHITE.

This illustration shows the Inner Cooking Pan of the 1.8 L model.

TIPS FOR USING THE KEEP WARM MODE

● When keeping rice in the Inner Cooking Pan for later consumption, use the Keep Warm mode.

- If rice is left in the Inner Cooking Pan with the Power Plug unplugged or with the Keep Warm mode canceled, the rice may develop a foul odor or condensed moisture may fall on the rice, making it soggy.

● To prevent the rice from becoming dry, wet, developing an odor or turning yellow, do not use the Keep Warm mode for the following.

- Keeping a small amount of rice warm for a long period.
- Keeping rice warm for 12 hours or more in the Regular Keep Warm mode or 24 hours or more in the Extended Keep Warm mode. (This may differ depending on the menu setting.)
- Adding additional rice while keeping rice warm.
- Reheating cold rice.
- Keeping porridge, congee, or steel cut oatmeal warm.
- Keeping rice warm when it contains additional ingredients and seasonings (mixed rice).
- Keeping foods other than rice warm.
- Keeping rice warm with the Spatula left inside the Rice Cooker.

● When keeping a small amount of rice warm, gather the rice toward the center of the Inner Cooking Pan.

- As the amount of rice kept warm decreases, the rice may dry or become wet. To minimize this, gather the rice toward the center of the Inner Cooking Pan while keeping warm.

Gather rice in center



HOW TO SET THE CLOCK

if the clock is inaccurate, set the correct time as shown below.

- The clock is displayed in 24-hour (military) time.

e.g. If the current time is 15:01 but displays 14:56.

1 Set the Inner Cooking Pan and insert the Power Plug into an electrical outlet.

2 Press and hold the ◀ or ▶ button for 1.5 seconds or longer.

- Pressing the ◀ or ▶ button displays the menu selection screen. Continue holding it. When the button is held for 1.5 seconds or longer, the time display starts blinking.
- If the time display does not start blinking, press the CANCEL button and start the process again.

3 Once the time display starts blinking, immediately adjust the clock to the current time.

- ▶ : Each press advances the time in 1-minute increments.
- ◀ : Each press reverses the time in 1-minute increments.
- Press and hold either button to quickly adjust in 10-minute increments.

4 The time display will stop blinking after 3 seconds, indicating the Time Setting is completed.

If the time display still does not show the current time, repeat Step 2 to readjust the time.

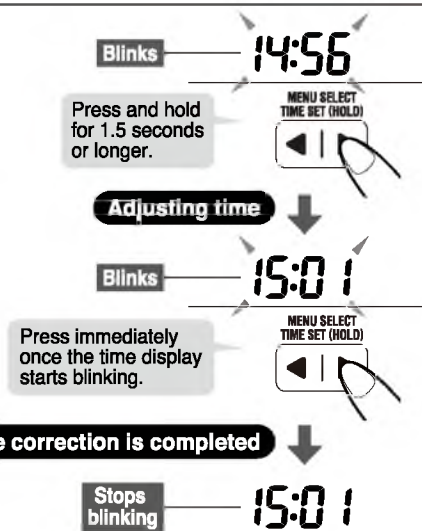

- Although the clock display turns off when the Power Plug is disconnected, the current time will reappear when the Power Plug is connected again.
- Although the clock is set before shipment from the factory, certain conditions such as room temperature may cause it to display an inaccurate time.
- If the clock is inaccurate, cooking will not be completed at the time you set for the Timer.
- The clock cannot be changed during cooking, reheating, Regular Keep Warm, Extended Keep Warm, timer cooking, or Self-Cleaning.

HOW TO CHANGE THE NOTIFICATION SOUND

This product is equipped with a Notification Sound function, which will inform you when the Rice Cooker begins cooking, when the Timer is set, or when cooking has completed. You can choose the sound type from Melody, Beep or Mute.

Types of Notification Sounds

You can choose the Notification Sounds from the following

Types of Notification Sounds and their meanings	Melody	Beep	Mute
When	Default setting at the time of shipment from the factory.	Choose this setting to change from a Melody.	Choose this setting to mute the Notification Sound.
Cooking or Self-Cleaning has begun	"Twinkle, Twinkle, Little Star"	a beep	no sound
Timer is set	"Twinkle, Twinkle, Little Star"	a beep	no sound
Cooking, reheating, or Self-Cleaning has completed	"Amaryllis"	beeps 5 times	no sound
The Outer Lid is not closed during Keep Warm		four short beeps	no sound
The rice has not been loosened after cooking completion		four short beeps	no sound

How to Change the Notification Sound

1 Set the Inner Cooking Pan and insert the Power Plug into an electrical outlet.

2 Hold the CANCEL button for more than 3 seconds.

Each time the CANCEL button is held for more than 3 seconds, the Notification Sound will change.

① **Melody**

It will play "Amaryllis" when the sound setting is completed.

② **Beep**

It will beep 3 times when the sound setting is completed.

③ **Mute**

It will beep 1 time when the sound setting is completed.

3 The setting is completed when the desired Notification Sound is heard.

- The selected Notification Sound is stored even if the Power Plug is disconnected from the electrical outlet.

- You cannot change the Melody Signal for the initiation of Reheating. (When the Sound Signal function is set to Mute, the Melody Signal does not sound upon the initiation of Reheating.)
- You cannot change the Notification Sound during cooking, reheating, Regular Keep Warm, Extended Keep Warm, timer cooking, or Self-Cleaning.
- If you find it difficult to change/select the Notification Sound, please start over from Step 1.
- Regardless of the setting, the buzzer indicating an error will sound.

COOKING RICE

BASIC COOKING STEPS

Wash the Inner Cooking Pan, Inner Lid Set, Spatula, and Measuring Cup before initial use. → pg. 26 - pg. 29

Check all parts before cooking.

Check that all parts are clean and free of foreign matter before cooking. Make sure that rice or other matter is not stuck to the parts illustrated on the right. → pg. 28 - pg. 29

- Rice or other matter stuck on these areas may prevent the Outer Lid from closing completely. It may also cause steam to come out from the gap between the Outer Lid and the Main Body, or the Outer Lid may open suddenly and rice or other ingredients may boil over. Additionally, for safety purposes, it may prevent the Rice Cooker from cooking.

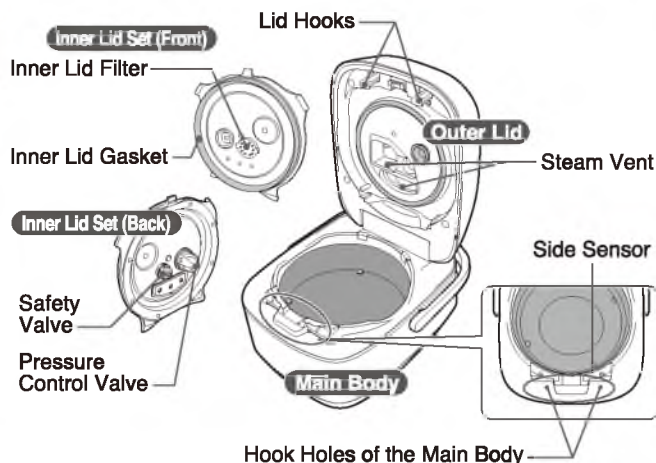

1

Measure the rice with the provided Measuring Cup.

Overfill the Measuring Cup with rice, then level off.



2

Clean the rice and adjust the amount of water.

- ① Clean the rice. → See "TIPS FOR COOKING DELICIOUS RICE" on pg. 9
 - ② On a flat leveled surface, pour water over the rice in the Inner Cooking Pan, filling to the Water Level Line that matches the number of cups of rice you are cooking and the Menu setting. → pg. 15 - pg. 16
 - ③ For an accurate measurement, level the surface of the rice.
- The rice may be cooked immediately after cleaned, as soaking is not required. Soaking the rice will soften the texture of the rice.
 - The Water Level Line serves as a standard guideline and the amount of water should be adjusted according to preference. (Adjust 1-2 mm above or below the indicated Water Level Line.)

3

Place the Inner Cooking Pan into the Main Body, and attach the Inner Lid Set. Close the Outer Lid.

Be sure to wipe moisture and foreign matter off the outer surface of the Inner Cooking Pan, the inside of the Main Body, and the Inner Lid Set.

- The Outer Lid may not close smoothly as it is designed to lock during pressure cooking for safety purposes. Push down on the Outer Lid until you hear it click shut.

4

Insert the Power Plug into an electrical outlet.

- The clock will appear when you connect the Plug.

Continued on the next page

COOKING RICE (cont.)

5

Press the **RICE TYPE** button and select the type of rice.

- The setting at the time of shipment from the factory is **WHITE**.

Each press of the button changes the selected setting that is blinking on the Display in the following order: WHITE → JASMINE → BROWN → STEEL CUT OATMEAL.



Rice Type For explanation purposes, the figure shows all rice types displayed at once.



- The menu items which are displayed vary depending on the selected rice type. → pg. 15 - pg. 16

6

Press the **◀** or **▶** button and select the menu setting.

- The Menu setting at the time of shipment from the factory is **WHITE** (REGULAR).

Each press of the button changes the blinking menu setting on the Display in the following order: FIRMER → FIRM → REGULAR → SOFT → SOFTER → UMAMI → QUICK → MIXED → SUSHI → PORRIDGE → CONGEE → GABA.

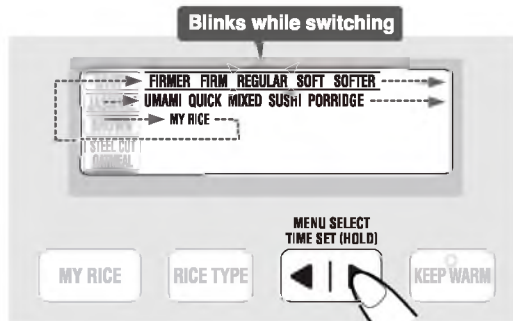

For details on the selectable menu settings and the characteristics of each, see pg. 15 - pg. 16.

Menu For explanation purposes, the figure shows all menu settings displayed at once.

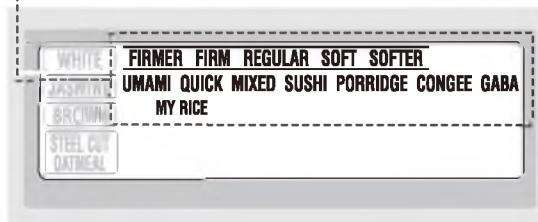

- The menu items which are displayed vary depending on the selected rice type. → pg. 15 - pg. 16
- When STEEL CUT OATMEAL is selected, the REGULAR menu setting turns on.
- When the rice type is not STEEL CUT OATMEAL, press and hold a button to quickly cycle through the selections. Cycling stops when the menu setting returns to REGULAR.
- Some menu settings will remain stored in memory until you change the setting, while others are not stored.
→ See "ESTIMATED COOKING TIME /MENU SETTINGS THAT APPLY PRESSURE" on pg. 14

Press the **▶** button to change in the → direction.

Press the **◀** button to change in the ← direction.

Selecting the rice texture

- The texture for white rice (degree of stickiness and firmness after cooking) can be selected from the following 5 stages.

FIRMER FIRM REGULAR SOFT SOFTER

Less sticky ← → More sticky

COOKING RICE (cont.)

7

Press the **START/REHEAT** button.



The melody (beep) sounds, and cooking begins. The START/REHEAT light turns on, and the Display shows the estimated time (in minutes) until cooking completes.

- When the Outer Lid is not securely closed, the buzzer will sound (four short beeps) to notify you. Push down on the Outer Lid slowly and securely until you hear it click shut.
- Make sure the Rice Cooker is not in the Keep Warm mode, then press the START/REHEAT button. If the Keep Warm light is on, the reheating process will start. → pg. 21
- If you want to know the current time during the cooking process, press the ◀ or ▶ button and the Display will switch.
- With menu settings that involve pressurization, the **(PRESSURE)** indicator on the Display turns on when pressure is being applied.



Ex. Display when rice type WHITE and menu setting SOFTER are selected

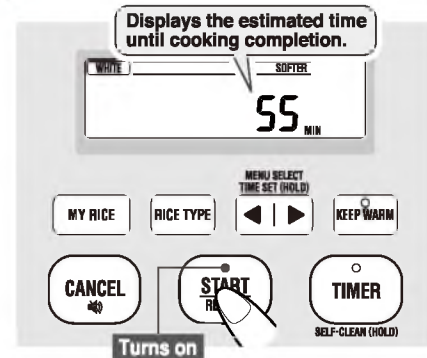

- The estimated time until cooking completion may differ from the actual time required. The actual time of cooking completion may vary depending on factors such as the room or water temperature, the voltage, or the water measurement.
- The Rice Cooker will make adjustments to the estimated time until cooking completion when it reaches the steaming process. The estimated time until cooking completion may increase or decrease suddenly during this process.

8

When the melody (beep) to indicate cooking completion sounds, stir and loosen the rice immediately.

When cooking completes, it will automatically switch to the Keep Warm mode. → See “KEEPING RICE WARM” on pg. 19
The KEEP WARM light turns on or blinks and the START/REHEAT light turns off. The length of time that the rice has been kept warm by Regular Keep Warm or Extended Keep Warm is displayed in hours (h).

Before opening the Outer Lid, make sure that steam is not coming out from the Steam Vent and that the **(PRESSURE)** indicator has disappeared from the Display.

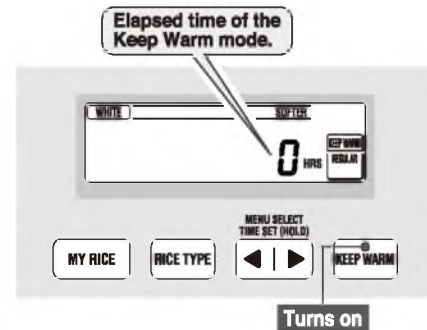

When it switches to the Keep Warm mode, immediately stir and loosen the rice. By stirring and loosening the rice and removing excess moisture, you prevent the rice from hardening, becoming soggy, or becoming burnt.

- Be careful not to burn yourself when stirring and loosening rice.
- It is recommended that you divide the rice into 4 equal parts and loosen each 1/4 part separately.
- If you forget to loosen the rice, the buzzer will sound (four short beeps) to remind you. Loosen the rice and close the Outer Lid. → See “Rice Loosening Reminder” on pg. 20



Do not close the Outer Lid with the Spatula inside the Rice Cooker. Doing so may make the Outer Lid difficult to open.

- Depending on cooking conditions, the bottom portion of the rice may become slightly browned.
- Depending on the heat convection while cooking, the surface of the finished rice may look uneven.
- Immediately after cooking is completed, the Outer Lid will be tightly sealed and some time may be required before it opens.

9

After use, remove all the rice from the Inner Cooking Pan, press the **CANCEL** button, unplug the Power Plug from the electrical outlet, and then clean the Rice Cooker.



- Do not begin cleaning the Rice Cooker until the Main Body has cooled. → pg. 26 - pg. 30

NOTE

You can switch the Notification Sounds (melody, beep) that alert you when certain actions occur. You can also switch the Outer Lid Close Reminder and Rice Loosening Reminder so they are Mute.
→ See “HOW TO CHANGE THE NOTIFICATION SOUND” on pg. 10

Continued on the next page

COOKING RICE (cont.)

Be careful that the contents do not boil over.

When adjusting the amount of water to the PORRIDGE, CONGEE, or STEEL CUT OATMEAL Water Level Line, do not cook using Menu settings other than PORRIDGE, CONGEE, or STEEL CUT OATMEAL. → pg. 15 - pg. 16
Using any other Menu setting may cause the contents to boil over.

- The PORRIDGE, CONGEE, and STEEL CUT OATMEAL menu setting selections will not be saved. When cooking porridge, congee, or steel cut oatmeal, select the corresponding menu setting each time.

IMPORTANT

Before opening the Outer Lid, make sure that steam is not coming out from the Steam Vent and that the (PRESSURE) indicator has disappeared from the Display.

- If it becomes necessary to open the Outer Lid during cooking or to cancel cooking, press and hold the CANCEL button for 1 second or longer. Be cautious of the Steam Vent as steam will be forced out.
- Even if the (PRESSURE) indicator has disappeared, if you feel resistance when pressing the Open Button to open the Outer Lid, do not force it open. Allow the Rice Cooker to cool, and then try again. If you force the Outer Lid open, the contents may boil over, which could cause burns.

- When cooking more than one pot of rice consecutively, or cooking right after cancelling the Keep Warm mode, allow the Rice Cooker to cool for 50 minutes or longer. If the Main Body and the Outer Lid are hot, the rice may not cook well.

Cooking rice without first allowing the Rice Cooker to cool may lead to a longer cooking time. (Up to approximately 60 minutes.) Also, the estimated time until cooking completion may not be displayed for some time in this situation.

TIPS

- To cool the Main Body and Outer Lid quickly, please try the following:
- Fill the Inner Cooking Pan with cold water and place it in the Main Body.
 - Open the Outer Lid, remove the Inner Lid Set and allow the Radiator Plate to cool.

ESTIMATED COOKING TIME/MENU SETTINGS THAT APPLY PRESSURE

— indicates a menu setting that will be stored in memory after it is selected once.

		Menu Settings that Apply Pressure	1.0 L model	1.8 L model
FIRMER		●	Approx. 46 minutes – 53 minutes	Approx. 51 minutes – 57 minutes
FIRM		●	Approx. 47 minutes – 54 minutes	Approx. 53 minutes – 59 minutes
REGULAR		●	Approx. 49 minutes – 55 minutes	Approx. 54 minutes – 60 minutes
SOFT		●	Approx. 50 minutes – 57 minutes	Approx. 55 minutes – 61 minutes
SOFTER		●	Approx. 52 minutes – 58 minutes	Approx. 56 minutes – 62 minutes
UMAMI		●	Approx. 70 minutes – 76 minutes	Approx. 73 minutes – 79 minutes
QUICK		●	Approx. 25 minutes – 34 minutes	Approx. 29 minutes – 44 minutes
MIXED		●	Approx. 70 minutes – 79 minutes	Approx. 73 minutes – 79 minutes
SUSHI		—	Approx. 62 minutes – 69 minutes	Approx. 58 minutes – 67 minutes
PORRIDGE		—	Approx. 62 minutes – 68 minutes	Approx. 61 minutes – 76 minutes
MY RICE*		●	Approx. 43 minutes – 75 minutes	Approx. 43 minutes – 79 minutes
JASMINE	REGULAR	●	Approx. 52 minutes – 59 minutes	Approx. 57 minutes – 63 minutes
	QUICK	●	Approx. 28 minutes – 38 minutes	Approx. 32 minutes – 47 minutes
	CONGEE	—	Approx. 83 minutes – 91 minutes	Approx. 82 minutes – 91 minutes
BROWN	REGULAR	●	Approx. 76 minutes – 83 minutes	Approx. 64 minutes – 80 minutes
	GABA	●	Approx. 198 minutes – 205 minutes	Approx. 200 minutes – 214 minutes
STEEL CUT OATMEAL		—	Approx. 59 minutes – 66 minutes	Approx. 60 minutes – 66 minutes

*The MY RICE menu setting adjusts the cooking method according to the texture that is preferred by your family. As a result, the cooking time will vary.

- The above table is based on the testing conditions of 120 volts, a room temperature of 68°F (20°C), and water at a starting temperature of 64.4°F (18°C).
- The above lengths of time are measured from Cooking until the Keep Warm process. Actual times may vary depending on the voltage, room temperature, season, and the amount of water used.
- The MIXED menu setting requires a longer cooking time to allow the rice to absorb seasonings.

TIPS FOR COOKING VARIOUS RICE MENUS

When cooking types of rice with assigned MENU settings:

*Capacity is measured in the supplied rice measuring cup, using uncooked rice.

Rice Selection	Type of rice to use	Menu Setting	Water Level	Cooking Capacity [cups]*	Notes and Advice
WHITE	Short/Medium Grain White Rice	FIRMER	WHITE	1.0 L: 0.5–5.5 1.8 L: 1–10	• Cooks white rice to the least sticky and firmest texture for this product.
	Short/Medium Grain White Rice	FIRM	WHITE	1.0 L: 0.5–5.5 1.8 L: 1–10	• Cooks white rice to a less sticky and firmer texture than REGULAR.
	Short/Medium Grain White Rice	REGULAR	WHITE	1.0 L: 0.5–5.5 1.8 L: 1–10	• Cooks white rice to the standard texture for this product.
	Short/Medium Grain White Rice	SOFT	WHITE	1.0 L: 0.5–5.5 1.8 L: 1–10	• Cooks white rice to a more sticky and softer texture than REGULAR.
	Short/Medium Grain White Rice	SOFTER	WHITE	1.0 L: 0.5–5.5 1.8 L: 1–10	• Cooks white rice to the most sticky and softest texture for this product.
	Short/Medium Grain White Rice	UMAMI	WHITE	1.0 L: 0.5–5.5 1.8 L: 1–10	• Soaks and steams rice longer for a sweeter taste.
	Short/Medium Grain White Rice	QUICK	WHITE	1.0 L: 0.5–5.5 1.8 L: 1–10	• Cooks white rice faster. Please note that the rice texture may be slightly harder.
	Short/Medium Grain White Rice	MIXED	WHITE	1.0 L: 0.5–4 1.8 L: 2–6	<ul style="list-style-type: none"> • Seasonings should be mixed with soup stock or water and then added to the rice. After adjusting the amount of water, stir thoroughly. If the seasonings are added directly to the rice or if not mixed properly, scorching or imperfect cooking may occur. • The recommended amount of ingredients should be 30-50% of the rice weight. • Chop ingredients into small pieces and place on top of rice without mixing them into the rice.
	Short/Medium Grain White Rice	SUSHI	SUSHI	1.0 L: 0.5–5.5 1.8 L: 1–10	• Rice is firmer than rice cooked using the FIRMER setting.
	Short/Medium Grain White Rice	PORRIDGE	PORRIDGE	1.0 L: 0.5–1.5 1.8 L: 0.5–2.5	<ul style="list-style-type: none"> • The recommended amount of ingredients should be 30-50% of the rice weight. • Chop ingredients into small pieces and place on top of rice without mixing them into the rice. • Ingredients that do not cook easily should not be used in large amounts. • Boil green leafy vegetables separately and add them after the rice porridge has finished cooking.
Short/Medium Grain White Rice	MY RICE	WHITE	1.0 L: 0.5–5.5 1.8 L: 1–10	• By entering feedback about rice cooked using MY RICE in the Rice Cooker, changes will be made to the cooking flow to meet the texture you prefer. → See pg. 17.	

Less

 Rice softness
 → pg. 12

More

Continued on the next page

TIPS FOR COOKING VARIOUS RICE MENUS (cont.)

*Capacity is measured in the supplied rice measuring cup, using uncooked rice.

Rice Selection	Type of rice to use	Menu Setting	Water Level	Cooking Capacity [cups]*	Notes and Advice
JASMINE	Jasmine White Rice	REGULAR	JASMINE	1.0 L: 0.5-5.5 1.8 L: 1-10	• Depending on the rice brand, it may be slightly harder than normal.
	Jasmine White Rice	QUICK	JASMINE	1.0 L: 0.5-5.5 1.8 L: 1-10	• Cooks Jasmine white rice faster. Please note that the rice texture may be slightly harder.
	Jasmine White Rice	CONGEE	CONGEE	1.0 L: 0.5-1 1.8 L: 0.5-1.5	<ul style="list-style-type: none"> • The recommended amount of ingredients should be 30-50% of the rice weight. • Chop ingredients into small pieces and place on top of rice without mixing them into the rice. • Ingredients that do not cook easily should not be used in large amounts. • Boil green leafy vegetables separately and add them after the rice congee has finished cooking.
BROWN	Short/Medium Grain Brown Rice	REGULAR	BROWN	1.0 L: 1-4 1.8 L: 2-8	<ul style="list-style-type: none"> • Cooks brown rice. • If white rice or rinse-free rice is mixed with brown rice, it may boil over or imperfect cooking may occur. Therefore, a mixture like this is not recommended.
	Short/Medium Grain Brown Rice	GABA	BROWN	1.0 L: 1-4 1.8 L: 2-8	<ul style="list-style-type: none"> • Activates brown rice for increased nutritional values. • Compared to the normal cooking of brown rice, this option results in brown rice that is softer and easier to chew.
STEEL CUT OATMEAL	Steel Cut Oatmeal	—	STEEL CUT OATMEAL	1.0 L: 0.5-2.5 1.8 L: 1-3	<ul style="list-style-type: none"> • Adjust the amount of water according to your preference. For firmer oats → Use less water. For softer oats → Use more water.

ACTIVATED BROWN RICE (GABA BROWN)

This Rice Cooker has two settings for cooking brown rice. The GABA BROWN setting on the menu activates brown rice for increased nutritional value.

GABA BROWN SETTING:

When GABA BROWN is selected on the menu, the Rice Cooker will begin activating the brown rice, after which it will start cooking automatically. During the brown rice activation process, the temperature in the Inner Cooking Pan is kept at approx. 104°F (approx. 40°C) for approx. 2 hours. Cooking will take longer to complete.

→ See pg. 14 “ESTIMATED COOKING TIME”.

By activating brown rice, GABA (gamma-aminobutyric acid), a naturally occurring nutrient in brown rice, increases to about 150% of the amount contained in non-activated brown rice. This process also makes brown rice softer, thus making it readily edible.

*What is GABA?

GABA (gamma-aminobutyric acid) is a type of amino acid said to lower blood pressure and relieve stress.

ABOUT “MY RICE”

What is MY RICE?

When the user **enters feedback (firmness, Stickiness)** in the Rice Cooker after cooking rice using the MY RICE menu setting, changes will be made to the cooking flow to meet the texture you prefer.

HOW IT WORKS



To adjust the texture so that it is even closer to your preference, repeat Steps ② and ③.

ENTERING FEEDBACK

For both **FIRMNESS** and **STICKINESS**, select “**TOO MUCH**,” “**OK**,” or “**NOT ENOUGH**.”

	FIRMNESS	STICKINESS
TOO MUCH	Rice is firmer than preferred.	Rice is more sticky than preferred.
OK	Firmness is just right.	Stickiness is just right.
NOT ENOUGH	Rice is softer than preferred.	Rice is less sticky than preferred.

Ex. Entering feedback when you felt that the cooked rice was **too firm and not sticky enough** compared to your family’s preferred texture.

1 Press the **MY RICE** button to display the MY RICE selection screen. The **FIRMNESS** indicator turns on.

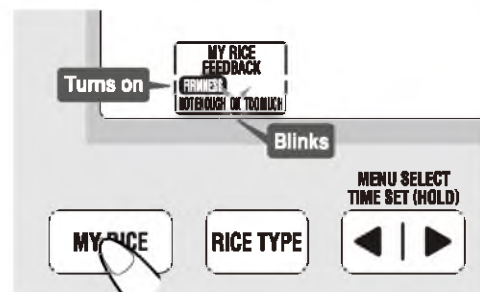

2 Press the **RIGHT** button so that **TOO MUCH** is blinking.

● If you felt that the cooked rice was too soft, press the **LEFT** button so that **NOT ENOUGH** is blinking.

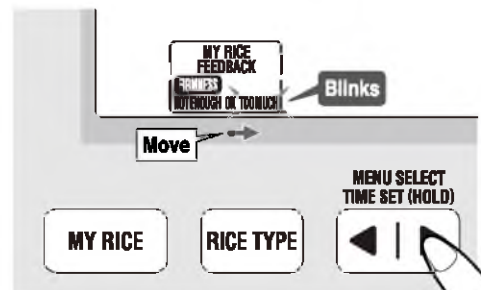

Continued on the next page

ABOUT “MY RICE” (cont.)

3

When the **MY RICE** button is pressed, the Notification Sound beeps (two long beeps) to confirm your feedback for FIRMNESS has been received. Next, the STICKINESS indicator turns on and the OK indicator blinks.

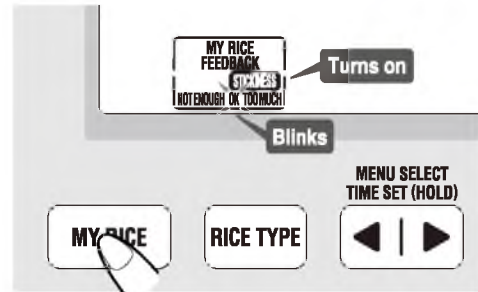

4

Press the **◀** button to select NOT ENOUGH. (The NOT ENOUGH indicator blinks.)

- If you felt that the cooked rice was too glutinous, press the **▶** button so that TOO MUCH is blinking.

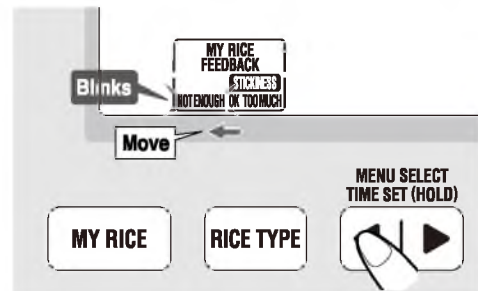

5

Press the **MY RICE** button to confirm the STICKINESS. A melody sounds, and the feedback process is complete.

- A melody sounds, and the MY RICE indicator on the Display turns on. The display returns from the MY RICE selection screen to the original display.

- If the texture adjustment has reached the limit, the Notification Sound will notify you (four short beeps) when you enter your feedback. To adjust the texture further, adjust the amount of water. → **pg. 31**

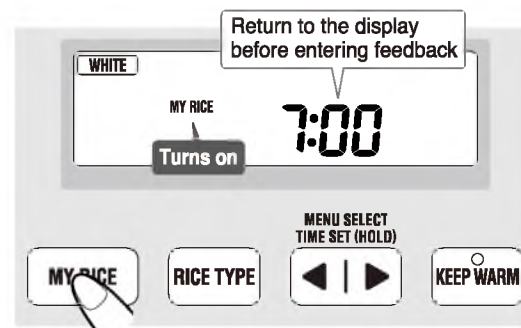

The next time you cook rice with the MY RICE menu setting, the rice will be softer and stickier than it was this time.

NOTE

- The MY RICE menu setting can be selected only when the rice type is WHITE.
- MY RICE feedback can be entered either while the rice is being kept warm after cooking with the MY RICE menu setting or after the CANCEL button was pressed.
- Feedback cannot be entered during Keep Warm if the rice was cooked using a menu setting other than MY RICE.
- Once the texture preferred by your family has been reached, it is not necessary to enter any more feedback.
- To reset to default set the Inner Cooking Pan and insert the Power Plug into an electrical outlet, then press and hold the MY RICE button for 3 seconds or longer. **CLR** appears in the Display and the Notification Sound beeps (3 long beeps), and the setting is reset to default.
- If you enter the wrong feedback or want to start over, press the CANCEL button and then start from Step 1 of “ENTERING FEEDBACK” again.

KEEPING RICE WARM

REGULAR KEEP WARM AND EXTENDED KEEP WARM

You can choose the Regular Keep Warm mode or Extended Keep Warm mode by pressing the KEEP WARM button while the KEEP WARM light is on.

- The Extended Keep Warm mode is not available in the following cases. The Rice Cooker will beep and automatically start the Regular Keep Warm mode.
 - MIXED, PORRIDGE, BROWN, GABA BROWN, CONGEE, STEEL CUT OATMEAL menu settings.
 - If 12 hours of Regular Keep Warm has already elapsed.
 - If the temperature of the Inner Cooking Pan is low because the Keep Warm mode has been cancelled, or power failure.

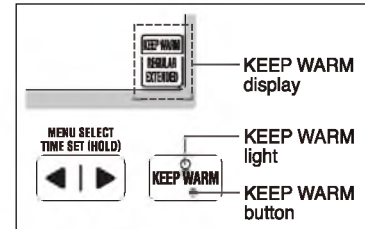

REGULAR KEEP WARM

This keeps the rice warm at a higher temperature, so the rice develops odors less easily.

When cooking completes, the Rice Cooker automatically switches to the Regular Keep Warm mode and the KEEP WARM light and KEEP WARM-REGULAR display turn on.



EXTENDED KEEP WARM

Use this function when keeping rice warm for a longer period of time. Drying and yellowing of rice will be reduced by maintaining the temperature slightly lower.

This function can be activated during the Regular Keep Warm mode.

1 Check to make sure the KEEP WARM-REGULAR display is on.



2 Press the KEEP WARM button.

The KEEP WARM-EXTENDED display will turn on.



How to change from the Extended Keep Warm mode to the Regular Keep Warm mode

Press the KEEP WARM button.



The setting will return to the Regular Keep Warm mode and the KEEP WARM-REGULAR display will turn on.

ABOUT KEEP WARM TIMES

- Be sure to observe the length of time for which rice can be kept warm as shown in the table below.
- You cannot select EXTENDED KEEP WARM for the menus marked with a "—". REGULAR KEEP WARM is automatically selected.
- After cooking, all menus default to the Keep Warm mode. However, do not use the Keep Warm mode for the menus with an "X" below. Doing so can cause spoilage and foul odors.

Menu	FIRMER•FIRM•REGULAR•SOFT•SOFTER•UMAMI•QUICK•SUSHI•MY RICE•JASMINE•QUICK JASMINE	MIXED•PORRIDGE*•JASMINE - CONGEE*•STEEL CUT OATMEAL*	BROWN•GABA BROWN
KEEP WARM			
REGULAR KEEP WARM	Up to 12 hours	X	Up to 12 hours
EXTENDED KEEP WARM	Up to 24 hours	—	—

● For each menu setting, after the time listed in the table above has elapsed, the number will begin to blink as a warning. Consume the rice as soon as possible.



● For the menus with an "X" above, the number will begin blinking at 0 hours. Do not use the Keep Warm mode for these menus.



* With PORRIDGE, CONGEE, and STEEL CUT OATMEAL, the cooked grains will become thick as time passes, so turn off the Keep Warm mode after cooking is finished and consume these foods as soon as possible.

Continued on the next page

KEEPING RICE WARM (cont.)

HOW TO KEEP RICE WARM AGAIN

■ When you want to keep rice warm after canceling the Keep Warm mode.

Press the  button.

The REGULAR KEEP WARM light turns on, and the time elapsed display returns to "0 HRS".

- If the temperatures of the rice and the Inner Cooking Pan are low, do not keep warm again. Trying to keep contents warm again when the rice and Inner Cooking Pan temperatures are low will cause "0 (HRS)" to blink.

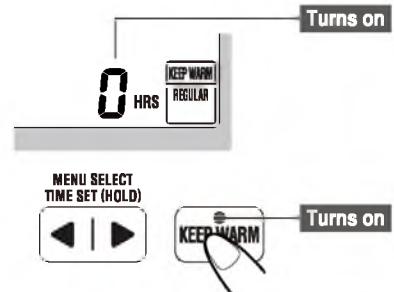

When you are concerned about the odor

- Foul odors or the growth of bacteria may occur depending on how well the unit is cleaned, the room temperature based on the season or the usage environment, frequent opening and closing of the Outer Lid, the type of rice used, or the way the rice was cleaned. If you are concerned about odors, cleaning the Rice Cooker according to "THE INTERIOR" on **pg. 28** and then using REGULAR KEEP WARM should be effective. It can be even more effective to increase the warming temperature, as described on **pg. 35**, "IF THE FOLLOWING OCCURS".

IMPORTANT

- When keeping rice in the Inner Cooking Pan for later consumption, you must use the Regular Keep Warm mode or Extended Keep Warm mode.

NOTE

- If you want to know the current time during the Regular Keep Warm mode or Extended Keep Warm mode, press the ◀ or ▶ button and the Display will switch. Press the ◀ or ▶ button again to return to the display for the Keep Warm time elapsed.

If you do not return the display to the Keep Warm time elapsed, the next time you cook rice, the Keep Warm time elapsed will not be displayed. If the Keep Warm time elapsed display is blinking, you cannot switch.

Notification Sound to Preserve the Flavor of Rice During Keep Warm

●Rice Loosening Reminder

If you did not loosen the rice promptly after it finished cooking, the Notification Sound will beep (4 short beeps) after around 10 minutes, 40 minutes, and 70 minutes. After the Rice Cooker switches to Keep Warm, open the Outer Lid and loosen the rice promptly in order to allow excess moisture to escape and prevent the rice from clumping, becoming soggy, or burnt.

●Outer Lid Close Reminder

If the Outer Lid is left open while the rice is being kept warm, the Notification Sound will beep (4 short beeps) after around 5 minutes, and thereafter will sound again 3 times at 3-minute intervals. In order to prevent the rice from drying out or becoming cold, close the Outer Lid slowly and completely until you hear it click shut.

If these reminders are not needed, you can set the Notification Sound to mute.

→ **pg. 10**

REHEATING RICE

You can use this function during the Regular Keep Warm mode or Extended Keep Warm mode.

● This Reheat function is for reheating the rice during the Keep Warm mode to make the rice hotter. Particularly, when the rice is kept warm at a lower temperature by the Extended Keep Warm mode, the Reheat function will reheat the rice to the best serving temperature.

1 Loosen and level the surface of the rice that is being kept warm.

- Be sure to loosen the rice to prevent scorching or the rice from becoming hard.
- To reheat a small amount of rice, add 1 tablespoon of water for each bowl of rice (approx. 5.5 oz./approx. 160 g), mix well, and gather the rice toward the center of the Inner Cooking Pan. Doing so will minimize dryness.
- Be careful not to burn yourself when stirring and loosening the rice.

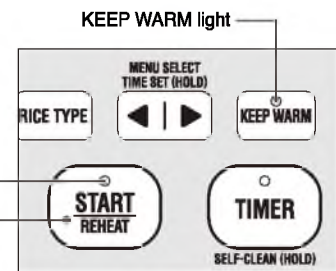

2 Make sure that the KEEP WARM light is on, and press the button.

A melody sounds, and reheating starts.

The KEEP WARM light turns off, the START/REHEAT light blinks, and the display looks like the illustration below.

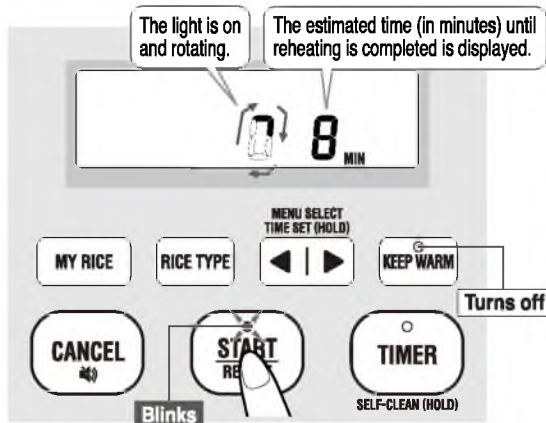

NOTE

Turns on



If you press the START/REHEAT button when the KEEP WARM light is off, the cooking process will start.

Standard times required for reheating

Approx. 4 min. – 8 min.

Approx. 4 min. – 8 min. later

The melody (beep) sounds and reheating is finished.

The START/REHEAT light turns off, the KEEP WARM light turns on, and the Rice Cooker switches to the Regular Keep Warm mode.

3 Loosen the rice.

- Loosen and level the surface of the rice, as the rice at the bottom may be harder.
- Be careful not to burn yourself when stirring and loosening the rice.

Do not reheat for the following cases

- Do not use the Reheat function to reheat food other than white rice, as reheating other types of rice may cause scorching or discoloring.
- Do not repeat the Reheat function as doing so may cause scorching or dryness.
- Do not use the Reheat function if the amount of rice left over is above Water Level Line 3 (for 1.0 L model) or 6 (for 1.8 L model) for WHITE as the rice may not be warmed adequately.
- Do not use the Reheat function if the rice is cold or the temperature of the Inner Cooking Pan is too low as doing so may cause scorching, foul odors or the rice may become hard.

To cancel the Reheat mode and return to the Keep Warm mode

Press the  button.

The START/REHEAT light turns off, the KEEP WARM light turns on, and the Rice Cooker switches to the Regular Keep Warm mode.

To cancel the Reheat mode and the Keep Warm mode

Press the  button.

The START/REHEAT light turns off, and the current time display returns.

USING THE TIMER TO COOK RICE

USING THE TIMER

- This function sets the Rice Cooker to automatically finish cooking by a specific time. Once set, the timer settings are stored in “Timer 1” or “Timer 2”.
- The initial settings are 6:00 for “Timer 1”, 18:00 for “Timer 2”.
- Set the clock to the current time before setting the Timer function. If the clock is inaccurate, the cooking will not be completed at the time you set for the Timer. → pg. 10
- If you set the Timer shorter than the Lengths for the Timer Setting (pg. 23), a beep will sound, the Rice Cooker will start cooking immediately, and the estimated time until cooking completion will be displayed. Depending on the settings, it may be possible to perform Timer cooking with the MY RICE menu setting even when the Timer is set to a time that is shorter than the Lengths for the Timer Setting.
- For pre-cooking preparations, see steps 1 through 4 under “BASIC COOKING STEPS” on pg. 11.

1 Press the button and select the type of rice.

→ See step 5 under “BASIC COOKING STEPS” on pg. 12

2 Press the or button and select the menu setting.

→ See step 6 under “BASIC COOKING STEPS” on pg. 12

- The Timer function is not available for QUICK, MIXED, and QUICK JASMINE menu settings.

Ex. When setting Timer 1 to “7:30”.
(when rice type WHITE and menu setting SOFTER are selected)

3 Press the button to select “Timer 1” (or “Timer 2”).

The preset time for “Timer 1” and the START/REHEAT light will blink.

- Press the button again and the preset time for “Timer 2” will appear.

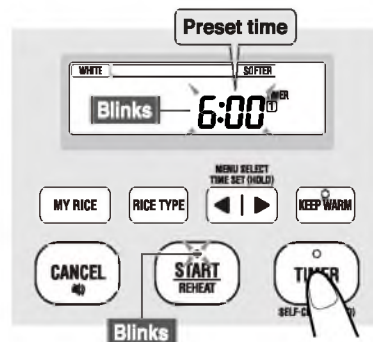

4 Press the or button to set a specific time to finish cooking.

 : Each press advances the time in 10-minute increments.

 : Each press reverses the time in 10-minute increments.

- Press and hold the button to quickly adjust the time in 10-minute increments.
- The time can only be changed when the time display is blinking.
- You do not need to set the time again when using the same settings.

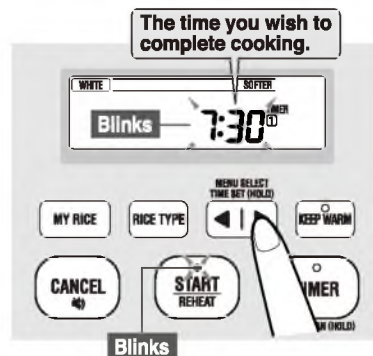

5 Press the button.

The melody (beep) sounds and the Timer setting is complete.

The START/REHEAT light turns off, and the time you wish to finish cooking and the TIMER light turn on.

- The START/REHEAT button must be pressed to set the TIMER.
- When the Outer Lid is not securely closed, the buzzer will sound (4 short beeps) to notify you. Push down on the Outer Lid slowly and securely until you hear it click shut.
- Cooking will be completed at the specified time. → See step 8 under “BASIC COOKING STEPS” on pg. 13

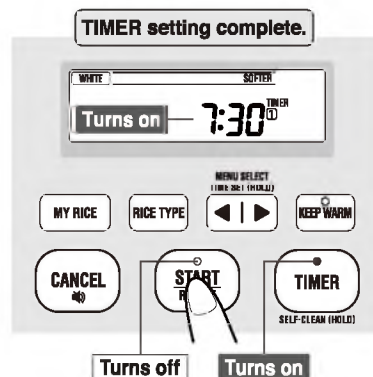

USING THE TIMER TO COOK RICE (cont.)

Lengths for the Timer Setting

- Do not set the Timer for 13 hours or more. Furthermore, do not set the Timer for 8 hours or more when the water temperature is high, such as during summer. (This will prevent spoilage caused by rice being soaked for longer than required.)

		1.0 L model	1.8 L model
FIRMER		1 hour 5 min. –	1 hour 10 min. –
FIRM		1 hour 5 min. –	1 hour 10 min. –
REGULAR		1 hour 5 min. –	1 hour 10 min. –
SOFT		1 hour 10 min. –	1 hour 15 min. –
SOFTER		1 hour 10 min. –	1 hour 15 min. –
UMAMI		1 hour 25 min. –	1 hour 30 min. –
SUSHI		1 hour 20 min. –	1 hour 20 min. –
PORRIDGE		1 hour 20 min. –	1 hour 25 min. –
MY RICE		1 hour 30 min. –	1 hour 35 min. –
JASMINE	REGULAR	1 hour 10 min. –	1 hour 15 min. –
	CONGEE	1 hour 40 min. –	1 hour 40 min. –
BROWN	REGULAR	1 hour 35 min. –	1 hour 30 min. –
	GABA	3 hours 35 min. –	3 hours 45 min. –
STEEL CUT OATMEAL		1 hour 15 min. –	1 hour 15 min. –

IMPORTANT

- Do not use the Timer function if you are adding ingredients and/or seasonings to the rice. Ingredients may spoil or seasonings may settle to the bottom of the Inner Cooking Pan and your results may not be satisfactory.

NOTE

- The estimated time until cooking completion will not be displayed when the Timer is set.
- Cooking may not complete at the set time if the temperature of the room or water is too low. In addition, the cooking time may be affected by the amount of water or voltage.
- When cooking using the Timer function, the rice absorbs extra moisture, which can make the rice softer or cause the bran to collect at the bottom and burn.
- If you want to know the current time while using the Timer function, press the ◀ or ▶ button and the Display will switch only while the button is pressed.

To cancel Timer cooking after the Timer function was set...

Press the  button.

The TIMER light turns off, the Display returns to the current time display.

RECIPES

■ The measurements used in these Recipes

- 1 Tablespoon = 0.5 oz. (15 mL)
- 1 teaspoon = 0.2 oz. (5 mL)
- Measure the rice with the provided Measuring Cup.
(1 Cup = approx. 6.1 oz./approx. 180 mL)

■ When cooking rice with additional ingredients and/or seasonings

- | | |
|--------------------|---|
| Seasonings | <ul style="list-style-type: none"> ● Seasonings should be diluted with soup stock or water and then added to the rice. After adjusting the amount of water, stir thoroughly. If the seasonings are added directly to the rice or if not mixed properly, scorching or imperfect cooking may occur. |
| Ingredients | <ul style="list-style-type: none"> ● Chop ingredients into small pieces and place evenly on top of the rice (do not mix into the rice). ● The recommended amount of ingredients should be about 30-50% of the rice volume. Excessive amount of additional ingredients may not cook properly. ● Pre-cook ingredients that do not cook easily. |

HAND-ROLLED SUSHI

Rice Selection: **WHITE**

Menu Setting: **SUSHI**

Ingredients (4-5 servings)

3 cups Rice

Mixed vinegar

- 4 Tbsp. Rice vinegar
- 1 Tbsp. Sugar
- 1 1/2 tsp. Salt

Suggested Toppings

- Sashimi (tuna, squid, prawns, etc.)
- Japanese pickles (e.g. pickled radish)
- Avocado and ham
- Natto* (fermented soybean) and green onions
- Bacon and asparagus
- Salmon roe, sea eel and rolled egg
- Carrots, cucumbers and celery

Seaweed, *wasabi* (horse radish), soy sauce and pickled red ginger to taste



How to cook

- 1 Clean rice well and fill the Inner Cooking Pan with water to Water Level Line 3 for SUSHI.
- 2 Press the RICE TYPE button to select WHITE.
- 3 Press the MENU button, select SUSHI and press the START/REHEAT button to start cooking.
- 4 When cooking is complete, place the rice into a separate

container (wiped with a clean wet cloth). Pour the mixed vinegar over the rice and mix thoroughly while cooling it with a fan.

- Hand-rolled sushi is simple and quick, wrapping your favorite sashimi, ingredients and sushi rice with *Nori* (seaweed). You can also use a lettuce leaf to wrap your hand-rolled sushi.

PAELLA

Rice Selection: **WHITE**

Menu Setting: **MIXED**

Ingredients (4-5 servings)

3 cups Rice

- 4-6 pieces (120 - 180 g) Prawns
- 4-6 pieces (200 - 300 g) clams (mussels, if available)
- 5.3 oz. (150 g) Squid
- 3 pieces (90 g) Green peppers
- 2 Tbsp. Olive oil
- 1/2 tsp. Salt

A { 1 cube Soup stock (cube)
1/2 tsp. Saffron
(1/2 tsp. Turmeric can be substituted)

How to cook

- 1 Peel and devein prawns. Remove sand from clams and wash. Cut squid into small pieces. Cut green peppers into small cubes.
- 2 Stir-fry ingredients from Step 1 with olive oil. Season with salt and cover with lid until clam shells open up. Put the ingredients aside and reserve 2 Tbsp. of the liquid.
- 3 Finely chop soup stock cubes.
- 4 Rinse rice and add water to cover the rice. Add "A" to the



Inner Cooking Pan and fill with more water to water level 3 for WHITE. Mix well from the bottom of the pan.

- 5 Press the RICE TYPE button to select WHITE.
- 6 Press the MENU button, select MIXED and press the START/REHEAT button to start cooking.
- 7 When cooking is complete, open the Outer Lid, add the ingredients from Step 2 along with the reserved liquid and mix well with the rice. Serve immediately.

RECIPES (cont.)

CONGEE

Rice Selection: **JASMINE**

Menu Setting: **CONGEE**

1.0 L model ingredients (4-5 servings)

0.5 cup Jasmine white rice
 2 cans (29 oz. (822 g)) Chicken Broth (33% reduced salt; 14.5 oz./can)
 A { 1 tsp. Sesame oil
 1/2 Tbsp. Shaoxing wine (Chinese rice wine)
 Ginger (julienne cut) as needed
 1 piece (8 g) Dried scallop meat
 Salt as needed
 White pepper as needed
 Green onion (chopped into small pieces) to taste



1.8 L model ingredients (8-10 servings)

1 cup Jasmine white rice
 4 cans (58 oz. (1644 g)) Chicken Broth (33% reduced salt; 14.5 oz./can)
 A { 2 tsp. Sesame oil
 1 Tbsp. Shaoxing wine (Chinese rice wine)
 Ginger (julienne cut) as needed
 2 pieces (16 g) Dried scallop meat
 Salt as needed
 White pepper as needed
 Green onion (chopped into small pieces) to taste

2 Place "A" on top of the ingredients from Step 1 and level the surface.

- Do not mix the ingredients with the rice. Changing the amounts of rice and ingredients may cause imperfect cooking.

3 Press the RICE TYPE button to select JASMINE.

4 Press the MENU button, select CONGEE, and then press the START/REHEAT button to start cooking.

5 When cooking is complete, season with salt and white pepper.

6 Serve in bowls and garnish with green onions as desired.

How to cook

1 Clean the jasmine white rice, add the chicken broth, pour water to 0.5 (for the 1.0 L model) or 1 (for the 1.8 L model) for CONGEE, and then mix well from the bottom of the Inner Cooking Pan.

CARROT CAKE STEEL CUT OATMEAL

Rice Selection: **STEEL CUT OATMEAL**

Ingredients (2-4 servings)

2 cups Steel cut oatmeal
 * Use the included measuring cup.
 1/4 tsp. Salt
 A { 1 1/2 tsp. Pumpkin pie spice (or cinnamon powder)
 9 fl oz. Coconut milk (canned) mixed well if hardened
 1/3 cup Honey
 1 tsp. Vanilla essence
 B { 1 cup (95 g) Carrot shredded
 2 Tbsp. Dry pineapple finely chopped
 2 Tbsp. Walnuts chopped
 1/4 tsp. Pumpkin pie spice (or cinnamon powder)
 Dry apricot (cut into cubes) to taste
 Dry pineapple (cut into cubes) to taste
 Sliced almonds (baked lightly) to taste
 Coconut flakes (baked lightly) to taste
 Cinnamon sticks to taste



How to cook

1 Put "A" into the Inner Cooking Pan, fill with water to Water Level Line 2 for STEEL CUT OATMEAL, and then mix well from the bottom of the Inner Cooking Pan.

2 Place "B" on Step 1 and level the surface.

- Do not mix the ingredients with the steel cut oatmeal. Changing the amounts of steel cut oatmeal and ingredients may cause imperfect cooking.

3 Press the RICE TYPE button to select STEEL CUT OATMEAL.

4 Press the START/REHEAT button.

5 When cooking is complete, mix well, and then serve. Coat evenly with pumpkin pie spice; sprinkle dry apricot, dry pineapple, sliced almonds, and coconut flakes to taste; and then garnish with cinnamon sticks.

CLEANING AND MAINTENANCE

- Clean the Rice Cooker thoroughly after every use.

IMPORTANT

- Be sure to unplug the Power Cord and allow the Main Body and the Inner Cooking Pan to cool down before cleaning.
- Do not use such items as thinner, abrasive cleaners, bleach, alcohol disinfectant, scrubbing brushes (nylon, metal, etc.), melamine sponges or sponges with a nylon surface. (Doing so may damage the surface, causing discoloration, scratches, degradation in quality, or corrosion.)
- Do not use a dishwasher or dish-dryer. Doing so may cause scratches, deformation or discoloration.
- Be sure to reattach the Inner Lid Set correctly.



THE EXTERIOR

Wipe clean with a well-wrung soft cloth.

- If using a cloth that is chemically treated, use sparingly to avoid transferring the chemical smell and do not scrub the Rice Cooker forcefully. (Doing so may damage the surface, causing discoloration, scratches, degradation in quality, or corrosion.)

Open Button

If the Open Button becomes clogged with rice or other matter, remove with a bamboo skewer.
● Otherwise the Outer Lid may not open.

Control Panel

Wipe with a dry soft cloth.

Exhaust Duct

(bottom front of the Main Body)

Power Plug/ Power Cord

Wipe with a dry soft cloth.

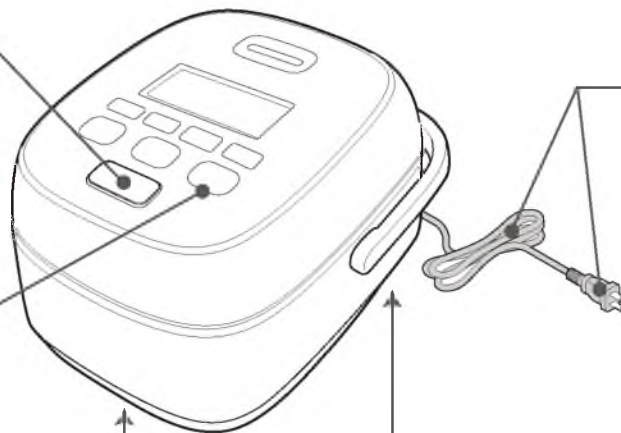

Air Intake Duct

(bottom back of the Main Body)

Clean using a vacuum cleaner (once a month).

- If you use the Rice Cooker while there is dust or other matter stuck to the Air Intake Duct or Exhaust Duct, the internal temperature may become abnormally high, resulting in breakdown.

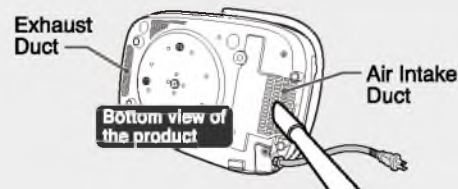

Inner Cooking Pan (→ pg. 6)/Spatula

Wash using a neutral kitchen detergent and a soft sponge.



The Nonstick Coating on the inner surface of the Inner Cooking Pan can peel off if damaged, so follow the precautions listed below.

- Do not use polishing powder, metal or nylon scrubbing brushes.
- Handle gently. Do not strike it or rub it too hard.
- When dry rice or other food has stuck to the Inner Cooking Pan or Spatula, soak it in water until the food softens, and then wash this item off with a soft sponge or something similar.

Measuring Cup

Wash using a soft sponge.

- To wash thoroughly, use a neutral kitchen detergent.



CLEANING AND MAINTENANCE (cont.)

HOW TO DETACH AND ATTACH THE INNER LID SET

HOW TO DETACH

Hold the Inner Lid Knob (①), push up the Inner Lid Set Holder (②), tilt the Inner Lid Set forward, and detach.

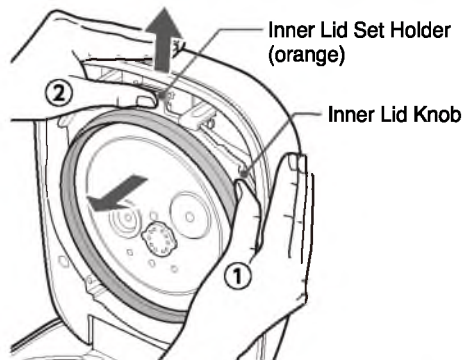

● Do not forcibly pull the Inner Lid Knobs or Inner Lid Gasket toward you without pressing the Inner Lid Set Holder. Doing so may cause the Inner Lid Set and Outer Lid to break.

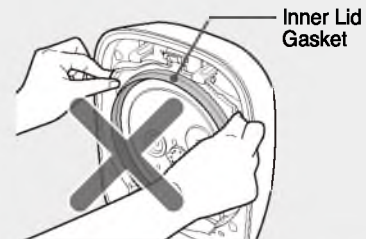

HOW TO ATTACH

- ① Line up the Inner Lid Set Fixtures (2 positions) with the arrows on the Outer Lid Fixture Holders, and then insert the Fixtures.
- ② With the Fixtures inserted, press into the Inner Lid Set Holder until you hear a click.

● Do not catch the Outer Lid Gasket on the Inner Lid Set when attaching the Inner Lid Set. Also, do not push on the Inner Lid Gasket to attach the Inner Lid Set.

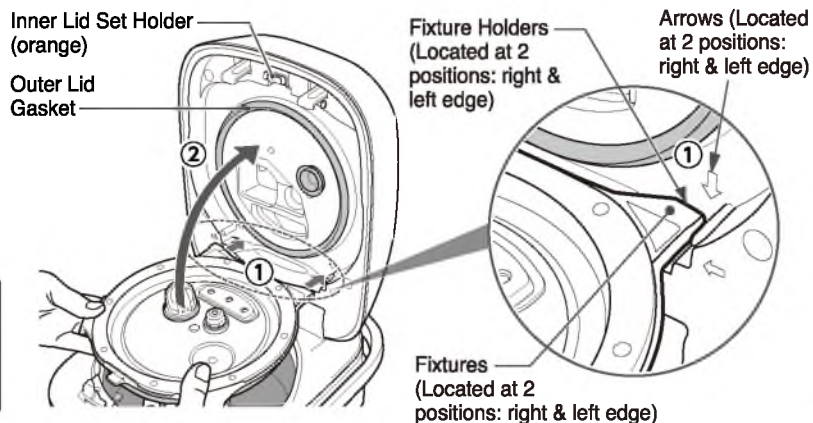

HOW TO DETACH AND ATTACH THE INNER LID FILTER

HOW TO DETACH

Turn the Inner Lid Filter in the "UNLOCK" direction and remove it from the Inner Lid Set.

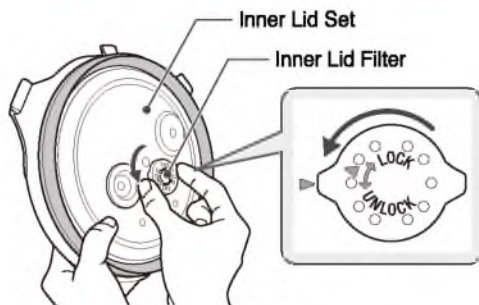

● Do not pull the Inner Lid Filter towards you. Turn it in the "UNLOCK" direction.



HOW TO ATTACH

Align the ◀ on the Inner Lid Filter and the ▶ on the Inner Lid Set, then attach the Inner Lid Filter securely by turning it in the "LOCK" direction until you hear it click.

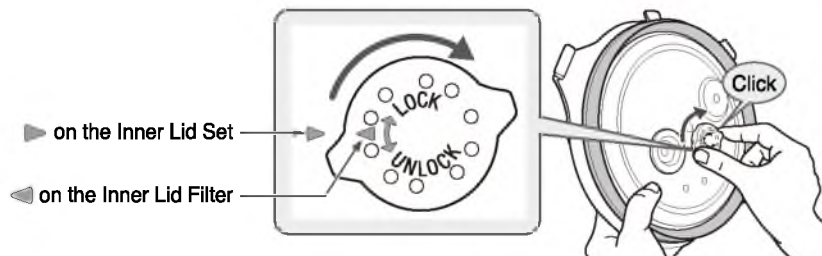

Continued on the next page

CLEANING AND MAINTENANCE (cont.)

THE INTERIOR

Safety Valve

Push the Safety Valve with your finger 2 to 3 times to make sure that it moves smoothly. If it becomes clogged with rice or other matter, remove it with a bamboo skewer.

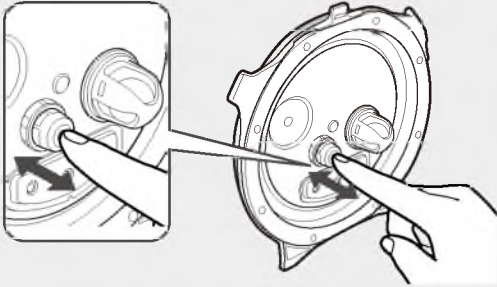

Pressure Control Valve

Push the ball inside the Pressure Control Valve with your finger to make sure it is not clogged with foreign matter. If it becomes clogged with rice or other matter, remove it with a bamboo skewer.

- Immediately after cooking or Self-Cleaning, it will be very hot and can cause burns, so please do not touch it.

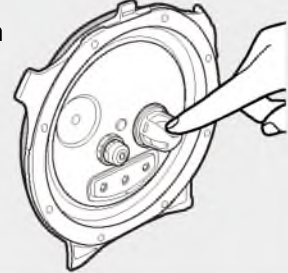

Rinse in warm or cold water, wash using a soft sponge, and wipe thoroughly dry.

- If scratched or left with rice, other matter, or moisture on the surface, brown discoloration and rusting or peeling may occur.
- Do not disassemble. Doing so may cause breakdown.

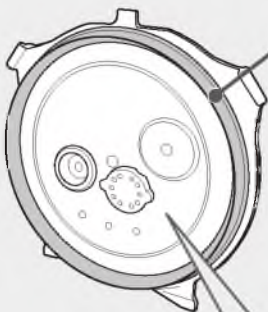

Inner Lid Gasket

- Remove rice or other matter. If not removed, steam may leak through, rice may dry, or cooking and Keep Warm may be imperfect.
- The Inner Lid Gasket cannot be removed.

Inner Lid Filter

if you notice that the filter is dirty, remove it from the Inner Lid Set and wash it using a soft sponge or something similar.

If it becomes clogged with rice or other matter, remove it with a bamboo skewer.

- HOW TO DETACH AND ATTACH THE INNER LID FILTER → pg. 27

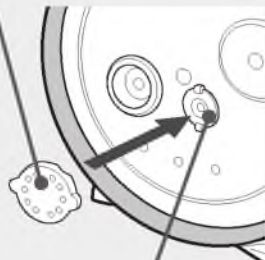

Filter Receptacle

If it becomes clogged with rice or other matter, remove it with a bamboo skewer.

Inner Lid Set

- HOW TO DETACH AND ATTACH THE INNER LID SET → pg. 27

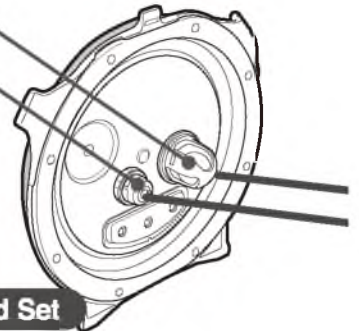

Hook Holes of the Main Body

Remove rice or other matter with a bamboo skewer.

- For safety purposes, if the Outer Lid is not closed completely, cooking or Self-Cleaning may not start, or the Outer Lid may not open.

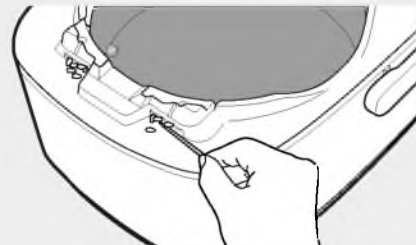

CLEANING AND MAINTENANCE (cont.)

Lid Hooks

Remove rice or other matter with a bamboo skewer.

- For safety purposes, if the Outer Lid is not closed completely, cooking or Self-Cleaning may not start, or the Outer Lid may not open.

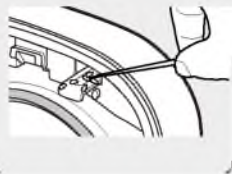

Inside of Outer Lid and Outer Lid Gasket

Wipe off any rice or residue on the inside using a well-wrung soft cloth.

- If left dirty or wet, the color may change to brown or rust may form.
- Hold the Outer Lid securely while cleaning.
- The Outer Lid Gasket cannot be removed.

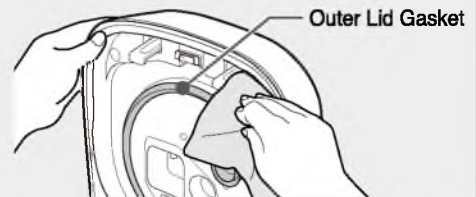

Steam Vent

Wipe off any rice or residue on the inside using a well-wrung soft cloth.

If small parts are particularly dirty, use a cotton swab or other means to remove the dirt.

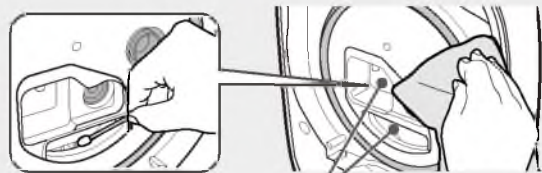

Steam Vent

Condensation Collecting Area

Wipe with a well-wrung soft cloth.

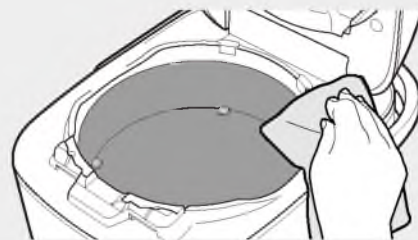

Side Sensor

(Front inside of the Main Body)

Wipe with a well-wrung soft cloth.
If it becomes clogged with rice or other matter, remove it with a bamboo skewer.



Gap Between the Main Body and Outer Lid (Shaded Area)

Wipe off stuck-on rice or other matter using a well-wrung soft cloth.

- The Outer Lid may not open if it is closed with rice or other matter left in this area.
- When there are many water drops, wipe them away.

Continued on the next page

CLEANING AND MAINTENANCE (cont.)

SELF-CLEANING

Performing Self-Cleaning using the method described below can reduce odors.
 ● However some odors cannot be completely eliminated.

1 Insert the Power Plug into an electrical outlet.

2 Put water in the Inner Cooking Pan and close the Outer Lid.

1.0 L model	Add water to the white rice Water Level Line "1"
1.8 L model	Add water to the white rice Water Level Line "2"

3 Press and hold the **TIMER** button (1.5 seconds or longer).

The Display changes to the Self-Cleaning display.

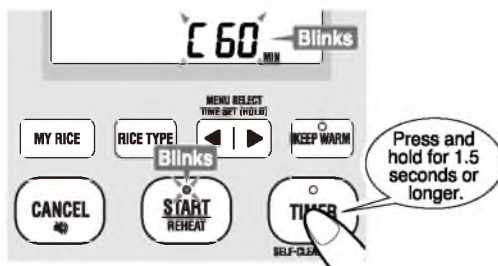

4 Press the **START/REHEAT** button.

A melody (beep) sounds, and Self-Cleaning begins. The estimated time (in minutes) until Self-Cleaning completion appears on the Display.

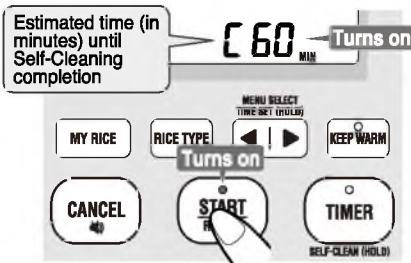

Estimated Self-Cleaning time Approx. 60 minutes

- The above table is based on the testing conditions of 120 volts, a room temperature of 68°F (20°C), and water at a starting temperature of 64.4°F (18°C).
- The estimated time until Self-Cleaning completion may differ from the actual time required. The actual time required for Self-Cleaning may vary depending on factors such as the room or water temperature, the voltage, and the amount of water.
- The Rice Cooker will make adjustments to the estimated time until Self-Cleaning completion, and the estimated time until Self-Cleaning completion may increase or decrease suddenly during this process.
- Pressure is applied during Self-Cleaning. When pressurization starts, the **(PRESSURE)** indicator on the Display turns on.
- If you want to know the current time, press the **◀** or **▶** button and the Display will switch.



5 When a melody (beep) sounds and the Display changes to a blinking "0," press the **CANCEL** button.

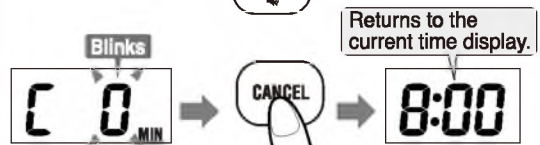

- If the CANCEL button is not pressed, the Rice Cooker will beep every 30 minutes as a reminder.
- Immediately after Self-Cleaning is completed, the Outer Lid will be tightly sealed and some time may be required before it opens.

Before opening the Outer Lid, make sure that steam is not coming out from the Steam Vent and that the **(PRESSURE)** indicator has disappeared from the Display.

6 Wait for the Main Body to cool before cleaning the Rice Cooker.

The inside will be hot. Be sure to dispose of the hot water after the Main Body has cooled down, and then clean the Rice Cooker.

To cancel Self-Cleaning before it is completed...

Press and hold the **CANCEL** button for 1 second or longer.

The START/REHEAT light turns off, and the current time display returns.

- Be cautious of the Steam Vent as steam will be forced out.

If you still notice an odor even after Self-Cleaning...

- Perform Self-Cleaning again. When performing Self-Cleaning multiple times in succession, put new water in the Inner Cooking Pan and allow the Rice Cooker to cool with the Outer Lid open for at least 50 minutes before starting. Performing Self-Cleaning without first allowing the Rice Cooker to cool may lead to an error or a longer cleaning time (up to approximately 60 minutes). Also, the estimated time until Self-Cleaning completion may not be displayed for some time in this situation.
- Performing Self-Cleaning will reduce odors, however some odors cannot be completely eliminated.

IMPORTANT

- Do not use perform Self-Cleaning when there is no water in the Inner Cooking Pan.
- Never put any substance other than water (such as detergent) in the Inner Cooking Pan.
- When performing Self-Cleaning, do not add more than the prescribed amount of water (white rice Water Level Line "1" for the 1.0 L model, or white rice Water Level Line "2" for the 1.8 L model). (Adding too much water may prevent Self-Cleaning from working properly.)
- Steam will be forced out of the Steam Vent during Self-Cleaning. Be careful to avoid getting burned.
- After Self-Cleaning, if the Outer Lid is opened while the inside is still hot, a large amount of hot steam will come out. Be careful to avoid getting burned.

TROUBLESHOOTING GUIDE

● Please check the following points before calling for service.

Problems		Possible Causes/Solutions
CONDITION OF RICE	Rice cooks too hard or too soft	<ul style="list-style-type: none"> ● Increase or decrease water slightly (by 1-2 mm) from the Water Level Line according to your preference. ● If the amount of water is adjusted with the Rice Cooker on a tilted surface, the amount of water may be too high or too low, which will lead to changes in the hardness of the cooked rice. ● The texture of rice varies depending on the brand of the rice, where it was harvested, and how long it was stored (new crop or old crop). ● The texture of rice varies depending on the room and water temperatures. ● Using the Timer may result in softer rice. ● Using the QUICK menu setting may result in harder or wet rice. → Please try using the WHITE (REGULAR), MY RICE, or UMAMI menu setting. ● Make sure the Inner Cooking Pan is not deformed. ● Rice may not have been cleaned sufficiently, leaving too much bran on the rice. ● Did you level the surface of the rice before cooking? ● Did you loosen the rice after cooking was completed? → Loosen the rice immediately after cooking is completed. ● Is there moisture or foreign matter such as (cooked or uncooked) rice on the bottom of the Inner Cooking Pan or the Side Sensor? → Wipe them off. ● Is there moisture or foreign matter on the inside of the Main Body or the Inner Lid Set? → Wipe them off. ● JASMINE white rice may be slightly harder than normal. → To make it softer, fill the water slightly higher than the Water Level Line on the inner Cooking Pan (to a point within half the distance to the next Water Level Line) and cook. However, please note that adding too much water may cause it to boil over.
	Rice is scorched	<ul style="list-style-type: none"> ● Is there moisture or foreign matter such as (cooked or uncooked) rice on the bottom of the Inner Cooking Pan or the Side Sensor? → Wipe them off. ● Rice may not have been cleaned sufficiently, leaving too much bran on the rice. ● If you soak the rice for a long time or cook rice using the Timer, the bran may collect at the bottom, and the rice will be more easily scorched. ● Make sure the Inner Cooking Pan is not deformed. ● Are you using alkaline water?
	The surface of the cooked rice is uneven	<ul style="list-style-type: none"> ● Depending on the heat convection while cooking, the surface of the cooked rice may look uneven. ● Did you level the surface of the rice before cooking? ● Make sure the Inner Lid Set and the Inner Cooking Pan are not deformed.
	During Keep Warm, rice has an odor, or rice becomes watery	<ul style="list-style-type: none"> ● Was the rice kept warm with the Spatula left in the Inner Cooking Pan? ● Was cold rice reheated? ● Did you loosen the rice after cooking was completed? → Loosen the rice immediately after cooking is completed. ● Rice may not have been cleaned sufficiently, leaving too much bran on the rice. ● Some odor may remain after cooking mixed rice. → Clean the Inner Cooking Pan thoroughly and perform "SELF-CLEANING" on pg. 30 ● The Keep Warm mode may not have been used for keeping rice warm. → Leaving rice in the Inner Cooking Pan without using the Keep Warm mode may cause unwanted odor. → pg. 9 ● Was the Extended Keep Warm mode used for 24 hours or more? (This may differ depending on the Menu setting.) → pg. 19 ● Did you clean the Rice Cooker thoroughly after every use? → Foul odors due to the growth of bacteria may occur depending on how well the unit is cleaned, the room temperature based on the season or usage environment, frequent opening and closing of the Outer Lid, the type of rice used, or the way the rice was cleaned. If you are concerned about odors, cleaning the Rice Cooker according to "THE INTERIOR" on pg. 28 and then using REGULAR KEEP WARM on pg. 19 should be effective. It can be even more effective to increase the Keep Warm temperature, as described on pg. 35, "IF THE FOLLOWING OCCURS".
	During Keep Warm, rice becomes yellow or dry	<ul style="list-style-type: none"> ● Is there moisture or foreign matter such as (cooked or uncooked) rice on the bottom of the Inner Cooking Pan or the Side Sensor? → Wipe them off. ● Are you keeping warm a small amount of rice in the Inner Cooking Pan? ● Was the Regular Keep Warm mode used for 12 hours or more or the Extended Keep Warm mode used for 24 hours or more? (This may differ depending on the Menu setting.) → pg. 19 ● Certain types of rice and water used may make the rice appear yellow. ● If you are concerned about the rice becoming yellow or dry, see pg. 35 "IF THE FOLLOWING OCCURS". It may be effective to reduce the Keep Warm temperature.
COOKING RICE	Boils over while cooking	<ul style="list-style-type: none"> ● Did you use the wrong Menu setting or amount of water? → pg. 15 - pg. 16 When cooking using the PORRIDGE, CONGEE, or STEEL CUT OATMEAL menu setting, the contents are particularly likely to boil over, so be sure not to use the wrong amount of water. → See "Be careful that the contents do not boil over." on pg. 14 ● Rice may not have been cleaned sufficiently, leaving too much bran on the rice. ● Make sure the Inner Cooking Pan is not deformed.

Continued on the next page

TROUBLESHOOTING GUIDE (cont.)

Problems	Possible Causes/Solutions
<p>COOKING RICE/ SELF-CLEANING</p> <p>Unable to start cooking or Self-Cleaning or the buttons do not respond</p>	<ul style="list-style-type: none"> ● Make sure the Power Plug is plugged in securely. ● Does the Display show “E01” or “E02” ? → pg. 36 ● Was the Inner Cooking Pan inserted correctly? → Set the Inner Cooking Pan correctly. ● Is the KEEP WARM light on? → Press the CANCEL button and press the START/REHEAT button. ● Is the Outer Lid closed securely? → Push down on the Outer Lid securely until you hear it click shut. ● Foreign matter such as rice may be stuck to the Hook Holes of the Main Body. → Remove it with a bamboo skewer and push down on the Outer Lid until you hear it click shut. ● Cooking cannot be started by pressing the MY RICE button. → Press the START/REHEAT button. ● Did you press the START/REHEAT button after selecting cooking or Self-Cleaning on the display panel? → The START/REHEAT button must be pressed to start cooking or Self-Cleaning.
<p>Steam comes out from the gap between the Outer Lid and the Main Body</p>	<ul style="list-style-type: none"> ● Make sure that the Inner Lid Set has not been dropped or deformed, and that the Inner Lid Gasket is not torn. ● Make sure that the Pressure Release Ball in the Pressure Control Valve is not stuck and can move freely. ● Has the Inner Lid Gasket become soiled? → Clean the Inner Lid Gasket. ● Make sure the Outer Lid Gasket is not caught on Inner Lid Set. → Reattach the Inner Lid Set correctly. ● Are the holes of the Safety Valve or Inner Lid Filter clogged or is there foreign matter stuck in them? → Clean the Safety Valve or Inner Lid Filter. ● Make sure the Inner Cooking Pan is not deformed.
<p>COOKING RICE/ KEEP WARM/ SELF-CLEANING</p> <p>A noise is heard during cooking, Keep Warm, or Self-Cleaning</p>	<ul style="list-style-type: none"> ● The noise is the microprocessor (MICOM) adjusting the heat power of the Rice Cooker. ● The rotary noise is the internal fan operating to release excess heat. ● The low noise is the pressure level being controlled during cooking or Self-Cleaning. ● The mechanical noise is the sound of the device that controls the pressure level during cooking or Self-Cleaning. ● The rolling noise is the movement of the Pressure Release Ball in the Pressure Control Valve, controlling the pressure level during cooking or Self-Cleaning. ● The hissing sound from pressure being released may be heard when rice completes cooking or Self-Cleaning. ● The mechanical noise and rolling noise heard immediately after cooking or Self-Cleaning is initiated or when the Timer is set are for making sure the Outer Lid is closed securely. ● The whistling noise warns that the Pressure Control Valve or Safety Valve is clogged. A louder noise may be heard when pressure is released. → Press and hold the CANCEL button for more than 1 second to cancel cooking or Self-Cleaning. The pressure inside the Inner Cooking Pan may become too high because of the clogged Pressure Control Valve or Safety Valve. (If this happens, be cautious of the Steam Vent as steam will be forced out.) Clean the Inner Lid Set and Outer Lid after the (PRESSURE) indicator disappears from the Display.
<p>The Reheat function does not work</p>	<ul style="list-style-type: none"> ● Make sure the KEEP WARM light is not off. → pg. 21
<p>KEEP WARM</p> <p>Extended Keep Warm is not accepted</p>	<ul style="list-style-type: none"> ● Did you select a menu setting for which the Extended Keep Warm mode is not available? → pg. 19 ● Was the Keep Warm mode used for more than 12 hours? → If the Keep Warm mode is used for more than 12 hours, the Extended Keep Warm mode will not be accepted. ● Is the rice in the Inner Cooking Pan cold? → If the temperature of the Inner Cooking Pan is low, the Extended Keep Warm mode will not be accepted.
<p>The Display does not show the elapsed Keep Warm time</p>	<ul style="list-style-type: none"> ● Does the Display show the current time? → Press the Time Setting buttons to change the display. → pg. 20 “NOTE”.
<p>Beeps sound during the Keep Warm mode</p>	<ul style="list-style-type: none"> ● Did you loosen the rice after it finished cooking? (The Rice Loosening Reminder sounds. → pg. 20) → Loosen the rice and close the Outer Lid. ● Is the Outer Lid open? (The Outer Lid Close Reminder sounds. → pg. 20) → Close the Outer Lid.
<p>The Keep Warm elapsed time display is blinking</p>	<ul style="list-style-type: none"> ● If the temperature of the rice is low, or if the Keep Warm time has exceeded 12 hours for the Regular Keep Warm mode or 24 hours for the Extended Keep Warm mode, the Keep Warm elapsed time will blink. (This may differ depending on the Menu setting.) → pg. 19

TROUBLESHOOTING GUIDE (cont.)

Problems	Possible Causes/Solutions
TIMER COOKING	<p>The Rice Cooker starts cooking immediately after the Timer is set</p> <ul style="list-style-type: none"> ● Is the current time set correctly? → The clock is displayed in 24-hour (military) time. Please check and set it again. ● If the Timer is set to a time that is less than the timer cooking times, the Rice Cooker will begin cooking immediately. → pg. 23 Lengths for the Timer Setting Times
	<p>Rice is not ready at the set time</p> <ul style="list-style-type: none"> ● Is the current time set correctly? → The clock is displayed in 24-hour (military) time. Please check and set it again. ● Cooking may not complete at the set time if the temperature of the room or water is too low. In addition, the cooking time may be affected by the amount of water or voltage.
	<p>The Timer cannot be set</p> <ul style="list-style-type: none"> ● Did you press the START/REHEAT button after setting the time? → The START/REHEAT button must be pressed to complete setting the Timer. ● Is “7:00” blinking on the Display? → Unless the current time is set, the Timer function will not be accepted. → pg. 10 ● Is the Outer Lid closed securely? → Close the Outer Lid securely. ● Foreign matter such as rice may be stuck to the Hook Holes of the Main Body. → Remove it with a bamboo skewer and push down on the Outer Lid securely until you hear it click shut. ● Have you selected a Menu setting that doesn’t work with the Timer function? → The Timer function is not available for QUICK, MIXED, and QUICK JASMINE menu settings.
OTHER	<p>The Display (LCD display) is off</p> <ul style="list-style-type: none"> ● Is the Power Plug unplugged from the electrical outlet? ● Is there a power failure?
	<p>The Display (LCD display) is cloudy</p> <ul style="list-style-type: none"> ● The Display may become cloudy when the Rice Cooker was not used for a prolonged period, or due to temperature changes in the surrounding environment. ● Has the Inner Cooking Pan exterior been wiped dry before placing inside the Main Body? → If the Inner Cooking Pan exterior is wet when placed in the Main Body, water may enter inside the Main Body and cause it to malfunction or the Display to become cloudy. ● Does the cloudiness disappear when cooking or keeping rice warm? → If the cloudiness disappears when cooking or keeping rice warm, it may be due to condensation caused by the temperature difference between the inside of the Main Body and the room temperature. Please continue to use the product, as it will improve after cooking rice several times. If the Display becomes cloudier or water accumulates after using several times, water may have entered inside the Main Body. An examination and repair are required if this occurs. Please contact the store where you purchased the Rice Cooker or Zojirushi Customer Service.
	<p>The Outer Lid won’t close or is difficult to close</p> <ul style="list-style-type: none"> ● Is rice or other foreign matter stuck to the area around the Lid Hooks, the Hook Holes of the Main Body, between the Main Body and the Outer Lid, on the Inner Lid Gasket, the Pressure Control Valve, the Safety Valve, or the Steam Vent? → Remove the foreign matter. → pg. 28 - pg. 29 ● In order to allow high-pressure rice cooking, the gaskets are extremely airtight. When closing the Outer Lid, you may feel resistance. Push down on the Outer Lid slowly and securely until you hear it click shut. ● Is the Inner Lid Set attached correctly? → If the Inner Lid Set is not attached when the Inner Cooking Pan has been placed inside the Main Body, the Outer Lid will not close for safety purposes. This is not a malfunction.
	<p>The Outer Lid cannot be opened</p> <ul style="list-style-type: none"> ● The Outer Lid is locked during high-pressure rice cooking or Self-Cleaning and cannot be opened. If it is necessary to open the Outer Lid during cooking or Self-Cleaning, press and hold the CANCEL button for 1 second or longer. → See “IMPORTANT” on pg. 14. ● If you press the edge of the Open Button, the Outer Lid may be difficult to open. Be sure to press the center of the Open Button.
	<p>The Outer Lid opens during cooking or Self-Cleaning</p> <ul style="list-style-type: none"> ● Did you close the Outer Lid completely? → Be sure to close the Outer Lid until you hear it click shut.
<p>There is a sound when opening or closing the Outer Lid</p> <ul style="list-style-type: none"> ● The rattling sound you hear when opening and closing the Outer Lid is the sound of the Pressure Release Ball moving. 	

Continued on the next page

TROUBLESHOOTING GUIDE (cont.)

Problems	Possible Causes/Solutions
OTHER	<p>There is water dripping from the bottom of the Main Body</p> <ul style="list-style-type: none"> ● Is there water accumulated in the Condensation Collecting Area or between the Main Body and Outer Lid? → When a certain amount of water accumulates in the Condensation Collecting Area or between the Main Body and Outer Lid, the structure causes the water to drain from the bottom of the Main Body. If there is accumulated water, fully wipe it away.
	<p>When power failure occurs</p> <ul style="list-style-type: none"> ● If too many appliances are used simultaneously while cooking or Self-Cleaning is in progress, an overload may occur and the breaker will cut off the electricity. → If another appliance is plugged into the same electrical outlet as the Rice Cooker, unplug it before resetting the breaker. If the electricity is restored within 10 minutes, the Rice Cooker will resume cooking or Self-Cleaning automatically.
	<p>There's a resinous odor, such as that of plastic</p> <ul style="list-style-type: none"> ● When you use this Rice Cooker for the first time, there will be a resinous smell, such as that of plastic, but the odor will lessen as you use the Rice Cooker. If you are concerned about the odor, please see pg. 30 "SELF-CLEANING".
	<p>You mistakenly put rice and water directly into the Main Body</p> <ul style="list-style-type: none"> ● Putting rice and water directly into the Main Body may cause a malfunction. Contact the store where you purchased the Rice Cooker or Zojirushi Customer Service.
	<p>Sparks from the Power Plug</p> <ul style="list-style-type: none"> ● There may be sparks when plugging in or unplugging the Power Plug from the electrical outlet. This is common in IH rice cookers, and does not indicate a malfunction.
	<p>The estimated time until cooking or Self-Cleaning completion is not displayed</p> <ul style="list-style-type: none"> ● If cooking or Self-Cleaning is performed consecutively, the estimated time will not be displayed until the Main Body cools down, but the rice cooking or Self-Cleaning will start. This is not a malfunction.
	<p>There is rust colored dirt on the inside of the Outer Lid or the Inner Lid Set</p> <ul style="list-style-type: none"> ● If rice residue is stuck on the Outer Lid or the Inner Lid Set and has discolored, clean it. → pg. 28 - pg. 29

REPLACEMENT PARTS

- Please replace damaged parts for optimum performance.
- When replacing parts, please check the model number and the parts name beforehand, then contact the store where you purchased the Rice Cooker or Zojirushi Customer Service.

Zojirushi Customer Service
1-800-733-6270
www.zojirushi.com

Part Name		Part Number
Inner Lid Set	1.0 L model	C241-GR
	1.8 L model	C242-GR
Inner Cooking Pan	1.0 L model	B623-6B
	1.8 L model	B624-6B
Inner Lid Filter		BU354025L-01
Spatula		BE868212L-02
Measuring Cup		615784-00

IF THE FOLLOWING OCCURS

When you are concerned about foul odors, color changes or dryness in the rice...

Change the Keep Warm temperature.

Depending on the region or environment, the rice may produce an odor, or become discolored or dried out. If this is not improved with the Regular Keep Warm mode or Extended Keep Warm mode, try changing the Keep Warm temperature settings as follows.

● REGULAR KEEP WARM and EXTENDED KEEP WARM will change at the same time.

■ How to Change the Keep Warm Temperature Settings

1 Set the Inner Cooking Pan and insert the Power Plug into an electrical outlet.

7:00

The current time is displayed.

2 Press and hold the RICE TYPE button for 3 seconds or longer.

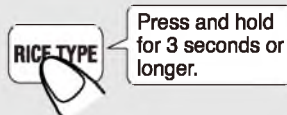

You will hear 3 beeps and the current setting will blink. (Default setting is "0".)

3 Press the ◀ or ▶ to set the temperature.

If you press the ▶, the setting changes in the direction of the →.

If you press the ◀, the setting changes in the direction of the ⇨.

Range of Keep Warm Temperature	-3	-2	-1	0	1	2	3
	Low	←		Default setting		→	High

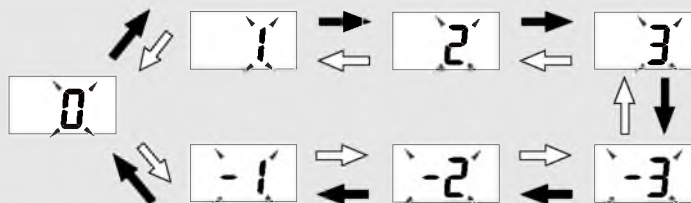

If you are worried about odors in the rice, select [1] – [3] to increase the Keep Warm temperature. If you are worried about changes in color or dryness in the rice, select [-1] – [-3] to decrease the Keep Warm temperature.

4 Press the RICE TYPE button.



3

The setting is saved when the setting stops blinking and you hear 3 beeps.

After the beeps, the display returns to the current time.

7:00

NOTE

- Settings cannot be changed during cooking, reheating, Regular Keep Warm, Extended Keep Warm, timer cooking, or Self-Cleaning.
- If you are unable to successfully complete the operation the first time, start again from Step 1.
- Once you change the setting, that setting will be saved even if you unplug the Power Plug from the electrical outlet.
- If 15 seconds or more elapse without any action while you are changing the setting, the display will revert to the current time and the setting will not be changed.

If there is no improvement after you change the Keep Warm temperature setting, return it to the original setting, as the changed setting may cause odors, color changes or dryness.

ERROR DISPLAYS AND THEIR MEANINGS

If the countermeasures listed below do not solve the problem, contact the store where you purchased the Rice Cooker or Zojirushi Customer Service.

Panel Display	Cause (Points to check)
E 06	<ul style="list-style-type: none"> ● In case of voltage abnormality, the unit automatically stops to prevent a breakdown. → Recheck the rated voltage of the outlet to see if it complies with the Rice Cooker. If not, use another outlet.
E 17 H 17	<ul style="list-style-type: none"> ● The Outer Lid is not completely closed. → Press the CANCEL button, make sure that the Outer Lid is completely closed, and then press the START/REHEAT button. If this does not solve the problem, please contact the store where you purchased the Rice Cooker or Zojirushi Customer Service.
H 01 H 02	<ul style="list-style-type: none"> ● The temperature of the Lid Sensor or the Side Sensor is too high. → Press the CANCEL button and open the Outer Lid for more than 50 minutes and allow the interior to cool down. (Be careful not to burn yourself.) To cool faster, see pg. 14.
H 04	<ul style="list-style-type: none"> ● The Inner Cooking Pan is not inserted. → Set the Inner Cooking Pan securely.
 The Display is blank	<ul style="list-style-type: none"> ● Is the Power Plug unplugged from the electrical outlet? → The Display turns off when the Power Plug is not connected.
7:00 blinks when the Power Plug is connected	<ul style="list-style-type: none"> ● The built-in lithium battery is dead. The Display will turn off and stored information (current time, menu selection, and Keep Warm settings) will be erased when the Power Plug is unplugged from the electrical outlet. However, the Rice Cooker will function normally once the Power Plug is connected and the time is set. If rice is cooked while the display shows a blinking 7:00, the current time will not be shown during the cooking process. → Contact Zojirushi Customer Service to have the lithium battery replaced (a fee will be charged for the replacement).
PRESSURE is blinking	<ul style="list-style-type: none"> ● The Rice Cooker has stopped cooking while there is still pressure inside. Please wait until the PRESSURE indicator disappears from the Display (approx. 5-10 minutes.) Use of the buttons will not be accepted while the PRESSURE indicator is blinking.
Odd Display	<ul style="list-style-type: none"> ● Unplug the Power Cord and plug it in again. (If the Display shows a blinking 7:00, please reset the time.) → pg. 10
E 01 E 02 E 07 E 13 E 21	<ul style="list-style-type: none"> ● Indicates malfunction. → Please contact the store where you purchased the Rice Cooker or Zojirushi Customer Service.

Error Display

SPECIFICATIONS

Model No.		NW-JEC10		NW-JEC18		
Cooking Capacity (approx. L) [cups] *1	FIRMER, FIRM, REGULAR, SOFT, SOFTER (Short/Medium grain white rice)	0.09–1.0	[0.5–5.5]	0.18–1.8	[1–10]	
	UMAMI (Short/Medium grain white rice)	0.09–1.0	[0.5–5.5]	0.18–1.8	[1–10]	
	QUICK (Short/Medium grain white rice)	0.09–1.0	[0.5–5.5]	0.18–1.8	[1–10]	
	MIXED (Short/Medium grain white rice)	0.09–0.72	[0.5–4]	0.36–1.08	[2–6]	
	SUSHI (Short/Medium grain white rice)	0.09–1.0	[0.5–5.5]	0.18–1.8	[1–10]	
	PORRIDGE (Short/Medium grain white rice)	0.09–0.27	[0.5–1.5]	0.09–0.45	[0.5–2.5]	
	MY RICE (Short/Medium grain white rice)	0.09–1.0	[0.5–5.5]	0.18–1.8	[1–10]	
	JASMINE	REGULAR	0.09–1.0	[0.5–5.5]	0.18–1.8	[1–10]
		QUICK	0.09–1.0	[0.5–5.5]	0.18–1.8	[1–10]
		CONGEE	0.09–0.18	[0.5–1]	0.09–0.27	[0.5–1.5]
	BROWN	REGULAR (Short/Medium grain brown rice)	0.18–0.72	[1–4]	0.36–1.44	[2–8]
		GABA (Short/Medium grain brown rice)	0.18–0.72	[1–4]	0.36–1.44	[2–8]
	STEEL CUT OATMEAL		0.09–0.45	[0.5–2.5]	0.18–0.54	[1–3]
Rating		AC 120 V 60 Hz				
Electric Consumption		1240 W		1370 W		
Average Power Consumption during Keep Warm		29 W		36 W		
Rice Cooking System		PRESSURE IH System				
Power Cord Length		3' 3" (1.0 m)				
External Dimensions	<approx. inch>	10-3/4 (W) x 13-5/8 (D) x 8-1/2 (H) (17-5/8 *2)		12 (W) x 14-5/8 (D) x 9-3/4 (H) (19-3/4 *2)		
	<approx. cm>	27.5 (W) x 34.5 (D) x 21.5 (H) (44.5 *2)		30.5 (W) x 37 (D) x 24.5 (H) (50 *2)		
Weight		approx. 15 lbs. (approx. 6.5 kg)		approx. 17 lbs. (approx. 7.5 kg)		

- The average power consumption during Keep Warm is calculated with the Rice Cooker at maximum capacity and at a room temperature of 68°F (20°C).
- This product may not operate properly in certain environments or places with high altitudes or extreme weather conditions. Please avoid using this product in such areas.
- This product cannot be used in areas where power supply voltage or power supply frequency is different.
- (*1) Capacity is measured in the supplied rice measuring cup, using uncooked rice. Other grains may vary.
- (*2) Height with the Outer Lid open.

DECLARATION OF CONFORMITY WITH FCC RULES

According to 47CFR, Part 2 and 18

We, Zojirushi America Corporation,

Located at : 19310 Pacific Gateway Drive, Suite 101 Torrance, CA 90502, USA

Telephone Number : 310-769-1900

Declare under sole responsibility that the product:

Trade Name: ZOJIRUSHI

Kind of equipment: Electric Rice Cooker & Warmer

Model Name: NW-JEC10, NW-JEC18

Complies with 47CFR Part 2 and 18 of the FCC rules as a Consumer, Industrial, Scientific and medical equipment. Each product marketed, is identical to the representative unit tested and found to be compliant with the standards.

Records maintained continue to reflect the equipment being produced can be expected to be within the variation accepted, due to quantity production and testing on a statistical basis as required by 47CFR §2.909.

Operation is subject to the following two conditions: (1) This device may not cause harmful interference, and (2) This device must accept any interference received, including interference that may cause undesired operation.

The above named party is responsible for ensuring that the equipment complies with the standards of 47CFR §18.301 to 18.311.

Signature of Party Responsible:

Tatsuya Yamasaki President / CEO

Date of issue: October 26, 2021

www.zojirushi.com

FOR CALIFORNIA USA ONLY

This product contains a CR Coin Lithium Battery which contains Perchlorate Material - special handling may apply. See www.dtsc.ca.gov/hazardouswaste/perchlorate

NW-JEC(1) ©(B)(A)