



TXFBB12



**12" SWING GATE MOUNTED
SUBWOOFER ENCLOSURE
FOR FORD BRONCO**

INSTALLATION GUIDE

NOTE! Read this installation guide thoroughly before disassembling or modifying the vehicle. Installation of this product requires technical skill, experience and specialized tools. If in doubt, it's recommended to have it professionally installed by an authorized **Stinger** or **AudioControl** Dealer.

A video installation guide is available at:
<https://stingerelectronics.com/products/txfbb12>



Limited Warranty

Stinger warrants this product to be free of defects in materials and workmanship for a period of one (1) years from the original date of purchase. This warranty is not transferable and applies only to the original purchaser from an authorized Stinger dealer in the United States of America only. Should service be necessary under this warranty for any reason due to manufacturing defect or malfunction, Stinger will (at its discretion), repair or replace the defective product with new or remanufactured product at no charge. Damage caused by the following is not covered under warranty: accident, misuse, abuse, product modification or neglect, failure to follow installation instructions, unauthorized repair attempts, misrepresentations by the seller. This warranty does not cover incidental or consequential damages and does not cover the cost of removing or reinstalling the unit(s). Cosmetic damage due to accident or normal wear and tear is not covered under warranty.

INTERNATIONAL WARRANTIES:

Products purchased outside the United States of America are covered only by that country's Authorized Stinger reseller and not by Stinger. Consumers needing service or warranty information for these products must contact that country's reseller for information.

INSTALLATION NOTES

- For models equipped with a factory subwoofer, unplugging the factory subwoofer is recommended.
- Some installation steps are more easily completed with a second person.
- Speaker wire is required before the enclosure is mounted.
- Recommended amplifier rating: 200-600 watts @ 2ohms.
- Do not power up until inside contents are removed.

GETTING STARTED

Remove the four Philips screws from the speaker and remove the speaker.
Set speaker and screws in a safe place.

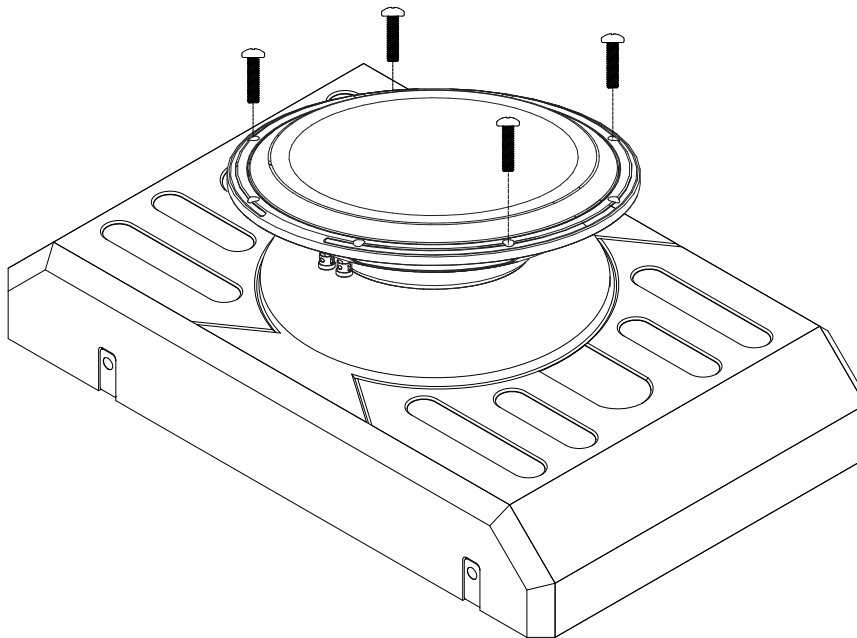

Remove contents from inside the enclosure.

Open the hardware pack and confirm hardware quantities and tools required using the guide on the following pages.

RECOMMENDED TOOLS

#2 Philips Screwdriver
5mm Allen Wrench
14mm Wrench
10mm Socket
Ratchet
Socket Extension

9mm Drill Bit (Included)
Drill
Center Punch
Hammer
Tape
Wire Strippers

Scissors
Rivet Nut Setter (Optional)

HARDWARE

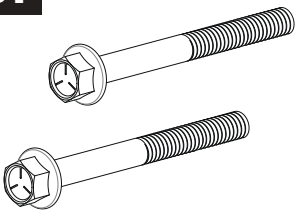
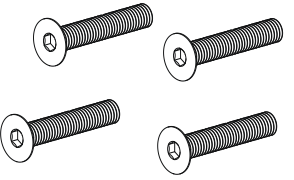
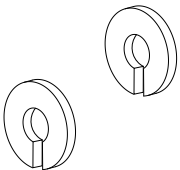
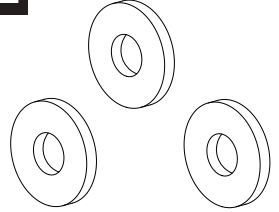
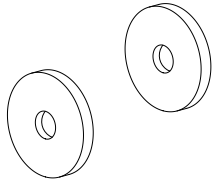
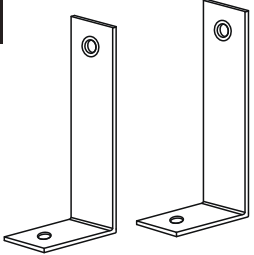
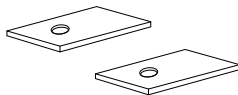
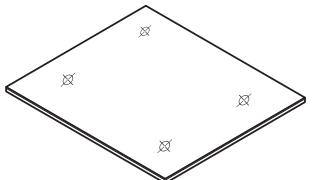
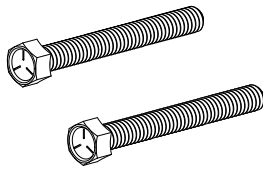
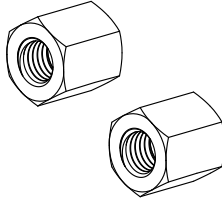
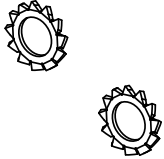
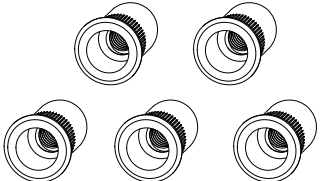
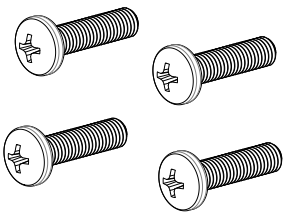
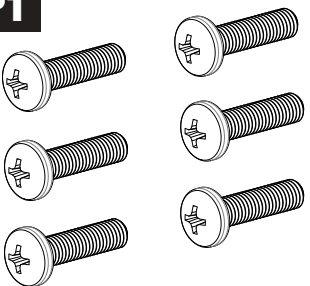
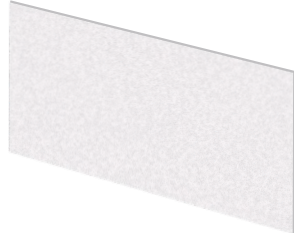
B1 	B2 	W1 	W2 
M6 FLANGED HEX HEAD BOLT (2) 40mm / 1.57in Length	M6 ALLEN HEAD BOLT (4) 20mm / .78in Length	M6 SPLIT LOCK WASHER (2) 11mm / .43in Diameter	M6 METAL WASHER (3) 18mm / .71in Diameter
W3 	L1 	L2 	T1 
M6 RUBBER WASHER (2) 18mm / .71in Length	BOTTOM L BRACKET (2)	FOAM BRACKET PAD (2)	MOUNTING TEMPLATE (1)
B3 	N1 	W4 	R1 
M6 HEX HEAD BOLT (2) 40mm / 1.57in Length	M8 HEX NUT SPACER (2)	M6 TOOTH LOCK WASHER (2)	M6 RIVET NUT INSERT (5)
P1 	P1 		
M5 PHILIPS HEAD SCREW (4) 30mm / .78in Length <i>(Removed from speaker)</i>	M5 PHILIPS HEAD SCREW (6) 30mm / .78in Length <i>(Included in hardware)</i>	POLY-FILL (1)	

NOTE: Hardware images not to scale. There will be hardware left over depending on the installation

INSTALLATION

1

Using scissors or a straight edge and utility knife, cut out the template along the dashed lines.

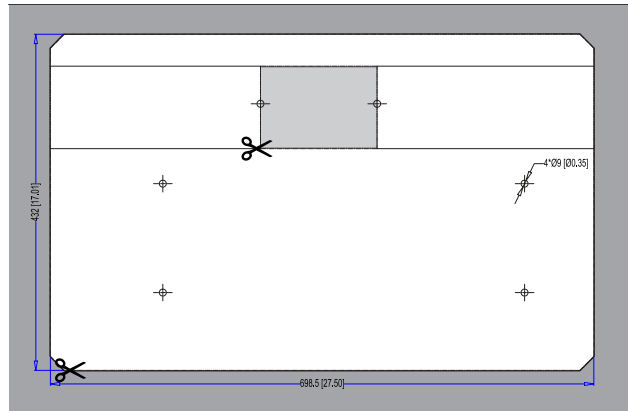

2

Position the template on the inside of the swing gate using the plastic trim panel as a guide as shown.

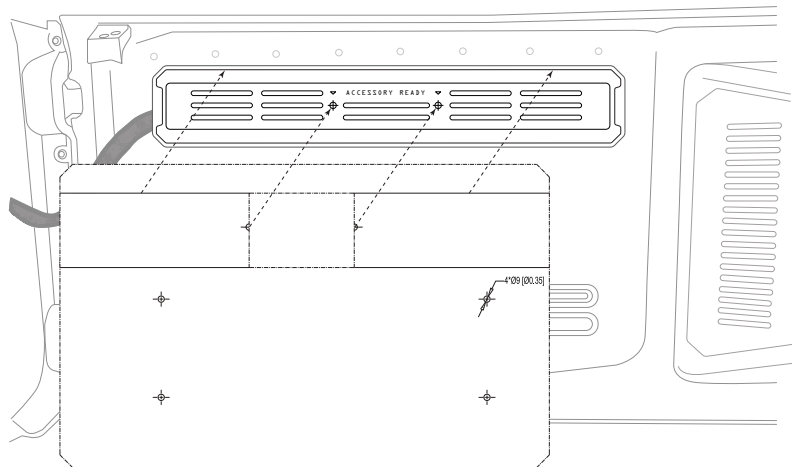

Align the left and right cross-hairs on the template to the register marks on the trim panel (1). Verify the template is straight by confirming the horizontal line on the template (2) follows the horizontal groove on the plastic trim panel.

Once aligned, securely tape the template to the swing gate.

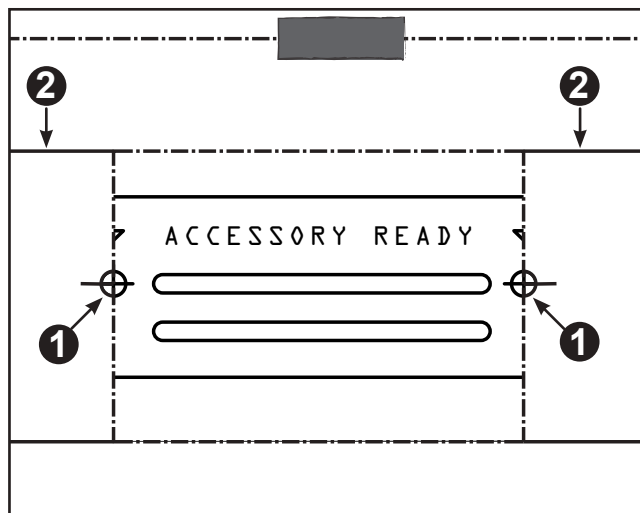

INSTALLATION

3

Using a center punch, mark the four mounting locations on the template.

Remove the template and drill pilot holes at the four locations.

CAUTION: To prevent the drill bit from hitting the outer side of the swing gate, wrap a significant amount of tape around the drill bit leaving only $\frac{1}{2}$ " of the bit exposed.

Drill 9mm holes at the four marked locations.

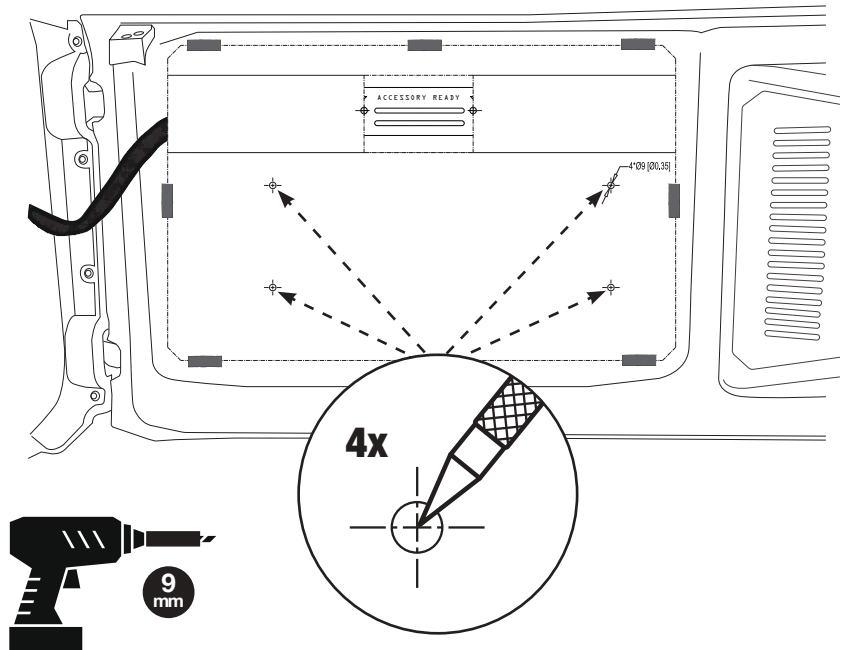

4

Remove the swing gate trim panel using a nylon panel tool or similar to release the retaining clips (1) along the bottom, then swing up (2) to release the locking tabs along the top.

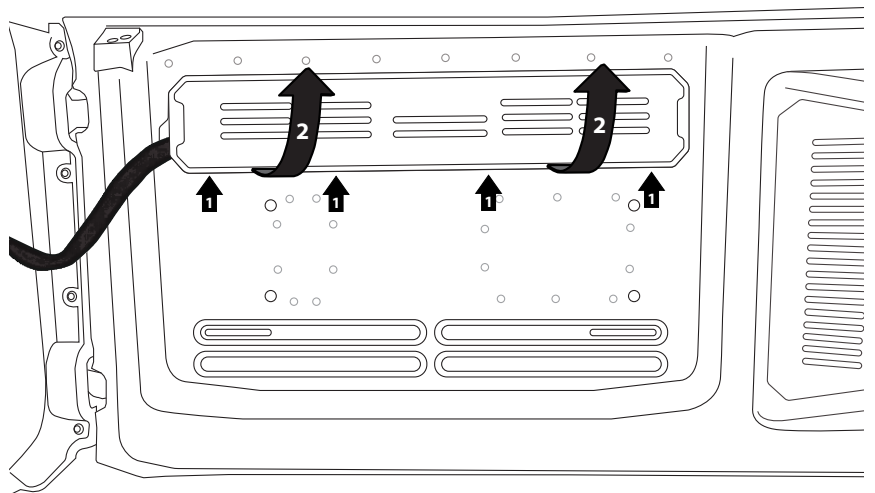

INSTALLATION

5

If a rivet nut setter is not available, follow the directions below for each of the four holes:

- A. Insert a **R1** rivet nut into the hole.
 - B. Slide an **W2** metal washer, a **N1** spacer nut and a **W4** tooth lock washer onto one of the **B3** bolts.
 - C. Hand thread the bolt into the rivet nut until it is hand tight.
 - D. Using a 14mm wrench to hold the spacer nut, start tightening the bolt with a 10mm socket.
- Ensure the the rivet nut remains fully inserted and flat against the panel surface while tightening.
- The wrench and spacer nut should be held in place; do not rotate.
- The rivet nut takes approximately 12-13 quarter turns to properly seat. The bolt will get harder to turn when the rivet nut is seated.
- E. Once installed, loosen and remove the 10mm bolt while continuing to hold the spacer nut in place with the wrench.

NOTE: After installing the first rivet nut, ensure the side of the spacer nut that was positioned against the tooth lock washer is the same for the remaining installations.

There are two bolts, spacer nuts and washers provided in the event they are needed.

TIP: Having a second person hold the wrench in place and using two hands to tighten with the ratchet will allow you to apply more forward pressure while tightening, keeping the insert flush against the panel.

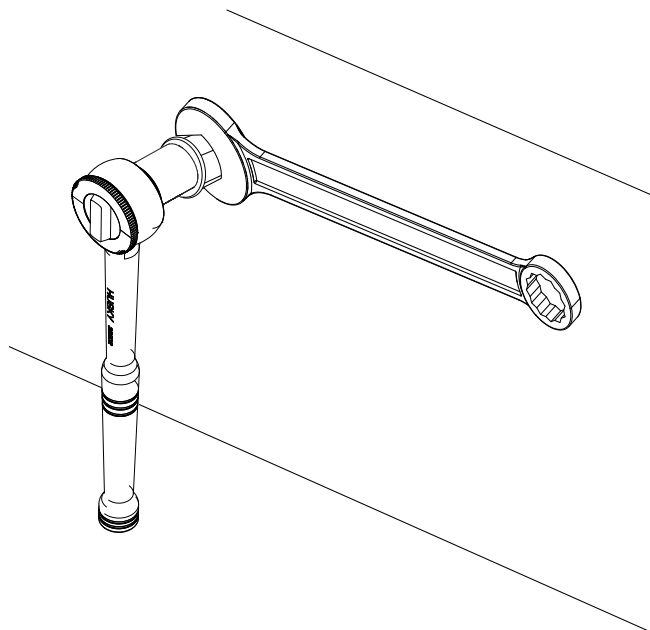
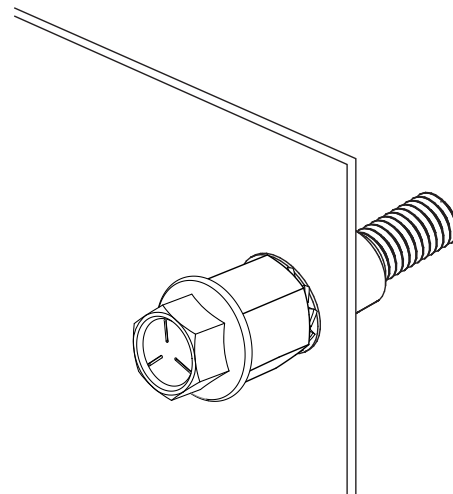
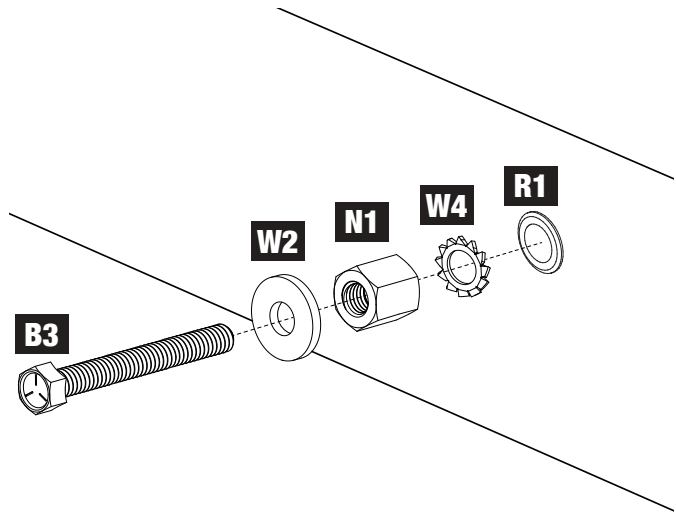

INSTALLATION

6

In the two lower threaded inserts, install **L1** brackets using **B2** allen bolts.

Apply the **L2** Foam Bracket Pads to the brackets.

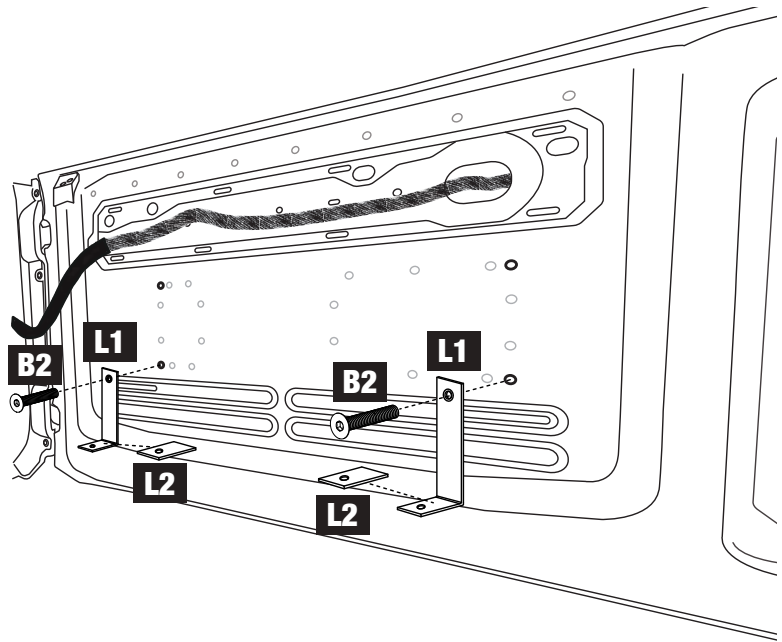

7

Run a suitable length of speaker wire into the swing gate following the factory wire harness.

Connect the speaker wire to the terminals. Positive (+) is Red and Negative (-) is Black. Route the speaker wire in the channel.

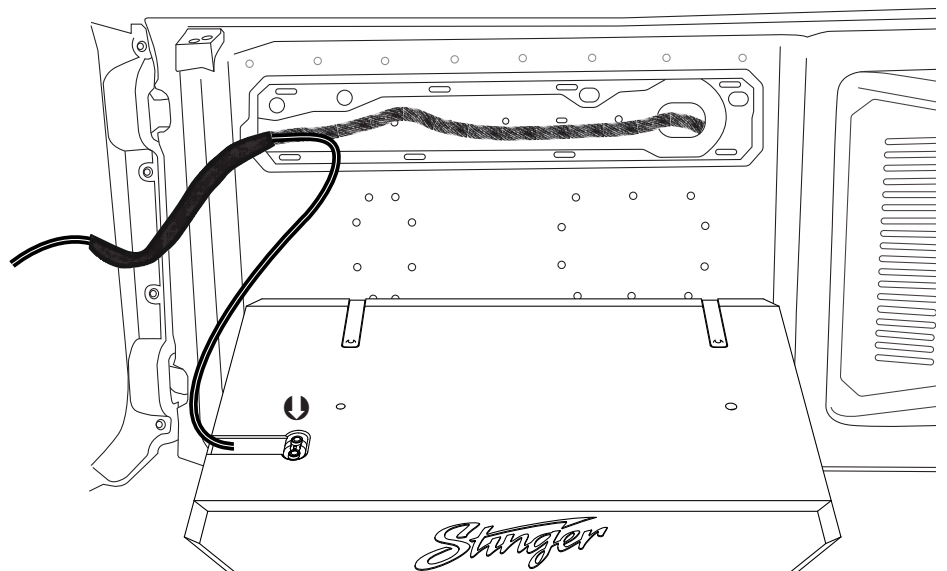

INSTALLATION

8

Align the speaker enclosure on the L Brackets. Loosely install the indicated hardware into the upper mounting holes from inside the enclosure.

Install the two **B2** Allen Head Bolts through the L Brackets and into the bottom of the enclosure.

Once all the bolts are threaded, tighten all hardware.

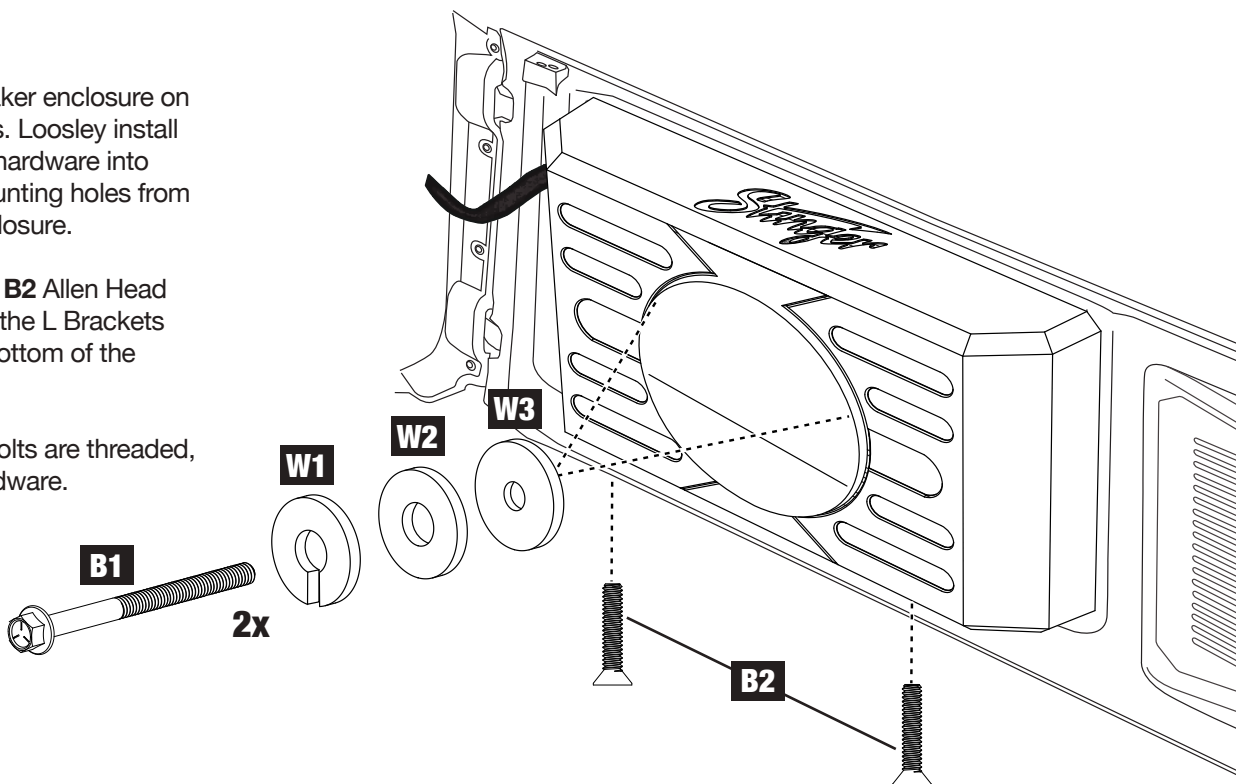

9

A. Place the sheet of poly-fill inside the enclosure along the back and side areas.

B. Connect the speaker leads inside the enclosure to either of the speaker terminals on the speaker. Positive (+) is Red and Negative (-) is Black.

NOTE: Ensure the pre-installed speaker terminal jumper wires stay connected when connecting the wires to the speaker terminal.

C. Align the speaker and install eight **P1** screws securing the speaker.

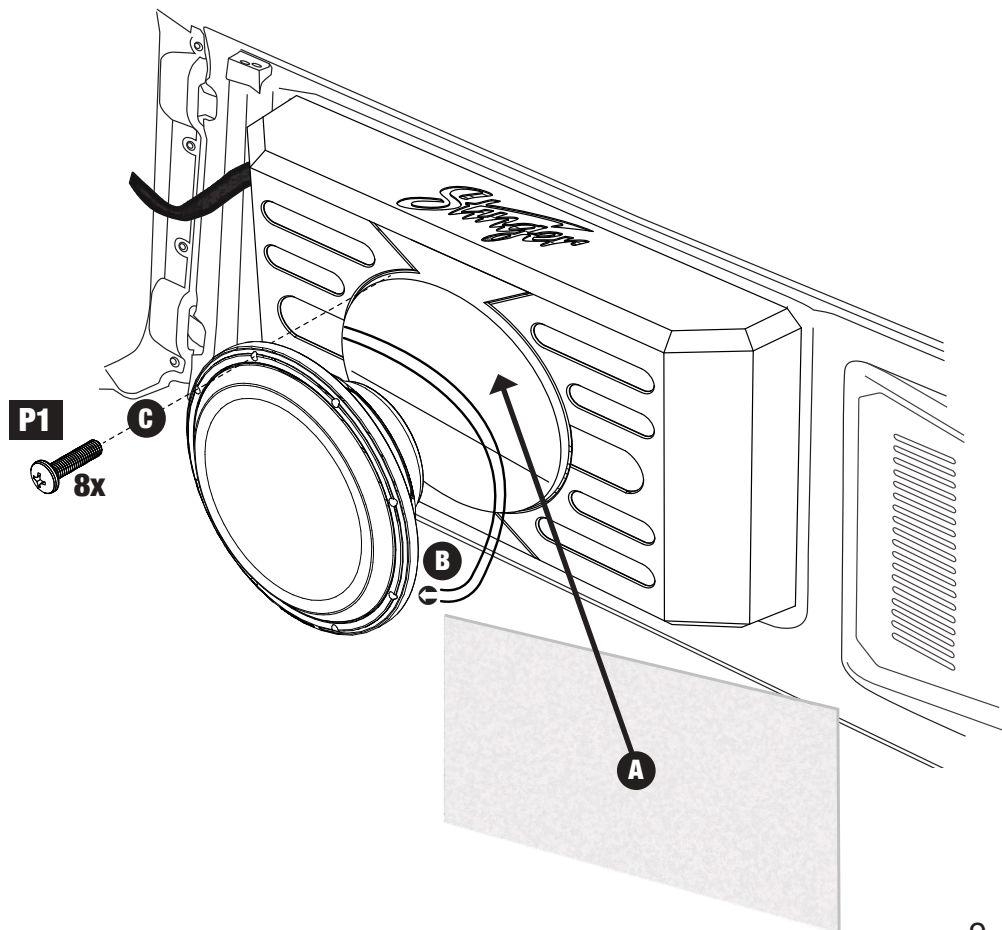

SPECIFICATIONS

Model Number	TXFBB12
Speaker Model	SPC-12S2
Subwoofer Size	12"
Voice Coil	Single 2 ohm
DC Resistance (Re)	2 ohm
Sensitivity 1W/M (SPL)	87 dB
Frequency Response	20Hz - 250Hz
RMS Power	Min 200w - Ideal 400w - Max 600w
Speaker Displacement	0.06 cu ft / 1.82 Ltr
Speaker Weight	12.5 lbs
Enclosure Specifications	
Internal Volume	0.706 cu ft. / 19.99 Ltr
Enclosure Weight	16.25 lbs
Height	17in / 43.2cm
Width	27.5in / 69.9cm
Depth	4.6in / 11.7cm
Depth (with Speaker & Grill)	5.8in / 14.7cm

Height
17in / 43.2cm

Width
27.5in / 69.9cm

Depth
4.6in / 11.7cm

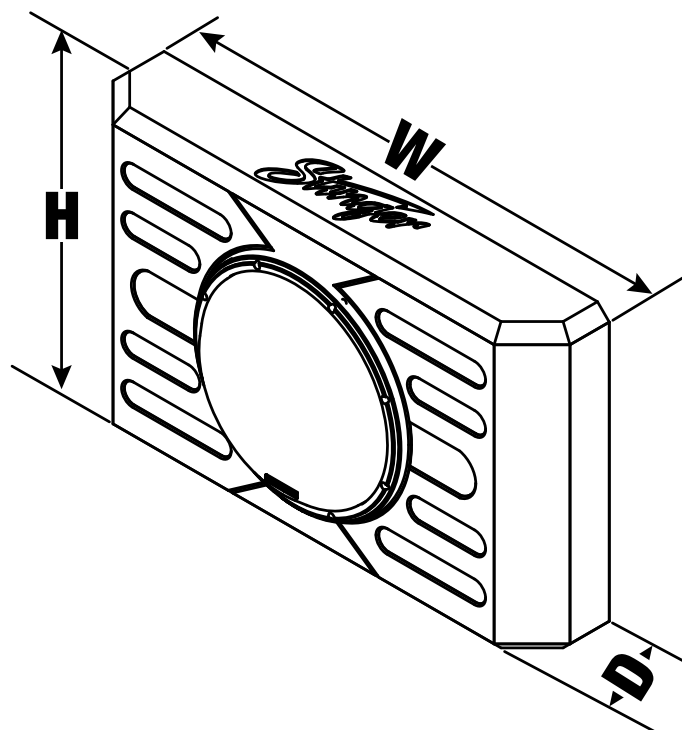



Stinger is a Power Brand of AAMP Global
15500 Lightwave, Clearwater, Florida 33760
Phone: 888-228-5560

Technical Support

Phone: 727-592-5991

Email: support@stingerelectronics.com

Chat: [stingerelectronics.com](https://www.stingerelectronics.com)

Stinger and the Stinger logo are trademarks or registered trademarks of AAMP Global in the United States and other countries.

AAMP Global is not affiliated with FCA US LLC. Jeep® is a registered trademark of FCA US LLC. The terms OEM, Jeep, Wrangler, and Gladiator all terms are used strictly for identification purposes only. It is not implied that any part listed is a product of, or approved by, Fiat Chrysler Automobiles.