

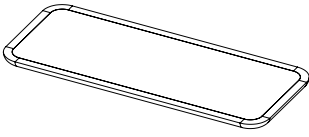
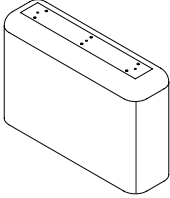
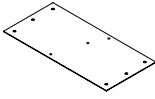

# ASSEMBLY INSTRUCTIONS

## SKU # 51011789

### PARTS LIST

<b>A</b>	<b>TOP</b> x 1		<p><b>Before Beginning</b></p> <ol style="list-style-type: none"> <li>1 - Carefully unpack and position the item on a clean, non-marring surface to assemble.</li> <li>2 - Read this Assembly Instructions from beginning to end before starting to assemble.</li> <li>3 - Take an inventory of the required parts to ensure all are available.</li> <li>4 - To prevent accidental choking hazards, keep all packing materials away from small children.</li> <li>5 - Only tighten hardware until ALL hardware are fully engaged on their locations. Overtighten bolts will damage the bolt threads.</li> <li>6 - Use only factory provided hardware to assemble. Unapproved hardware can damage product or jeopardize the structural integrity of the product.</li> <li>7 - The use of power tool to assemble is not recommended due to high risk of over-torque, which can damage the product.</li> </ol>			
<b>B</b>	<b>BASE</b> x 2					
<b>C</b>	<b>Metal Plate</b> x 2					
<b>Z</b>	<b>HARDWARE</b>	<p><b>Z1</b></p>  $\text{Ø}15 \times \text{Ø}10\text{MM}$ x 6	<p><b>Z2</b></p>  $\text{Ø}25 \times \text{Ø}10\text{MM}$ x 6	<p><b>Z3</b></p>  <b>M8 x 25MM</b> x 6	<p><b>Z4</b></p>  <b>M5 x 120MM</b> x 1	

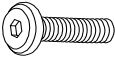
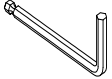
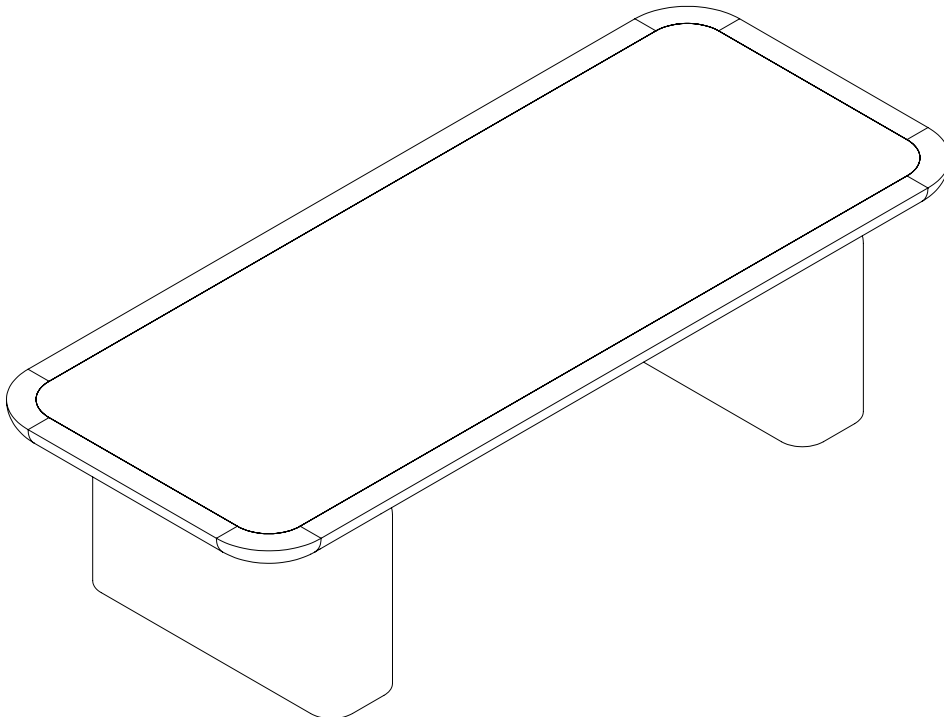

**TWO PEOPLE**



**10-MINUTE  
ASSEMBLY TIME**



**KEEP INSTRUCTIONS  
FOR FUTURE USE**

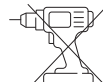

ASSEMBLY INSTRUCTIONS  
SKU # 51011789

1

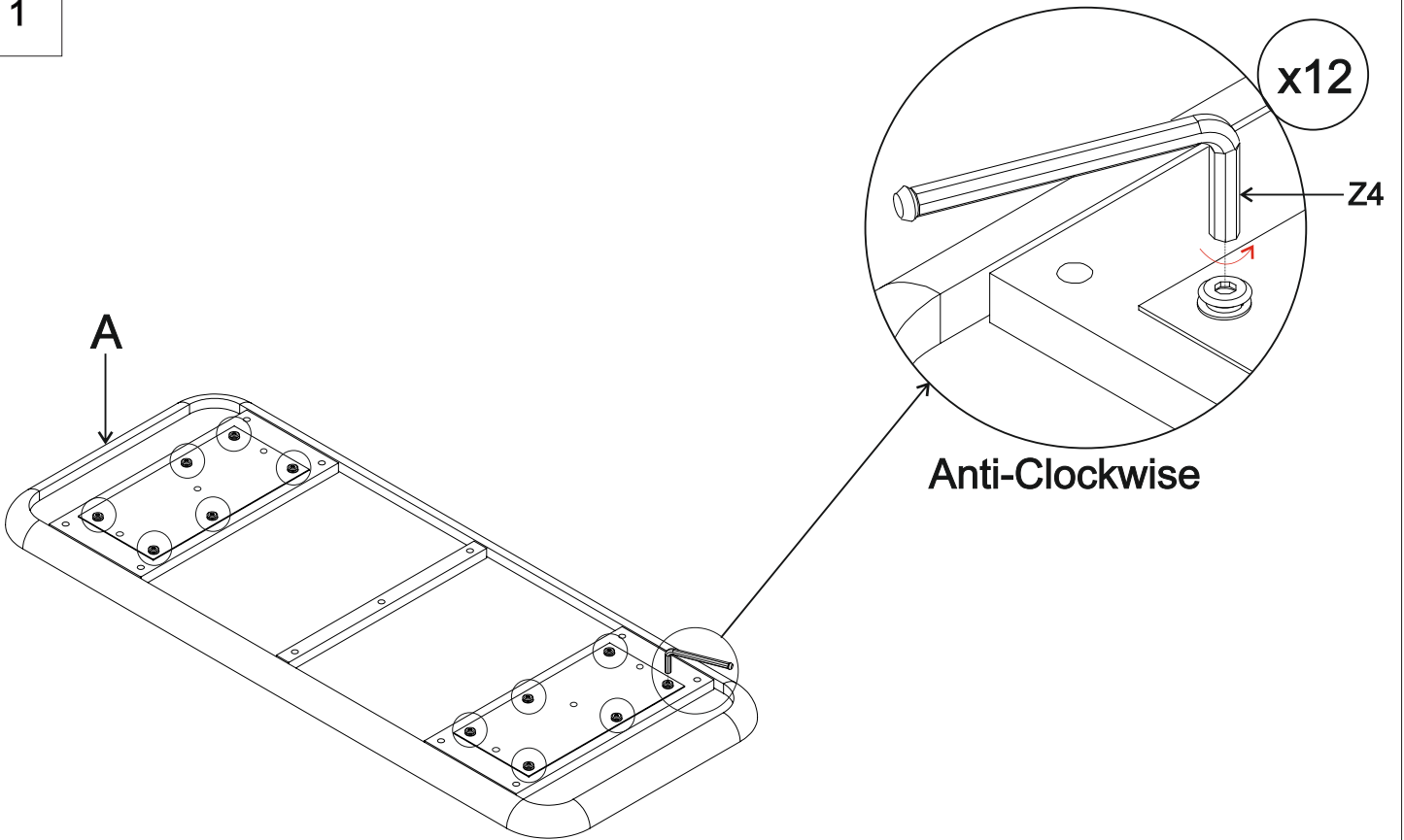

2

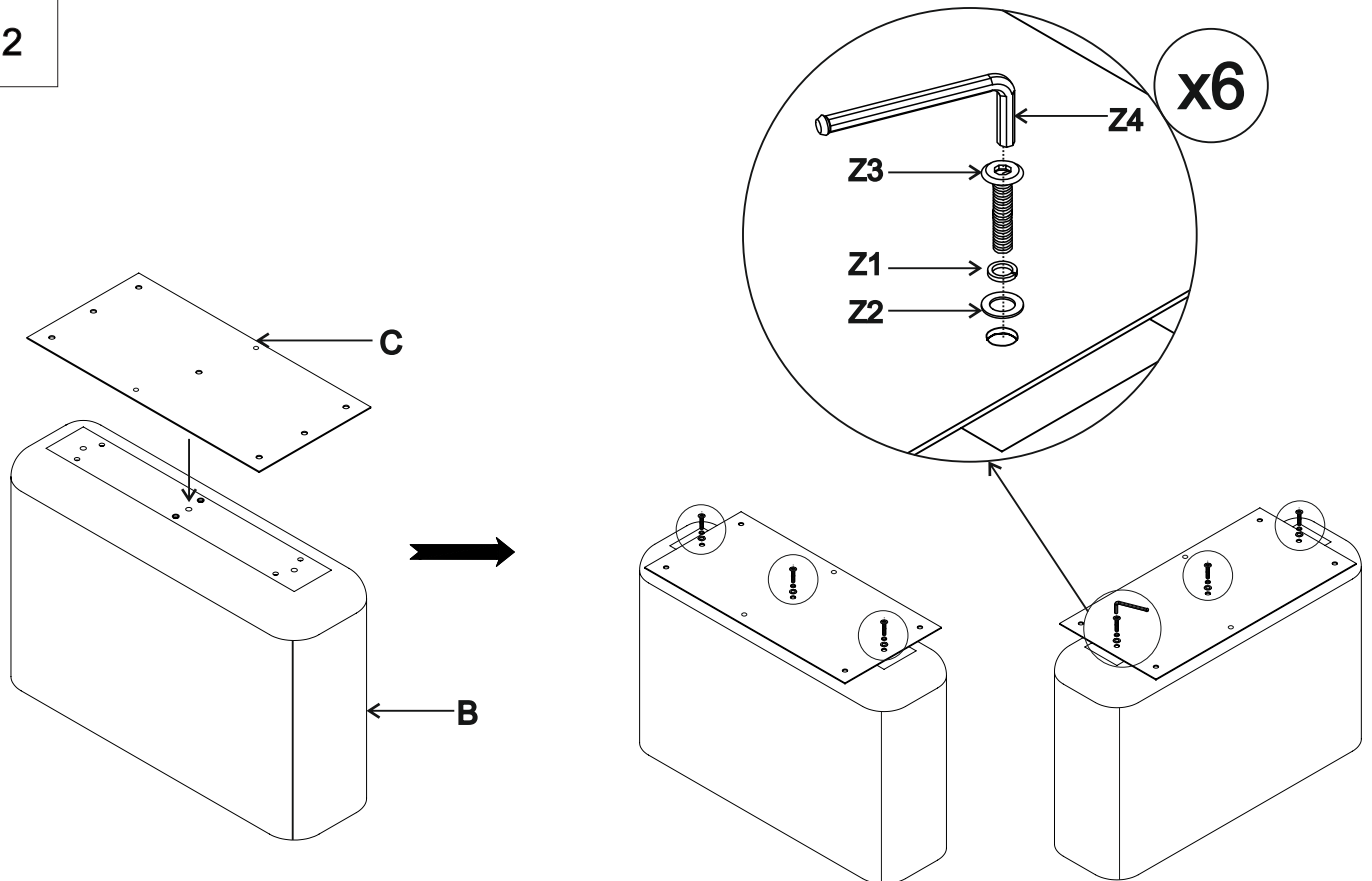

# ASSEMBLY INSTRUCTIONS

SKU # 51011789

3

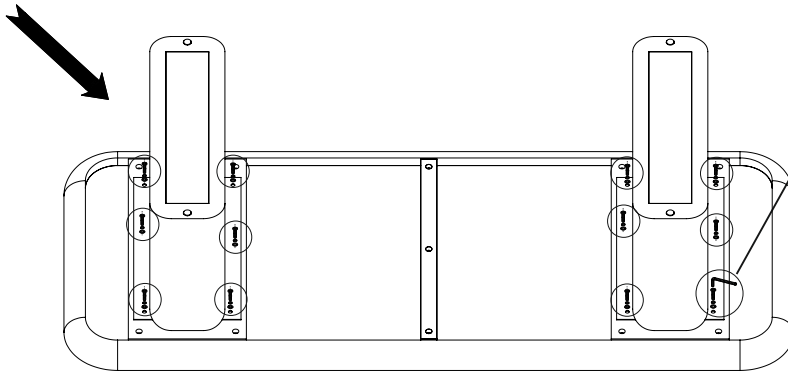
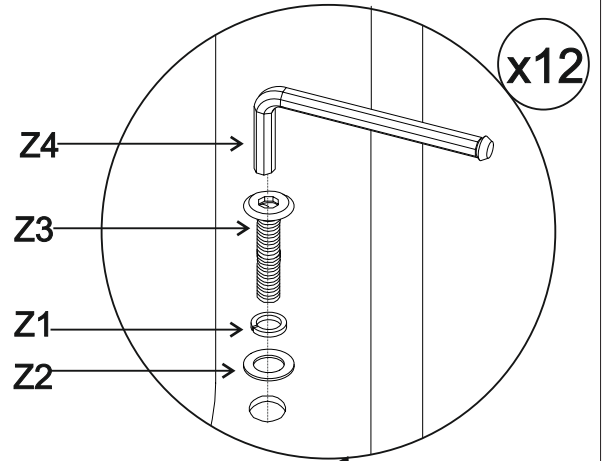
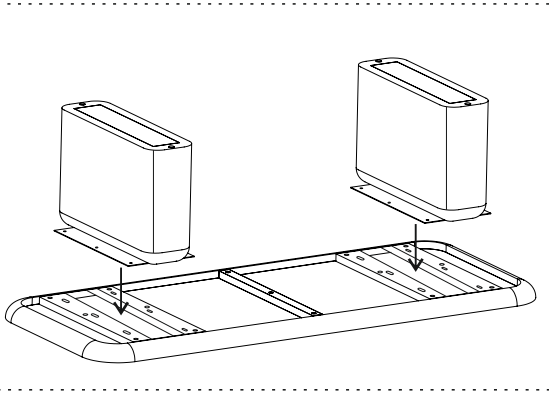

4

