



2800N+ • 2800N+ w/Premium Cart

LP OWNER'S MANUAL



REGISTER TODAY

Register your gas grill and receive special content to make you the ultimate backyard hero. Scan the QR Code or register online at weber.registria.com

⚠ DANGER

If you smell gas:

- Shut off gas to the appliance.
- Extinguish any open flames.
- Open lid.
- If odor continues, keep away from the appliance and immediately call your gas supplier or your fire department.

Failure to follow these instructions could result in fire or explosion which could cause property damage, personal injury or death.

⚠ DANGER

- Never operate this appliance unattended.
- Never operate this appliance within 24 inches (61 cm) of any structure, combustible material or other gas cylinder.
- Never operate this appliance within 25 ft (7.5 m) of any flammable liquid.
- If a fire should occur, keep away from the appliance and immediately call your fire department. Do not attempt to extinguish an oil or grease fire with water.

Failure to follow these instructions could result in fire, explosion or burn hazard, which could cause property damage, personal injury or death.

This instruction manual contains important information necessary for the proper assembly and safe use of the appliance.

Read and follow all warnings and instructions before assembling and using the appliance.

Follow all warnings and instructions when using the appliance.

Keep this manual for future reference.

Carefully follow all leak-check procedures in this Owner's Guide prior to grill operation. Do this even if the grill was dealer-assembled.

Do not ignite this appliance without first reading the burner ignition sections of this manual.

THIS GAS APPLIANCE IS DESIGNED FOR OUTDOOR USE ONLY.

Installation and Assembly

- ⚠ **DANGER:** This grill is not intended to be installed in or on recreational vehicles or boats.
- ⚠ **WARNING:** Do not use this grill unless all parts are in place and the grill was properly assembled according to the assembly instructions.
- ⚠ **WARNING:** Do not build this model of grill in any built-in or slide-in construction.
- ⚠ **WARNING:** Do not modify the appliance (grill). Liquid propane gas is not natural gas. The conversion or attempted use of natural gas in a liquid propane gas unit or liquid propane gas in a natural gas unit is unsafe and will void your warranty.
- In the United States, installation must conform with local codes or, in the absence of local codes, with either the National Fuel Gas Code, ANSI Z223.1/NFPA 54, Natural Gas and Propane Installation Code, CSA B149.1; or Propane Storage and Handling Code, B149.2; or the Standard for Recreational Vehicles, ANSI A119.2/NFPA 1192, and CSA Z240 RV Series, Recreational Vehicle Code, as applicable.
- In Canada, the installation of this grill must comply with local codes and/or the latest edition of Standard CAN/CSA-B149.2 (Propane Storage and Handling Code). These instructions, while generally acceptable, do not necessarily comply with the Canadian installation codes, particularly with piping above and below ground.
- In Mexico, if there are local codes that apply to portable gas appliances, you must comply with the latest edition of Official Mexican Standard (NOM).
- If an external electrical source is utilized (such as a rotisserie) it must be electrically grounded in accordance with local codes or, in the absence of local codes, with the National Electrical Code, ANSI/NFPA 70, or the Canadian Electrical Code, Part 1, CSA C22.1.

Operation

- ⚠ **DANGER:** Only use the grill outdoors in a well-ventilated area. Do not use in a garage, building, breezeway, tent, any other enclosed area, or beneath overhead combustible construction.
- An appliance is considered to be outdoors if installed with shelter no more inclusive than with walls on three sides, but with no overhead cover; all openings must be permanently open; sliding doors, garage doors, windows, or screened openings are not considered as permanent openings.
- An appliance is considered to be outdoors if installed with shelter no more inclusive than within a partial enclosure that includes an overhead cover and no more than two sidewalls. The sidewalls may be parallel, as in a breezeway, or at right angles to each other; all openings must be permanently open; sliding door, garage doors, windows, or screened openings are not considered as permanent openings.



FEATURES OF THIS GRILL

To access complete user information, scan the QR Code and enter your

serial number, or browse online at weber.com/literature-online.

Serial Number

Write your grill's serial number in the box above for future reference. The serial number is on the grill's data label.

8650972_092023 US



GETTING STARTED

- An appliance is considered to be outdoors if installed with shelter no more inclusive than within a partial enclosure that included an overhead cover and three sidewalls, as long as 30% or more of the horizontal periphery of the enclosure is permanently open. All openings must be permanently open; sliding doors, garage doors, windows, or screened openings are not considered as permanent openings.
- The minimum ambient operating temperature for safe use of the appliance shall be 0° F (-17° C).

- ⚠ **DANGER:** Do not use the grill in any vehicle or in any storage or cargo area of any vehicle. This includes, but is not limited to, cars, trucks, station wagons, mini-vans, sport utility vehicles, recreational vehicles, and boats.
- ⚠ **DANGER:** Do not use the grill within 24 inches (61 cm) of combustible materials. This includes the top, bottom, back and sides of the grill.
- ⚠ **DANGER:** Keep the cooking area clear of flammable vapors and liquids such as gasoline, alcohol, etc., and combustible materials.
- ⚠ **DANGER:** This appliance (grill) must be kept away from flammable materials during use.
- ⚠ **DANGER:** Do not put a grill cover or anything flammable on, or in the storage area under the grill while it is in operation or is hot.
- ⚠ **DANGER:** Should a grease fire occur, turn off all burners and leave lid closed until fire is out.
- ⚠ **WARNING:** Accessible parts may be very hot. Keep young children away.
- ⚠ **WARNING:** The use of alcohol, prescription drugs, non-prescription drugs, or illegal drugs may impair the consumer's ability to properly and safely assemble, move, store, or operate the grill.
- ⚠ **WARNING:** Never leave the grill unattended during pre-heating or use. Exercise caution when using this grill. The entire cookbox gets hot when in use.
- ⚠ **WARNING:** Do not move the appliance (grill) during use.
- ⚠ **WARNING:** Keep any electrical supply cord and the fuel supply hose away from any heated surfaces.
- ⚠ **CAUTION:** This product has been safety-tested and is only certified for use in a specific country. Refer to country designation located on outside of box.
- Do not use charcoal or lava rock in the grill.

Storage and/or Non-Use

- ⚠ **WARNING:** Turn off the gas supply at the gas cylinder (tank) after use.
- ⚠ **WARNING:** LP tanks must be stored outdoors out of the reach of children and must not be stored in a building, garage, or any other enclosed space.
- ⚠ **WARNING:** After a period of storage and/or nonuse, the grill should be checked for gas leaks and burner obstructions before use.
- ⚠ Storage of the grill indoors is permissible only if the LP tank is disconnected and removed from the grill.

California Proposition 65

- ⚠ **WARNING:** Combustion byproducts produced when using this product contain chemicals known to the state of California to cause cancer, birth defects, or other reproductive harm.
- ⚠ **PROPOSITION 65 WARNING:** Handling the brass material on this product exposes you to lead, a chemical known to the state of California to cause cancer, birth defects, or other reproductive harm. *Wash hands after handling this product.*

Limited Warranty

Thank you for purchasing a WEBER product. Weber-Stephen Products LLC, 1415 S. Roselle Road, Palatine, Illinois 60067 ("WEBER") prides itself on delivering a safe, durable, and reliable product.

This is WEBER's Limited Warranty provided to you at no extra charge. It contains the information you will need to have your WEBER product repaired in the unlikely event of a failure or defect.

Pursuant to applicable laws, the customer has several rights in case the product is defective. Those rights include supplementary performance or replacement, abatement of the purchasing price, and compensation. These and other statutory rights remain unaffected by this warranty provision. In fact, this warranty grants additional rights to the Owner that are independent from statutory warranty provisions.

WEBER'S LIMITED WARRANTY

WEBER warrants, to the purchaser of the WEBER product (or in the case of a gift or promotional situation, the person for whom it was purchased as a gift or promotional item) ("Owner"), that the WEBER product is free from defects in material and workmanship for the period(s) of time specified below when assembled and operated in accordance with the accompanying Owner's Manual, normal wear and tear excluded. (Note: If you lose or misplace your WEBER Owner's Manual, a replacement is available online at www.weber.com.) WEBER agrees within the framework of this warranty to repair or replace the part that is defective in material or workmanship subject to the limitations, and exclusions listed below. TO THE EXTENT ALLOWABLE BY APPLICABLE LAW, THIS WARRANTY IS EXTENDED ONLY TO THE ORIGINAL PURCHASER AND IS NOT TRANSFERABLE TO SUBSEQUENT OWNERS, EXCEPT IN THE CASE OF GIFTS AND PROMOTIONAL ITEMS AS NOTED ABOVE.

WEBER stands by its products and is happy to provide you with the Warranty described for material defects in the grill or its relevant components, normal wear and tear excepted.

- "Normal wear and tear" includes cosmetic and other immaterial deterioration that may come with ownership of your grill over time, such as surface rust, dents / scratches, etc.

However, WEBER will honor this Warranty for the grill or its relevant components where damage or dysfunction results from a material defect.

- "Material defect" includes rust through or burn through of certain parts, or other damage or failure inhibiting your ability to safely / properly use your grill.

OWNER'S RESPONSIBILITIES UNDER THIS WARRANTY

To ensure trouble-free warranty coverage, it is important (but it is not required) that you register your WEBER product online at www.weber.com. Please also retain your original sales receipt and/or invoice. Registering your WEBER product confirms your warranty coverage and provides a direct link between you and WEBER in case we need to contact you. If you have not had time to register your grill before calling for Warranty service, please have the following information available when you do call:

Name – Address – Phone Number – Email – Serial Number – Purchase Date – Purchase Dealer – Model – Color – Primary Issue

The above warranty only applies if the Owner takes reasonable care of the WEBER product by following all assembly instructions, usage instructions, and preventative maintenance as outlined in the accompanying Owner's Manual, unless the Owner can prove that the defect or failure is independent of non-compliance with the above mentioned obligations. If you live in a coastal area, or have your product located near a pool, maintenance includes regular washing and rinsing of the exterior surfaces as outlined in the accompanying Owner's Manual.

WARRANTY HANDLING / EXCLUSION OF WARRANTY

If you believe that you have a part which is covered by this Warranty, please contact WEBER Customer Service using the contact information on our website (www.weber.com), or such country-specific website to which Owner may be redirected).

WEBER will, upon investigation, repair or replace (at its option) a defective part that is covered by this Warranty. In the event that repair or replacement are not possible, WEBER may choose (at its option) to replace the grill in question with a new grill of equal or greater value. WEBER may ask you to return parts for inspection, shipping charges to be pre-paid by owner.

When you contact Customer Service, please have the following information available:

Name – Address – Phone Number – Email – Serial Number – Purchase Date – Purchase Dealer – Model – Color – Primary Issue

This WARRANTY lapses if there are damages, deteriorations, discolorations, and/or rust for which WEBER is not responsible caused by:

- Abuse, misuse, alteration, modification, misapplication, vandalism, neglect, improper assembly or installation, and failure to properly perform normal and routine maintenance;
- Insects (such as spiders) and rodents (such as squirrels), including but not limited to damage to burner tubes and/or gas hoses;
- Exposure to salt air and/or chlorine sources such as swimming pools and hot tubs/spas;
- Severe weather conditions such as hail, hurricanes, earthquakes, tsunamis or surges, tornadoes or severe storms.
- Acid rain and other environmental factors.

Using third party parts will not void this Warranty. However, any parts that are used and/or installed on your WEBER product that are not genuine WEBER parts are not covered by this Warranty. In addition, any damages that result from the use and/or installation of parts on your WEBER product that are not genuine WEBER parts are not covered by this Warranty. Any conversion of a gas grill not authorized by WEBER and performed by a WEBER authorized service technician will void this Warranty.

PRODUCT WARRANTY PERIODS

Cookbox:
5 years, no rust through/burn through
(2 years paint, excluding fading or discoloration)

Lid assembly:
5 years, no rust through/burn through
(2 years paint, excluding fading or discoloration)

Stainless steel burner tubes:
5 years, no rust through/burn through

Porcelain-enameled cast iron cooking grates:
5 years, no rust through/burn through

Plastic components:
5 years, excluding fading or discoloration

All remaining parts:
2 years

DISCLAIMERS

APART FROM THE WARRANTY AND DISCLAIMERS AS DESCRIBED IN THIS WARRANTY STATEMENT, THERE ARE EXPLICITLY NO FURTHER WARRANTY OR VOLUNTARY DECLARATIONS OF LIABILITY GIVEN HERE WHICH GO BEYOND THE STATUTORY LIABILITY APPLYING TO WEBER. THE PRESENT WARRANTY STATEMENT ALSO DOES NOT LIMIT OR EXCLUDE SITUATIONS OR CLAIMS WHERE WEBER HAS MANDATORY LIABILITY AS PRESCRIBED BY STATUTE. NO WARRANTIES SHALL APPLY AFTER THE APPLICABLE PERIODS OF THIS WARRANTY. NO OTHER WARRANTIES GIVEN BY ANY PERSON, INCLUDING A DEALER OR RETAILER, WITH RESPECT TO ANY PRODUCT (SUCH AS ANY "EXTENDED WARRANTIES"), SHALL BIND WEBER. THE EXCLUSIVE REMEDY OF THIS WARRANTY IS REPAIR OR REPLACEMENT OF THE PART OR PRODUCT.

IN NO EVENT UNDER THIS WARRANTY SHALL RECOVERY OF ANY KIND BE GREATER THAN THE AMOUNT OF THE PURCHASE PRICE OF THE WEBER PRODUCT SOLD. YOU ASSUME THE RISK AND LIABILITY FOR LOSS, DAMAGE, OR INJURY TO YOU AND YOUR PROPERTY AND/OR TO OTHERS AND THEIR PROPERTY ARISING OUT OF THE MISUSE OR ABUSE OF THE PRODUCT OR FAILURE TO FOLLOW INSTRUCTIONS PROVIDED BY WEBER IN THE ACCOMPANYING OWNER'S MANUAL.

PARTS AND ACCESSORIES REPLACED UNDER THIS WARRANTY ARE WARRANTED ONLY FOR THE BALANCE OF THE ABOVE MENTIONED ORIGINAL WARRANTY PERIOD(S).

THIS WARRANTY APPLIES TO PRIVATE SINGLE FAMILY HOME OR APARTMENT USE ONLY AND DOES NOT APPLY TO WEBER GRILLS USED IN COMMERCIAL, COMMUNAL OR MULTI-UNIT SETTINGS SUCH AS RESTAURANTS, HOTELS, RESORTS, OR RENTAL PROPERTIES.

WEBER MAY FROM TIME TO TIME CHANGE THE DESIGN OF ITS PRODUCTS. NOTHING CONTAINED IN THIS WARRANTY SHALL BE CONSTRUED AS OBLIGATING WEBER TO INCORPORATE SUCH DESIGN CHANGES INTO PREVIOUSLY MANUFACTURED PRODUCTS, NOR SHALL SUCH CHANGES BE CONSTRUED AS AN ADMISSION THAT PREVIOUS DESIGNS WERE DEFECTIVE.

Webster-Stephen Products LLC
Customer Service Center
1415 S. Roselle Road
Palatine, IL 60067
U.S.A.

For replacement parts, call:
1-800-446-1071





Important Information about LP Gas & Gas Connections

What Is LP Gas?

Liquefied petroleum gas, also called LP, LP gas, liquid propane, or simply propane or butane, is the flammable, petroleum-based product used to fuel your grill. It is a gas at moderate temperatures and pressure when it is not contained. But at moderate pressure inside a container, such as a tank, LP is a liquid. As pressure is released from the tank, the liquid readily vaporizes and becomes gas.

Safe Handling Tips For LP Tanks

- A dented or rusty liquid propane tank may be hazardous and should be checked by your liquid propane supplier. Do not use a liquid propane tank with a damaged valve.
- Although your liquid propane tank may appear to be empty, gas may still be present, and the tank should be transported and stored accordingly.
- The LP tank must be installed, transported, and stored in an upright, secure position. LP tanks should not be dropped or handled roughly.
- Never store or transport the LP tank where temperatures can reach 125° F (51.7° C) (the tank will become too hot to hold by hand).
- Place dust cap on cylinder valve outlet whenever the cylinder is not in use. Only install the type of dust cap on the cylinder valve outlet that is provided with the cylinder valve. Other types of caps or plugs may result in leakage of propane.

LP Tank Requirements

- The tank must be approximately 18 1/4 inches (46.35 cm) high and 12 1/4 inches (31.1 cm) in diameter with a marked 20 pound (9.07 kg) LP capacity or 47.6 pound (21.6 kg) water capacity as stated by the manufacturer. Other tanks may be acceptable provided they are compatible with the grill retention means (tank scale).
- The tank used must be constructed and marked in accordance with the Specifications for LP gas Cylinders of the U.S. Department of Transportation (D.O.T.); or the Canadian Standard for Cylinders, Spheres and Tubes for Transportation of Dangerous Goods and Commission, CAN/CSA-B339, as applicable.
- Tanks must be provided with a listed OPD (Overfilling Prevention Device) and a Type 1 (CGA 791) tank connection.
- The tank must include a collar to protect the tank valve.
- Tanks must have a D.O.T. certification (A), and a testing date (B) that is within five years of current use.

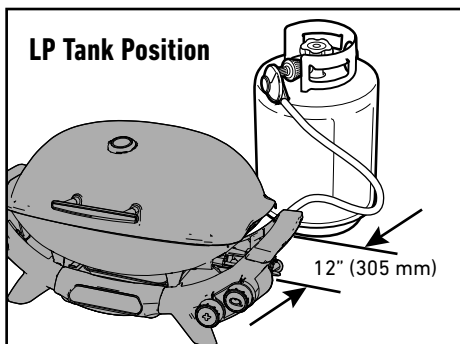
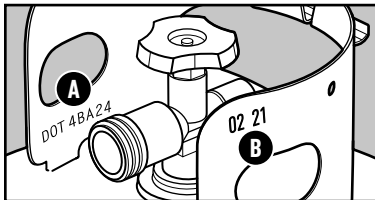

⚠ WARNING: Avoid tipping hazard. Position the LP tank behind grill on the right-hand side.

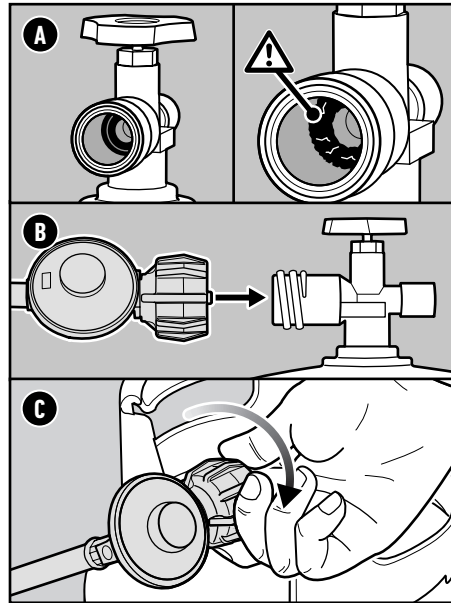

LP Tank Installation

While using the gas hose, use care to route the gas hose away from the cookbox and other hot surfaces.

Only use the hose assembly as supplied with this appliance for connection to the cylinder - DO NOT USE ADAPTORS.

Inspect the Tank

- 1) Confirm that the tank valve is fully closed. Close by turning valve clockwise.
- 2) Inspect the tank valve, including the internal rubber seal for damage or debris (A). If damaged, return tank to local retailer.
- 3) Confirm that the tank valve is the proper mating type for the regulator (B).

Tank Installation

- 1) Place the LP tank on the ground behind the grill.
- 2) Turn the LP tank so the opening of the valve faces the side or back of the grill.

Connect the Gas Hose to the Tank

- 1) Check that the burner control knob(s) is(are) in the off O position. Check by pushing in and turning knob(s) clockwise.
- 2) Connect the gas hose coupling to the LP tank. Hand tighten only.
 - a) Tighten by turning the fitting clockwise (C).

What is a Regulator?

Your gas grill is equipped with a pressure regulator, which is a device to control and maintain uniform gas pressure as gas is released from the LP tank.

Regulator Requirements

- Each WEBER pressure regulator is designed for vapor withdrawal. Cylinder must be upright when grill is in use.
- The regulator and hose assembly supplied with this grill must be used. This regulator has a flow limiting device built into the unit that will restrict the flow of gas in the event that a leak is detected.
- Replacement regulator and hose assemblies must be as specified by Weber-Stephen Products LLC (UL-listed Type 1 (CGA 791) tank connection device as described in the latest edition of ANSI Z21.81).

⚠ WARNING: It may be hazardous to attempt to fit other types of gas containers.

⚠ IMPORTANT: We recommend that you replace the gas hose assembly on your gas grill every five years. Some countries may have requirements that the gas hose be replaced within less than five years, in which case that country's requirement would take precedence.

For replacement hose, regulator, and valve assemblies, contact the Customer Service Representative in your area using the contact information on our web site. Log on to weber.com.

⚠ This appliance is not suitable for installation or connection to a reticulated gas supply.

LP Tank Installation Using the Premium Cart

This feature is only available on select models.

⚠ While using the premium cart, the tank must be secured inside the cart.

LP Tank Requirements

- Use a tank with a maximum capacity of 20 pounds (9.07 kg).

LP Tank Installation

- 1) Open the door of the premium cart.
- 2) Lift LP tank into position inside the cart (D).
- 3) Turn the LP tank so the opening of the valve faces the inside of the cart.
- 4) Secure the LP tank by tightening the hand wheel on the base of the cart (E).

Connect the Gas Hose to the LP Tank

- 1) Check that the burner control knobs are in the off O position. Check by pushing in and turning knobs clockwise.
- 2) Route the gas line behind the cart as illustrated (F). Connect the gas hose coupling to the LP tank. Hand tighten only.
 - a) Tighten by turning the fitting clockwise (C).

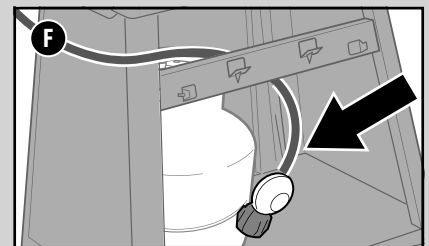
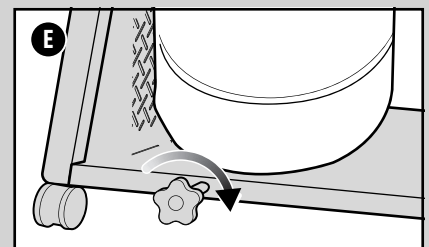
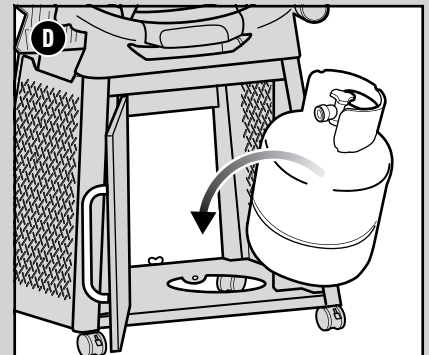



GETTING STARTED

Conducting a Leak Check

Once the LP tank is properly installed, it is necessary to perform a leak check. A leak check is a reliable way to verify that gas is not escaping after you connect the LP tank. Weber recommends performing a thorough leak check after assembly, as well as annually. The following fittings should be tested:

- Where the LP tank connects to the regulator.
- Where the regulator connects to the gas hose.
- Where the gas hose connects to the burner valve.

Checking for Gas Leaks

If there is a leak from your appliance (smell of gas) immediately attempt to turn off the tank valve. Remove the appliance to a well-ventilated location away from any ignition source. Check for leaks using soapy water. Do not try to detect leaks using a flame.

1) Wet fittings (A) with a soap and water solution, using a spray bottle, brush, or rag. You can make your own soap and water solution by mixing 20% liquid soap with 80% water; or, you can purchase leak check solution in the plumbing section of any hardware store.

2) Slowly open gas supply by turning tank valve counter-clockwise while checking for bubbles.

3) If bubbles appear there is a leak:

- If the leak is at the LP tank (B), turn off the gas. Disconnect the regulator, then reconnect and test. If the leak persists DO NOT OPERATE THE GRILL. Disconnect the LP tank. Contact the Customer Service Representative in your area using the contact information on our website.
- If the leak is at regulator (C), or at the fitting indicated in illustration (D), DO NOT OPERATE THE GRILL. Contact the Customer Service Representative in your area using the contact information on our website.

If a leak is present, contact the Customer Service Representative in your area using the contact information on our website.

4) If bubbles do not appear, leak checking is complete:

- Turn gas supply off at the LP tank and rinse connections with water.

NOTE: Since some leak test solutions, including soap and water, may be slightly corrosive, all connections should be rinsed with water after checking for leaks.

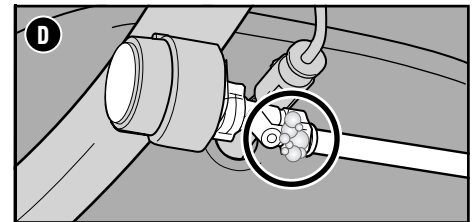
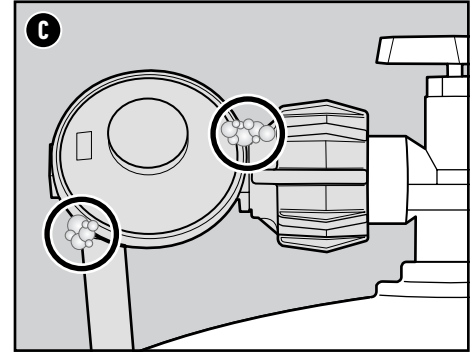
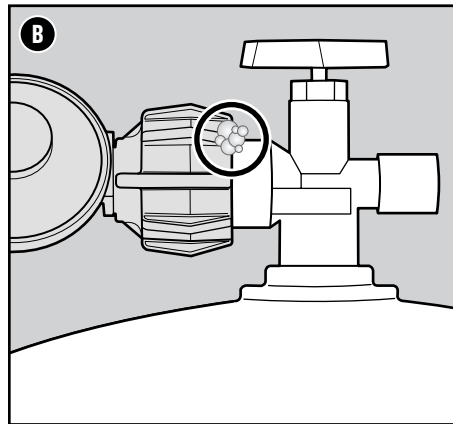
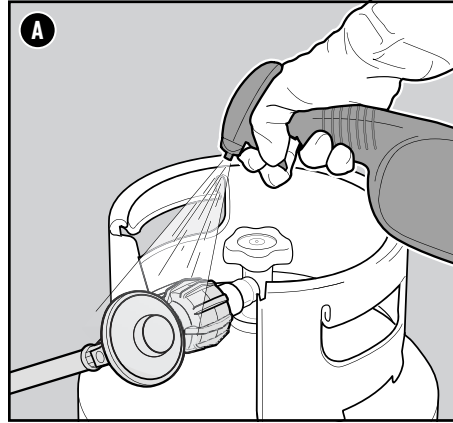

Refilling or Replacing an LP Tank

Removing the LP Tank

Every time your LP tank needs to be refilled or replaced, follow these instructions to remove it.

- 1) Confirm that the tank valve is fully closed. Close by turning valve clockwise.
- 2) Unscrew gas hose coupling from the tank.

Additional Leak Check Precautions

The following fittings should be tested for gas leaks each time an LP tank is refilled and reinstalled:

- Where the regulator connects to the LP tank (B) and at the regulator (C).

Follow the instructions for "Checking for Gas Leaks".

⚠ **DANGER:** Do not use a flame to check for gas leaks. Be sure there are no sparks or open flames in the area while you check for leaks.

⚠ **DANGER:** Leaking gas may cause a fire or explosion.

⚠ **DANGER:** Do not operate the grill if there is a gas leak present.

⚠ **DANGER:** If you see, smell, or hear the hiss of gas escaping from the liquid propane tank:

- 1) Move away from liquid propane tank.
- 2) Do not attempt to correct the problem yourself.

3) Call your fire department.

⚠ **DANGER:** Always close the tank valve before disconnecting the regulator. Do not attempt to disconnect the gas regulator and hose assembly or any gas fitting while this grill is in operation.

⚠ **DANGER:** Do not store a spare LP tank under or near this grill. Never fill the tank beyond 80% full. Failure to follow these statements exactly may result in a fire causing death or serious injury.

Burner Control Knob Settings

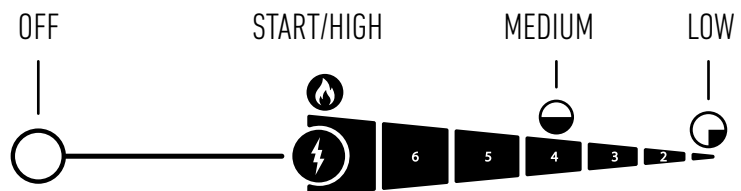



Igniting the Grill

Using the Ignition System to Ignite the Main Burner

The ignition system ignites the burner with a spark from the igniter electrode. You generate the energy for the spark by pushing the igniter button. You will hear the igniter ticking.

- 1) Open the grill lid (A).
- 2) Check that the burner control knobs are in the off \circ position. Check by pushing in and turning each knob clockwise (B).
Note: It is important that all burner control knobs are in the off \circ position before turning on the LP tank. If they are not, the flow limiting device built into the regulator will activate, limiting the flow of gas from the LP tank.
- 3) Turn the LP tank on by slowly turning the tank valve counterclockwise; wait 60 seconds.
Note: It is important that the LP tank is turned on slowly. If it is opened too quickly, the flow limiting device built into the regulator will activate, limiting the flow of gas from the LP tank.
- 4) Push the main burner control knob in and turn it counterclockwise to the start/high ⚡ position (C).
- 5A) Push the red igniter button several times, so it clicks each time (D).
- 5B) Push and hold the electronic igniter button (E). You will hear it ticking.
- 6) Check that the burner is lit by looking through the cooking grates. You should see a flame.
- 7) If the burner does not ignite within 5 seconds, turn burner control knob to the off \circ position and wait five minutes to allow the gas to clear before attempting to light the burner again.

Should the burner fail to ignite using the ignition system, refer to the TROUBLESHOOTING section. There you will find instructions on igniting the grill with a match to help determine the exact problem.

Preheating the Grill

Preheating the grill is critical to successful barbecuing. Preheating helps to prevent food from sticking to the grates and gets the grates hot enough to sear properly. It also burns off residue of a previously cooked meal.

- 1) Open the grill lid.
- 2) Ignite your grill according to the ignition instructions in this Owner's Manual.
- 3) Close lid.
- 4) Preheat the grill with the burners on the start/high ⚡ position for 10 to 15 minutes or until thermometer registers 500° F (260° C) (C).
- 5) After preheating on high is complete, you may adjust the burner control knob to your desired setting for barbecuing.

To Extinguish Burner

- 1) Push the burner control knob in and then turn clockwise all the way to the off \circ position.
- 2) Turn gas supply off.

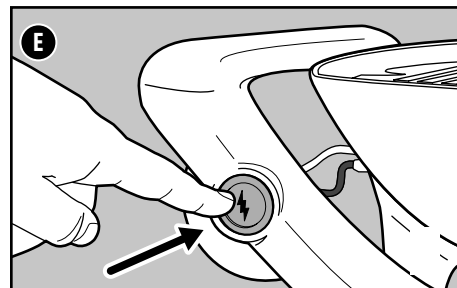
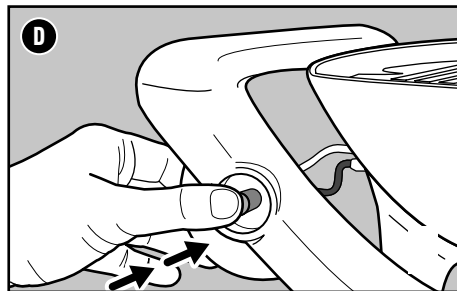
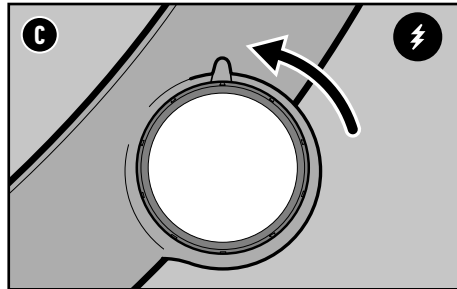
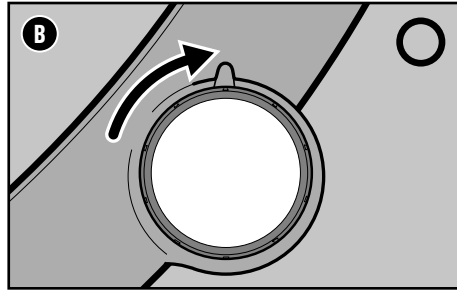
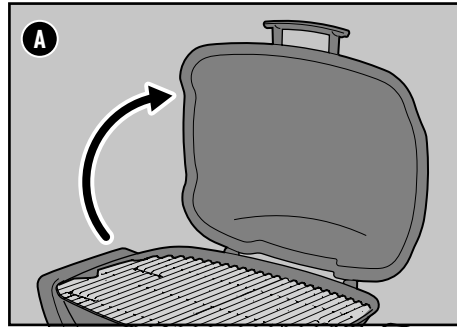

- ⚠ WARNING: Open lid during ignition.
- ⚠ WARNING: Do not lean over open grill while igniting or cooking.
- ⚠ WARNING: If ignition does not occur within five seconds, turn the burner control knob to the off position. Wait five minutes to allow accumulated gas to dissipate, and then repeat the lighting procedure.

Using the + Burner

This feature is only available on select models.

The + burner provides the versatility of searing food at a high temperature when combined with the main burner, or low and slow cooking when using the + burner alone.

SEARING

- 1) Open the lid and ignite both burners including the + burner (A). Begin with igniting the main burner first.

IMPORTANT: Always ignite the main burner first. The + burner ignites from the main burner.

Refer to IGNITING THE GRILL.

- 2) Preheat the grill with the lid closed and with all burners on the high ⚡ position for 10 to 15 minutes or until thermometer registers 500° F (260° C).
- 3) After preheating, leave the + burner control knob and the main burner control knob in the high ⚡ position. The + burner works in tandem with the main burner (B).

- 4) Place food directly over the + burner and close lid.

LOW AND SLOW

- 1) Open the lid and ignite both burners including the + burner. Begin with igniting the main burner first.

IMPORTANT: Always ignite the main burner first. The + burner ignites from the main burner.

Refer to IGNITING THE GRILL.

- 2) Preheat the grill with the lid closed and with all burners on the high ⚡ position for 10 to 15 minutes or until thermometer registers 500° F (260° C).
- 3) After preheating, leave only the + burner control knob in the high ⚡ position and turn the main burner control knob off.

Note: Always cook with the lid closed to achieve maximum heat and to avoid flare-ups.

To Extinguish Burner(s)

- 1) Push burner control knob(s) in and then turn clockwise all the way to the off \circ position.
- 2) Turn gas supply off.

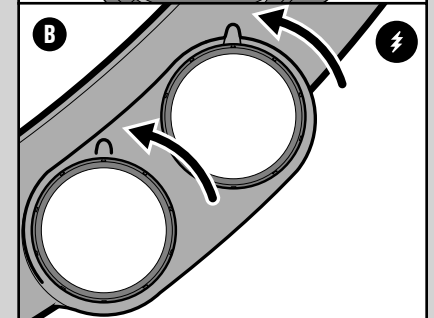
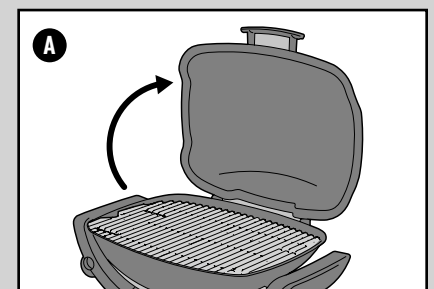



PRODUCT CARE

Cleaning and Maintenance

Cleaning the Inside of the Grill

Over time, the performance of your grill can diminish if it has not been maintained properly. Low temperatures, uneven heat, and food sticking to cooking grates are all signs that cleaning and maintenance are overdue.

A thorough cleaning is recommended when the grill is going to be stored, or at least twice a year. Consistent use may require quarterly cleanings. When your grill is off and cool, start by cleaning the inside, from the top down.

Cleaning the Lid

From time to time you may notice "paint-like" flakes on the inside of the lid. During use, grease and smoke vapors slowly change into carbon and deposit on the inside of your lid. These deposits will eventually peel, and look very similar to paint. These deposits are non-toxic, but the flakes could fall onto your food if you do not clean the lid regularly.

- 1) Brush the carbonized grease from the inside of the lid with a stainless steel bristle grill brush (A). To minimize further build-up, the inside of the lid can be wiped with a paper towel after barbecuing while the grill is still warm (not hot).

Cleaning the Cooking Grates

If you have been cleaning your cooking grates before every cook, as recommended, the debris on your grates should be minimal.

- 1) With grates installed, brush the debris off your cooking grates with a stainless steel bristle grill brush (B).

Cleaning the Burner

Two areas on the burner that are key to optimum performance are the ports (small openings running along the length of the burner) and the spider/insect screens on the ends of the burner. Keeping these areas clean is essential for safe operation.

Cleaning the Burner Ports

- 1) Take the cooking grates out and set aside.
- 2) Use a clean stainless steel bristle grill brush to clean the outside of the burners by brushing across the top of the burner ports (C). Do not brush lengthwise along the tube, as this will only brush debris from one port to another.
- 3) When cleaning the burner, avoid damaging the ignition electrode by carefully brushing around it.

Cleaning the Spider Screens

- 1) Locate the end of the burner behind the control panel where it meets the valve.
- 2) Remove the screw from the top of the rain shield, then remove the rain shield from the burner tube (on select models only) (D).
- 3) Clean the spider/insect screen on the burner using a soft bristle brush (E).
- 4) Reinstall the rain shield over the end of the burner tube and secure with screw.

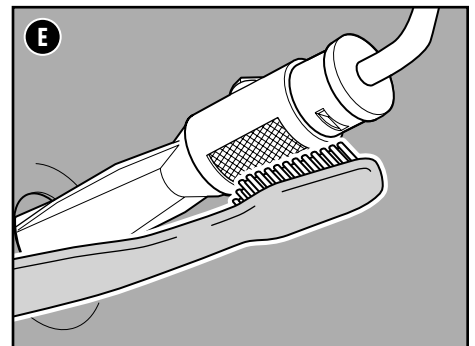
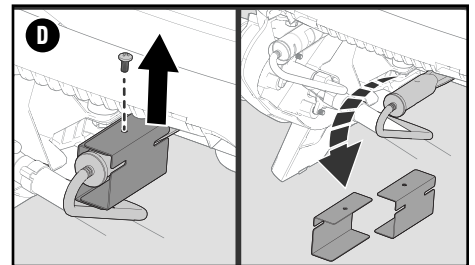
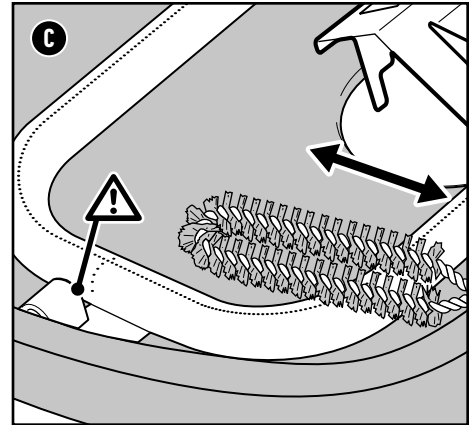
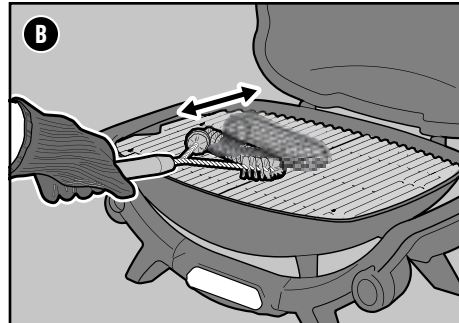
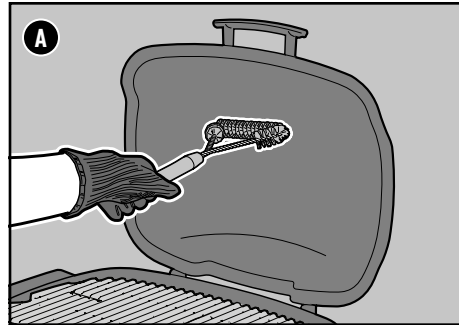

⚠ **DANGER:** Do not line the slide-out grease tray or cookbox with aluminum foil.

⚠ **DANGER:** Check the slide-out grease tray and catch pan for grease build-up before each use. Remove excess grease to avoid a grease fire.

⚠ **WARNING:** Use caution when removing catch pan and disposing of hot grease.

⚠ **WARNING:** Use heat-resistant barbecue mitts or gloves when operating grill.

⚠ **WARNING:** Grill brushes should be checked for loose bristles and excessive wear on a regular basis. Replace brush if any loose bristles are found on cooking grates or brush. WEBER recommends purchasing a new stainless steel bristle grill brush at the beginning of every spring.

⚠ **WARNING:** Keep ventilation openings around tank clear and free of debris.

⚠ **WARNING:** Keep the fuel supply hose away from heated surfaces.



Cleaning the Cookbox

Look inside the cookbox for any grease accumulation or leftover food particles. Excessive accumulation can cause a fire.

- 1) Take the cooking grates out and set aside.
- 2) Use a plastic scraper to scrape debris off the sides and bottom of the grill into the opening in bottom of the cookbox (F). This opening leads debris into the slide-out catch pan.
- 3) Some models come with a heat deflector which sits in the bottom of the bowl. This can be cleaned using a plastic scraper or can be easily removed and washed with hot soapy water. After cleaning the heat deflector, make sure it is properly seated over the opening in the bottom of the cookbox.

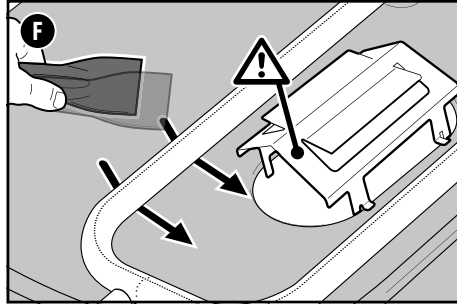

Cleaning the Grease Management System

The grease management system consists of a slide-out catch pan and a disposable drip tray (G). These components were designed to be easily removed, cleaned, and replaced; an essential step every time you prepare to grill.

Cleaning the Outside of the Grill

The outside of your grill may include stainless steel, painted aluminium, and plastic surfaces. WEBER recommends the following methods based on the surface type.

Cleaning Painted Aluminium Surfaces and Plastic Components

Clean painted aluminium and plastic components with warm soapy water, and paper towels or cloth. After wiping down the surfaces, rinse and dry thoroughly.

Cleaning the Outside of Grills that are in Unique Environments

If your grill is subject to a particularly harsh environment, you will want to clean the outside more often. Acid rain, pool chemicals, and salt water can cause surface rusting to appear. Wipe down the outside of your grill with warm soapy water. Follow up with a rinse and thorough drying.

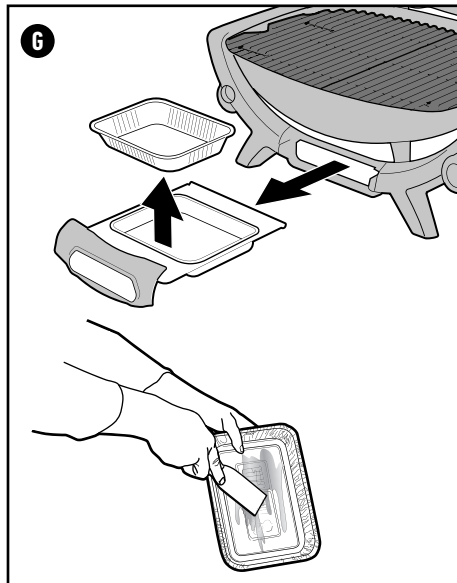

⚠ **WARNING:** Turn your grill off and wait for it to cool before thoroughly cleaning.

⚠ **WARNING:** When cleaning the burners, never use a brush that has already been used to clean the cooking grates. Never put sharp objects into the burner port holes.

⚠ **CAUTION:** Do not use any of the following to clean your grill: abrasive stainless steel polishes or paints, cleaners that contain acid, mineral spirits or xylene, oven cleaner, abrasive cleansers (kitchen cleansers), or abrasive cleaning pads.

Proper Burner Flame Pattern

The burner in your grill is factory set for the correct air and gas mixture. When the burner is performing correctly, you will see a specific flame pattern. The tips may occasionally flicker yellow (A), with a descending light blue (B) to dark blue flame (C).

⚠ **WARNING:** Blocked and dirty ports can restrict full gas flow, resulting in a fire (D) in and around the gas valves, causing serious damage to your grill.

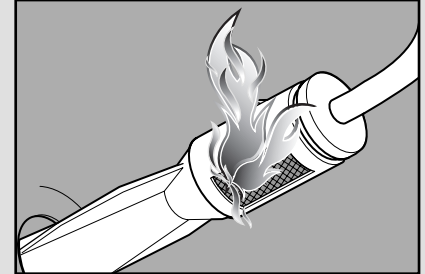
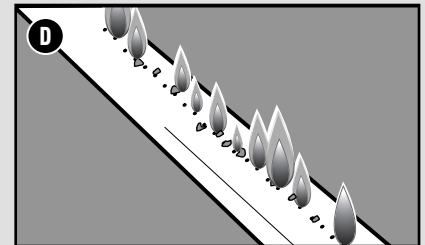
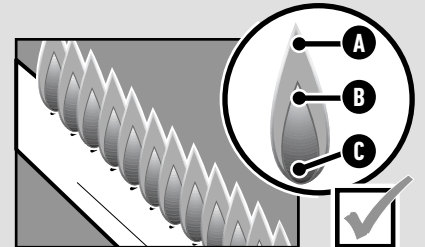

Spider Screens

The combustion air openings of the burners (E) are fitted with stainless steel screens to prevent spiders and other insects from spinning webs and building nests inside the burners. Additionally, dust and debris can accumulate on the outside of the spider/insect screen and obstruct the oxygen flow to the burners.

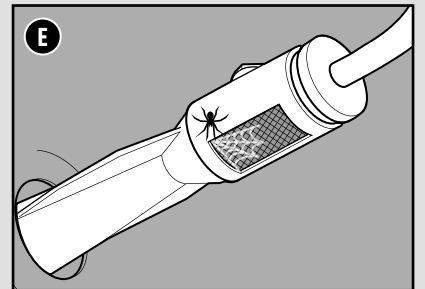

⚠ **WARNING:** Do not attempt to make any repair to gas carrying, gas burning, ignition components or structural components without contacting Weber-Stephen Products LLC, Customer Service Department.

⚠ **CAUTION:** The burner tube openings must be positioned properly over the valve orifices.

Inspect the Hose

Routine inspection of the hose is necessary.

- 1) Confirm that the grill is off and cool.
- 2) Check hose for any signs of cracking, abrasions, or cuts (H). If the hose is found to be damaged in any way, do not use the barbecue.

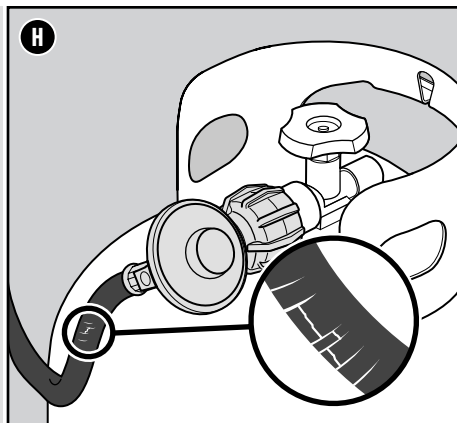

⚠ **WARNING:** If the hose is found to be damaged in any way, do not use the grill. Replace using only WEBER authorized replacement hose.



TROUBLESHOOTING

GRILL WILL NOT IGNITE

SYMPTOM

- Burner does not ignite when following the ignition instructions in the “Operation” section of this Owner’s Manual.

CAUSE

There is a problem with gas flow.

SOLUTION

If the grill will not ignite, the first step is to determine if there is gas flowing to the burners. To check this, follow the instructions below for “Using a Match to Determine if there is Gas Flow to the Burners.”

If **match lighting IS NOT successful**, follow the instructions for disconnecting and reconnecting the LP tank.

There is a problem with the ignition system.

If the grill will not ignite, the first step is to determine if there is gas flowing to the burners. To check this, follow the instructions below for “Using a Match to Determine if there is Gas Flow to the Burners.”

If **match lighting IS successful**, check the condition of the battery (electronic ignition systems only) and check the wire connections of the Ignition System.

Using a Match to Determine if there is Gas Flow to the Burners

- 1) Open the grill lid.
- 2) Check that the burner control knob is in the off \bigcirc position. Check by pushing in and turning knobs clockwise.
Note: It is important that all burner control knobs are in the off \bigcirc position before turning on the LP tank. If they are not, the flow limiting device built into the regulator will activate, limiting the flow of gas from the LP tank.
- 3) Turn the LP tank on by slowly turning the tank valve counterclockwise; wait 60 seconds.
Note: It is important that the LP tank is turned on slowly. If it is opened too quickly, the flow limiting device built into the regulator will activate, limiting the flow of gas from the LP tank.
- 4) Strike a match and put the flame under the matchlight hole (A).
- 5) While holding lit match, push the main burner control knob in and turn it counterclockwise to the start/high ⦿ position.
- 6) Check that the burner is lit by looking through the cooking grates.
- 7) If the burner does not ignite within 5 seconds, turn burner control knob to the off \bigcirc position and wait five minutes to allow the gas to clear before attempting to light the burner again.
- 8) If the burner ignites, the problem lies in the ignition system. For piezo igniters, check the wire connections of the Ignition System (B). For electronic ignition systems, check the condition of the battery and check the wire connections of the Ignition System (C). Verify that the AAA battery (alkaline only) is in good condition and is installed correctly. Some batteries have a plastic protective wrap around them. This plastic must be removed before installing battery. Do not confuse this plastic with the battery label.

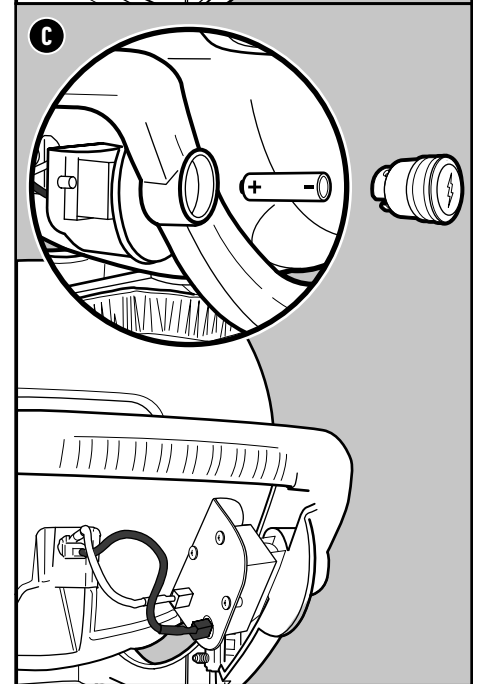
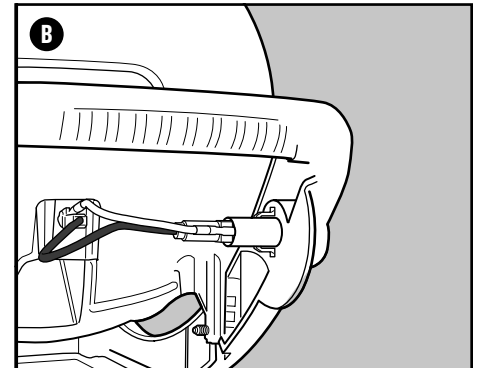
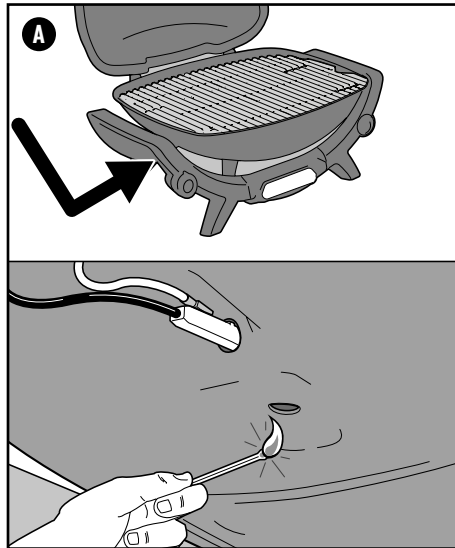

REPLACEMENT PARTS

To obtain replacement parts,
contact the local retailer
in your area or log onto weber.com.

CALL CUSTOMER SERVICE

If you are still experiencing any
problems, contact the Customer Service
Representative in your area using the
contact information on weber.com.

PROBLEMS? QUESTIONS? Do Not Return Product to the Store. We Can Help.

If you have questions about the assembly, use, or maintenance of your grill or need replacement parts, please contact Weber Customer Service. The serial number and model number can be found on the cover of your owner’s manual and will be necessary for all service calls.

U.S.:
1-800-446-1071

Canada:
1-800-446-1071

Mexico:
01 800 0093237

© 2023 Designed and engineered by Weber-Stephen Products LLC, 1415 S. Roselle Road, Palatine, Illinois 60067 USA.