



Operating and Installation Instructions Built-in Coffee System



To prevent accidents and machine damage, you **must** read these instructions before installation or use.

Contents

IMPORTANT SAFETY INSTRUCTIONS	6
Preparing your appliance for an extended vacation.....	13
Appliance description	16
Front view	16
Interior view.....	17
The milk flask.....	18
Central spout with cup rim sensor	18
Symbols on the display	19
Operation	20
Touch display.....	20
Operating actions.....	21
Miele@home	24
Initial commissioning	25
Before using for the first time.....	25
Turning on for the first time.....	25
Setting up the bean system.....	28
The bean system	30
Changing the bean system settings (Type of beans).....	30
Renaming types of beans	30
Changing how the bean containers are allocated.....	31
Filling the water tank	32
Switching on and off	33
Switching the coffee machine on.....	33
Switching the coffee machine off	33
Preparing for an extended period of inactivity	33
Preparing beverages	34
Coffee.....	34
Coffee drinks in detail	34
Milk and milk alternatives.....	34
Filling and inserting the milk flask	35
Making a coffee drink.....	36
Canceling a drink.....	36
DoubleShot.....	36
Making 2 portions ☐.....	36
Preparing a pot of coffee	37
Tea	37
Making tea	38
Starting the TeaTimer manually.....	38
Preparing a pot of tea.....	39

Dispensing warm or hot water	39
Expert Mode	40
Switching Expert mode on and off.....	40
Expert mode: allocating bean containers	40
Expert mode: changing the portion size	40
Grinder setting	41
Identifying the ideal grinder setting.....	41
Adjusting the fineness of grind.....	41
Parameters	42
Type of beans.....	42
Amount of coffee	42
Pre-brewing ground coffee	42
Brewing temperature for coffee drinks.....	42
Dispensing temperature for tea drinks, warm water, and hot water.....	42
Portion size.....	42
Displaying and changing parameters	43
Changing the portion size	43
Resetting drinks.....	44
Profiles	45
Profiles	45
Creating a profile	45
Processing a profile.....	45
Setting when the profile should change	45
MyMiele	47
MobileStart 	48
Preparing MobileStart 	48
Settings	49
Displaying and changing settings	49
Language.....	49
Time.....	49
Date	49
Start screen.....	49
Timer	50
Appliance timer	50
Maintenance timer	51
TeaTimer.....	51
Volume	51

Contents

Display	51
Brightness.....	51
Color scheme	51
QuickTouch.....	51
Lighting.....	51
Info (display information)	52
Fresh water.....	52
Altitude.....	52
Performance Mode	52
Eco Mode.....	52
Barista Mode.....	52
Latte Mode	52
Party Mode.....	52
Water hardness.....	53
MotionReact	54
System lock 	54
Miele@home	54
Performing Scan & Connect.....	55
Remote control	55
SuperVision	55
RemoteUpdate	56
Software version.....	57
Legal information	57
Showroom program (Demo mode).....	57
Factory default settings.....	57
Cleaning and care	58
Overview of cleaning intervals.....	58
Clean by hand or in dishwasher	59
Unsuitable cleaning agents.....	60
Opening the appliance door	60
Cleaning the drip tray and grounds container	61
Cleaning the drip tray cover.....	62
Cleaning the water container.....	63
Cleaning the central spout	63
Cleaning the cup rim sensor	65
Cleaning the milk flask with lid	65
Cleaning the milk valve (daily)	66
Cleaning the milk valve (once a month)	66
Cleaning the bean containers.....	69
Cleaning the brew unit and interior by hand	70
Cleaning the interior, inside of the appliance door, and drip tray.....	72
Cleaning the appliance front.....	73

Maintenance programs	73
Opening the Maintenance menu	73
Rinsing the machine.....	73
Rinsing the milk pipework	73
Clean the milk pipework.....	73
Degreasing the brew unit	74
Descaling the appliance	77
Automatic cleaning and descaling	79
What to ensure before and during automatic maintenance programs.....	79
Automatic cleaning	80
The Miele Cleaning Cartridge.....	80
Replacing the cleaning cartridge.....	81
Automatic descaling	82
The Miele descaling cartridge	82
Replacing the descaling cartridge.....	83
Removing the descaling cartridge.....	83
Inserting the descaling cartridge.....	83
Choosing not to use a descaling cartridge.....	84
Maintenance Timer	84
Canceling automatic cleaning and descaling	84
Frequently asked questions.....	85
Messages in the display	85
Unusual performance of the coffee system	88
Faults with automatic cleaning and/or descaling	91
Unsatisfactory results.....	92
Service and warranty.....	95
Contact in the event of a fault	95
Appliance warranty and product registration	95
Accessories	96
Caring for the environment	97
Saving energy.....	97
Installation	98
Plumbed water connection.....	98
Electrical connection	99
Installation dimensions	100
Building in the coffee machine	102
Technical data	104
FCC Declaration of Conformity.....	105
Copyrights and licenses	106

IMPORTANT SAFETY INSTRUCTIONS

This coffee machine complies with all the stipulated safety requirements. Inappropriate use can, however, lead to personal injury and material damage.

Read the operating instructions carefully before using the coffee machine. They contain important information on safety, installation, use, and maintenance. This prevents both personal injury and damage to the coffee machine.

Miele expressly and strongly advises you to read and follow the instructions in the chapter on installing the coffee machine as well as the safety instructions and warnings.

Miele cannot be held liable for injury or damage caused by non-compliance with these instructions.

Keep these operating instructions in a safe place and pass them on to any future owner.

IMPORTANT SAFETY INSTRUCTIONS

Appropriate use

- ▶ This coffee machine is intended for household use.
- ▶ Do not use the coffee machine outdoors.
- ▶ This coffee machine must not be used at altitudes above 6560 ft (2000 m).
- ▶ Persons who lack physical, sensory or mental abilities or experience with the machine should not use it without supervision or instruction by a responsible person.

IMPORTANT SAFETY INSTRUCTIONS

Safety with children

 Danger of burning and scalding at the dispensers.

Children's skin is far more sensitive to high temperatures than that of adults.

Ensure children do not touch hot surfaces of the coffee machine or place parts of their body under the dispensers.

- ▶ Keep the coffee system out of reach of children.
- ▶ Children must be kept away from the coffee machine unless they are constantly supervised.
- ▶ Children should be supervised when they are near the coffee system. Do not allow them to play with it or to use the controls.
- ▶ Children must not be allowed to clean the coffee machine unsupervised.
- ▶ Remember that coffee and espresso are not suitable drinks for children.
- ▶ Danger of suffocation. While playing, children may become entangled in packaging material (such as plastic wrapping) or pull the packaging material over their head, presenting the risk of suffocation. Keep packaging material away from children.

IMPORTANT SAFETY INSTRUCTIONS

Technical safety

- ▶ Installation work or repairs should only be carried out by a Miele authorized technician. Unauthorized or incorrect installation work or repairs can pose considerable danger to users.
- ▶ A damaged coffee system could be dangerous. Before building in the machine, check it for any externally visible damage. Do not use a damaged machine.
- ▶ Before connecting the coffee system, check the voltage and frequency indicated on the data plate against the voltage and frequency of the household electrical supply. This data must correspond in order to prevent damage to the coffee system. If in doubt, consult a qualified electrician.
- ▶ Be certain your appliance is properly installed and grounded by a qualified technician. To guarantee the electrical safety of this appliance, continuity must exist between the appliance and an effective grounding system. It is imperative that this basic safety requirement be met. If there is any doubt, have the electrical system of the house checked by a qualified electrician.
- ▶ Reliable and safe operation of the coffee system can only be guaranteed if it is connected to the electrical supply.
- ▶ Do not connect the machine to the electrical supply using an extension cord or power bar.
- ▶ The coffee machine may not be used in mobile installations such as ships.
- ▶ For safety reasons, this machine may only be used when it has been built in.
- ▶ Do not place on or near a hot gas or electric burner, or in a heated oven.
- ▶ Unplug the coffee machine from the power supply immediately if you notice any damage or smell burning.
- ▶ Ensure that the power cord will not be pinched or damaged by any sharp edges.
- ▶ To reduce the risk of injury, do not drape cord over the counter top or table top where it can be pulled on by children or tripped over unintentionally.

IMPORTANT SAFETY INSTRUCTIONS

▶ Do not operate any appliance with a damaged cord or plug or after the appliance malfunctions, or has been damaged in any manner. Return appliance to the nearest authorized service facility for examination, repair or adjustment.

▶ To protect against fire, electric shock and injury to persons do not immerse cord or plugs in water or other liquid.

▶ To reduce the risk of fire:

- Do not place any heating or cooking appliance beneath the appliance without a shelf in between.
- Do not mount unit over or near any portion of a heating or cooking appliance without a shelf in between.
- Do not mount over a sink.
- Do not store anything directly on top of the appliance surface when the appliance is in operation.

▶ If the coffee machine is to be built in above another appliance, there must be a full-width, closed shelf between them (except when it is combined with a Gourmet warming drawer or a built-in vacuum drawer).

▶ Only use the coffee system in rooms where the ambient temperature is between +60°F (16°C) and +100°F (38°C).

▶ For repairs, the coffee system must be disconnected from the electrical power supply.

The coffee system is only disconnected from the power supply if

- the circuit breaker has been tripped, or
- the fuse is removed, or
- the power cord is disconnected from the power supply.

Pull the plug, not the cord, to disconnect the appliance from the power supply.

▶ The manufacturer's warranty may be invalidated if the appliance is not repaired by a Miele approved service technician from Technical Service.

▶ Never open the outer casing of the machine. Tampering with electrical connections or components and mechanical parts is highly dangerous to the user and can cause operational faults or electric shock.

IMPORTANT SAFETY INSTRUCTIONS

Plumbed water connection

- ▶ Do not connect the coffee system to a hot water supply.
- ▶ The non-return valve must be easily accessible when the coffee system is built in.
- ▶ The protective sleeve of the water intake hose must not be damaged or become kinked. This will cause it to leak.
- ▶ The integrated water protection system offers protection from water damage, provided the following conditions are met:
 - The coffee machine is correctly installed, connected to the electricity supply, and plumbed in.
 - If a fault is identified, the coffee machine must be repaired immediately.
 - The water supply valve is turned off when the appliance is not in use for an extended period (e.g., vacation).

IMPORTANT SAFETY INSTRUCTIONS

Correct use

- ▶ Please note the following regarding water:
 - The water quality must conform to the requirements for drinking water in the country in which the coffee machine is being used.
 - When using the water container: Only use cold, fresh tap water to fill the water container. Hot or warm water or other liquids can damage the coffee machine.
 - Change the water every day to prevent a build-up of bacteria. When using a plumbed-water connection: empty the water container once a day.
 - Do not use sparkling water.
- ▶ Only put roasted coffee beans in the bean containers. Do not place coffee beans which have been treated with additives or ground coffee inside the bean containers.
- ▶ Do not fill the bean containers with any type of liquid.
- ▶ Do not use green (unroasted) coffee beans or mixtures of coffee beans which contain green coffee beans. Green coffee beans are very hard and still contain residual moisture. These can damage the coffee machine grinder as soon as grinding begins.
- ▶ Do not use oily beans or beans that have been treated with caramel, sugar, or other substances. Sugar and oil will damage the coffee system.
- ▶ If decaffeinated coffee beans are used after dispensing a drink with caffeinated beans, there may still be residues from the caffeinated beans in the grinder or brew chamber. Discard the first coffee drink when using decaffeinated coffee.
- ▶ Only use plain milk. Most sugary additives can clog the milk lines and damage the machine.
- ▶ If using dairy milk make sure that it has been pasteurized.
- ▶ When making tea, please follow the instructions on the tea packaging.
- ▶ Do not place flaming alcohol mixtures underneath the central spout. The flames could ignite plastic components and cause them to melt.
- ▶ Do not swing from or hang anything on the machine front when it is open as this could damage the hinges of the machine.

IMPORTANT SAFETY INSTRUCTIONS

- ▶ Do not use the coffee system to clean objects.

Preparing your appliance for an extended vacation

- ▶ If you elect to turn off the water to your home for an extended period of time, please note that this may not be enough to reduce the risk of a leak. To be completely safe, you must turn off the water supply to each individual appliance. This means under the sink for a dishwasher, at the laundry bib for your washer, etc.
- ▶ Make sure that the coffee machine does not come into contact with hand sanitizer or sunscreen, as this will damage the surfaces.

IMPORTANT SAFETY INSTRUCTIONS

Accessories and parts

- ▶ Only use genuine Miele accessories. If other parts are used, warranty, performance, and/or product liability claims may be invalidated.
- ▶ The use of accessory attachments not recommended by the appliance manufacturer may result in fire, electric shock or injury to persons.
- ▶ Miele can only guarantee the safety of the appliance when genuine Miele replacement parts are used. Faulty components should only be replaced by genuine Miele replacement parts.

IMPORTANT SAFETY INSTRUCTIONS

Cleaning and maintenance

- ▶ Unplug from outlet when not in use and before cleaning. Allow to cool before putting on or taking off parts, and before cleaning the appliance.
- ▶ Clean the coffee machine and the milk flask daily, particularly before using for the first time.
- ▶ All parts of the milk system need to be cleaned thoroughly and regularly.
- ▶ If you do not make use of the automatic descaling and cleaning functions, you must regularly run the maintenance programs for cleaning the milk pipework and the brew unit, and for carrying out descaling. Miele cannot be held liable for damage that results from not cleaning and/or descaling the machine properly, or from using the wrong cleaning/descaling agent, or an unsuitable solution concentration.
- ▶ Do not use a steam cleaner to clean this machine. Steam could reach electrical components and cause a short circuit.
- ▶ Rinsing coffee grounds down the drain can cause the sink to clog. Instead, dispose of your coffee grounds appropriately as biodegradable waste (where facilities exist) or by composting.

For machines with stainless steel surfaces:

- ▶ Do not use sticky notes, transparent adhesive tape, masking tape, or other types of adhesive on the stainless steel surfaces. These will damage the stainless steel surfaces, causing them to lose their dirt-repellent protective coating.
- ▶ The finish on stainless steel surfaces is susceptible to scratching. Even magnets can cause scratching.

SAVE THESE INSTRUCTIONS

Appliance description

Front view

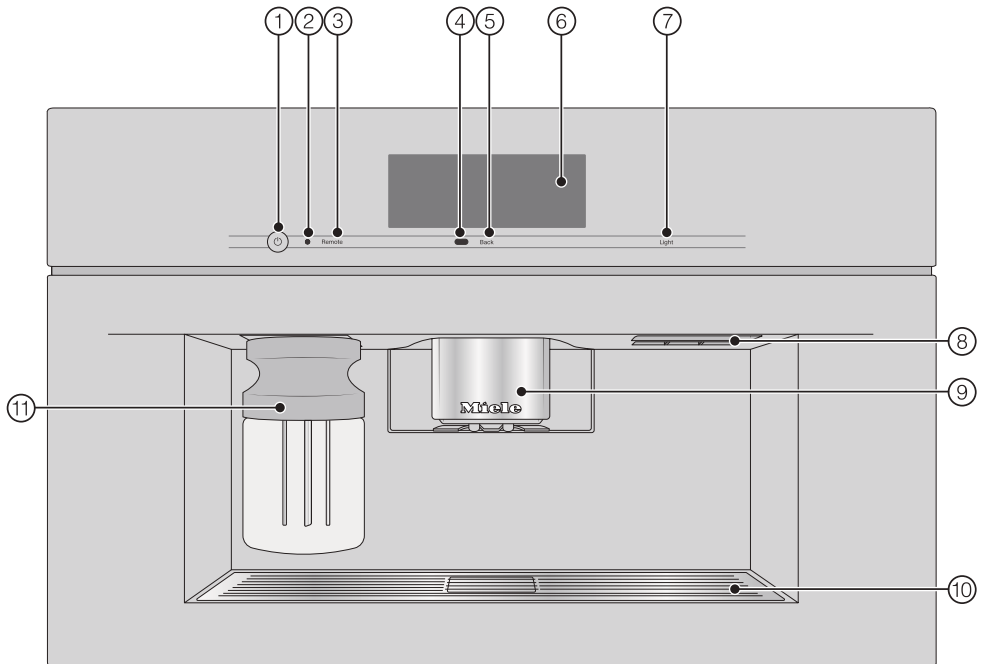

- ① On/Off button ①
- ② Optical interface (for Miele Technical Service only)
- ③ *Remote* sensor button (MobileStart)
- ④ Movement sensor
- ⑤ *Back* sensor button
- ⑥ Touch display
- ⑦ *Light* sensor button
- ⑧ Door handle
- ⑨ Height-adjustable central spout with lighting
- ⑩ Drip-tray cover
- ⑪ Milk container

Interior view

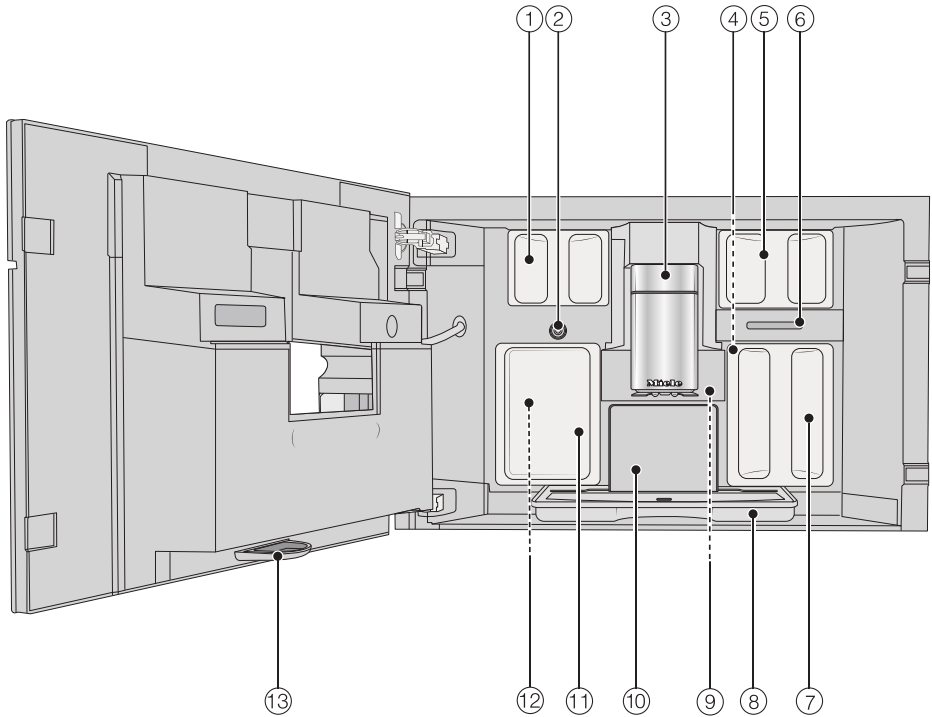

- ① Bean containers (Type A and Type C)
- ② Milk valve
- ③ Height-adjustable central spout with lighting
- ④ Grinder setting
- ⑤ Bean container (Type B)
- ⑥ Fan outlet
- ⑦ Water container
- ⑧ Drip tray with lid
- ⑨ Brew unit
- ⑩ Grounds container
- ⑪ Maintenance container
- ⑫ Holders for cleaning and descaling cartridges (including adapters)
- ⑬ Drip tray

Appliance description

The milk flask

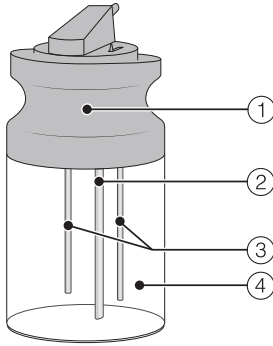

- ① Lid
- ② Milk intake tube
- ③ Sensor rod
- ④ Glass flask

Central spout with cup rim sensor

The central spout with cup rim sensor features automatic spout adjustment. Thanks to this spout adjustment function, the central spout moves down automatically at the start of a drink preparation process and the cup rim sensor stops it at the optimum height for the cups or glasses being used.

The central spout and cup rim sensor **cannot** be manually adjusted.













When the coffee machine is switched off, the central spout will be in the middle position.

When a maintenance program is being carried out, the central spout will move to the height of the maintenance container or into a low maintenance position.

Make sure that the main position is in the top or middle position before you open the door.

Symbols on the display

The display shows symbols as well as text.

Symbol	Explanation
	This symbol indicates that there is additional information and advice about using the coffee machine. Select <i>OK</i> to confirm the messages.
	This symbol indicates the Settings menu and the Language menu option.
	The symbol is displayed when the system lock is switched on. The controls are locked.
	The symbol and the desired switching-on time appear in the display 23:59 hours before the coffee machine is due to switch on if the <i>On at timer</i> and setting for displaying the time are activated.
	This symbol appears during the <i>Clean the milk pipework</i> maintenance program and during automatic cleaning. This symbol is also found on the water container: Fill up to this mark with water.
	This symbol appears while the appliance is being descaled. This symbol can also be found on the water container: Fill up to this mark.
	This symbol and a fault code will appear if a fault occurs.
	If Miele@home has been activated for the coffee machine, these symbols represent the quality of the Wi-Fi connection. They indicate the strength of the Wi-Fi connection in increments from strong to not connected.
	The “MobileStart” sensor control lights up if Miele@home is set up for the coffee machine and MobileStart is switched on. If the  sensor control only flashes, the coffee machine is not yet connected to the network. When the coffee machine is ready for operation, you can start networking it at any time by briefly touching the  sensor control.
	The “SuperVision” symbol appears if Miele@home has been set up for the coffee machine and the setting <i>SuperVision SuperVision display On</i> has been selected.

Operation

Touch display

The delicate touch display can be scratched by pointed or sharp objects, e.g., pens.

Only touch the display with your fingers.

The touch display is split into multiple areas.

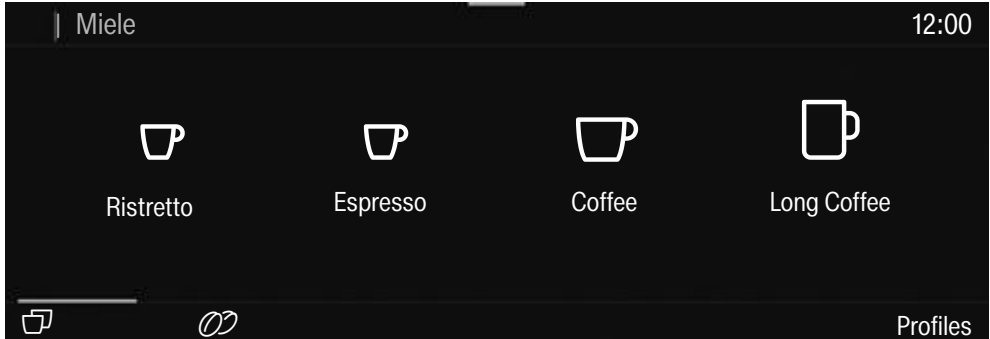

The menu path appears on the left of the **header**. If you tap a menu name in the header, the display will switch to that menu. To switch to the start screen, tap .

The time of day is shown on the right of the header. Additional symbols may also appear, e.g., TeaTimer .

The current menu and menu options are shown in the **center** of the display. You can scroll to the right or left by swiping your finger across the display to the right or left.

The options that appear in the **footer** vary according to which menu is selected; e.g., DoubleShot , Save, or OK.

Operating actions

All the selectable options are displayed in black or white according to your selected color scheme.

Each time you tap a possible option, the relevant characters (word and/or symbol) light up **orange**.

Selecting a menu option

- Touch the desired menu option or value in the touch display.

Scrolling

You can scroll left or right.

- Swipe across the screen. To do this, place your finger on the touch display and swipe it in the direction you want.

The bar at the bottom shows you where you are in the current menu.

Exiting a menu

- Tap the *Back* sensor button. Alternatively, tap the higher-level menu name within the menu path.

Entries made before this which have not been confirmed with *OK* will not be saved.

Tip: Tapping the *Back* sensor button three times in succession will take you to the drinks menu.

Entering numbers with the roller

- Swipe the roller up or down until the value you want is displayed centrally in orange.
- Confirm with *OK*.

Operation

Entering numbers using the numerical keypad

- Tap the centrally displayed orange value and keep your finger on it until the numerical keypad appears.

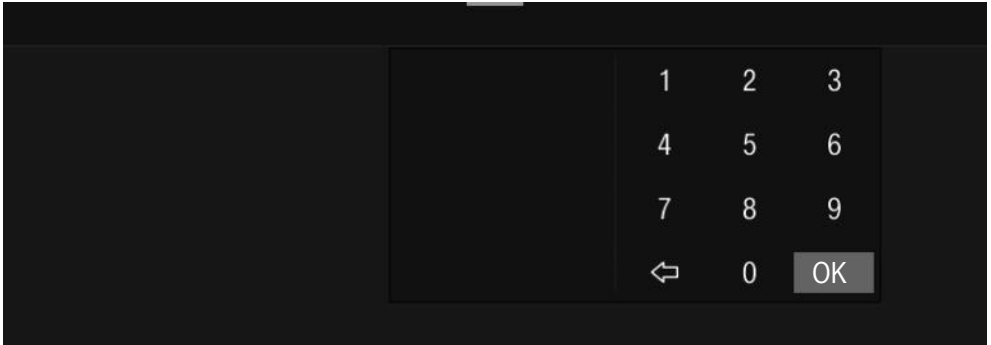

- Select the value you want: as soon as you enter a valid value, *OK* turns green. Use the ↶ arrow to delete the last entered number.
- Confirm with *OK*.

Entering a name

Letters are entered using a keyboard. It is best to select short names.

- Tap the letters or characters you want.

Tip: Use the ↶ arrow to delete the last entered character.

- Tap *Save*.

Displaying the context menu

When you are in certain menus, a context menu can be displayed, e.g., for configuring drinks.

- For instance, you can tap the name of a drink and keep your finger on it until the context menu opens.
- To close the context menu, tap an area of the display located outside of the menu window.

Moving entries

You can change the order of the entries in the drinks menu, in *Profiles*, and in *MyMiele*.

- Touch an entry and keep your finger on it until the context menu appears.
- Select *Move*.

An orange border appears around the entry.

- Tap the selected entry and keep your finger on the display. Drag the entry to the required position.

Help

Context-sensitive help is available for certain functions. In this case, Help appears in the bottom line.

- Tap Help to display information in text and pictures.
- Tap Close to return to the previous menu.

Pull-down menu

Among other things, the pull-down menu provides access to a schematic representation of the bean containers and to Expert Mode.

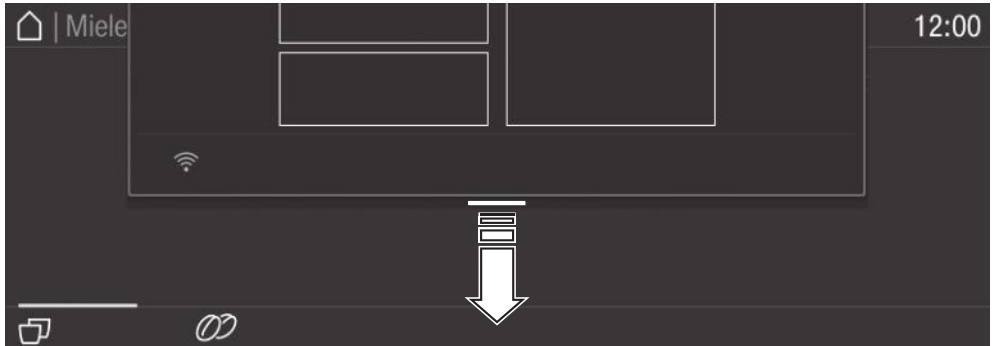

- Tap the orange line at the top edge of the screen and drag down with your finger.

Active settings are highlighted in orange.

- To close the pull-down menu, drag it back up to the top or tap an area of the display located outside of the menu window.

Your coffee machine is equipped with an integrated Wi-Fi module.

Before installing the coffee machine at its installation site, ensure that the signal from your Wi-Fi network is strong enough.

To use this feature, you will need:

- a Wi-Fi network
- the Miele app
- a Miele user account (this can be created from the Miele app)

The Miele app will guide you through the process of connecting your coffee machine to your home Wi-Fi network.

Once your coffee machine is connected to your Wi-Fi network, you can use the app to carry out activities such as the following:

- install software updates
- call up information on the operating status of your coffee machine
- change settings on your coffee machine
- control your coffee machine remotely

Connecting your coffee machine to your Wi-Fi network will increase energy consumption, even when the machine is switched off.

Availability of the Wi-Fi connection

The Wi-Fi connection shares a frequency range with other appliances (including microwave ovens and remote control toys). This can cause sporadic or even complete connection failures. Therefore, the availability of featured functions cannot be guaranteed.

Miele@home availability

The ability to use the Miele app depends on the availability of the Miele@home service in your country.

The Miele@home service is not available in every country.

For information about availability, please visit www.miele.com.

Miele App

The Miele App is available to download free of charge from the Apple App Store® or from the Google Play Store™.



Before using for the first time

- Connect the coffee machine to the plumbed-water and power supplies.
- Install the coffee machine.
- Remove any notices from the machine.
- Remove the protective foil from the drip-tray cover.
- Clean the water container, bean containers, and the central spout.

Have the following to hand (included with delivery) when setting the machine up for the first time:

- Miele Cleaning Cartridge
- Miele Descaling Cartridge

Turning on for the first time

- Tap the On/Off button .

Selecting the display language

- Select the desired display language.

You might also be asked for your location.

The choice of location determines how the time of day is displayed, e.g., in the 12 or 24-hour format, as well as how units are displayed and so on.

Setting up the network (Miele@home)

To receive software updates and operate the coffee machine via the Miele app on your mobile device, you can connect your coffee machine to your home Wi-Fi network.

The following appears in the display during commissioning: Set up Miele@home?

Tip: You can also set up Miele@home at a later time by scanning the QR code on the inside of the appliance door (see “Setting up Scan & Connect”). In this case, select Skip.

- Make sure that your Wi-Fi network signal is sufficiently strong in the coffee machine’s final installation site.
- Tap Continue.
- Select the connection method you wish to use.
- Follow the instructions provided in the coffee machine display and in the Miele app.

Connection successfully established appears in the display.

Any new software that is available for your coffee machine will be downloaded via RemoteUpdate the next time the appliance is switched on. In this case, you will be notified that you can install the new software (see “RemoteUpdate” section).

Networking increases the energy consumption of the coffee machine.

- Touch Continue to proceed with commissioning.

Setting the date

- Set today’s date.
- Confirm with *OK*.

Setting the time of day

- Set the current time of day.
- Confirm with *OK*.

If the coffee machine has been connected to a Wi-Fi network and signed into the Miele app, the time will be synchronized based on the location setting in the Miele app.

Initial commissioning

Setting the water hardness

Your local water authority will be able to tell you the hardness of the water in your area.

More information can be found under “Settings – Water hardness”.

- Enter your local water hardness (in °dH) and confirm with *OK*.

Selecting the water supply (Main Water)

The coffee machine is intended to be plumbed into the water supply. You can choose between the following water supply options:

- **On:** The water container will be filled automatically via the plumbed water connection.
- **Off:** You must fill the water container manually. A message appears in the display to inform you of this.

- Select the option you want.

Setting up automatic cleaning and descaling

Information about automatic cleaning and descaling will appear in the display.

- Confirm with *OK*.

Tip: Tap *Help* to display an illustrated guide.

Inserting the cleaning cartridge

You will now be prompted to insert the cleaning cartridge.

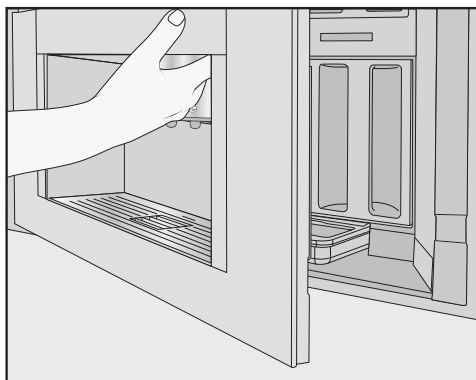

- Open the appliance door.

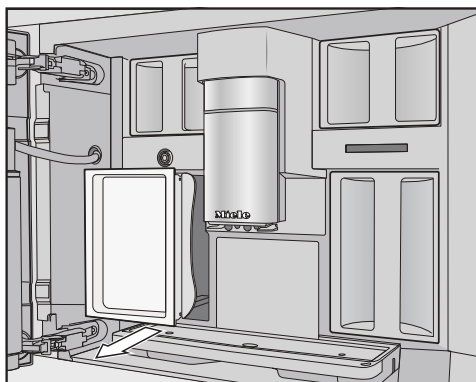

- Remove the maintenance container on the left-hand side.

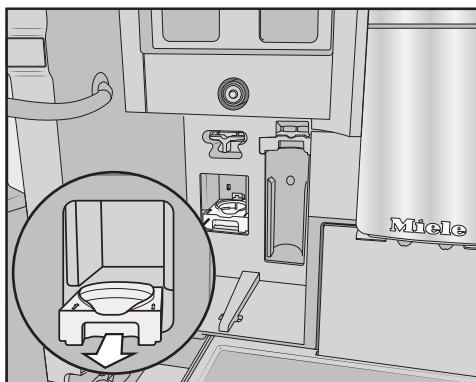

- Pull the cleaning cartridge holder forward to remove it.

Initial commissioning

- Take the cleaning cartridge out of its packaging.
- Unscrew the screw cap.

The screw cap is no longer required.

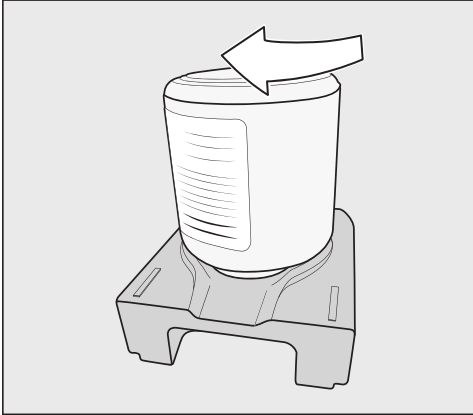

- Screw the cleaning cartridge into the holder upside down.
- Push the holder and cartridge into the coffee machine until the holder audibly clicks into place.

Inserting the descaling cartridge

- Take the descaling cartridge out of its packaging.

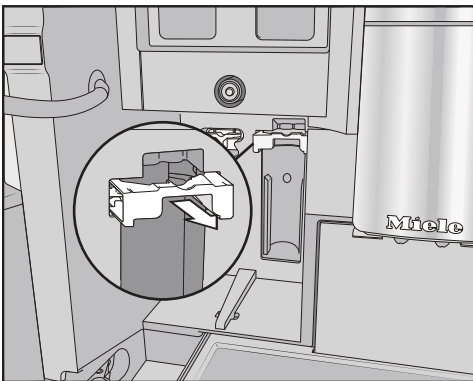

- Pull the descaling cartridge holder forward.

- Insert the descaling cartridge and push it upward as far as it will go.
- Slide the descaling cartridge holder back into place.
- Put the maintenance container back inside the appliance.
- Close the appliance door.

The descaling cartridge will fill with water the next time the machine is switched off.

Always wait for the coffee machine to switch itself off. Do not force the machine to switch off.

Changing the start time

Once the cleaning and descaling cartridges have been inserted, a message will appear regarding the current start time set for automatic cleaning and descaling.

- If you want to change the start time, tap **Timer**.
- Select the time you want.
- Confirm with **OK**.

You can change the start time for automatic cleaning and descaling at any time.

Selecting the Performance Mode

You can select the appropriate Performance mode to suit your personal preferences (see “Customizing settings – Performance mode”).

- **Eco Mode:** This mode consumes the least amount of energy (default setting).
- **Barista Mode:** This mode has been optimized for unadulterated coffee enjoyment.

Initial commissioning

- **Latte Mode:** In this mode, milk-based drinks can be prepared within a much shorter space of time.

- Select the Performance mode you want.

Selecting a Performance mode other than Eco Mode increases the energy consumption of the coffee machine.

The coffee machine is now successfully set up for use. You can now set up the bean system.

Setting up the bean system

After setting up the coffee machine, you will be prompted to set up the bean system. The coffee machine will assist you when first filling and naming the bean containers.

- Tap Yes.

If you select No, the assistant for setting up the bean system will not be shown again.

Filling the bean containers

The coffee machine has 2 bean container drawers on the top left and right.

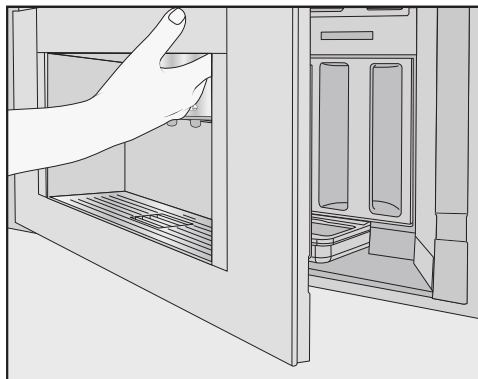

- Open the appliance door.

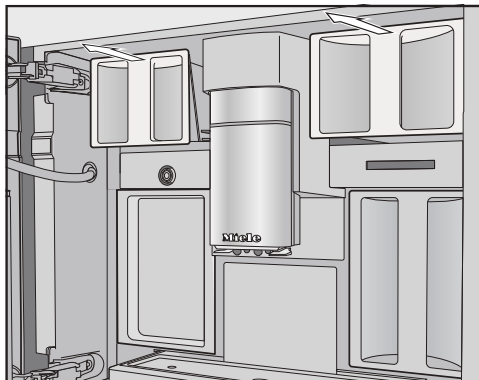

- Pull the bean containers out and take off the lids.
- Fill the bean containers with roasted coffee beans.
- Put the lids back on the bean containers to seal them.
- Push the bean containers all the way back into the coffee machine. Close the appliance door.

Tip: Make a note of each type of bean. After filling the bean containers, you can now name the types of beans.

Naming the types of beans

The 3 bean containers are shown in the display as follows and are pre-named.

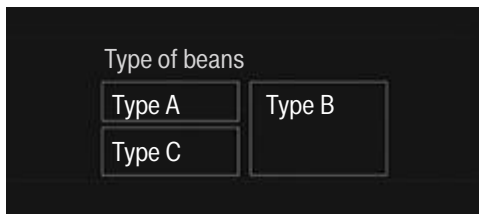

If you rename the bean containers, please note the following:

- It is best to select short names.
- If you are using the same type of beans in 2 or all bean containers at the same time (for instance, because

you only use one type of beans), make sure you name them in the exact same way.

Name type of beans for bean container? appears in the display and Type A is highlighted in orange.

- Tap Yes.

The editor will open in the display.

- Enter the name you want for the bean container.

- Tap Save.

- Now name the other 2 bean containers.

<Type XY> Allocate will appear in the title bar of the display.

Allocating the types of beans

Allocate the individual types of beans to the coffee drinks you would like.

- Select the drinks that are to be prepared with this type of bean.

The selected drinks are marked in orange.

- Confirm with *OK*.

Now it is time to allocate the next type of bean. The coffee drinks that have not yet been allocated are displayed.

- Select the drinks that are to be prepared with this type of bean.

- Confirm with *OK*.

Any remaining drinks which have not been selected will be allocated to the third type of beans.

You have set up the bean system and you can now prepare drinks.

Tip: Tap *All drinks* to select all the drinks. You can then deselect the ones you do not want.

If you do not allocate the bean containers to the drinks, you will be asked what type of bean you want to use for the coffee as you make it.

To ensure that any coffee residues from the factory testing process are removed from the brewing system, please throw away the first 2 cups of coffee when using the coffee machine for the first time.

The bean system

Coffee or espresso can be made from whole roasted coffee beans which are freshly ground for each cup. Your coffee machine has a bean system with 3 bean containers which can be filled with different types of beans or even just one type. You can allocate bean types to individual coffee drinks as you wish. Alternatively, you can create profiles with your own coffee drinks and allocate other bean types to these drinks which are different to the standard Miele profiles.

 Risk of damage to the grinder due to incorrect operation.

The coffee machine will be damaged if the bean container is filled with unsuitable substances such as liquids, ground coffee, or coffee beans treated with sugar, caramel, or similar.

In addition, green (unroasted) coffee beans or mixtures of coffee beans which contain green coffee beans can damage the grinder. Green coffee beans are very hard and still contain residual moisture. These can damage the coffee machine grinder as soon as grinding begins.

Only put roasted coffee beans in the bean container.

If decaffeinated coffee beans are used after dispensing a drink with caffeinated beans, there may still be residues from the caffeinated beans in the grinder or brew chamber.

Please be aware that minimal residues of caffeine may be present in the next drink that you make.

Changing the bean system settings (Type of beans)

The drinks menu is displayed.

- Touch the ↶ sensor control.
- Select Settings.
- Select Type of beans.

The schematic representation of the bean containers is displayed.

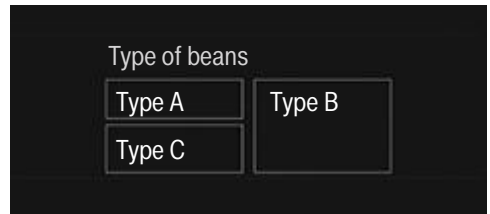

- Select a type of beans.

You can now change the name of the type of beans or how it is allocated.

Tip: If you want to allocate another type of bean to a coffee drink, you can also do this under “Change parameters” (see “Parameters – Type of beans”).

Renaming types of beans

If you rename the types of beans, please note the following:

- It is best to select short names.
- If you are using the same type of beans in 2 or all bean containers at the same time (for instance, because you only use one type of beans), make sure you name them in the exact same way.

- Tap Change name.

The editor will open in the display.

- Enter the name you want.
- Tap Save.

If you switch from having identical names to having different names, you will then need to allocate coffee drinks to the newly named type of bean.

Changing how the bean containers are allocated

If you have created extra user profiles for coffee drinks in addition to the Miele standard profile, the types of beans can be individually allocated to the drinks in each profile.

- Tap Change allocation.

If you have set up 1 or more profiles and at least 1 coffee drink, first select the profile.

- Select the profile for which you want to allocate the type of beans.

All coffee drinks will be listed. The already allocated drinks will be highlighted in orange.

- Change the allocation as required.
- Confirm with *OK*.

Tip: If you tap *All drinks*, you will highlight all coffee drinks and you can deselect the ones you do not want.

If you do not allocate a type of bean, you will be asked what type of bean you want to use for the coffee as you make it.

Filling the water tank

⚠ Risk to health due to contaminated water.

Bacteria can develop in water which has been sitting in the water container for too long and is a risk to your health. Water that gets left in the inlet hose can also impair the flavor if you do not make any drinks for a long time.

Change the water in the water container **every day**.

Discard the first full container of water if you have not made any drinks for a while.

If the coffee machine is plumbed into the drinking water supply, the water container will fill automatically as soon as the coffee machine is switched on. You can fill the water container manually at any time.

⚠ Risk of damage due to incorrect operation.

Unsuitable liquids such as hot or warm water or other liquids can damage the coffee machine.

Carbonated water leaves too much limescale in the coffee machine.

If filling the water container manually:
Only use fresh, cold tap water.

- Open the appliance door.

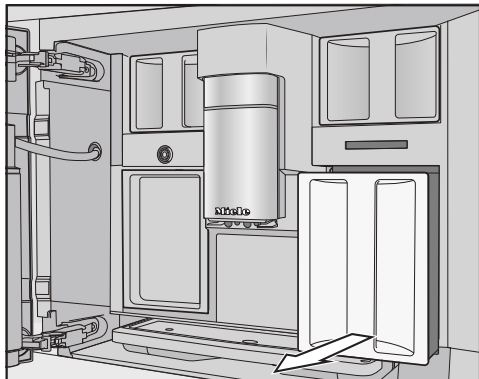

- Pull the water container forward to remove it.
- Fill the water container with fresh, cold drinking water up to the *max.* mark.
- Push the water container into the appliance.
- Close the appliance door.

Switching the coffee machine on

- Tap the On/Off switch ①.

The coffee machine heats up and rinses the pipework. Hot water will run out of the central spout.

You can now make drinks.

If the coffee machine is already at operating temperature, rinsing will not take place when the machine is switched on.

Switching the coffee machine off

- Tap the On/Off switch ①.

If coffee has been dispensed, the coffee machine will rinse the pipework automatically before switching off.

While dispensing a drink or during maintenance processes, moisture builds up in the coffee machine. Once a drink has been dispensed or the machine has been switched off, the internal fan will continue to run until the interior is sufficiently dehumidified. You will hear an accompanying noise.

Preparing for an extended period of inactivity

If the coffee machine is not going to be used for more than 3 days, such as during a vacation, proceed as follows:

- Empty the drip tray, the grounds container, and the water container.
- Clean all parts thoroughly, including the brew unit and appliance interior.
- Switch the coffee machine off.

Preparing beverages

 Danger of burning and scalding at the dispensers.

The liquids and steam dispensed are very hot and can cause scalding.

Keep away from the area underneath the dispensers when hot liquids and steam are being dispensed.

Do not touch hot components.

Coffee

Coffee drinks in detail

You can use the coffee machine to prepare the following coffee-based drinks:

- **Ristretto** is a concentrated, stronger espresso. It is prepared with the same amount of coffee as for an espresso but with a lot less water.
- **Espresso** is a strong aromatic coffee with a thick, hazelnut-brown colored froth – known as the crema – on top. We recommend using espresso-roasted coffee beans to make an espresso.
- **Coffee** differs from espresso by the increased amount of water and the roast of the beans. We recommend using coffee beans of the correct roast to make the coffee.
- **Lungo** is a coffee with significantly more water.
- **Long black** is made with hot water and two shots of espresso.
- **Caffè Americano** consists of equal proportions of espresso and hot water. The espresso is made first, then the hot water is dispensed.
- **Cappuccino** consists of approx. 2 thirds milk froth and 1 third espresso.

- **Latte macchiato** consists of 1 third each of hot milk, milk froth, and espresso.
- **Caffè latte** consists of espresso and hot milk.
- **Cappuccino Italiano** has the same proportions of milk froth and espresso as a cappuccino. The difference is that the espresso is added first and then the milk froth.
- **Espresso macchiato** is an espresso with a small amount of milk froth on top.
- **Flat white** is a special variety of capuccino that contains significantly more espresso than milk froth for an intensive coffee aroma.
- **Café au lait** is a French style of coffee consisting of coffee and milk froth. Café au lait is usually served in a bowl.

Hot milk and **milk froth** can also be made.

Milk and milk alternatives

Cow's milk or alternative plant-based dairy products (e.g., soy milk) containing added sugar can clog up the milk pipe and the rest of the milk pipework. Residues from unsuitable liquids can interfere with milk preparation.

The milk used must not contain any additives.

Dairy milk naturally contains bacteria. If using dairy milk, make sure that it has been pasteurized, e.g., pasteurized cow's milk.

You can prepare hot milk and milk froth using cow's milk or alternative plant-based dairy products. However, the

consistency of the milk froth will vary greatly depending on the type of milk used. Not all types of milk are suitable for milk froth.

Once the appliance has heated up, the milk will be drawn up into the central spout where it is heated by steam and also frothed for drinks requiring milk froth.

Tip: Using cold cow's milk (< 50°F/ 10°C) with a protein content of at least 3% will produce the perfect milk froth. You can select milk with a fat content according to your personal preference. With whole milk (at least 3.5% fat), the milk froth will be slightly creamier than with low-fat milk.

Alternative plant-based dairy products – hereafter referred to as “alternative dairy products” – contain different ingredients than cow's milk, for example. Due to natural settling, dairy products tend to thicken. When preparing hot milk or milk froth, this thicker consistency can prevent the alternative dairy products from being drawn into the milk pipework. Stir alternative dairy products well immediately before preparation. Do not shake alternative dairy products. Shaking causes foam to form in the packaging and impairs the preparation process.

Tip: Rinse the milk pipework manually immediately after preparation.

Filling and inserting the milk flask

Milk is **not** cooled in the milk flask. Milk may spoil if it is left in the milk flask for an extended period without being cooled (depending on the type of milk).

In particular, do not leave cow's milk in the milk flask for an extended period without cooling it.

Please follow the manufacturer's instructions regarding the shelf life of the milk used.

If you have not made any milk drinks for a while, rinse the milk pipework thoroughly before making the first drink.

Tip: For high-quality milk froth, always use cold milk (< 50°F/10°C).

- If you use alternative dairy products, make sure that you stir it well. To ensure the best preparation, alternative dairy products must be stirred and not shaken.
- Fill the milk flask with milk up to a maximum of 3/4" (2 cm) below the rim.
- Seal the milk flask with the lid.

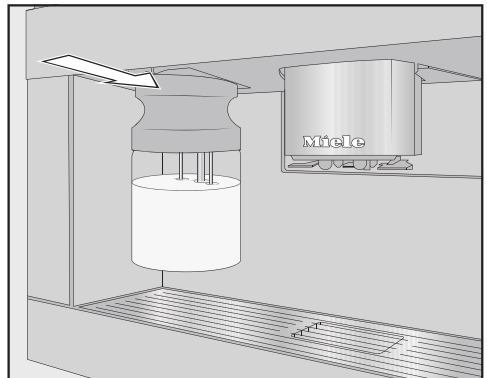

- Push the milk flask back into the coffee machine until it clicks into place.

Preparing beverages

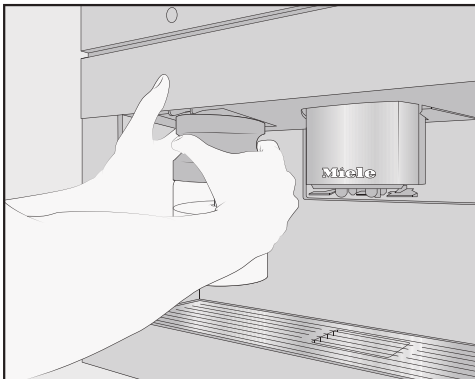

Tip: It is easier to remove the milk flask with both hands.

Making a coffee drink

If decaffeinated coffee beans are used after dispensing a drink with caffeinated beans, there may still be residues from the caffeinated beans in the grinder or brew chamber.

Please be aware that minimal residues of caffeinated beans from the previous drink may be present in the next drink that you make.

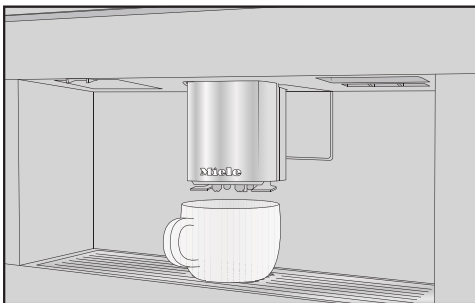

- Place a container under the central spout.
- If you want to make a coffee with hot milk or milk froth, prepare the milk flask and insert it into the appliance.
- Select a coffee drink.

Preparation will begin and the coffee will be dispensed into the container from the central spout.

Tip: If you have dispensed a coffee with milk, rinse the milk pipework manually after preparation.

Canceling a drink

- Press Stop or Cancel.

DoubleShot

Select the DoubleShot $\text{\textcircled{D}}$ function if you would like a particularly strong and aromatic coffee. In this case, more coffee beans will be ground and brewed halfway through brewing.

The shorter extraction time means that fewer unwanted aromas and bitter compounds will be released.

Making a DoubleShot $\text{\textcircled{D}}$ of coffee

The $\text{\textcircled{D}}$ symbol will appear while drinks are being made.

- Tap the $\text{\textcircled{D}}$ symbol immediately before or after you start making a drink.

Dispensing starts and the $\text{\textcircled{D}}$ symbol is highlighted in orange in the display. 2 portions of coffee beans will be ground and brewed.

Making 2 portions $\text{\textcircled{2}}$

You can dispense 2 portions of a drink into 1 large cup or into 2 cups at the same time.

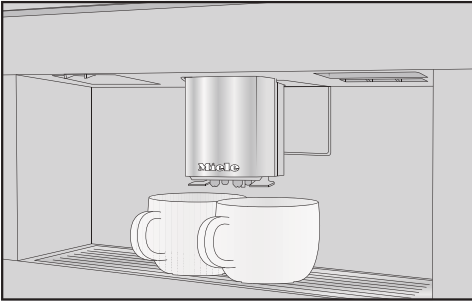

- Tap Cancel.

Tea

If the dispensing temperature is too high or too low or if the brewing time is too short or too long, this can affect the flavor of your tea.

Follow the instructions provided by the manufacturer of the tea you are making.

The coffee machine is not intended for commercial or scientific purposes. Dispensing temperatures given are approximate and can vary according to ambient conditions. A temperature increment of approximately 35°F (2°C) makes a noticeable difference.

When making tea, you can select from the following options:

- **Japanese Tea** is a high-quality green tea which boasts a fine, fresh, “green” taste.
Dispensed temperature: approx. 150°F (65°C), brewing time: approx. 1.5 minutes
- **White Tea** is a green tea where only the young buds of the tea plant are used and processed very gently. White tea has a particularly mild taste.
Dispensed temperature: approx. 160°F (70°C), brewing time: approx. 2 minutes
- **Green Tea** gets its green color from the leaves of the tea plant. The tea leaves are either roasted or steamed depending on the region. Green tea can be infused multiple times.
Dispensed temperature: approx. 175°F (80°C), brewing time: approx. 2.5 minutes

- Place a cup under each of the main coffee dispenser spouts.
- Tap the ☐ symbol immediately before or after you start making a drink.

Dispensing starts and the ☐ symbol is highlighted in orange in the display. 2 portions of the desired drink will be dispensed.

Preparing a pot of coffee

You can make several cups of coffee one after the other automatically with the Coffee Pot function (maximum of 1 L).

The drinks menu is displayed.

Tip: Make sure that the bean and water containers have enough beans and water inside them before starting the Coffee Pot function.

- Place a sufficiently large container under the central spout.
- Select Coffee Pot.

Tip: You will find Coffee Pot at the end of the drinks menu.

- Select the number of cups you want (3 to 8).
- Follow the instructions on the display.

Each portion of coffee will be ground, brewed, and dispensed individually. You can follow the process on the display.

You can interrupt the dispensing process at any time.

Preparing beverages

- **Black Tea** gets its dark color and characteristic taste from the fermentation of tea leaves. Black tea can be enjoyed with a little lemon or milk.
Dispensed temperature:
approx. 210°F (97°C), brewing time:
approx. 3 minutes
- **Chai Latte** has its origins in traditional Ayurveda medicine as a black tea with typically Indian spices and milk. The milk mellows the spices and tops off the flavor experience.
Dispensed temperature:
approx. 210°F (97°C), brewing time:
approx. 3 minutes
- **Herbal Tea** is an aromatic infusion drink made up of dried leaves or fresh parts of plants.
Dispensed temperature:
approx. 210°F (97°C), brewing time:
approx. 8 minutes
- **Fruit Tea** is made from dried pieces of fruit and/or parts of plants, e.g., rose hip. The taste of the drink varies according to which plants are used and how they are blended. Lots of fruit teas are also flavored.
Dispensed temperature:
approx. 210°F (97°C), brewing time:
approx. 8 minutes

The preset dispensing temperature varies depending on the type of tea. The respective dispensing temperatures are the ones that Miele recommends for making the types of tea concerned.

Whether you use loose tea leaves, blended tea, or tea bags depends on your own personal preference.

The amount of tea required varies from one type of tea to another. Always follow the recommendations of the manufacturer on the packaging or of the

retailer. You can adjust the amount of water according to the type of tea and the size of the cup (see “Changing the portion size”).

Making tea

The drinks menu is displayed.

- Pour loose tea into a tea filter or similar.
- Place the tea filter or the tea bag in the tea cup.
- Place the tea cup under the central spout.
- Select the type of tea on the display.

Hot water will be dispensed into the cup.

If you have selected TeaTimer | Automatic, the TeaTimer for the brewing time will start automatically.

Alternatively, you can also start the TeaTimer function manually at this point.

After the brewing time has elapsed, an audible signal will sound and the ⏰ symbol will flash.

- Tap ⏰ to confirm that the brewing time has elapsed.

The TeaTimer has elapsed.

- Now remove the tea leaves or the tea bag.

Starting the TeaTimer manually

- Prepare a cup of tea.
- Tap TeaTimer.

The editor opens with a suggested brewing time.

- Change the brewing time if necessary.
- Confirm with *OK*.

After the brewing time has elapsed, an audible signal will sound and the ⏰ symbol will flash.

- Tap  to confirm that the brewing time has elapsed.

The TeaTimer has elapsed.

- Now remove the tea leaves or the tea bag.

Preparing a pot of tea

The Tea pot function allows you to make a large quantity of tea (maximum of 1 L). The type of tea selected determines the preset temperature.

The drinks menu is displayed.

Tip: Make sure that the water container has enough water inside it before you start making a pot of tea.

- Place a sufficiently large container under the central spout.
- Select the tea pot option you want.
- Select the number of cups you want (3 to 8).

You can interrupt the dispensing process at any time.

- Tap .

Dispensing warm or hot water

You can choose between the following options:

- Hot water at approx. 195°F (90°C)
- Warm water at approx. 150°F (65°C)

The drinks menu is displayed.

- Place a suitable container under the central spout.
- Choose between warm or hot water.

Dispensing will start.

Expert Mode

In Expert mode, you can allocate a bean type temporarily and change the portion size while the drink is being made. The setting will **not** be saved and will only apply to the current drink.

Switching Expert mode on and off

Expert mode is located in the pull-down menu at the top edge of the screen.

- Tap the top edge of the screen in the middle and drag down with your finger to open Expert Mode.

The schematic representation of the bean containers is displayed.

- Tap Expert Mode.

Expert mode is active when Expert Mode is highlighted in orange.

- To exit the pull-down menu, drag the menu window back up to the top or tap an area of the screen outside of the pull-down menu.

Expert mode: allocating bean containers

- Tap the top edge of the screen and open the Expert Mode pull-down menu.
- Now select the bean container containing the beans you want to use for the current drink.
- To close the menu window, drag it back up to the top.
- If necessary, switch to the drinks menu.
- Now start making the drink.

Expert mode: changing the portion size

The drinks menu is displayed.

If you select DoubleShot ☉ or 2 portions ☐, Expert mode cannot be used to change the portion size.

- Select a drink.

Dispensing will start. You can adjust the portion size while it is being dispensed, e.g., individually change the amount of hot milk, milk froth, and espresso for a latte macchiato.

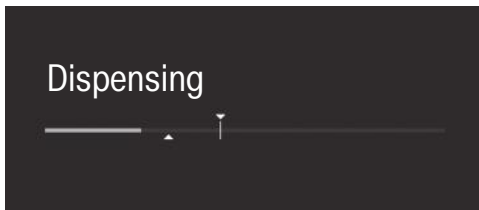

- Tap the bar and adjust the indicator (small triangle) as you wish.

The grinder setting determines the contact time between the ground coffee and the water, known as the extraction time. Only when the ideal grinder setting is selected can the machine dispense a perfect cup of coffee with a fine, hazelnut-brown crema.

Identifying the ideal grinder setting

There are various ways to tell whether the coffee grinder is set correctly.

The grinder setting is **too coarse** if the coffee or espresso is watery and tastes acidic. The crema is very pale.

The grinder setting is **too fine** if the coffee or espresso tastes too bitter and the crema is dark brown.

Adjusting the fineness of grind

If the grinder setting is adjusted by more than one level, the grinder may be damaged.

Only adjust the grinder one setting at a time.

Each time you adjust the setting, start making a new drink so that the beans are ground. Adjust the grinder setting one setting at a time again.

The slide control for adjusting the fineness is located on the top left behind the water container.

- Open the appliance door.
- Remove the water container.

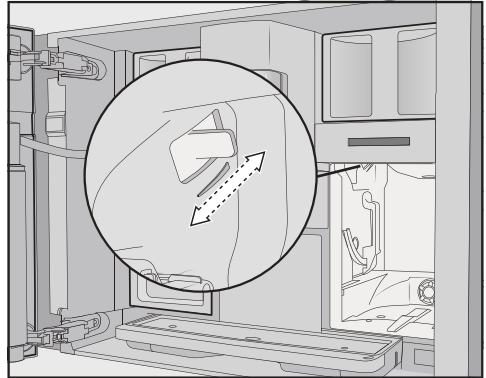

- Push the slide control **exactly 1 setting** forward (for finer grinding) or one setting backward (for coarser grinding).

The grinder setting you select will be used for all coffee drinks and types of beans.

- Put the water container back in place.
- Close the appliance door.
- Make one cup of coffee.

Adjust the grinder setting again, if required.

The grinder will naturally wear out slightly over time. Set the grinder to a finer setting if necessary.

Parameters

Type of beans

You can display which type of bean is currently being used for this coffee drink or change which bean container is allocated to it.

Amount of coffee

The coffee machine can grind and brew 7.5–12.5 g of coffee beans per cup. The greater the amount, the stronger the coffee.

The amount of coffee is **too low** if the espresso or coffee lacks body.

Increase the amount of coffee to brew more ground coffee.

The amount of coffee is **too high** if the espresso or coffee tastes bitter.

Decrease the amount of coffee to brew less ground coffee.

Pre-brewing ground coffee

When the pre-brewing function is turned on, the ground coffee is first moistened with a little hot water. The ground coffee swells a little.

Then the remaining water is forced through the moistened coffee at high pressure. If your coffee tastes too bland and you want to add some spice and richness, try the “Pre-brewing” function. Depending on the type of coffee used, pre-brewing can intensify the taste.

You can set a short or long duration for pre-brewing or turn the “Pre-brewing” function off completely.

Tip: It is particularly recommended to use the “Pre-brewing” function to make coffee.

Brewing temperature for coffee drinks

The brewing temperature must be adapted to the roast of the beans you are using. This is crucial whether you are making espresso or coffee.

Several types are sensitive to high brewing temperatures, resulting in an impaired taste. If your coffee tastes bitter, the brewing temperature you have selected might be too high.

Espresso is usually brewed at higher temperatures.

Dispensing temperature for tea drinks, warm water, and hot water

You can adjust the dispensing temperatures used for the individual tea drinks and for the warm and hot water by customizing the brewing temperature.

A temperature increment of approximately 35°F (2°C) makes a noticeable difference.

Portion size

You can adjust the amount of water for all coffee drinks, hot water, and types of tea.

The strength of the coffee is determined by the ratio between the amount of ground coffee and water. If the coffee is brewed with more water but with the same amount of ground coffee, the coffee will taste milder and thinner. If you reduce the amount of water, you will get a stronger and more powerful coffee.

If you significantly increase or decrease the portion size of a drink and therefore the amount of water for a coffee, you should adjust the amount of ground coffee accordingly.

For coffee drinks with milk you can also set the amount of milk or milk froth to suit your personal taste. You can also set the portion sizes for hot milk and milk froth.

The changed portion size is always saved in the current profile. The name of the current profile is shown in the top left of the display.

If the water container becomes empty while making a drink, the coffee machine will stop programming the portion size. The new portion size will **not** be saved.

Displaying and changing parameters

You can individually adjust the following parameters for each drink:

- Bean type
- Amount of coffee
- Brewing temperature
- Pre-brewing

You can adjust the brewing temperature for making tea and dispensing warm and hot water.

The drinks menu is displayed.

- Tap the name of the drink you want and keep your finger on it until the associated context menu appears.

- Select Parameters.

The Parameters menu is displayed.

- Select the parameter you want.

The current setting is displayed.

- Change the setting as required.

Changing the portion size

The drinks menu is displayed.

- Place the desired cup under the central spout.
- Tap the drink you want and keep your finger on it until the context menu opens.
- Tap Portion size.

The drink will now be made. *Save* will appear in the display as soon as the minimum dispensing amount is reached.

- When the cup is filled to the level you want, tap *Save*.

If the maximum amount is reached, preparation stops and the maximum possible amount is saved.

If you want to change the portion size for coffee drinks made with milk or hot water, the ingredients which make up the drink will be saved one after the other while the drink is being made.

The programmed mix of ingredients and the portion size will now be dispensed every time that particular drink is selected.

Parameters

Resetting drinks

You can reset portion sizes and parameters to their factory default settings for individual drinks or for all drinks.

The drinks menu is displayed.

- Tap the drink you want and keep your finger on it until the context menu opens.
- Select **Reset** and confirm with **Yes**.

The portion size and parameters are reset to their factory default settings. The allocated bean type remains stored.

Profiles

In addition to the Miele drinks menu (Miele profile), you can create individual profiles to cater for different tastes and preferences.

Within the profile, you can adjust the portion sizes and parameters individually for all drinks.

You can also delete any unwanted drinks from your profile. You can save a maximum of 9 drinks in a profile.

Creating a profile

The drinks menu is displayed.

- Tap Profiles.

The Profiles menu opens.

- Tap Create profile.

The editor will open in the display.

- Enter the name you want.
- Tap Save.

The profile is created. You can now create drinks (see “Profiles: creating and processing drinks”).

Processing a profile

You can rename, delete, or move profiles you have created yourself.

The drinks menu is displayed.

- Tap Profiles.

The Profiles menu opens.

- To do this, tap the profile name you want to edit and keep your finger on it until the context menu appears.
- Edit the entry as required.

Setting when the profile should change

The drinks menu is displayed.

- Tap Profiles.

The Profiles menu opens.

- To do this, tap the profile name you want to edit and keep your finger on it until the context menu appears.
- Select the option you want.

You can choose between the following options:

- **Manual:** The selected profile will remain active until you select another one.
- **After each use:** The machine will revert to the Miele profile whenever a drink is dispensed.

Creating a drink

You can create new drinks based on existing drinks.

The drinks menu is displayed.

- Tap Profiles.

The Profiles menu opens.

- Select the profile you want.

The name of the profile is shown in the top left of the display.

- Tap Create drink.

- Now select a drink.

- Change the portion size and drink parameters for this drink as required.

Preparation will begin and you can save the portions for each component as you wish.

- Enter a name for the new drink and tap Save.

The newly created drink will appear in the profile.

Profiles

Renaming, moving, or deleting drinks

Once you have created some drinks, you can edit these drinks in the context menu.

The desired profile with the newly created drinks will appear in the display.

- To do this, tap the drink name and keep your finger on it until the context menu appears.
- Edit the entry as required.

You can display frequently made drinks, drinks from profiles, and preferred maintenance programs on the MyMiele screen.

Tip: You can also set menu options that you have entered in MyMiele as your start screen (see “Settings – Start screen”).

The main menu is displayed.

- Tap MyMiele.

You can now configure MyMiele.

MyMiele: Adding an entry

- Tap Add entry.

You can now add entries from the following menus:

- Drinks
- Profiles
- Maintenance

- Select an entry.
- Confirm the message with *OK*.

A box containing the selected option will appear. This also shows which menu it comes from.

MyMiele: Deleting or moving an entry

Once you have created some entries, you can move or delete them via the context menu in the MyMiele screen.

- To do this, tap the entry you want and keep your finger on it until the context menu appears.
- Move or delete the entry as required.

Preparing MobileStart

 Danger of burning and scalding at the spouts.

If liquids or steam are dispensed while the machine is unsupervised, persons may burn themselves if they place body parts under the central spout or touch hot components.

Ensure that no one, especially children, can be harmed if the machine is operated without supervision.

Milk is **not** cooled in the milk flask or in a milk carton.

Milk may spoil if it is left in the milk flask or carton for an extended period without being cooled (depending on the type of milk).

In particular, do not leave cow's milk in the milk flask or carton for an extended period without cooling it. Please follow the manufacturer's instructions regarding the shelf life of the milk used.

With MobileStart  you can, for example, start making a drink via the Miele app.

- Make sure that the coffee machine is ready to use – for example, check that the water container and bean container are sufficiently filled.
- Place a sufficiently large, empty cup under the central spout.
You will only be able to use MobileStart if
 - Miele@home is set up for your coffee machine and
 - the Remote Control  and MobileStart functions have been switched on.

You can then make drinks via the app.

Switching MobileStart on and off

If you want to use MobileStart , the Remote Control function must be switched on.

The drinks menu is displayed.

- Touch the  sensor control.

The  sensor control lights up. You can now start making a drink via the app. Follow the prompts to do this.

While MobileStart is switched on, the time of day is shown on the display. If the coffee machine is being operated manually, it cannot be operated via the app. Operation on the appliance takes precedence. After 24 hours, the MobileStart function is switched off automatically.

You can personalize your coffee machine by adapting the factory default settings to suit your requirements.

Displaying and changing settings

The drinks menu is displayed.

- Tap the *Back* sensor button.
- Select Settings.
- Select the option you want to change.
- Change the setting.

If necessary, confirm your choice with *OK*.

Some settings which can be found in the Settings menu are described in separate sections of the operating instructions.

Language

You can select the language and, if applicable, your location for all display text.

Tip: If you select the wrong language by mistake, you can find the Language option again via the  symbol.

Time

Display (time display)

Select how you want the time of day to show in the display when the coffee machine is switched off:

- **On:** The time is always visible in the display.
- **Off:** The time is not visible in the display.
- **Night dimming:** To save energy, the time is displayed from 5:00 am to 11:00 pm only.

When the time of day display is switched on, the energy consumption of the coffee machine increases.

Clock type

The time of day can be displayed in **analog** (clock face) or **digital** (hours: minutes plus date) format when the coffee machine is switched off.

Clock format

- 24-hour display (24 h)
- 12-hour display (12 h (am/pm))

Setting

Set the hours and the minutes.

Tip: There is a shortcut for setting the time without having to access the Settings menu: simply tap the time of day on the top right of the display.

If the coffee machine has been connected to a Wi-Fi network and signed into the Miele app, the time will be synchronized based on the location setting in the Miele app.

Date

Set the date.

The date will only appear if the following setting is selected: Time | Clock type | Digital.

Start screen

You can choose which screen appears when the coffee machine is switched on. For instance, you can use MyMiele to display a personalized menu (see “MyMiele”).

The new start screen will appear when the coffee machine is next switched on.

Settings

The drinks menu is set as the start screen by default.

Timer

Appliance timer

The coffee machine has 3 timers:

- Turn on at
- Turn off at
- Off after

You can allocate the individual timer functions to different days of the week. For example, you can set different times for the weekend (Sat and Sun) and/or weekdays (Mon - Fri). Alternatively, you can select **Daily** to use the same timer settings every day.

Tip: If you are unable to set the timers because the screen is grayed out, tap **On** to enable timer adjustment.

To save the timer functions and activate the timer, select **Accept all**.

To deactivate the timer, select **Switch all off**.

Delete allows you to deactivate timers individually. In this case, the following will appear in the display: -- --.

On at (On at)

The coffee machine switches on at a particular time, e.g., in the morning for breakfast.

The coffee machine will **not** switch on at the required time if you have activated the system lock. The timer settings are deactivated.

Once the coffee machine has come on automatically **three times** at the set time without any drinks being dispensed, it will stop switching on automatically. This prevents the coffee

machine from switching itself on unnecessarily, for example, while you are on vacation. The programmed times will, however, remain in memory and will be reactivated after manually switching the machine on again.

If you have set the time to be displayed while the machine is switched off (Display | On or Night dimming) and the time is being displayed in digital format (Clock type | Digital), the  symbol and the desired switching-on time will appear in the display 23:59 hours beforehand.

Off at (Off at)

The coffee machine switches off at a particular time.

Off after (Off after)

The coffee machine switches off after a particular length of time if no sensor controls have been pressed.

By default, the coffee machine switches off after 20 minutes.

You can change this to another time between 20 minutes and 9 hours.

Extending the **Off after** time increases the energy consumption of the coffee machine.

If you deactivate the timer functions by selecting **Switch all off**, the coffee machine will switch off after the most recent time selected for **Off after**. You cannot deactivate this timer.

Maintenance timer

Use the Maintenance Timer to select any start time you like for the automatic maintenance programs (see “Automatic cleaning and descaling – Maintenance Timer”).

TeaTimer

You can use the TeaTimer function to start a kitchen timer when making tea. There is a preset brewing time for the type of tea selected. You can adjust the preset brewing time (up to a maximum of 14:59 minutes).

There are 2 TeaTimer functions available and they can be started independently of one another.

You can choose between the following options:

- **Automatic:** The TeaTimer starts automatically once the water has been dispensed.
- **Manual:** Once the water has been dispensed, you have the option of starting the TeaTimer.

The TeaTimer is shown together with the associated brewing time in the top right of the display.

While the brewing time is counting down, you can continue to use the coffee machine as normal. After the brewing time has elapsed, an audible signal will sound and the ⌚ symbol will flash.

Volume

You can set the volume of the buzzer and keypad tones in the bar chart.

Display

Brightness

The display brightness is adjusted via a bar with seven segments.

Color scheme

Choose between a light or dark color scheme for the display.

If the light color scheme is selected, the energy consumption will be higher.

QuickTouch

Use this setting to define whether the ☺ sensor button and proximity sensor should respond when the coffee machine is off and the time is being shown in the display (Time | Display | On or Night dimming).

When QuickTouch is switched on, the energy consumption will be higher.

Lighting

Use the segment bar to set the lighting intensity.

You can use the ☺ sensor control to switch the lighting on or off at any time, provided that the coffee machine is switched on.

If the coffee machine is switched off, you can still switch the lighting on or off whenever you like but you will need to select the following settings first:

- Time | Display | On or Night dimming (time of day is displayed)
- Display | QuickTouch | On

The brighter the lighting is set and the longer it is switched on, the higher the energy consumption of the coffee machine.

Settings

Info (display information)

In the Info menu option, you can display the number of drinks dispensed and the fill levels of the cartridges (provided that they have been inserted).

Fresh water

The machine is intended to be plumbed into the water supply. Fresh water is automatically taken into the water container when the plumbed water connection is on. If it is switched off, you must fill the water container manually.

Altitude

If the coffee machine is installed at high altitudes, the lower air pressure will cause the water to boil at a correspondingly lower temperature.

You can set the local altitude to ensure the ideal drink preparation temperatures.

Performance Mode

You can select the appropriate Performance mode for how you use your appliance:

- Eco mode
- Barista Mode
- Latte mode

There is also a mode for occasional, intensive use of the coffee machine: the

Eco Mode

In Eco Mode, the coffee machine consumes the least amount of energy. The system does not heat up until someone starts making a drink.

Eco Mode is set by default. Selecting a Performance mode other than Eco Mode increases the energy consumption of the coffee machine.

Barista Mode

This Performance mode has been optimized for unadulterated coffee enjoyment. Users can enjoy coffee-based drinks without any delay as the coffee machine remains heated to the brewing temperature.

Barista Mode consumes more energy than Eco Mode.

Latte Mode

This Performance mode has been optimized for preparing milk. In Latte Mode, milk-based drinks can be prepared within a much shorter space of time.

Latte Mode consumes more energy than Eco Mode and Barista Mode.

Party Mode

This Performance mode has been configured for the **occasional** intensive use of the coffee machine, e.g., for family get-togethers.

Before switching off the coffee machine, empty the drip tray and fill the water container so that any pending maintenance programs are able to run.

Clean the coffee machine thoroughly after intensive use, particularly the milk pipework. It may be necessary to descale the coffee machine manually and degrease the brew unit.

Please note the following information about Party mode:

- The general pipework is rinsed much less frequently or not at all. The milk pipework is not rinsed until around 1 hour after milk was last dispensed.
- Cleaning status messages or cleaning prompts are suppressed and delayed until the appliance is next switched on.
- The cup light remains permanently switched on at the maximum brightness level for as long as the coffee machine stays switched on.
- The Off at and Off after timers are deactivated.
- The coffee machine switches off 6 hours after the last sensor control was pressed. The next time the appliance is switched back on, Party mode is switched off and the most recently set Performance mode is switched back on.

Party mode consumes more energy than other Performance modes.

Water hardness

Program the coffee machine to the water hardness level of your area so that it functions correctly and does not get damaged.

Your local water authority will be able to tell you the hardness of the water in your area.

If you are using bottled drinking water, e.g., mineral water, select settings according to the calcium content. The calcium content is given on the label of the bottle in mg/l Ca²⁺ or ppm (mg Ca²⁺/l).

Do not use carbonated water.

The hardness level is set to 21.8 gpg (21°dH) by default.

Water hardness		Calcium content mg/l Ca ²⁺ or ppm (mg Ca ²⁺ /l)	Setting
°dH	gpg		
1	1	7	1
2	2	14	2
3	3	21	3
4	4	29	4
5	5	36	5
6	6	43	6
7	7	50	7
8	8	57	8
9	9	64	9
10	10	71	10
11	11	79	11
12	12	86	12
13	14	93	13
14	15	100	14
15	16	107	15
16	17	114	16
17	18	121	17
18	19	129	18
19	20	136	19
20	21	143	20
21	22	150	21
22	23	157	22
23	24	164	23
24	25	171	24
25	26	179	25
26	27	186	26
27	28	193	27
28	29	200	28
29	30	207	29

Settings

Water hardness		Calcium content mg/l Ca ²⁺ or ppm (mg Ca ²⁺ /l)	Setting
°dH	gpg		
30	31	214	30
31	32	221	31
32	33	229	32
33	34	236	33
34	35	243	34
35	36	250	35
36	37	257	36
37–45	38–47	258–321	37–45
46–60	48–62	322–429	46–60
61–70	63–73	430–500	61–70

Tip: If your water hardness is > 21.8 gpg (21°dH), we recommend using bottled drinking water instead (< 150 mg/l Ca²⁺). This will mean your coffee machine will need to be descaled less often and there will be less impact on the environment because less descaling agent will be used.

MotionReact

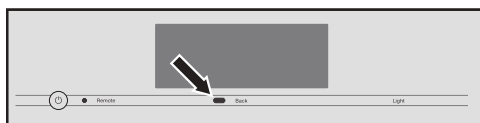

The movement sensor detects when you approach the touch display with your hand or body. You can activate the following functions individually:

- **Switch the light on:** You can decide whether the light should come on when the coffee machine is on or off.
- **Acknowledge buzzer:** Audible signal sounds are suppressed, e.g., in the event of the message Fill and replace the water container.

- **Switch the appliance on:** The start screen is displayed.

The movement sensor is deactivated by default.

If you want the movement sensor to respond even when the coffee machine is switched off, activate QuickTouch as well (Display | QuickTouch | On).

When the system lock is activated, the movement sensor functions are deactivated.

System lock

You can lock the coffee machine to prevent it from being used by unauthorized persons, such as children.

When the system lock is activated, the settings for the On at timer and the movement sensor are deactivated. The coffee machine will **not** switch on at the set time and/or will not respond to movement when someone approaches it.

Temporarily deactivating the system lock

- Tap the display for 6 seconds.

The system lock is reactivated when the coffee machine is next switched off.

Miele@home

The coffee machine is equipped with a Wi-Fi module and enabled for Miele@home.

Depending on whether you have connected the coffee machine to your network or not, the following options are displayed under Miele@home:

- **Set up:** This option only appears if the coffee machine has never been connected to a Wi-Fi network or if the network configuration has been reset.
- **Deactivate*/Activate*:** The settings for the Wi-Fi network are retained, but the network is switched on or off.
- **Connection status*:** Information about the Wi-Fi connection is displayed. The symbols indicate the strength of the connection.
- **Set up again*:** The settings for the current Wi-Fi network will be reset. The Wi-Fi connection will be set up again.
- **Reset*:** Networking is switched off and the settings for the current Wi-Fi network will be reset.

* This menu option appears if Miele@home has been set up and the coffee machine has – where applicable – been connected to a Wi-Fi network.

Tip: When the coffee machine is ready for operation, you can start networking it at any time by briefly touching the  sensor control or by scanning the QR code in these operating instructions (see “Performing Scan & Connect”).

Networking increases the energy consumption of the coffee machine, even if it is switched off.

The network configuration should be reset whenever the coffee machine is being disposed of or sold, or if a used coffee machine is being put into operation. This is the only way to ensure that all personal data has been removed and the previous owner will no longer be able to access the coffee machine.

Performing Scan & Connect

Initial commissioning has been carried out without Miele@home having been set up.

- Scan the QR code.

If you have installed the Miele app and have a user account, you will be taken directly to the networking steps.

If you have not yet installed the Miele app, you will be taken to the Apple App Store® or the Google Play Store™.

- Install the Miele app and set up a user account.
- Scan the QR code again.

The Miele app will guide you through the setup process.



Remote control

The Remote ControlRemote Control menu option appears if Miele@home has been set up and the coffee machine has been connected to a Wi-Fi network.

You can change the coffee machine settings, for example, in the Miele app when remote control is switched on. To start making a drink via the app, MobileStart also needs to be activated.

The remote control function is switched on by default.

SuperVision

SuperVision allows you to monitor other domestic appliances in the Miele@home system.

Settings

The SuperVision option appears when the coffee machine is connected to a Wi-Fi network.

You can switch SuperVision on or off for the signed-in domestic appliances. You can also switch the audible signal on or off for the listed domestic appliances.

SuperVision display

When SuperVision is on (SuperVision | On), the  symbol appears in the display.

When the SuperVision display is switched on, the energy consumption of the coffee machine increases.

Standby display

SuperVision is also available in Standby mode if the time display function is switched on (Settings | Time | Display | On or Night dimming).

Appliance list

All domestic appliances signed in to the Miele@home system are listed. If you switch off SuperVision for a particular domestic appliance, any faults that occur in relation to this appliance will still be displayed.

The Searching for appliances function increases the energy consumption of the coffee machine.

RemoteUpdate

The RemoteUpdate function allows the software on your coffee machine to be updated. If an update is available for your coffee machine, it will automatically download it. Updates will not be installed automatically. They must be initiated manually.

If you do not install an update, you can continue to use your coffee machine in the usual way. However, Miele recommends installing updates.

The RemoteUpdate menu option is only displayed and can only be selected if the requirements for using Miele@home have been met.

The RemoteUpdate function is activated by default. Available updates will be downloaded automatically but will only be installed if you initiate installation manually.

Deactivate RemoteUpdate if you do not want any updates to be downloaded automatically.

Running a RemoteUpdate

Information about the content and scope of an update is provided in the Miele app.

A message will appear in your coffee machine display if an update is ready for installation.

You can install the update immediately or postpone this until later. You will be reminded about the update the next time you switch the coffee machine on.

Deactivate RemoteUpdate if you do not want to install the update.

The update may take several minutes.

Keep in mind the following with respect to RemoteUpdates:

- You will only receive a message when a RemoteUpdate is available.
- Once a RemoteUpdate has been installed, it cannot be undone.

- Do not switch the coffee machine off during the update. Otherwise, the update will be aborted and will not be installed.
- Some software updates can only be carried out by Miele Service.

Software version

The “Software version” menu option is intended for Miele Technical Service. You do not need this information for domestic use.

Legal information

This menu option contains details of the open source licenses used.

Showroom program (Demo mode)

Do not activate this setting for domestic use.

The Showroom Program | Demo Mode function enables the coffee machine to be demonstrated in shops or showrooms. In this mode, the machine lights up but no drinks can be prepared and no maintenance programs can be run.

You can activate demo mode without commissioning the appliance for the first time. Switch the coffee machine on and off again. Press the ↵ / *Back* button for 5 seconds straight away. Demo mode is activated.

Factory default settings

You can reset the coffee machine to its factory default settings.

MyMiele can be reset separately.

The following will **not** be reset:

- The number of drinks and the machine status (No. of portions until machine needs descaling, ... degreasing the brew unit)
- Language
- Time and date
- Profiles and their associated drinks (the allocation of bean types to drinks is reset)
- Miele@home

The Maintenance timer is reset to 2 am.

Cleaning and care

 Risk to health due to inadequate cleaning.

Heat and moisture inside the coffee machine can cause coffee residues to become moldy and/or milk residues to go off and pose a risk to health.

Carefully clean the coffee machine regularly.

Overview of cleaning intervals

Recommended frequency	What do I have to clean/maintain?
Daily (at the end of the day)	Milk flask and lid
	Milk valve
	Water container
	Drip tray cover
	Drip tray and grounds container
Once a week (more often if heavily soiled)	Central spout
	Cup rim sensor
	Interior
	Brew unit
	Drip tray
	Appliance front
Once a month	Bean container
	Remove and clean the milk valve
Once a year (more often if required)	Grease the brew unit (with silicone grease)
As and when required/after prompt appears in display	Clean the milk pipework (with 2 cleaning sticks)
	Degrease the brew unit (with 1 cleaning tablet)
	Descale the appliance (with 2 descaling tablets)

Clean by hand or in dishwasher

The brew unit is **not** dishwasher safe. Only clean the brew unit by hand with warm water. **Do not use any cleaning agents.**

The following components must be cleaned **by hand only**:

- Central spout stainless steel cover
- Brew unit
- Bean containers and lids

 Risk of damage as a result of excessively high dishwasher temperatures.

Components may be ruined (e.g., may become warped) if washed in a dishwasher at temperatures higher than 130°F (55°C).

For dishwasher-safe components, always select dishwasher programs with a maximum temperature of 130°F (55°C).

Contact with natural dyes, such as those found in carrots, tomatoes, and ketchup, may discolor the plastic parts in the dishwasher. This discoloration does not affect the stability of the parts.

The following parts are **dishwasher-safe**:

- Drip tray, lid, and grounds container
- Drip tray cover
- Central spout (without stainless steel cover)
- Milk flask with lid
- Cup sensor

- Maintenance container
- Water container

 Danger of burning and scalding on hot components or by hot liquids. Components can become very hot during operation. Touching hot components can cause burning. The liquids and steam dispensed are very hot and can cause scalding.

Keep away from the area underneath the dispensers when hot liquids and steam are being dispensed.

Always allow the coffee machine to cool down before cleaning it.

Please be aware that water in the drip tray can also be very hot.

 Risk of damage due to moisture ingress.

The steam from a steam cleaning appliance could reach electrical components and cause a short circuit.

Do not use a steam cleaner to clean the coffee machine.

It is important to clean the appliance regularly. Milk residues can go off and can block the milk pipe.

Cleaning and care

Unsuitable cleaning agents

Contact with unsuitable cleaning agents can alter or discolor the external surfaces. All surfaces are susceptible to scratching. Scratches on glass can lead to breakage in some circumstances.

Remove any residual cleaning agent immediately. Make sure you remove any spillages or splashes of descaling agent immediately.

To avoid damaging the surfaces of your appliance, do not use the following cleaning agents:

- cleaning agents containing soda, ammonia, acids, or chlorides
- solvent-based cleaning agents
- disinfectant cleaning agents and hand sanitizer
- cleaning agents containing descaling agents (unsuitable for cleaning the front of the appliance)
- stainless steel cleaners
- dishwasher cleaners (unsuitable for cleaning the front of the appliance)
- glass cleaners
- cleaning agents for glass-ceramic cooktops
- oven cleaners
- steam oven cleaning agents (DGClean)
- abrasive cleaning agents, such as scouring powder, scouring cleansers, or pumice stones
- hard abrasive brushes or sponges, such as pot scourers or sponges which have been previously used with abrasive cleaning agents
- eraser sponges

- sharp metal scrapers
- steel wool or stainless steel sponges
- sunscreen

Opening the appliance door

Risk of damage when opening the door if the central spout is too high or too low.

If the central spout is too high or too low, the door cannot be opened. If you try to open the door, the central spout can be damaged.

Make sure that the central spout is in the top or middle position before you open the door.

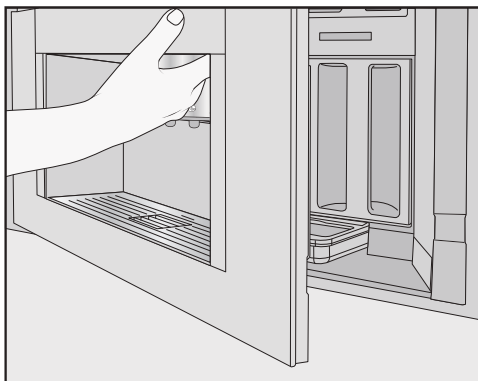

- Open the appliance door.

Cleaning the drip tray and grounds container

 Danger of burning and scalding on hot components or by hot liquids. Components can become very hot during operation. Touching hot components can cause burning. The liquids and steam dispensed are very hot and can cause scalding. If the pipework has just been rinsed, wait a while before removing the drip tray from the coffee machine. Please be aware that water in the drip tray can also be very hot. Do not touch hot components.

Clean the drip tray and grounds container **every day** to avoid unpleasant smells and mold fungi.

A prompt will appear in the coffee machine display when the drip tray and/or the grounds container is full and needs to be emptied. Empty the drip tray **and** the grounds container. It is not necessary to take the lid off the drip tray in order to empty it.

- Open the appliance door.

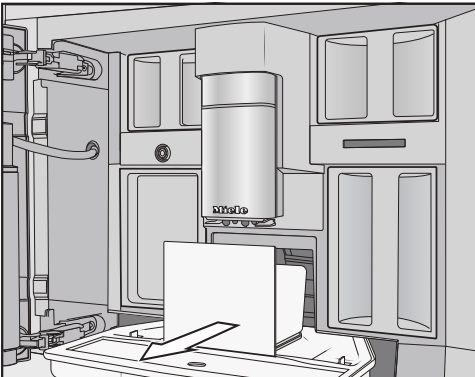

- Remove the drip tray and grounds container from the machine.

- Empty the grounds container after removing it from the drip tray.

The grounds container may contain a small amount of water from rinsing as well as the leftover coffee grounds.

Taking the drip tray apart

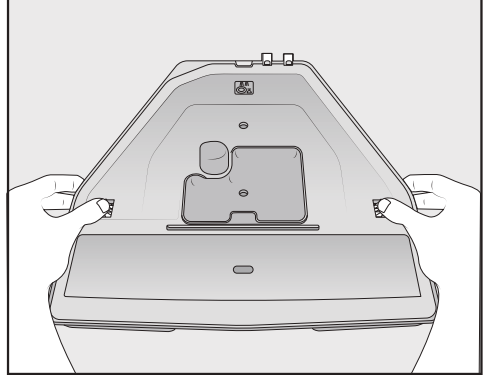

The orange clips are not removable.

- Take the lid off the drip tray as follows: press the orange clips outward on both sides to release the lid.
- Remove the lid.
- Clean the drip tray, lid, and grounds container by hand using warm water and a little liquid dish soap.
- Dry all parts.

Tip: To give the drip tray, lid, and grounds container an extra thorough clean, clean them in the dishwasher from time to time. If the drip tray is heavily soiled, clean it with a brush before placing it in the dishwasher.

- Clean the drip tray recess inside of the coffee machine.

Cleaning and care

Cleaning the contacts on the drip tray

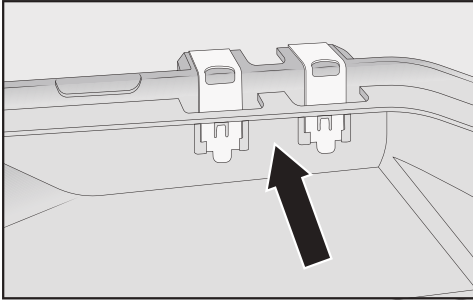

- Clean the contacts (metal discs) and the space between them carefully, e.g., using a brush.
- Dry all parts thoroughly.

The contacts will not be able to detect that the drip tray is full if they are damp or dirty. Check the contacts and the area around them once a week.

Reassembling the drip tray

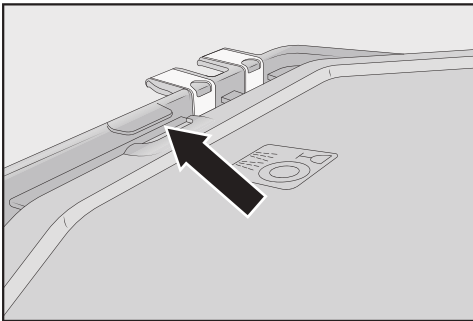

- Attach the drip tray lid as follows: slide the lid under the lug next to the contacts and apply pressure to the lid until the catches at the sides audibly click into place.

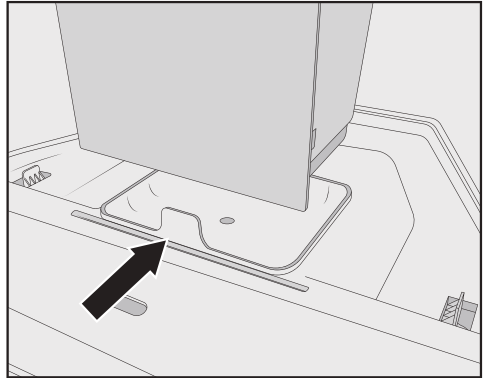

- Place the grounds container on the lid.
- Push the drip tray and grounds container back into the coffee machine.
- Close the appliance door.

Cleaning the drip tray cover

Clean the drip tray cover on a daily basis.

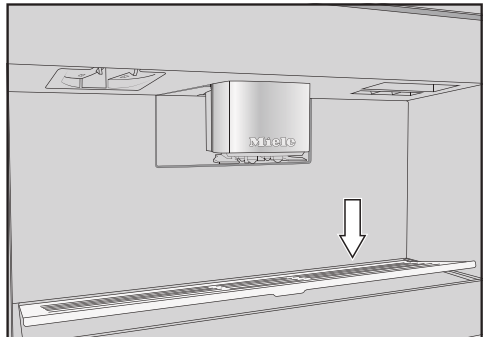

- Remove the drip tray cover as follows: apply pressure to the rear edge so that the cover tips forward and you can remove it easily.
- Clean the drip tray cover by hand using a mild solution of warm water and liquid dish soap.
- Dry the drip tray cover.
- Replace the drip tray cover.

Tip: To give the drip tray cover an extra thorough clean, clean it in the dishwasher from time to time.

Cleaning the water container

Clean the water container every day.

- Open the appliance door.
- Remove the water container.
- Clean the water container every day with a mild solution of warm water and liquid dish soap.
- Rinse the water container thoroughly with clean water to remove any remaining liquid dish soap.
- Dry the outside of the water container.

Tip: To give the water container an extra thorough clean, clean it in the dishwasher from time to time.

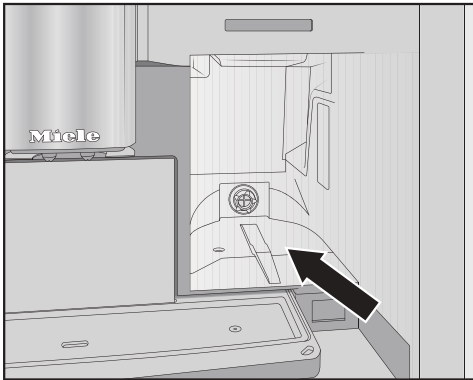

- Clean and dry the surface that the water container sits on.
- Push the water container all the way into the coffee machine until you feel a resistance.
- Close the appliance door.

Cleaning the central spout

Clean the central spout's stainless steel cover by hand only using a mild solution of warm water and liquid dish soap.

Clean all parts of the central spout at least once a week.

Removing the central spout

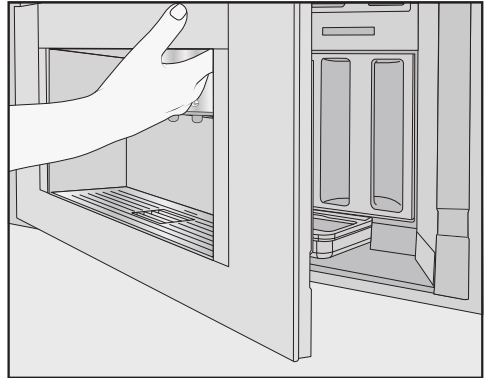

- Open the appliance door.

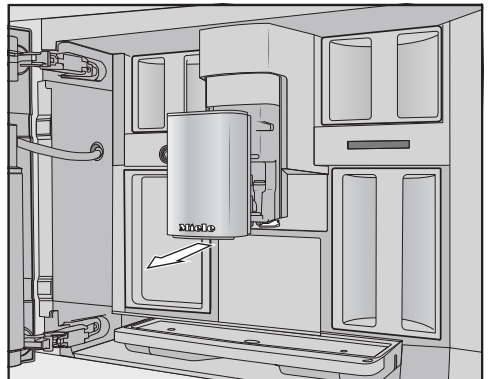

- Pull the central spout's stainless steel cover forward to remove it.
- Clean the central spout's stainless steel cover.

Cleaning and care

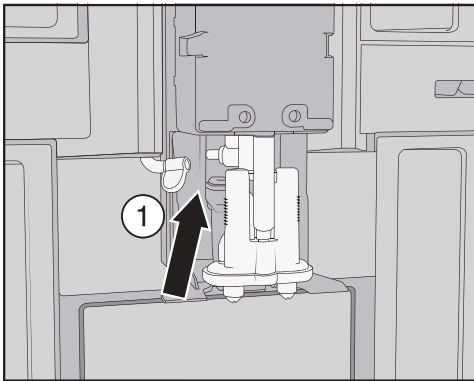

- Detach the milk pipework from the dispensing unit as follows: pull the pull tab ① to the left.

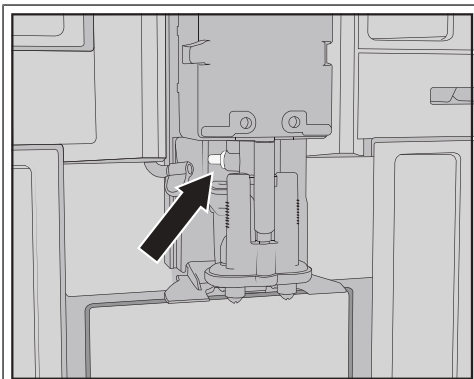

Do **not** remove the milk pipework connecting piece.

If necessary, clean the connecting piece with the cleaning brush.

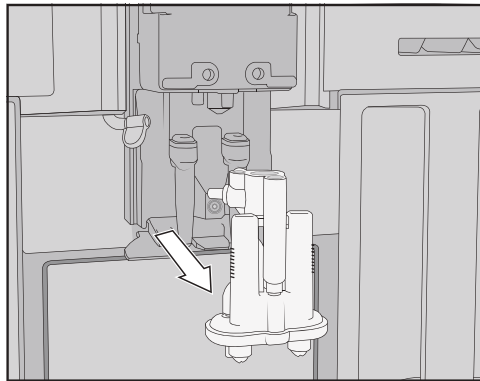

- Grip the dispensing unit by the sides and pull it down to remove it.

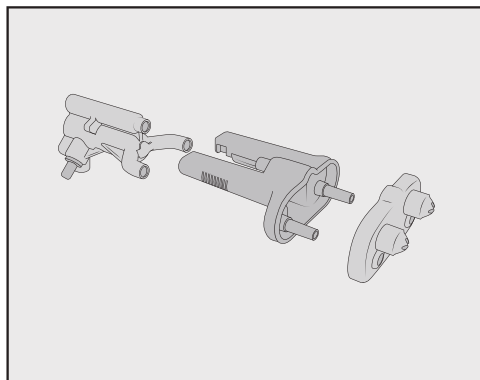

- Take the dispensing unit apart, separating it into 3 components: the Y-piece, the spouts, and the holder.

Cleaning the central spout

Clean the central spout's stainless steel cover by hand only using a mild solution of warm water and liquid dish soap.

- Clean all parts thoroughly by hand.

Tip: With the exception of the stainless steel cover, all parts of the central spout should be cleaned in the dishwasher from time to time to give them a thorough clean. This will remove coffee deposits and milk residues effectively.



- Clean the area around the central spout with a damp cloth.

Inserting the central spout

The dispensing unit is easier to reassemble if the individual parts are dampened with water beforehand.

Make sure that all parts are tightly connected to one another.

- Reassemble the dispensing unit.
- Press down firmly so that the spouts become securely connected to the holder.

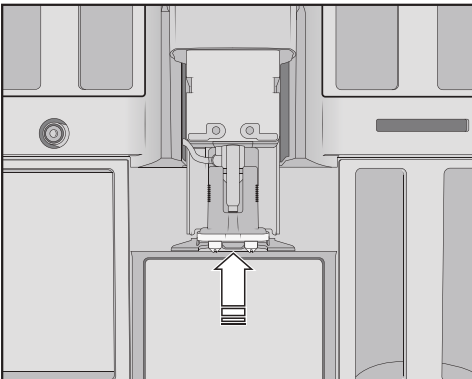

- Slide the dispensing unit into the coffee machine.
- Connect the milk pipework.
- Reinstall the stainless steel cover.

- Close the appliance door.
Fit cover to main dispenser appears in the display.
- Confirm with *OK*.

Cleaning the cup rim sensor

Clean the cup rim sensor at least once a week and more often if heavily soiled.

The cup rim sensor is located under the central spout.

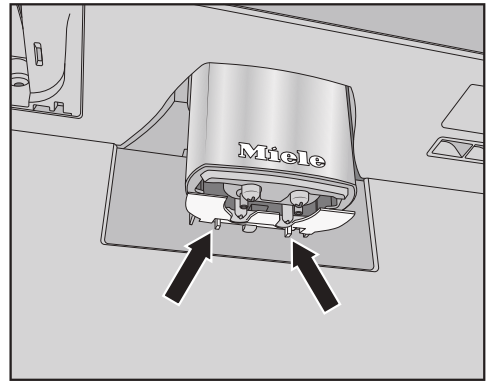

- Press the two catches together (see arrows).

The cup rim sensor is released.

- Clean the cup rim sensor by hand with a mild solution of warm water and liquid dish soap.

Tip: To give the cup rim sensor an extra thorough clean, clean it in the dishwasher from time to time.

- To reinstall the cup rim sensor, press it into the holder on the central spout from below.

Cleaning the milk flask with lid

The milk flask should be taken apart and cleaned every day after use.

Cleaning and care

Both the lid and the glass flask can be cleaned in the dishwasher, or by hand using a mild solution of warm water and liquid dish soap.

- Remove and empty the milk flask.

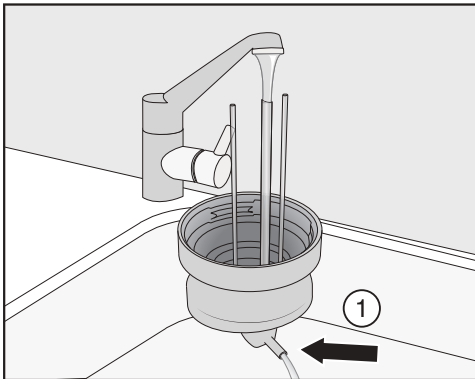

- Rinse the milk pipework in the lid under running water and then place the milk flask lid in the dishwasher.
- If no water runs out of the connecting piece ①, clean it with the cleaning brush.
- Clean the glass flask.
- Dry all parts and especially the threads on the lid and on the glass with a clean cloth.
- Reassemble the milk flask.

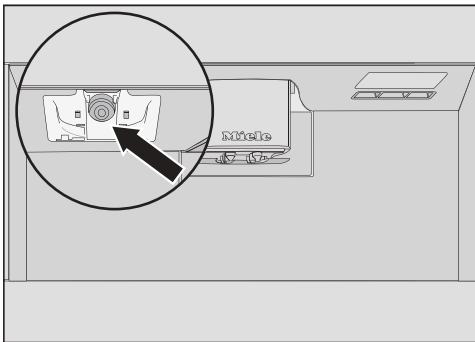

- Clean the milk flask holder on the coffee machine with a damp cloth.

Cleaning the milk valve (daily)

The milk valve seal can be damaged by objects with sharp edges or similar.

Do not use any sharp-edged objects, e.g., knives, to clean the milk valve.

Clean the milk valve every day. If allowed to dry, milk residues can become encrusted on the stainless steel bolt. These crusty deposits are difficult to remove. Therefore, it is important to carry out regular cleaning after preparing milk.

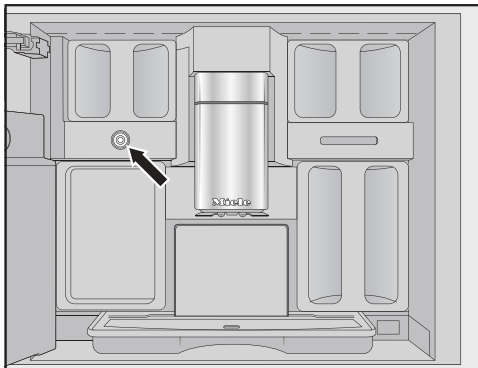

The milk valve is located under the bean container on the left-hand side.

- Open the appliance door.
- Clean the milk valve with a damp cloth/microfiber cloth.
- Close the appliance door.

Cleaning the milk valve (once a month)

Only remove the milk valve when the coffee machine is switched off. Do **not** switch on the coffee machine while the milk valve is removed.

Remove and clean the milk valve at least once a month. If the following issues occur during milk preparation, the milk valve may be blocked: only hot milk is dispensed instead of milk froth, the milk sprays out. Clean the milk valve more often if necessary.

Removing the milk valve

Only remove the milk valve when the coffee machine is switched off. Do **not** switch on the coffee machine while the milk valve is removed.

- Switch the coffee machine off.
- Open the appliance door.
- Remove the bean container and maintenance container on the left-hand side.
- Remove the central spout's stainless steel cover.



- Remove the milk valve cover. Press on the recessed grip to unlock the cover. On the top right-hand side of the cover, you will find a pin for swiveling the cover out.

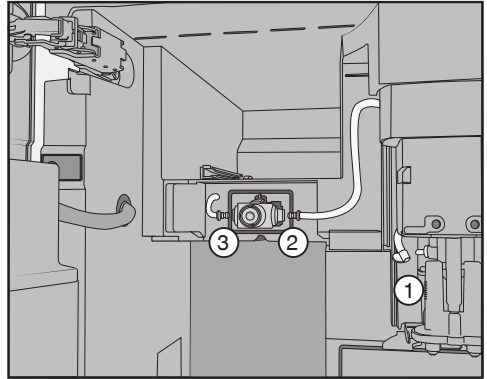

- Detach the milk pipework from the dispensing unit on the central spout ① and from the milk valve silicone seal (② and ③).
- Remove the milk pipework ① connecting the milk valve to the central spout.
- Disconnect the angular molded hose from the round hose.
- Rinse the hoses thoroughly under running water.

Do **not** remove the connecting pieces from the hoses.

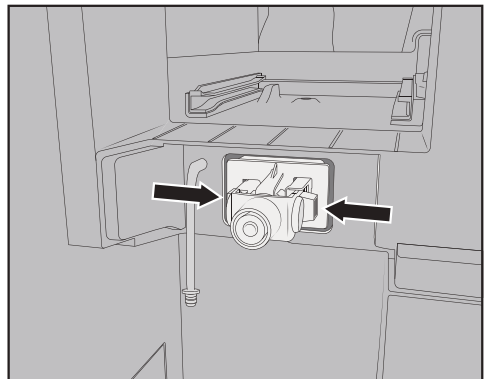

- Press the catches on the left and right-hand sides of the milk valve holder and pull the holder forward to remove it.

Cleaning and care

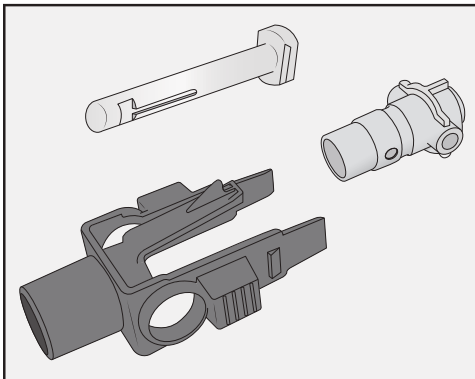

- Take the holder and silicone seal apart.

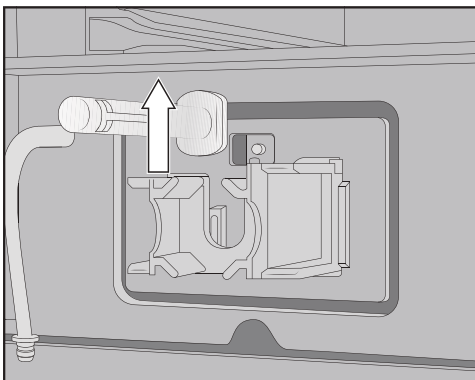

- Pull the stainless steel bolt upward and out.

Cleaning the milk valve

The milk valve cover is not dishwasher-safe.

The milk valve cover may be damaged if cleaned in the dishwasher.

The milk valve cover should only be cleaned **by hand**.

Do **not** switch on the coffee machine while the milk valve is removed.

- Clean all parts of the milk valve by hand.

Tip: With the exception of the cover, all parts of the milk valve should be cleaned in the dishwasher from time to time to give them a thorough clean. If there are any dry milk residues on the front, soak the stainless steel bolt in a mild solution of warm water and liquid dish soap.

Inserting the milk valve

Do **not** switch on the coffee machine while the milk valve is removed.

- Insert the stainless steel bolt from above.
- Insert the silicone seal into the milk valve holder.

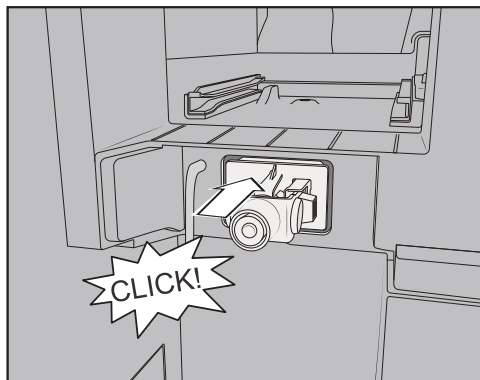

- Insert the holder and silicone seal until they audibly click into place.

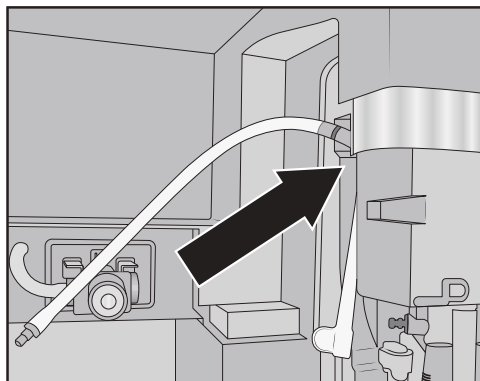

- Connect together the angular molded hose and longer milk pipework. Start by attaching the top of the molded hose to the central spout. The black connecting piece should be pointing to the rear.
- Then, connect the bottom end of the molded hose to the dispensing unit.
- Insert the milk pipework into the milk valve on the left and right-hand sides. Push the connecting pieces into the silicone seal as far as they will go.
- Check that the milk pipework is snug against the housing and that the cover can be easily attached.
- Attach the milk valve cover as follows: insert the pin in the top right-hand corner and swivel the cover backward until a proper fit is achieved.
- Push the left-hand bean container and maintenance container back into the coffee machine.
- Attach the central spout's stainless steel cover.
- Close the appliance door.

You can now switch the coffee machine back on.

Cleaning the bean containers

 Risk of damage from incorrect use and cleaning. Immersing the bean containers in liquids can result in malfunctions. If they are taken apart, bits may break off or the mechanism may no longer work properly once they are reassembled. Do not disassemble the bean containers. Do not immerse the bean containers in liquids, e.g., soapy water.

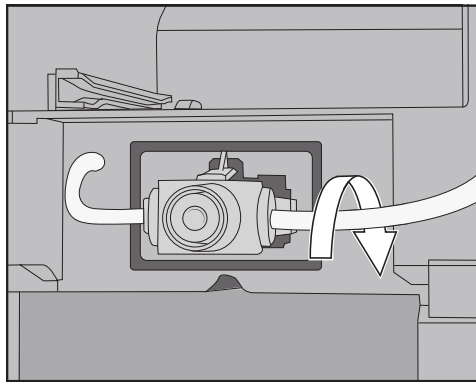

Tip: If necessary, screw the milk pipework backward at the connecting piece on the right-hand side.

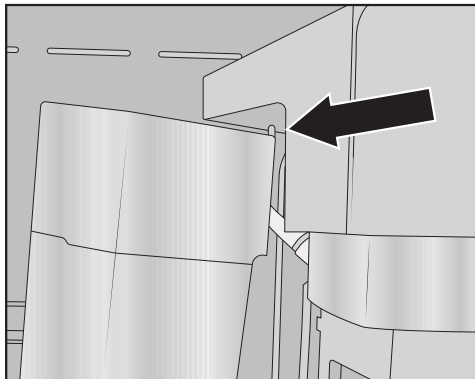

Coffee beans contain oils which can deposit on the walls of the bean containers and hinder the flow of the beans. Therefore, clean the bean containers at least once a month with a soft cloth.

If required, you can clean the lids of the bean containers **by hand** with a mild solution of warm water and liquid dish soap. Dry the lids thoroughly before replacing them on the bean containers.

- Open the appliance door.
- Pull the left and right-hand bean containers out of the coffee machine.

Cleaning and care

- Clean the bean container wells inside the machine.

Tip: Use a vacuum cleaner to remove any coffee residues from the interior.

- Remove the lids and empty the bean containers.

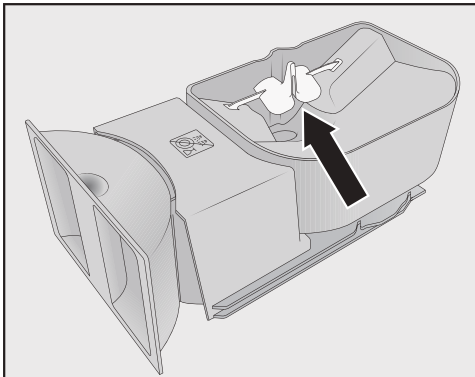

Do not remove the components for improving the flow of the beans (see arrow).

- Clean the bean containers and lids **by hand** using a slightly damp cloth.
- Dry all parts carefully before filling the bean containers with roasted coffee beans again.
- Replace the lids.
- Push the bean containers back into the coffee machine.
- Close the appliance door.

Cleaning the brew unit and interior by hand

The moving parts of the brew unit are lubricated. Cleaning agents will damage the brew unit.

Only clean the brew unit by hand with warm water. **Do not use any cleaning agents.**

Remove and rinse out the brew unit **once a week**. Also clean the area below the brew unit once a week. Depending on whether a cleaning cartridge is inserted, the display shows Remove brew unit, rinse and clean interior after 100 or 200 portions.

Removing the brew unit

It might not be possible to re-insert the brew unit if you have removed it and changed the position of the handle.

Once you have removed the brew unit, **do not** change the position of the handle.

- Open the appliance door.
- Remove the water container.

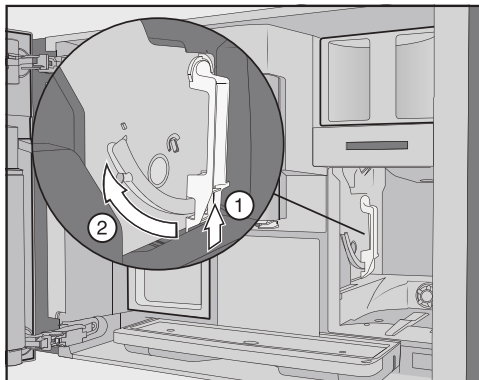

- Press the button under the handle of the brew unit ① and, while doing so, turn the handle forward ②.

Cleaning and care

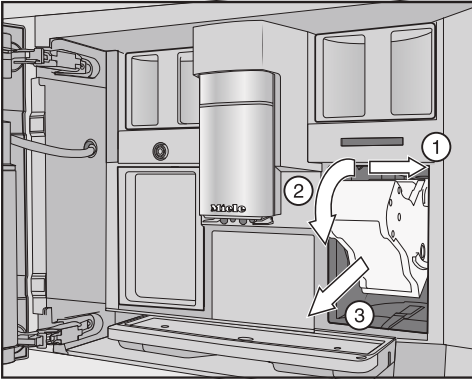

- Pull the brew unit to the side ① first and then pull out to the front ③. Tilt the brew unit forward ②.

If you cannot remove the brew unit or can only do so with difficulty, the brew unit drive is not in the correct position.

Cleaning the brew unit

The moving parts of the brew unit are lubricated. Cleaning agents will damage the brew unit.

Only clean the brew unit by hand with warm water. **Do not use any cleaning agents.**

- Clean the brew unit **by hand under warm running water** without using cleaning agent.

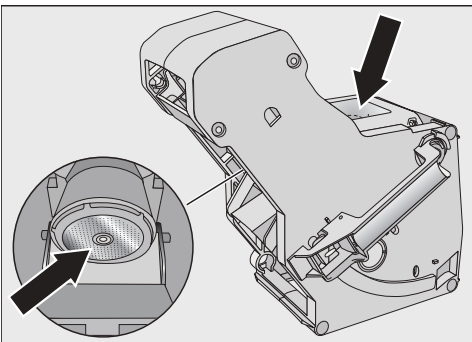

- Wipe any remaining coffee off the two filters. One filter is located in the funnel. The other filter can be found to the left of the funnel.
- Dry the funnel to prevent ground coffee sticking to it the next time a coffee is made.

Cleaning the interior of the appliance

- Use your vacuum cleaner to remove dry coffee grounds.

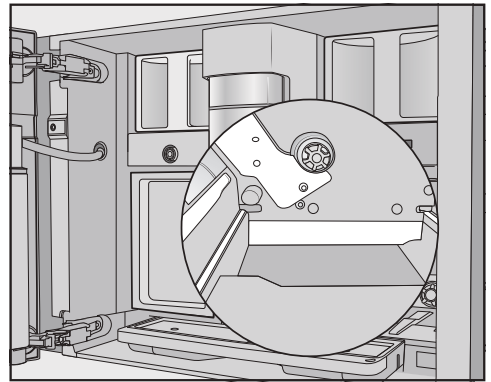

- Clean the niche of the brew unit with a damp, clean cloth. Clean the areas marked in white in the illustration, e.g., around the drive shaft, especially well.

Inserting the brew unit

- To insert, follow the instructions for removal in reverse order: push the brew unit back into the coffee machine. Tilt the brew unit forward a little when doing this.

If you cannot re-insert the brew unit, the brew unit drive is not in the correct position.

Cleaning and care

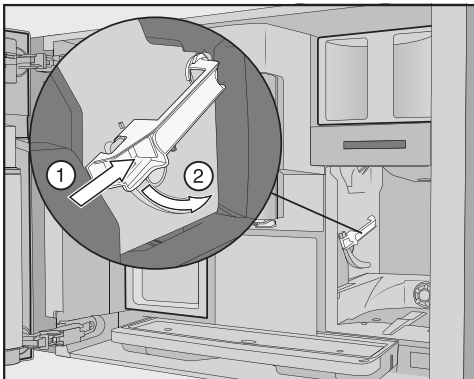

- Press the button under the handle of the brew unit ① and, while doing so, turn the handle backward ②.

Tip: If you are unable to turn the brew unit handle, apply firm pressure to the sides of the brew unit.

- Push the water container into the coffee machine.

The process of removing and inserting the brew unit causes ground coffee to drop into the drip tray.

- Remove the drip tray and clean the lid.
- Push the drip tray back into the coffee machine.
- Close the appliance door.

Cleaning the interior, inside of the appliance door, and drip tray

Clean the interior and appliance front as part of the normal cleaning process. For instance, if you remove the water container, use this as an opportunity to clean the area under the water container at the same time.

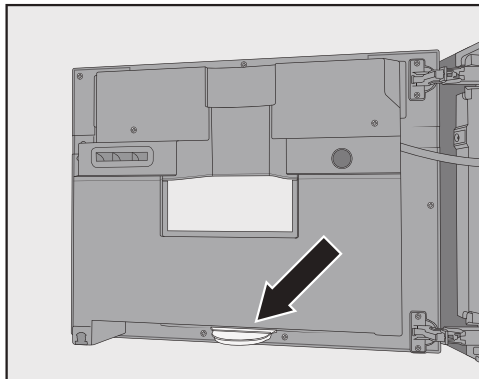

The drip tray is located at the bottom on the inside of the appliance door. Clean the drip tray regularly.

- Open the appliance door.
- Clean the drip tray.
- Remove the following parts from the interior:
 - Water container
 - Drip tray
 - Maintenance container
 - Brew unit
 - Bean container

Tip: Use your vacuum cleaner to remove dry ground coffee residues.

- Clean the interior and the inside of the appliance door by hand with a clean and slightly moist cloth/microfiber cloth.
- Wipe the interior and appliance door dry using a soft cloth.
- Reinsert all parts.
- Close the appliance door.

Cleaning the appliance front

If soiling is not removed promptly, it could cause the surface to alter or discolor.

Remove any soiling on the appliance front straight away.

Make sure that water cannot get behind the display.

Clean the appliance front after manual descaling. If possible, wipe up any spillages of descaling agent immediately.

Tip: Before cleaning the control panel, open the appliance door. This will prevent accidental operation.

- Clean the appliance front with a clean and slightly damp cloth/microfiber cloth.
- After cleaning, wipe the surfaces dry using a soft cloth.

Tip: You can also use a Miele Microfiber Cloth to clean the front.

Maintenance programs

The coffee machine has the following maintenance programs:

- Rinsing the appliance
- Rinsing the milk pipework
- Cleaning the milk pipework*
- Degreasing the brew unit*
- Descaling the machine*

* If you have not inserted a cleaning cartridge and automatic cleaning has been switched off, you will need to carry out this maintenance program manually.

Please also note that the coffee machine pipework may also have to be descaled manually at regular intervals even if a descaling cartridge has been inserted and automatic descaling is

switched on, depending on how you use your machine and the hardness of the water used.

Opening the Maintenance menu

The drinks menu is displayed.

- Touch the ↶ sensor control.
- Select Maintenance.

You can now start the desired maintenance program.

Rinsing the machine

If you have made a coffee drink, the coffee machine will rinse the coffee pipework automatically before switching off. You can also start the Rinse the Appliance function manually.

Rinsing the milk pipework

If you have made a drink with milk, the coffee machine will rinse the milk pipework automatically after a few minutes. You can also start the Rinse the milk pipework function manually.

Clean the milk pipework

You can run the maintenance program with the Miele cleaning cartridge or with the cleaning agent for milk pipework (small sticks of powder cleaning agent). The maintenance program lasts for approx. 20 minutes.

If you have switched on automatic cleaning and inserted a ready-to-use cleaning cartridge, the Clean the milk pipework maintenance program will run using the cleaning cartridge.

Cleaning and care

Cleaning the milk pipework with the cleaning cartridge

In addition to using the automatic cleaning function, you can also start the maintenance program manually, e.g., to clean the milk pipework after a period of intensive use.

The Maintenance menu is displayed.

- Tap Clean the milk pipework.
- Follow the instructions on the display.

Cleaning the milk pipework with the cleaning agent for milk pipework (sticks)

If automatic cleaning is switched off, the milk pipework must be cleaned after at least 15 days. Messages appear in the display to prompt you to clean.



For optimum cleaning results, it is recommended to use the Miele Cleaning Agent for milk pipework. The powder cleaning agent for milk pipework has been specially developed for use with Miele Coffee Machines and prevents subsequent damage.

For each cleaning process, you will need 2 sticks of the cleaning agent for milk pipework.

You can order the cleaning agent for milk pipework from the Miele online shop, from Miele Customer Service, or from your Miele dealer.

Clean the milk pipework will appear in the display.

- Confirm the message with *OK*.
- Follow the instructions on the display.

When Fill water container with lukewarm water and cleaning agent up to the  symbol and insert  appears in the display, proceed as follows.

- Open 2 sticks of the cleaning agent for milk pipework and empty the contents into the water container.

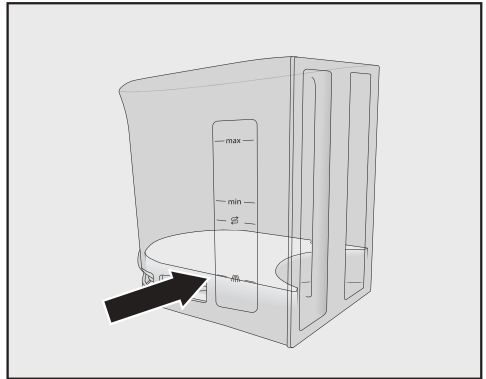

- Fill the water container to the  mark with lukewarm water and stir the solution.

Follow the instructions for the mixing ratio carefully. Do not fill the water container with too little water. Otherwise, cleaning will be incomplete.

- Reinsert the water container.
- Close the appliance door.
- Follow the instructions on the display.
- If prompted to do so in the display, rinse the water container thoroughly with clean water. Make sure that **no** cleaning agent is left in the water container. Fill the water container with fresh drinking water.

The cleaning process is finished when Program finished appears in the display.

Degreasing the brew unit

The brew unit must be degreased regularly in order to ensure aromatic coffee and trouble-free operation of the coffee machine. Depending on the

natural oil content of the type of beans used, the brew unit can become blocked quite quickly.

You can run the maintenance program with the Miele cleaning cartridge or with cleaning tablets for degreasing the brew unit. The maintenance program lasts for approx. 10 minutes.

If you have switched on automatic cleaning and inserted a ready-to-use cleaning cartridge, the Degrease the brew unit maintenance program will run using the cleaning cartridge.

If you have not inserted a Miele cleaning cartridge, Degrease the brew unit. will appear in the display after 200 portions.

■ Confirm with *OK*.

This message will keep being displayed until the brew unit has been degreased.

Starting Degrease brew unit

The Maintenance menu is displayed.

■ Tap Degrease the brew unit.

The maintenance program will then start.

■ Follow the instructions on the display.

Remove the water container and the brew unit. Rinse the brew unit by hand and clean the interior of the machine appears in the display.

Removing the brew unit

It might not be possible to re-insert the brew unit if you have removed it and changed the position of the handle.

Once you have removed the brew unit, **do not** change the position of the handle.

■ Open the appliance door.

■ Remove the water container.

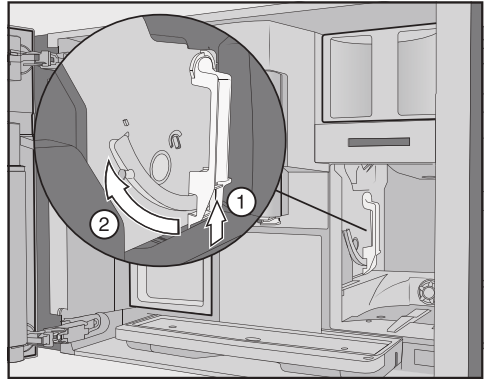

■ Press the button under the handle of the brew unit ① and, while doing so, turn the handle forward ②.

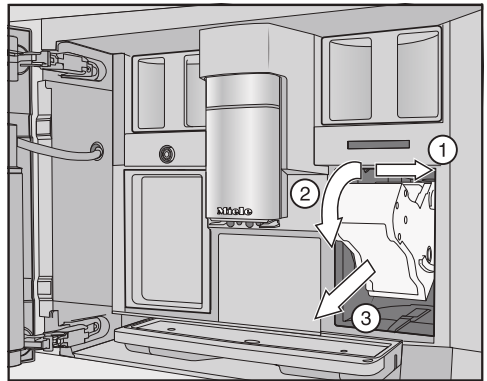

■ Pull the brew unit to the side ① first and then pull out to the front ②. Tilt the brew unit forward ③.

If you cannot remove the brew unit or can only do so with difficulty, the brew unit drive is not in the correct position.

Cleaning and care

Cleaning the brew unit and interior

The moving parts of the brew unit are lubricated. Cleaning agents will damage the brew unit.

Only clean the brew unit by hand with warm water. **Do not use any cleaning agents.**

To ensure good tasting coffee and to prevent a build-up of bacteria in the machine, remove and clean the brew unit under running water once a week.

- Clean the brew unit **by hand under warm running water** without using any cleaning agents.

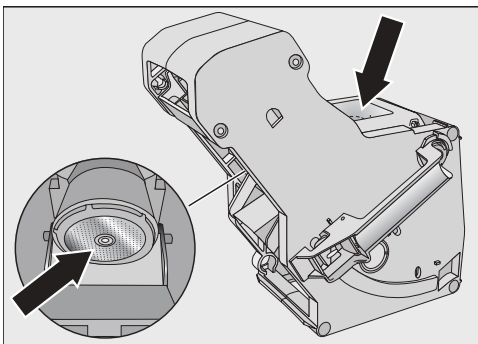

- Wipe any remaining coffee off the two filters. One filter is located in the funnel and the other to the left of the funnel.

The process of removing the brew unit causes ground coffee to drop into the drip tray.

- Remove the drip tray and clean the lid.
- Clean the interior of the coffee machine (see also “Cleaning and care – Removing the brew unit and cleaning it by hand”). Use a vacuum cleaner to remove dry ground coffee residues.

Dropping a cleaning tablet into the brew unit

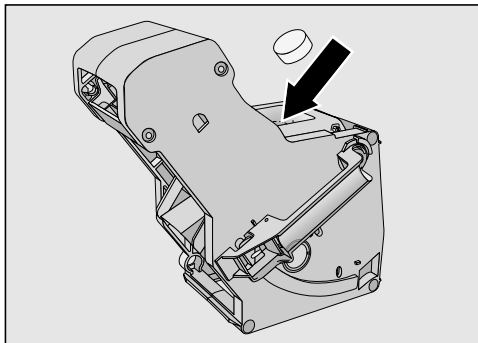

- Drop a cleaning tablet into the top of the brew unit (arrow).
- Push the brew unit containing the cleaning tablet back into the coffee machine.

If you cannot re-insert the brew unit, the brew unit drive is not in the correct position.

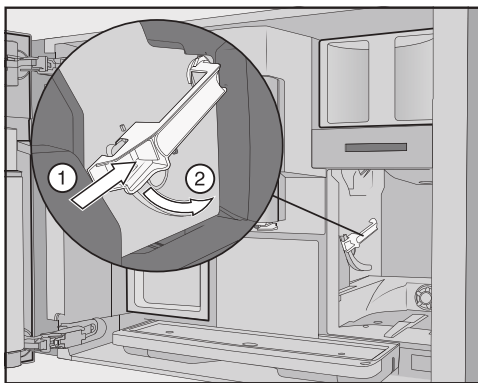

- Press the button under the handle of the brew unit ① and, while doing so, turn the handle backward ②.
- Push the water container and drip tray (plus grounds container) back into the coffee machine.
- Close the appliance door.

- Follow the additional instructions given in the display.

The cleaning process is complete when the drinks menu appears.

Descaling the appliance

Risk of damage from splashes from the descaling solution.

Sensitive surfaces and/or natural floors can suffer damage.

Wipe up any spillages immediately when descaling.

Limescale builds up in the coffee machine through use. How often the machine needs to be descaled will depend on the water hardness level in your area. Limescale must be removed regularly.

The machine will guide you through the descaling process. Various messages will appear in the display, e.g., you will be prompted to empty the drip tray or fill the water container.

Descaling **must be carried out**. The process takes approx. 35 minutes.

Even if you activate automatic descaling, the pipework may still have to be descaled manually with the *Descal* Appliance maintenance program at regular intervals, depending on how you use your machine.

If you have not inserted a descaling cartridge, the display will remind you when you need to descale the coffee machine.

No. of uses until appliance needs descaling: 50 will appear in the display. The remaining number of drinks that can be made before descaling will show in the display after each drink.

- Confirm the message with *OK*.

When the number of remaining portions reaches 0, the coffee machine will lock.

You can switch the coffee machine off if you do not want to carry out the descaling program at this point. You cannot make any drinks until the machine has been descaled.

Descaling after prompt appears in the display

Descal appliance will appear in the display.

- Confirm the message with *OK*.

The process will start.

- Follow the instructions in the display.

When Place 2 descaling tablets in the water container and fill it with lukewarm water up to the descaling symbol  and insert it appears in the display, proceed as follows.

For optimum descaling results, we recommend using the Miele descaling tablets.

The descaling tablets have been specially developed for Miele coffee machines.

Other descaling agents, which contain other acids besides citric acid and/or other undesirable substances, such as chlorides, may cause damage to the product. Moreover, the descaling result required cannot be guaranteed if the descaling solution was not of the appropriate concentration.

The descaling tablets are available to order from the Miele online shop.

You will need **2** descaling tablets.

Cleaning and care

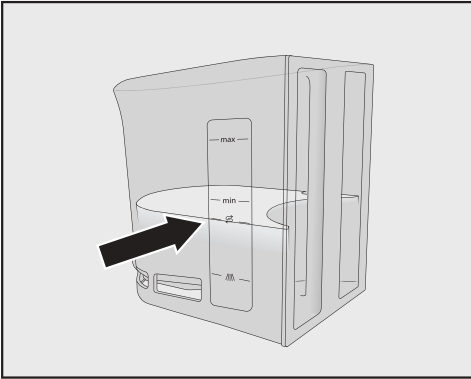

- Fill the water container to the **S** mark with lukewarm water.
- Add **2** descaling tablets to the water container.

Follow the instructions for the mixing ratio carefully. It is important that you do not fill the water container with too much or too little water. Otherwise the descaling process will be canceled prematurely.

Carrying out descaling

- Reinsert the water container.
- Follow the additional instructions given in the display.

When Rinse and refill the water container appears in the display:

- Remove the water container and rinse it thoroughly with clean water. Ensure that **no** descaling solution residue remains in the water container.
- Fill the water container with tap water.

The descaling process is complete when the drinks menu appears.

Automatic cleaning and descaling

Risk of damage from spilled cleaning and descaling solution.

Sensitive surfaces and/or natural floors can suffer damage.

One way to catch the cleaning and descaling solution is to place the maintenance container under the central spout before switching off the machine.

Clear up any spillages of cleaning and descaling solution.

When handling a descaling cartridge which has already been filled with water, ensure that the descaling solution does not come into contact with sensitive surfaces.

The coffee machine features automatic maintenance programs for cleaning the milk pipework and brew unit, and for descaling the machine. For this, the Miele Cleaning and Descaling Cartridges must be inserted into the coffee machine. If both types of maintenance program are due to run on the same day, automatic cleaning will always be performed before automatic descaling (total time: approx. 35 minutes).

You can set the time for starting cleaning and descaling via the Maintenance Timer.

The coffee machine will automatically determine the days when to carry out automatic descaling based on the usage pattern.

During automatic cleaning, the milk pipework gets cleaned and/or the brew unit gets degreased.

The coffee machine also determines the cleaning-solution concentration and the cleaning-program type for automatic cleaning based on the number and types of drinks made. If you do not

make any drinks, the automatic maintenance programs will not be started.

In order to run the automatic cleaning programs, a solution is prepared by mixing water with the cleaning agent. This solution is then pumped through the coffee-machine pipework. After the defined holding time, all the solution is rinsed out of the pipework and the machine can then be used as normal for making drinks.

During automatic cleaning and descaling, you will hear various noises (e.g., rinsing noises) at frequent intervals even though the machine is switched off.

What to ensure before and during automatic maintenance programs

The coffee machine must be ready to use and the following conditions must be met:

- Ready-to-use cleaning and descaling cartridges are inserted.
- Automatic cleaning is switched on.
- The coffee machine must **not** be disconnected from the power supply during the automatic maintenance programs.
- The drip tray, brew unit, and central spout are inserted.
- If filling the water container manually: the water container is inserted and is filled with water at least up to the  mark.
- Carry out the instructions which appear in the display before switching off, e.g., Empty and refill the drip tray and the waste container.

Automatic cleaning and descaling

- The machine door is closed when the program is started.
- The coffee machine is switched off.

Automatic cleaning

If you have made a drink containing milk, the milk pipework will be cleaned at least 4 days afterward.

If you have made a coffee, the brew unit will be degreased at least 15 days afterward.

Automatic cleaning takes approx. 25 minutes.

Switching automatic cleaning on and off

It is usual to switch on automatic cleaning as part of the process of setting up the coffee machine. However, Automatic Cleaning can be switched on or off at any time. The drinks menu is displayed.

- Tap the *Back* sensor button.
- Select *Settings* and then *Automatic Cleaning*.
- Select the setting you want and confirm with *OK*.

If coffee drinks and/or milk have already been dispensed when automatic cleaning is switched on, you will need to clean the coffee machine manually as a one-off operation. This will remove any milk residues and coffee oils, and will reset the counter.

The Miele Cleaning Cartridge

Only use the Miele Cleaning Cartridge for automatic cleaning. It has been developed specifically for use in this coffee machine.

Please note that the Miele Cleaning Cartridge has a life span of approx. 1 year after it has been placed in the coffee machine.

Critical for the one-year life span is the date on which the cleaning cartridge was inserted.

Do not fill the cleaning cartridge with other fluids or substances.

The Miele Cleaning Cartridge contains a cleaning agent for the effective removal of milk residues and coffee oils.

The Miele Cleaning Cartridge will last for up to 3 months of automatic cleaning, depending on how often the coffee machine is used. Frequent manual cleaning or a large number of drinks will shorten this period accordingly.

You can display the cartridge fill level as a segment bar under *Settings* | *Info* | *Fill levels*. As the cartridge fill level decreases, various messages will appear at regular intervals to remind you to have a new cartridge at the ready.

The first message will appear when the cartridge is approx. 25% full.

Cleaning cartridges are available to order from the Miele online shop, from Miele Technical Service, or from your Miele dealer.

Automatic cleaning and descaling

If **no** cleaning cartridge has been inserted or if the inserted cartridge is **empty** or has **expired**, the milk pipework and brew unit must be cleaned manually. For this, you will need the appropriate cleaning agents (see “Cleaning and care” – “Cleaning the milk pipework” and “Degreasing the brew unit”).

You can leave the cleaning cartridge in place during long periods of non-use or when transporting the coffee machine.

Replacing the cleaning cartridge

Cleaning cartridges are available to order via the Miele online shop, Miele Customer Service, or your Miele dealer.

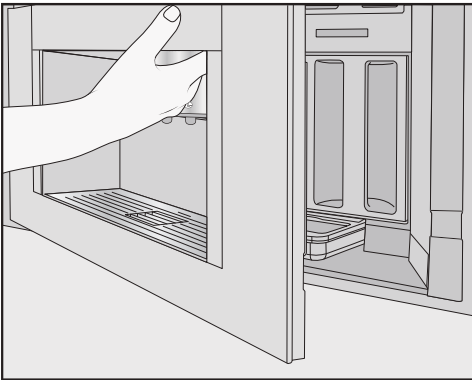

- Open the appliance door.
- Remove the maintenance container.

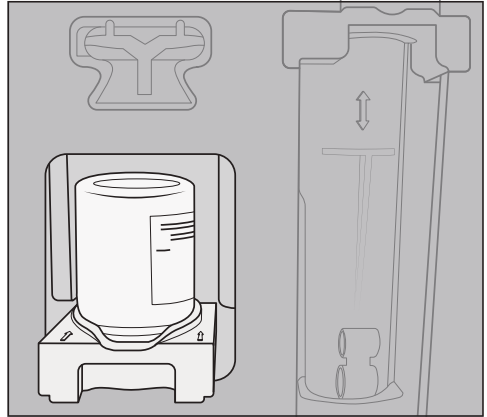

- Pull the holder with the cartridge forward and remove both.
- Unscrew the cleaning cartridge from the holder.
- Dispose of the used cartridge with your household waste.

Cleaning agent residues can sometimes dry on the holder, leaving white deposits behind. These residues will not affect the automatic cleaning program. If necessary, you can wipe the residues off with a damp cloth or put the holder in the dishwasher.

- Take the new cartridge out of its packaging.
- Unscrew the screw cap.

The cap is no longer required.

Automatic cleaning and descaling

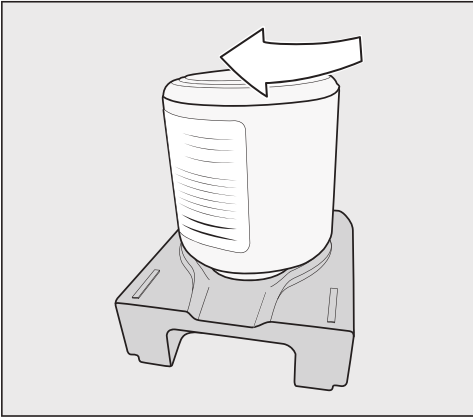

- Screw the new cartridge into the holder upside down.
- Push the holder and cartridge into the coffee machine until the holder audibly clicks into place.
- Put the maintenance container back inside the appliance.
- Close the appliance door.

Automatic descaling

Automatic descaling takes approx. 12 minutes.

To ensure the longevity of components and an environment that is consistently free of limescale, the coffee machine needs to be manually descaled from time to time. The intervals are determined by your usage behavior and the water-hardness level of your area. If you make a lot of coffees with milk, for example, you will need to descale the coffee machine more frequently with the descaling tablets.

The Miele descaling cartridge

Only use the Miele descaling cartridge for the automatic descaling program.

Please note that the Miele descaling cartridge has a service life of approx. 1 year after it has been placed in the coffee machine and filled with water for the first time. The date on which the descaling cartridge was installed and filled with water determines the one-year service life.

Do not install a descaling cartridge which has already been used in another Miele coffee machine. Your coffee machine will have no information about the fill level of this cartridge. The descaling effect may be insufficient and damage your coffee machine.

Do not fill the descaling cartridge with other fluids or substances.

The descaling agent comes in the form of tablets in the descaling cartridge. The cartridge is filled with water when it is placed in the coffee machine. The tablets gradually dissolve over time.

The descaling cartridge will last for 7 to 12 months of automatic descaling, depending on how often the coffee machine is used.

You can display the cartridge fill level as a segment bar under [Settings](#) | [Info](#) | [Fill levels](#). As the cartridge fill level decreases, various messages will appear at regular intervals to remind you to have a new cartridge at the ready.

The Miele descaling cartridge is available to order from the Miele online shop, from Miele Service, or from your Miele dealer.

Automatic cleaning and descaling

If a descaling cartridge is **not** installed, an **empty** cartridge is installed, or an **expired** cartridge is installed, the coffee machine needs to be descaled using the *Descale Appliance* maintenance program. To do this, the appropriate descaling agent is required (see “Descaling the machine” in “Cleaning and care”).

The descaling cartridge can remain installed even if the machine is not used for a long time. Remove the cartridge before transporting the coffee machine. However, please note the following:

- Once filled with water, the descaling cartridge has a maximum shelf life of max. 3 weeks outside of the coffee machine.
- The descaling cartridge should be transported with care and upright. Avoid shaking it. Shaking or turning upside down reduces the service life or damages the cartridge.
- The cartridge should be stored upright, in a dark place, and at room temperature (16–38°C).

Replacing the descaling cartridge

Removing the descaling cartridge

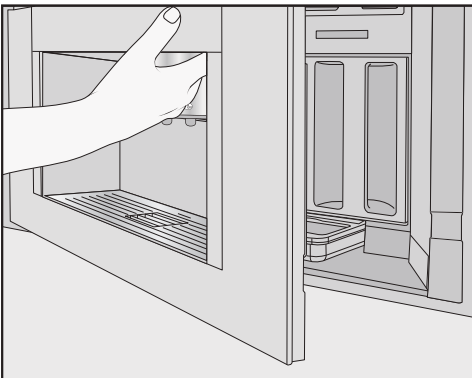

- Open the appliance door.
- Remove the maintenance container.

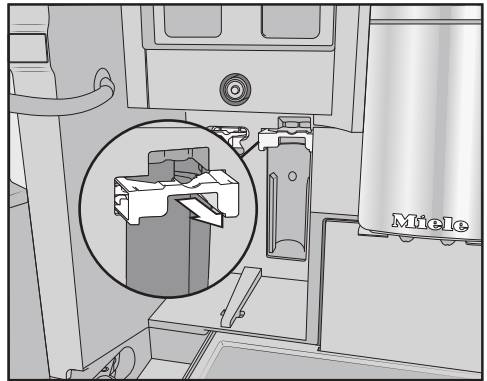

- Pull the cartridge holder forward.
- Remove the cartridge.

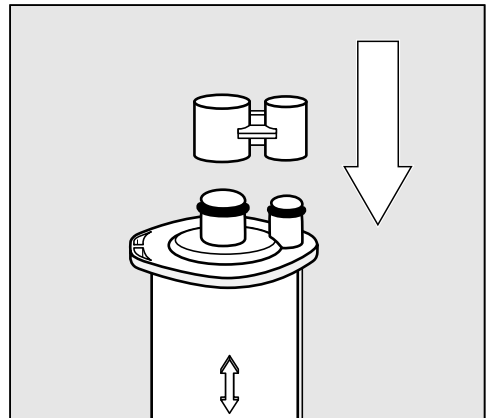

Tip: You can seal the descaling cartridge with the cap that can be found on the cartridge. This cap can be easily detached by snapping it off.

- Dispose of the cartridge with your household waste.

Inserting the descaling cartridge

- Insert the cartridge and push it upward as far as it will go.

Automatic cleaning and descaling

- Push the cartridge holder back and then put the maintenance container in place.
- Close the appliance door.
- Follow the instructions on the display.

The next time the coffee machine is switched off, the new descaling cartridge will also fill with water when the machine is rinsed. You will hear water being pumped into the cartridge at frequent intervals.

Always wait for the coffee machine to switch itself off. Do not force the machine to switch off.

Choosing not to use a descaling cartridge

If you do not want to insert a descaling cartridge, seal the system with the adapter.

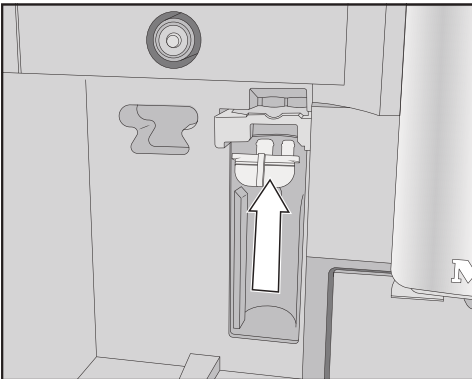

- Insert the adapter in place of the cartridge.

Maintenance Timer

In the Maintenance Timer, you can select any start time you like for the automatic maintenance programs.

Please note that the automatic maintenance programs can take a maximum of around 35 minutes to run. You can set different start times for the weekend and/or weekdays.

Setting the Maintenance Timer

The drinks menu is displayed.

- Touch the ↶ sensor control.
- Select Maintenance.
- Select Maintenance timer.
- Change the settings as required.
- Confirm with *OK*.

The start time is saved. From now on, the automatic maintenance programs will commence at the desired time each day.

Canceling automatic cleaning and descaling

You can cancel the automatic cleaning programs during the holding time.

If the automatic cleaning program is not performed **five times** in a row, the dispensing of drinks is blocked. You will only be able to make drinks again once the brew unit has been degreased and/or the milk pipework has been cleaned.

- Tap the On/Off switch ①.

The time left in hours is shown in the display.

- Tap Cancel.

The cleaning or descaling solution is rinsed out of the pipework. Rinsing can take up to 5 minutes. You can now make drinks.

Frequently asked questions

Many malfunctions and faults that can occur in daily operation can be easily remedied. You can save time and money in many cases, as you do not need to contact Miele Customer Service.

Information to help you rectify faults yourself can be found at www.miele.com/service.

The following tables are designed to help you to find the cause of a malfunction or fault and resolve it.

Messages in the display

Error messages must be confirmed with *OK*, otherwise the message may reappear in the display even though the problem has been remedied.

To address the fault, follow the instructions on the display.

If the error message appears in the display again, contact Miele Technical Service.

Problem	Possible cause and solution
F1, F2, F80, F82 F353, F354	There is an internal fault. ■ Switch the coffee machine off. Wait for approximately 1 hour before switching the machine back on again.
F74, F77 F225, F226 F235, F353, F354	There is an internal fault. ■ Switch the coffee machine off. Wait for approximately 2 minutes before switching the machine back on again.

Frequently asked questions

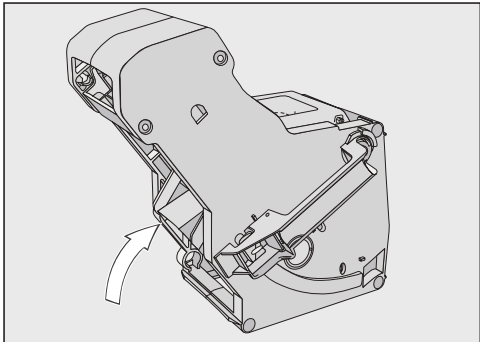
Problem	Possible cause and solution
<p>F73 or Check the brew unit</p>	<p>The brew unit cannot be positioned correctly or is soiled. It is not possible to press the ground coffee.</p> <ul style="list-style-type: none"> ■ Check whether you can remove the brew unit. ■ If you can remove the brew unit, rinse it under running water.  <ul style="list-style-type: none"> ■ Push the coffee ejector of the brew unit into the correct position (see image). ■ Replace the water container in the coffee machine and close the door. Do not insert the brew unit. Switch the coffee machine on. <p>This will initialize the brew unit motor and put it back into the start position.</p> <ul style="list-style-type: none"> ■ When Insert the brew unit appears in the display, put the brew unit back in the coffee machine. ■ If you cannot remove the brew unit, switch the coffee machine off. Wait for approximately 2 minutes before switching the machine back on again.
<p>A manual maintenance program is prematurely aborted and the following appears in the display: Push the water container in until it engages.</p>	<p>The water container has not been filled and inserted correctly.</p> <ul style="list-style-type: none"> ■ Check that you have selected the correct mark. <p>The symbols marked on the water container indicate the amount of water required for the Descale Appliance: ☉ and Clean the milk pipework: ☉ maintenance programs.</p> <ul style="list-style-type: none"> ■ Fill the water container up to the relevant mark and restart the process.

Frequently asked questions

Problem	Possible cause and solution
Check water intake and empty the water container	<p>The plumbed-water supply is not working.</p> <ul style="list-style-type: none"> ■ Check whether the intake hose is kinked or the water supply valve is not turned on completely. ■ Remove and empty the water container. ■ Insert the empty water container into the coffee machine. <p>The following message is displayed: Please wait. Water container filling. The water container fills up.</p> <p>To turn off the plumbed-water connection, fill and insert the water container. You can then select Settings: Main Water Off.</p>
F233	<p>The cup-rim sensor is not inserted or is incorrectly inserted.</p> <p>If the central spout is moving upward and the cup-rim sensor is bumped, e.g., with a cup, the cup-rim sensor loses its reference position.</p> <ul style="list-style-type: none"> ■ Confirm the message with <i>OK</i>. ■ Reinstall the cup-rim sensor. <p>Cup-rim detection remains inactive and the central spout stays in the top position until the coffee machine is next switched on. Cup-rim detection is reinitialized during the next switch-on operation.</p>
F 355, F 357–F 362	<p>The bean system must be set up again, e.g., coffee beans have possibly got jammed.</p> <ul style="list-style-type: none"> ■ Open the machine door and remove both bean containers from the coffee machine. ■ Close the machine door. <p>The bean system is set up.</p> <ul style="list-style-type: none"> ■ Follow the instructions on the display.
F 307 or Remove the milk valve and clean it	<p>The milk valve is faulty.</p> <ul style="list-style-type: none"> ■ Remove and clean the milk valve (see “Cleaning and care – Removing and cleaning the milk valve”).

Frequently asked questions

Unusual performance of the coffee system

Problem	Possible cause and solution
<p>The display remains dark when the coffee machine is turned on using the On/Off button ①.</p>	<p>The On/Off button ① was not held for long enough.</p> <ul style="list-style-type: none"> ■ Tap and hold the On/Off button ① for at least 3 seconds.
	<p>The plug is not properly plugged into the electrical socket.</p> <ul style="list-style-type: none"> ■ Insert the plug into the electrical socket.
	<p>The fuse has tripped because the coffee machine, voltage, or another appliance is defective.</p> <ul style="list-style-type: none"> ■ Remove the plug from the socket. ■ Contact a qualified electrician or Technical Service.
<p>The lighting remains off after the coffee machine has been switched on.</p>	<p>The lighting has been switched off.</p> <ul style="list-style-type: none"> ■ Switch the lighting on (see “Lighting” in the “Settings” chapter).
	<p>The lighting is faulty.</p> <ul style="list-style-type: none"> ■ Contact Technical Service.
<p>The time of day is being displayed but the ☀ sensor button and movement sensor are failing to respond.</p>	<p>This is not a fault. The QuickTouch function is switched off. Select Display QuickTouch On so that the ☀ sensor button and movement sensor respond even when the coffee machine is switched off.</p>
<p>The coffee machine does not respond to operation via the display.</p>	<p>There is a fault.</p> <ul style="list-style-type: none"> ■ Tap and hold the On/Off button ① until the display switches off and the machine restarts.
<p>The coffee machine turns off suddenly.</p>	<p>The factory-set switch-off time (20 minutes) or the switch-off time you have programmed has been reached.</p> <ul style="list-style-type: none"> ■ If required, you can select a new switch-off time (see “Settings – Timer”).
	<p>The plug is not properly plugged into the electrical socket.</p> <ul style="list-style-type: none"> ■ Insert the plug into the electrical socket.
<p>The sensor buttons do not respond. The coffee machine can no longer be operated.</p>	<p>There is an internal fault.</p> <ul style="list-style-type: none"> ■ Disconnect the coffee machine from the electricity supply by removing the plug from the socket or switching off the breaker.

Frequently asked questions

Problem	Possible cause and solution
<p>A fan can be heard even though no drinks are being prepared and the coffee machine is switched off.</p>	<p>This is not a fault. Once a drink has been dispensed or the machine has been switched off, the internal fan will continue to run until the interior is sufficiently dehumidified.</p>
<p>The coffee machine brew unit cannot be removed.</p>	<p>The brew unit drive is not positioned correctly.</p> <ul style="list-style-type: none"> ■ If necessary, turn the handle on the brew unit back to the start position. ■ Close the appliance door. ■ Switch the coffee machine off. ■ Wait approx. 1 minute before switching the coffee machine back on. <p>This will initialize the brew unit drive and put it back into the start position.</p> <ul style="list-style-type: none"> ■ If necessary, repeat these steps.
<p>The brew unit cannot be re-inserted into the coffee machine.</p>	<p>The brew unit drive is not positioned correctly.</p> <ul style="list-style-type: none"> ■ Close the appliance door. <p>This will initialize the brew unit drive and put it back into the start position.</p> <ul style="list-style-type: none"> ■ If necessary, repeat this step.
<p>Drink dispensing is prematurely aborted even though there is a container under the central spout.</p>	<p>This is not a fault. If the container has a very wide opening that prevents the cup-rim sensor from making contact with the edge of the container (e.g., in the case of a very large cup), the drink will be canceled. Use a different container or position the existing one so that the sensor can detect the rim.</p>

Frequently asked questions

Problem	Possible cause and solution
<p>Coffee dispensing is repeatedly interrupted and the message Fill the bean container appears in the display.</p>	<p>This is not a fault. The brew unit has not detected the ground coffee. Certain types of coffee produce a small amount of coffee when they are ground. Usually the grinder is set too fine and the amount is set to minimum.</p> <ul style="list-style-type: none"> ■ Confirm the message with <i>OK</i>. <p>If the display appears with all types of coffee:</p> <ul style="list-style-type: none"> ■ Set the grinder to a coarser setting (see “Grinder setting”). ■ Select a larger amount of coffee. <p>Don't forget to check any drinks changed in “User profiles”.</p> <p>If the message only appears when dispensing certain drinks:</p> <ul style="list-style-type: none"> ■ Check the amount of coffee set for this drink (see “Amount of coffee”). Select a larger amount of coffee. ■ You may also need to set a coarser grinder setting.
<p>The coffee machine does not switch itself on even though the On at setting has been activated for the timer.</p>	<p>The system lock is activated.</p> <ul style="list-style-type: none"> ■ Deactivate the system lock. <p>The current day of the week has not been selected.</p> <ul style="list-style-type: none"> ■ Check the timer settings and change these if necessary. <p>The coffee machine was not used after being switched on automatically three times in succession (vacation mode).</p> <ul style="list-style-type: none"> ■ Switch the machine on and dispense a drink. <p>The coffee machine does not switch on with the On at timer while automatic descaling is being carried out. This is not a fault. Select a different timer setting.</p>
<p>Steam is dispensed instead of water while preparing hot water or making tea.</p>	<p>It is likely that the wrong altitude has been set.</p> <ul style="list-style-type: none"> ■ Change the altitude settings (Settings Altitude). ■ If necessary, you can also change the temperature settings for the drinks (Drinks parameters).
<p>The display is hard to see or not legible.</p>	<p>The display brightness has been set too low.</p> <ul style="list-style-type: none"> ■ Change this setting (see “Settings”).

Frequently asked questions

Problem	Possible cause and solution
The display lights up but the coffee machine does not heat up and no drinks are made.	<p>The Demo mode for demonstrating the coffee machine in stores and showrooms has been activated.</p> <ul style="list-style-type: none"> ■ Deactivate Demo mode (see “Settings”).

Faults with automatic cleaning and/or descaling

Problem	Possible cause and solution
After switching on, a message appears informing you that automatic cleaning and/or descaling could not be carried out.	<p>The coffee machines was not ready for operation: all removable parts, such as the water container, drip tray, brew unit, or central spout must be installed.</p> <p>The water container was not filled with drinking water at least up to the descaling symbol ☞.</p> <p>The machine door was not closed.</p> <ul style="list-style-type: none"> ■ Confirm the message with <i>OK</i>. ■ Make sure that the coffee machine is ready to use before the next automatic cleaning and/or descaling process.
	<p>The coffee machine was not switched off at the start time.</p> <p>The automatic maintenance programs will only start if the coffee machine is switched off.</p> <ul style="list-style-type: none"> ■ Confirm the message with <i>OK</i>. ■ Change the start time if necessary.
Descalce appliance appears even though a ready-to-use descaling cartridge has been inserted. Drinks cannot be made.	<p>Depending on the water hardness level in your area and your usage behavior, the coffee machine will occasionally need to be descaled using the maintenance program.</p> <p>For this you will need to use a suitable descaling agent, e.g., Miele Descaling Tablets.</p> <ul style="list-style-type: none"> ■ Descalce the coffee machine using the maintenance program (see “Descaling the machine” in “Cleaning and care”).

Frequently asked questions

Problem	Possible cause and solution
<p>When the machine is switched on, one of these messages appears: Automatic cleaning could not be carried out. Start Automatic cleaning (duration min.) now? Otherwise Automatic cleaning will be permanently turned off.</p> <p>or: Automatic maintenance could not be carried out. Carry out the Automatic cleaning part of the Automatic maintenance program (duration min.) now? Otherwise the Automatic cleaning part of the Automatic maintenance program will be permanently turned off</p> <p>No drinks can be made.</p>	<p>Automatic cleaning could not be carried out five times.</p> <p>If you want the coffee machine to continue cleaning the milk pipework and degreasing the brew unit automatically:</p> <ul style="list-style-type: none"> ■ Make sure that the coffee machine is ready for automatic maintenance (see “Automatic cleaning and descaling”). ■ Tap <i>OK</i> to start automatic cleaning. <p>If you select <i>No</i> to switch automatic cleaning off, you will have to clean the milk pipework and degrease the brew unit manually (see “Cleaning and care”). For this, you will need the cleaning agent for milk pipework and the tablets for degreasing the brew unit.</p>

Unsatisfactory results

Problem	Possible cause and solution
<p>The coffee is not hot enough.</p>	<p>The cup has not been pre-heated. The smaller the cup and the thicker its walls, the more important it is to pre-heat it.</p> <ul style="list-style-type: none"> ■ Pre-heat the cup with hot water, for example.
	<p>The brewing temperature is set too low.</p> <ul style="list-style-type: none"> ■ Set a higher brewing temperature.
	<p>The filters in the brew unit are blocked.</p> <ul style="list-style-type: none"> ■ Remove the brew unit and clean it by hand. ■ Degrease the brew unit.

Frequently asked questions

Problem	Possible cause and solution
<p>The coffee grinder makes a louder noise than usual.</p>	<p>The coffee bean container has become empty during the grinding process.</p> <ul style="list-style-type: none"> ■ Fill the coffee bean container with fresh beans. <p>There may be foreign objects such as plastic or stones in amongst the coffee beans.</p> <ul style="list-style-type: none"> ■ Switch the coffee machine off immediately. Contact the Technical Service department.
<p>The coffee is dispensed too slowly into the cup.</p>	<p>The brew unit is blocked.</p> <ul style="list-style-type: none"> ■ Degrease the brew unit (see “Cleaning and care – Degreasing the brew unit and cleaning the interior”).
<p>The crema on the coffee or espresso is not as it should be.</p>	<p>The coffee beans are no longer fresh. If roasted coffee beans are stored open for too long, the carbon dioxide gradually escapes from the coffee beans. The crema is no longer formed during dispensing. Of course, you can still use the coffee beans.</p>
<p>The coffee tastes weak. The coffee grounds in the grounds container are sludgy and grainy.</p>	<p>Less coffee is being brewed because insufficient coffee beans are getting into the grinder. Have you used a dark roast?</p> <p>This type of coffee bean is often oily. These oils can cling to the walls of the coffee bean containers and hinder the flow of beans.</p> <p>Are you using a type of coffee with very large beans or different sized beans?</p> <p>The beans are possibly getting wedged or jammed and forming “bean bridges”.</p> <ul style="list-style-type: none"> ■ Clean the coffee bean containers more often if you are using darker, more oily coffee beans. ■ If you are using a type of coffee with very large beans or different sized beans, pull the bean containers out slightly and give them a shake. ■ If necessary, try using a different type of coffee.
<p>Coffee is not being dispensed from both dispensers evenly. Milk may be sputtering when being heated up.</p>	<p>Coffee deposits in the central spout prevent the dispensing of the drinks.</p> <ul style="list-style-type: none"> ■ Take the central spout apart and wash all the components – with the exception of the stainless steel cover – in the dishwasher. This cleaning operation should be performed once a week.

Frequently asked questions

Problem	Possible cause and solution
<p>The consistency of the milk froth is unsatisfactory.</p>	<p>The milk temperature is too high. Good milk froth can only be achieved when cold milk (below 50°F/10°C) is used.</p> <ul style="list-style-type: none"> ■ Check the temperature of the milk in the milk flask. <p>The milk pipework is blocked and/or the milk valve is soiled.</p> <ul style="list-style-type: none"> ■ Remove and clean the milk valve.
<p>Coffee drinks trickle/dribble slowly out of the central spout.</p>	<p>The brew unit is blocked because the coffee machine has been used very intensively. And/or the brew unit has not been regularly removed and cleaned by hand.</p> <ul style="list-style-type: none"> ■ If a cleaning cartridge is inserted, start by switching off Automatic Cleaning (Settings Automatic Cleaning). ■ Run the Degrease the brew unit maintenance program with 1 cleaning tablet (see “Cleaning and care – Degreasing the brew unit and cleaning the interior”). <div data-bbox="400 703 878 1046" data-label="Image"> </div> <ul style="list-style-type: none"> ■ It is particularly important to clean the filters in the brew unit thoroughly. ■ If necessary, switch on Automatic Cleaning before you start making a drink. <p>Otherwise, the Clean the milk pipework and Degrease the brew unit maintenance programs will have to be run again.</p>

Information to help you rectify faults yourself and about Miele spare parts can be found at www.miele.com/service.

Contact in the event of a fault

In the event of a fault which you cannot remedy yourself, please contact your Miele dealer or Miele Customer Service.

You can book a Miele Service Call online at www.miele.com/service.

Contact information for Miele Customer Service can be found at the end of this document.

Please quote the model identifier and serial number of your appliance (SN) when contacting Miele Customer Service. Both pieces of information can be found on the data plate.

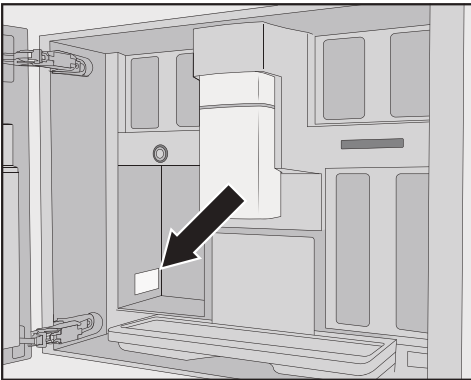

Appliance warranty and product registration

You can register your product and/or view the manufacturer's warranty terms and conditions for Miele appliances and vacuum cleaners at www.mieleusa.com.

Accessories

These products and other useful accessories can be ordered via the Miele Webstore, from Miele Service or from your Miele dealer.

- **Cleaning agent for milk pipework**
for cleaning the milk system
- **Cleaning tablets**
for degreasing the brew unit
- **AutoCleaner**
for automatically cleaning the milk pipework and brew unit
- **Descaling cartridge**
for automatic descaling
- **Descaling tabs**
for manual descaling
- **CJ Jug 1.0 L**
Insulated flask for coffee or tea (pot function)
- **Miele Black Edition One for all**
perfect for making espresso, café crema, and speciality coffee with milk
- **Miele Black Edition Espresso**
Whole coffee beans – perfect for making espresso
- **Miele Black Edition Café Crema**
Whole coffee beans – perfect for making coffee

Disposal of the packing material

The cardboard box and packing materials protect the appliance during shipping. They have been designed to be biodegradable and recyclable.

Ensure that any plastic wrappings, bags, etc. are disposed of safely and kept out of the reach of children. Danger of suffocation!

Saving energy

The following tips can help you save energy and money as well as help the environment:

- Operate the coffee machine in Eco mode (default setting).
- Switch off the time of day display.
- Select a lower lighting setting or refrain from using any lighting.
- Switch off the lighting when the appliance is switched off.
- Select the dark colour scheme for the display.
- Reduce the brightness of the display.
- If you change the factory default settings for the "Timer", this can increase the energy consumption of the coffee machine.
- Pay particular attention to the following message on the display: This setting increases energy consumption.
- Switch the coffee machine off with the On/Off switch ① if it is not going to be used for a while.

Disposal of your old appliance

Electrical and electronic appliances contain valuable materials. They also contain certain substances, compounds and components which were essential for the proper functioning and safe use of the equipment. Handling these materials improperly by disposing of them in your household waste can be harmful to your health and the environment. Therefore, please do not dispose of your old appliance with regular household waste and follow local regulations on proper disposal.



Consult with local authorities, dealers or Miele in order to dispose of and recycle electrical and electronic appliances. Miele assumes no responsibility for deleting any personal data left on the appliance being disposed. Please ensure that your old appliance is kept away from children until removal. Observe safety requirements for appliances that may tip over or pose an entrapment hazard.

Installation

Plumbed water connection

 Risk of injury and appliance damage if appliance is not connected properly.

Failing to connect the appliance properly can result in personal injury and/or material damage.

The appliance may only be connected to the plumbed-water connection by qualified specialists.

 Risk to health and risk of damage due to contaminated water.

The quality of the incoming water must conform to the requirements for drinking water in the country where the coffee machine is being used.

Connect the coffee machine to the water supply.

Connection to the water supply must comply with the applicable regulations in the country where the appliance is being installed. All units and systems used to supply water to the coffee machine must also comply with the applicable regulations in the respective country.

Connect the coffee machine directly to the plumbed-water supply.

Avoid connecting the coffee machine to a water supply in which the water might stagnate. Otherwise, the flavor of the drinks could be impaired.

The coffee machine may only be connected to a cold-water supply.

The water-connection pressure needs to be between 100 and 1,000 kPa (14.5 to 145 psi).

A water supply valve must be provided between the stainless-steel hose and the domestic-water supply to ensure that the water supply can be cut off if necessary. Make sure the water supply valve remains easily accessible once the coffee machine has been installed.

Connecting the appliance to the water supply line

Make sure that the supply line is not kinked or damaged.

A 3/4" BSP to 1/4" compression fitting adapter is supplied with the machine. Suitable 1/4" O.D flexible water line or copper piping is not included.

- Remove the water connection cover from the bottom of the back panel of the machine.
- Take the **angled** side of the brass fitting and check whether a gasket is present. If not, insert one.
- Screw the supply line coupling nut onto the threaded union.
- Ensure that the supply line is correctly fitted and that it is water-tight.

Connecting the water supply

 Disconnect the coffee machine from the power supply before connecting it to the water supply. Turn off the water supply at the water supply valve before connecting the coffee machine to the water supply.

Make sure that the water supply valve remains accessible after the machine has been installed.

To connect the coffee machine to the water supply, a water supply valve with a 3/4" connection is required.

- Check that a seal is present. Install one if necessary.

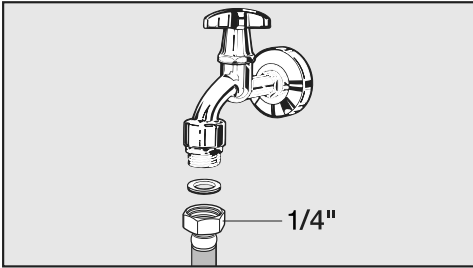

- Connect the stainless-steel hose to the water supply valve.
- Ensure that it is screwed into position correctly.
- Turn on the water supply valve slowly and check for leaks at the plumbed-water connection. Correct the position of the seal and screw thread if appropriate.

You can now continue installing the coffee machine.

Electrical connection

Before connecting the coffee machine, make sure that the connection data on the data plate (voltage and frequency) matches the electrical supply. This data must match to avoid the risk of damage to the coffee machine. If in any doubt, consult a qualified electrician.

The necessary connection data is given on the data plate inside your appliance.

The fuse rating must be at least 15 A.

If possible, the socket should remain easily accessible. If the socket is no longer accessible after installation, an additional means of disconnection must be provided for all poles. Suitable means of disconnection include switches with an all-pole contact gap of at least 1/8" (3 mm).

Temporary or permanent operation on an autonomous power supply system or a power supply system that is not synchronized with the grid power supply (e.g., island networks, backup systems) is possible. A prerequisite for operation is that the power supply system complies with local regulations and standards.

The function and operation of the protective measures provided in the domestic electrical installation and in this Miele product must also be maintained in isolated operation or in operation that is not synchronized with the grid power supply, or these measures must be replaced by equivalent measures in the installation.

As described, for example, in the current version of VDE-AR-E 2510-2.

The coffee machine must not be used with **energy saving plugs**. These reduce the energy supply to the machine, which could generate excessive heat.

Installation

Installation dimensions

Installation in a tall cabinet

Observe the required minimum installation height of $33 \frac{7}{16}$ " (850 mm).

Your coffee machine can be installed flush or proud. Discuss your requirements with your architect, kitchen designer, and installer.

More installation drawings are available on the Miele homepage.

Combination with other Miele built-in appliances is possible. If the coffee machine is to be built in above another appliance, there must be a full-width, closed shelf between them. If the appliance is to be combined with a Gourmet warming drawer/built-in vacuum drawer, no shelf is required in between.

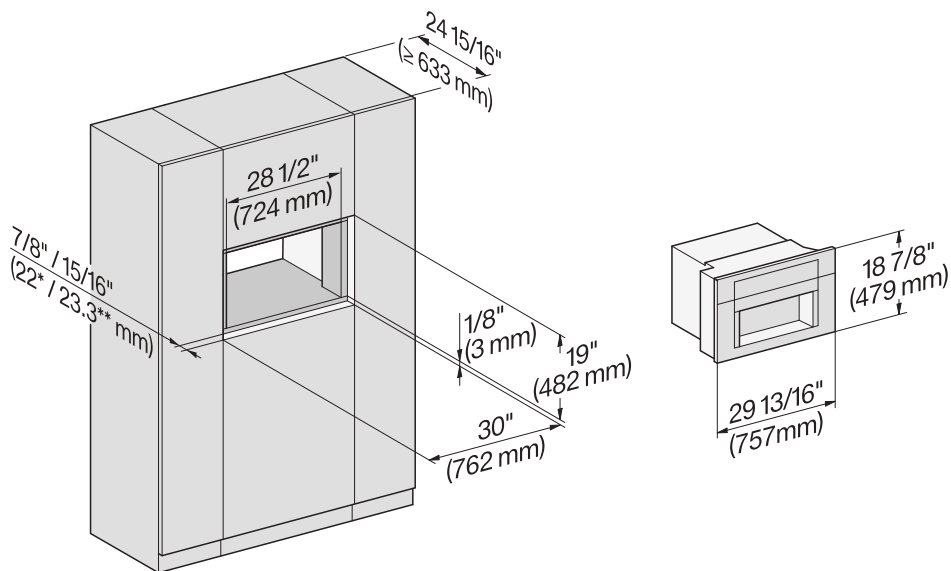

Installation and connections

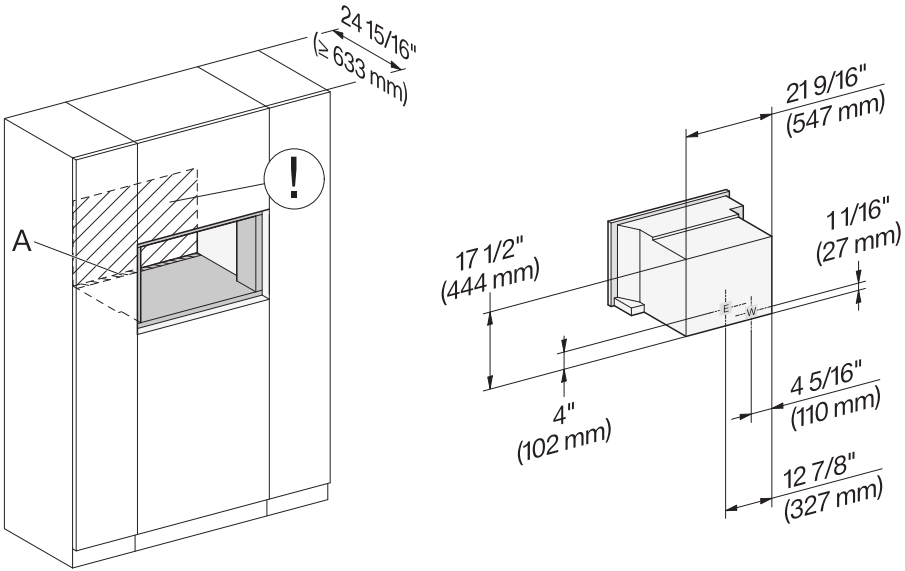

- A** Cut-out (at least 20"/508 mm wide) in the base of the tall cabinet for power cord and ventilation
- E** Electrical connection
- W** Plumbed-water connection
- Ⓛ No electrical or plumbed-water connection in this area

Installation

Building in the coffee machine

 Danger of injury due to incorrect operation.

A machine that has not been built in is not safe and can cause injuries.

Do not operate the coffee machine unless it has been built in.

 Danger of damage due to incorrect operation.

If the ambient temperature range is not observed, the coffee machine can not function properly.

The coffee machine may only be operated within an ambient temperature range of +60°F to +100°F (+16°C to +38°C).

Maintain the required minimum installation height of 33 7/16" (850 mm).

 Risk of damage and injury from the coffee machine tipping over.

If the coffee machine is not yet screwed to the cabinet, the appliance may tip forward when the appliance door is open.

Make sure that a second person fully secures the coffee machine during installation.

First screw the top-left screw to the cabinet.

Risk of damage due to the use of an electric screwdriver.

If the coffee machine is secured with an electric screwdriver, e.g., cordless screwdriver, the chuck may damage the appliance door and/or the interior.

Only use a manual screwdriver to secure the coffee machine in the cabinet.

To install the machine, you will need a TX 20 screwdriver.

Tip: We recommend providing a place to sit the coffee machine which is the same height as the building-in niche. This will make it easier to connect the appliance to the electricity and water supply.

Connecting the plumbed-water and electricity supplies

Observe the information under "Plumbed-water connection" and "Electrical connection".

- Connect the coffee machine to the plumbed-water and electricity supplies.

Tip: We recommend providing a place to sit the coffee machine which is the same height as the building-in niche. This will make it easier to connect the machine to the electricity and water supply.

Removing transport restraints

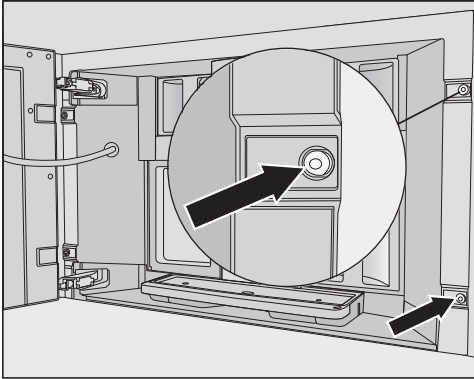

2 screw holes are fitted with red silicone plugs to protect the appliance against transport damage and secure the door during transport.

Remove the plugs **before** screwing the coffee machine to the cabinet unit.

- Pull firmly on the red silicone plugs to remove them from the screw holes.

The plugs are not required for any other purpose. Dispose of them with your household waste.

Pushing in and aligning the coffee machine

When pushing the machine into the niche, make sure that the electrical and plumbed-water connections do not get trapped or damaged.

- Push the coffee machine all the way into the niche until you feel a resistance.
- Check the height of the coffee machine to make sure that it is sitting centrally in the niche and that it is level. Align the machine.

Never align the coffee machine by adjusting the door hinges. This will prevent the milk flask from attaching correctly and interfere with the milk-preparation process.

Screwing the coffee machine to the cabinet

Four TX20 (25 mm) screws are supplied with the machine.

- Open the appliance door.

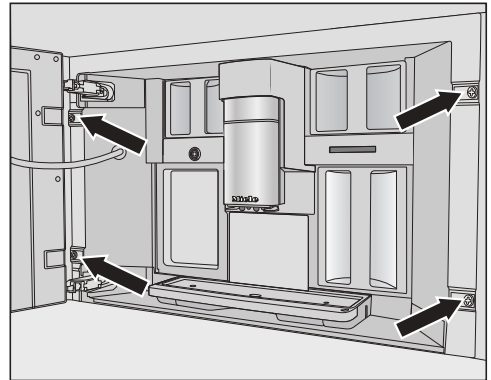

- Secure the coffee machine to the side walls of the cabinet using the screws supplied. Start with the top-left screw. Proceed in a clockwise direction to tighten the other screws. Tighten all screws by hand.
- Carry out a functional check on the coffee machine.

Technical data

Electricity consumption in standby:	$\leq 0.8 \text{ W}$
-------------------------------------	----------------------

Electricity consumption in networked standby:	$\leq 1.4 \text{ W}$
-----------------------------------------------	----------------------

Frequency range	2.412 GHz – 2.462 GHz
-----------------	-----------------------

Maximum transmitting power	$< 100 \text{ mW}$
----------------------------	--------------------

FCC Declaration of Conformity



0483491

Wi-Fi module EK057

Contains FCC ID: 2AC7Z-EK057

Contains IC: 21098-EK057

This device complies with Part 15 of the FCC Rules and with Industry Canada licence-exempt RSS standard(s). Operation is subject to the following two conditions: (1) this device may not cause harmful interference, and (2) this device must accept any interference received, including interference that may cause undesired operation.

This equipment complies with FCC radiation exposure limits set forth for an uncontrolled environment. This equipment should be installed and operated with minimum distance 8" (20 cm) between the radiator and your body. This device and its antenna(s) must not be co-located or operation in conjunction with any other antenna or transmitter.

Industry Canada Statement

This digital apparatus does not exceed the Class B limits for Radio Noise Emissions from digital apparatus set out in the Radio Interference Regulations of the Canadian Department of Communications.

Complies with Canadian ICES-003 Class B specifications.

Copyrights and licenses

For the purpose of operating and controlling the communication module, Miele uses proprietary or third-party software that is not covered by open source licensing terms. This software/these software components are protected by copyright. The copyrights held by Miele and third parties must be respected.

In addition, the integrated communication module contains software components which are distributed under open source licensing terms. You can access these open source components along with the associated copyright notices, copies of the valid licensing terms, and any additional information locally via IP using a web browser ([http\[s\]://<ip address>/Licenses](http[s]://<ip address>/Licenses)). The liability and warranty arrangements for the open source licenses displayed in this location only apply in relation to the respective rights holders.

Please have the model and serial number
of your appliance available when
contacting Customer Service.

U.S.A.

Miele, Inc.

National Headquarters

9 Independence Way
Princeton, NJ 08540
www.mieleusa.com

Customer Support

Phone: 888-99-MIELE (64353)
info@mieleusa.com

International Headquarters

Miele & Cie. KG
Carl-Miele-Straße 29
33332 Gütersloh
Germany

Canada

Importer
Miele Limited

Headquarters and Miele Centre

161 Four Valley Drive
Vaughan, ON L4K 4V8
www.miele.ca

Customer Care Centre

Phone: 1-800-565-6435
905-532-2272
contact@miele-support.ca

CVA 7775, CVA7875

en-US, CA

M.-Nr. 12 861 300 / 02