



AGA R7

**Includes Hotcupboard
(External Vent & Room Vent Option)**

User Guide & Installation Instructions

REMEMBER, when replacing a part on this appliance, use only spare parts that you can be assured conform to the safety and performance specification that we require.

DO NOT use reconditioned or copy parts that have not been clearly authorised by AGA.



**PLEASE READ THESE INSTRUCTIONS BEFORE USING THIS APPLIANCE
AND KEEP IN A SAFE PLACE FOR FUTURE REFERENCE.**



For use in USA & CAN

Make a note of your AGA R7 Serial Number when it is being installed. The serial number can be found behind the magnetic plinth cover.

My AGA Details:

Serial No: _____
AGA Service No: _____
Date of Installation: _____

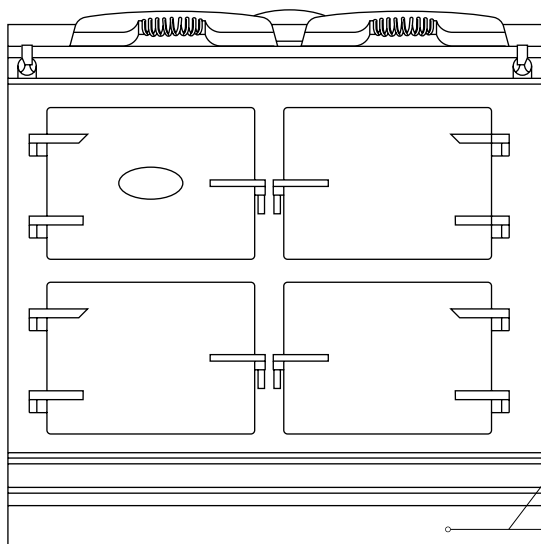





| |
|--|
| SERIAL NO. NO DE SERIE |
| AGA GAS RANGE: DCS 0 |
| THIS RANGE COMPLIES WITH ANSI Z21.1 - 2010 HOUSEHOLD COOKING APPLIANCES WITH THE EXCEPTION OF SECTION 13 ON HEAT DISTRIBUTION. ALSO COMPLIES WITH CSA B 59 1006. |
| CE FORMALIS DE CUISINE EST CONFORME A LA NORME ANSI Z21.1 - 2010 APPAREILS DE CUISISON MENAGERES. A L'EXCEPTION DE LA SECTION 13 DISTRIBUTION DE LA CHALEUR DU FOUR. IL EST AUSSI CONFORME A LA NORMA CSA B 59 1006. |
| VENTED UNIT. SEE INSTALLATION INSTRUCTIONS. ENTRÉ VENTILÉE. VOIR INSTRUCTIONS D'INSTALLATION. |
| CONTROL VALVE ENTRY SIZE VIE DE DISTRIBUTION REGULATEUR MISE AU GAZ |
| MAXIMUM BURNER RÉGULATEUR BRÛLEUR |
| MAXIMUM GAS PRESSURE PRESSION EXTENSION DU GAZ |
| 240V 60Hz 22AMPS |
| MAX HEAT INPUT (APPORT THERMIQUE) MAX Max Gas (Gaz Naturel): 6500 Btu/h |
| AGA, STATION ROAD, KETLEY, TELFORD, SHROPSHIRE, TF1 5AG, ENGLAND |

Data badge located
behind removable
plinth

Contents

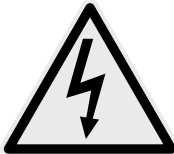
| | | | |
|---|-----------|--------------------------------------|-----------|
| 1. Product Safety | 1 | 11. Installation instructions | 19 |
| 2. Health & Safety | 3 | 12. Installation requirements | 20 |
| 3. Introduction | 5 | 13. Location | 21 |
| 4. Overview | 6 | 14. Clearances | 22 |
| AGA R7 100 | 6 | AGA R7 100 | 24 |
| AGA R7 150 | 7 | AGA R7 150 | 25 |
| 5. How to use your AGA R7 | 8 | 15. Power Supply connections | 26 |
| Getting to know your AGA | 8 | AGA Hotcupboard connections | 27 |
| Oven Controls | 9 | 16. Mains Supply Location | 28 |
| Hotplate Controls | 10 | Mains cable routing | 28 |
| Operating the ovens | 10 | Mains cable routing- AGA Hotcupboard | 29 |
| Operating the Hotcupboard | 11 | 17. Hotcupboard installation | 30 |
| General Advice | 12 | 18. Circuit diagram | 37 |
| 6. Equipment supplied with your AGA eR7 | 13 | R7 Circuit diagram | 37 |
| 7. Fitting and Removing the oven shelves | 15 | AGA R7 (HOTCUPBOARD) | 38 |
| 8. Fitting and removing the oven doors | 16 | | |
| 9. Cooking on your AGA | 17 | | |
| 10. Cleaning & Caring | 18 | | |

1. Product Safety

| Meaning / Description | Symbol | Signification / Description |
|---|---|--|
| <p>WARNING / CAUTION</p> <p>An appropriate safety instruction should be followed or caution to a potential hazard exists.</p> |  | <p>AVERTISSEMENT</p> <p>Une consigne de sécurité appropriée doivent être suivies ou garde d'un danger potentiel exists.</p> |
| <p>DANGEROUS VOLTAGE</p> <p>To indicate hazards arising from dangerous voltages.</p> |  | <p>TENSION DANGEREUSE</p> <p>Pour indiquer les dangers résultant des tensions dangereuses.</p> |
| <p>PROTECTIVE EARTH (GROUND)</p> <p>To identify any terminal which is intended for connection to an external conductor for protection against electric shock in case of a fault, or the terminal of a protective earth (ground) electrode.</p> |  | <p>TERRE DE PROTECTION</p> <p>Pour marquer bornes destinées à être raccordées à un conducteur de protection extérieur contre les chocs électiques en cas de défaut d'isolement, ou pour marquer la borne de la terre de protection.</p> |
| <p>HEAVY</p> <p>This product is heavy and reference should be made to the safety instructions for provisions of lifting and moving.</p> |  | <p>LOURD</p> <p>Ce produit est lourd et doit être fait référence aux consignes de sécurité relatives aux dispositions de soulever et déplacer.</p> |
| <p>DISCONNECT MAINS SUPPLY</p> <p>Disconnect incoming supply before inspection or maintenance.</p> |  | <p>APPAREIL À LASER DE CLASSE 2</p> <p>Alimentation d'entrée Débrancher avant inspection ou d'entretien.</p> |
| <p>REFER TO MANUAL</p> <p>Refer to relevant instructions detailed within the product manual.</p> |  | <p>ATTENTION, SURFACE TRÈS CHAUDE</p> <p>Reportez-vous aux instructions applicables, indiquées dans le manuel du produit.</p> |

Important Safety Instructions



INCORRECT USE OF THIS RANGE CAN INCREASE THE RISK OF FIRE, ELECTRIC SHOCKS OR INJURY TO PERSONS.

PLEASE READ THE FOLLOWING PRECAUTIONS TO REDUCE THESE RISKS.

This appliance is not intended for use by persons (including children) with reduced physical, sensory or mental capabilities, or lack of experience and knowledge, unless they have been given supervision or instruction concerning use of the appliance by a person responsible for their safety.

ALWAYS



Always make sure children are never left alone or unsupervised when the range is on.

Always be aware that range surfaces will be hot during and after use and can cause burns.

Always teach children that the range and utensils can be hot.

Always allow heavy and hot utensils to cool in a safe place and out of reach of small children.

Always be aware hot grease is flammable. Wipe off any grease deposits on the range top and front.

In the event of a grease fire, do not remove the pan, cover the pan to extinguish the flame.

Always turn utensil handles inwards but not cover adjacent heated surfaces, to prevent accidental spillage and burns.

Always when opening an oven door, allow hot air and steam to escape.

Always use dry pot holders. Moist pot holder will cause steam burns. Do not use towels or other cloths near the heated plates.

Always clean ventilation hoods frequently, grease should not be allowed to accumulate in hood and filters.

Always make sure cabinet and work surface are capable of supporting heavy cooking utensils used on your range.

Always make sure cooking utensils are suitable for range top service. Only certain types of glass, glass ceramic earthenware/glazed utensils with stand sudden temperature changes without breaking.

Always make sure your appliance is properly installed and grounded by a qualified technician.

Always make sure your appliance is serviced by a qualified technician.



NEVER

Never store items of interest to children above the range.

Never allow children to climb on, sit or stand on any part of the range.

Never allow children to play with the controls or any part of the range.

Never wear loose fitting clothing or other flammable materials that could contact hot surfaces on the range.

Never leave boiling pans unattended, boil over causes smoking and greasy spillovers may ignite.

Never store gasoline or other volatile liquids in the range or in cabinets above or near the range, which can catch fire or explode.

Never use water on grease fires. Smother fire or flame or use a dry chemical or foam type extinguisher.

Never use your appliance for warming or heating the room.

Never repair or replace any part of the appliance unless recommended in this manual. All other servicing should be carried out by a qualified technician.

Never cover or restrict the air flow to the controls compartment.

Never install cabinets (shelves) or similar above the range with a depth greater than 13" (330mm).

Never heat unopened food containers. Pressure build-up may cause the container to burst and cause injury.

Never reach directly into a hot oven to add or remove cooking utensils. Instead pull the grid shelf out to its maximum projection.

Never use a steam cleaner to clean your range.

Never use a power spray or oven cleaners on the control panel.

Never use caustic cleaners, abrasive pads or metal scrapers to clean enamel surfaces.

2. Health & Safety

Consumer Protection

As a responsible manufacturer, we take care to make sure that our products are designed and constructed to meet the required safety standards when properly installed and used.

NOTE: The installation manual and user guide for this appliance are available online on www.agaliving.com.



INCORRECT USE OF THIS RANGE CAN INCREASE THE RISK OF FIRE, ELECTRIC SHOCKS OR INJURY TO PERSONS.

PLEASE READ THE FOLLOWING PRECAUTIONS TO REDUCE THESE RISKS.

- This appliance is not intended for use by persons (including children) with reduced physical, sensory or mental capabilities, or lack of experience and knowledge, unless they have been given supervision or instruction concerning use of the appliance by a person responsible for their safety.
- Children should be supervised to ensure that they do not play with the appliance.
- **PLEASE READ THE ACCOMPANYING WARRANTY.** Any alteration that is not approved by AGA could invalidate the approval of the appliance, operation of the warranty and could also affect your statutory rights.
- **YOUNG CHILDREN SHOULD BE KEPT AWAY FROM THE APPLIANCE AS SURFACES CAN BECOME HOT TO TOUCH.**



ALWAYS

- Children are more sensitive to heat than adults.
- Always make sure children are never left alone or unsupervised when the range is on.
- Always be aware that range surfaces will be hot during and after use and can cause burns.
- Always teach children that the range and utensils can be hot.
- Always allow heavy and hot utensils to cool in a safe place and out of reach of small children.
- Always be aware hot grease is flammable. Wipe off any grease deposits on the range top and front.
- Do not leave containers of cooking fat around the range.
- In the event of a grease fire, do not remove the pan, cover the pan to extinguish the flame.

- Always turn utensil handles inwards but not cover adjacent heated surfaces, to prevent accidental spillage and burns.
- Always when opening an oven door, allow hot air and steam to escape.
- Always use dry pot holders. Moist pot holder will cause steam burns. Do not use towels or other cloths near the heated plates.
- Always clean ventilation hoods frequently. Grease should not be allowed to accumulate in hood and filters.
- Always make sure cabinet and work surface are capable of supporting heavy cooking utensils used on your range.
- Always make sure cooking utensils are suitable for range top service. Only certain types of glass, glass ceramic earthenware/glazed utensils with stand sudden temperature changes without breaking.
- Always make sure your appliance is properly installed and grounded by a qualified technician.
- Always make sure your appliance is serviced by a qualified technician.



NEVER

- Never store items of interest to children above the range.
- Never allow children to climb on, sit or stand on any part of the range.
- Never allow children to play with the controls or any part of the range.
- Never wear loose fitting clothing or other flammable materials that could contact hot surfaces on the range.
- Never leave boiling pans unattended, boil over causes smoking and greasy spillovers may ignite.
- Never store gasoline or other volatile liquids in the range or in cabinets above or near the range, which can catch fire or explode.
- Never use water on grease fires. Smother fire or flame or use a dry chemical or foam type extinguisher.
- Never repair or replace any part of the appliance unless recommended in this manual. All other servicing should be carried out by a qualified technician.

- Never cover or restrict the air flow to the controls compartment.
- Never install cabinets (shelves) or similar above the range with a depth greater than 13" (330mm).
- Never heat unopened food containers. Pressure build-up may cause the container to burst and cause injury.
- Never reach directly into a hot oven to add or remove cooking utensils. Instead pull the grid shelf out to its maximum projection.
- Never use a steam cleaner to clean your range.
- Never use a power spray or oven cleaners on the control panel.
- Never use caustic cleaners, abrasive pads or metal scrapers to clean enamel surfaces.
- Never use aluminium foil as a protective liner on the oven base, except as suggested in the manual. Improper use of this type of liner may create a risk of fire.

Deep Fat Frying

- Use a deep pan.
- Never fill the pan more than one-third full of fat or oil
- Never use a lid on the pan.
- **Important:** Oil is a fire risk, do not leave pans containing oil unattended.
- In the event of a fire, cover the pan with a lid and turn OFF the appliance.
- Do not try to fry too much food at a time, especially frozen food. This only lowers the oven temperature of the oil or fat too much, resulting in greasy food.
- Always dry food thoroughly before frying, and lower it slowly into the hot oil or fat. Frozen foods in particular, will cause frothing or spitting, if added too quickly.
- Never heat fat, or fry with a lid on the pan.
- Keep the outside of the pan, clean and free from streaks of oil or fat.

Smother the flames on the hob preferably with a fire blanket, rather than attempting to remove the pan to the outside.

Burns and injuries are caused almost invariably by picking up the burning pan to carry it outside.

Do not hang dish towels on the left hand side of the AGA handrail. Doing so will block the air vent. Blocking the air vent can cause excessive temperature increase to the control panel and prevents easy access to the controls.

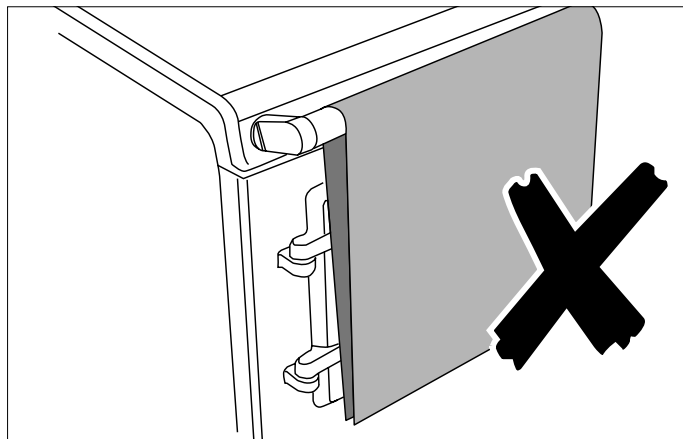

When the oven(s) are on **DO NOT** leave any oven door open for long periods, this will effect the temperature of the oven and may allow controls to become hot.

A little smoke and some odor may be emitted when the appliance is first switched on. This is normal and harmless (from oven lagging and starch binder on the element insulation) and will cease after a short period of use.

CAUTION: The Control System of your AGA will, because of regulatory compliance requirements, implement a software reset at 2.00 am local time. The reset process will turn off the external vent fan. If you have at any time manually set the vent fan to be ON, please check its operation before you commence cooking.

3. Introduction

As responsible manufacturers we take care to make sure that our products are designed and constructed to meet the required safety standards when properly installed and used.

Your new AGA gives you everything you love about the AGA heat storage cooker, but with the added convenience that the two hotplates can be turned on or off, as required.

Refer to the diagram in the Overview chapter to familiarise yourself with the product and refer to the relevant sections for the ovens, plates, controls etc.

Made in the heart of Shropshire, your AGA cooker, like the generations of cookers before it, has been manufactured from cast iron. Traditional iron-making skills combined with industrial strength hotplate elements enable the hotplates to heat up rapidly, so you can have them both on, or just one on, depending on the time of day or the size of your family.

Any alteration that is not approved by AGA could invalidate the approval of the appliance, operation of the warranty and could affect your statutory rights.

In the interests of safety and effective use, please read the following before using your new AGA appliance.

Ensure that the kitchen is well ventilated: keep natural ventilation holes open or install a mechanical ventilation device (mechanical extractor hood).

Prolonged intensive use of the appliance may call for additional ventilation, for example, opening of a window, or more effective ventilation, for example increasing the level of mechanical ventilation where present.

Installation must be to local and national wiring regulations and carried out by a qualified engineer.

A little smoke and some odour may be emitted when first switched on. This is normal and harmless (from oven lagging and starch binder on the element insulation) and will cease after a short period of use.

4. Overview

WARNING: ACCESSIBLE PARTS MAY BECOME HOT DURING USE. TO AVOID BURNS AND SCALDS CHILDREN SHOULD BE KEPT AWAY.

AGA R7 100

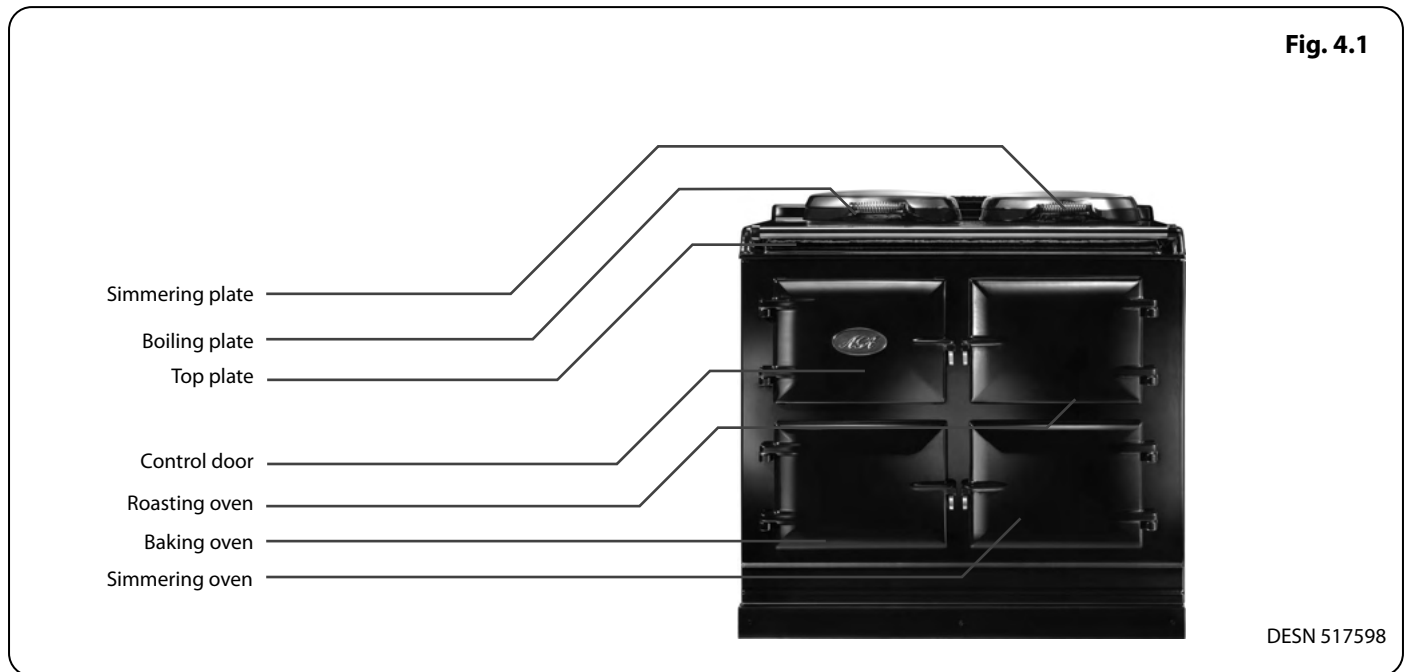

The AGA R7 has the traditional cast iron ovens with independently controlled hotplates.

Hotplates

The two hotplates are at different heats; the boiling plate being the hottest of the two and the simmering plate is a lower heat. Each plate is individually controlled.

Boiling Plate

The boiling plate is used for making toast, boiling a kettle, stir-frying and cooking at a higher heat.

Simmering Plate

The simmering plate is for slower cooking, such as sauces, simmering pans and can also be used to cook on directly for toasted sandwiches, drop scones, no-fat fried eggs and quesadillas.

Roasting Oven

The hottest oven for high temperature cooking; pastries breads, roasting of meat, vegetables and poultry, grilling at the top of the oven and frying on the base of the oven.

Baking Oven

A moderate oven for cooking cakes and biscuits, baking fish, lasagne or shepherds pie, plus roasting meat and poultry at a medium heat. Cooking sweet and savoury dishes together is no problem as the flavours do not mix.

Simmering Oven

Long, slow cooking in the simmering oven develops flavours and makes the toughest meat tender. It's large capacity means several pans can be stacked here; soup, casserole, steamed rice, steamed carrots and poached fruits all cooking simultaneously, without any danger of burning.

From cold the ovens will take several hours to achieve normal operating temperature.

WARNING: ACCESSIBLE PARTS MAY BECOME HOT DURING USE. TO AVOID BURNS AND SCALDS CHILDREN SHOULD BE KEPT AWAY.

AGA R7 150

Fig. 4.2



The AGA R7 150 has the traditional cast iron ovens with independently controlled hotplates.

Hotplates

The two hotplates are at different heats; the boiling plate being the hottest of the two and the simmering plate is a lower heat. Each plate is individually controlled.

Boiling Plate

The boiling plate is used for making toast, boiling a kettle, stir-frying and cooking at a high heat.

Simmering Plate

The simmering plate is for slower cooking, such as sauces, simmering pans and can also be used to cook on directly for toasted sandwiches, drop scones, no-fat fried eggs and quesadillas.

Roasting Oven

The hottest oven for high temperature cooking; pastries, breads, roasting of meat, vegetables and poultry, grilling at the top of the oven and frying on the base of the oven.

Baking Oven

A moderate oven for cooking cakes and biscuits, baking fish, lasagne or shepherds pie, plus roasting meat and poultry at a medium heat. Cooking sweet and savoury dishes together is no problem as the flavours do not mix.

Simmering Oven

Long, slow cooking in the simmering oven develops flavours and makes the toughest meat tender. It's large capacity means several pans can be stacked here; soup, casserole, steamed rice, steamed carrots and poached fruits all cooking simultaneously, without any danger of burning.

NOTE: From cold the ovens will take several hours to achieve normal operating temperature.

Warming Plate (Hotcupboard)

The warming plate is the ideal resting place for cooked food.

Slow Cooking Oven (Hotcupboard)

Ideal for a broad range of long slow cooking applications, such as leg of lamb, pulled pork, belly pork and celebration cake.

NOTE: Meat and vegetable dishes should be started on the boiling plate or in the roasting oven.

Warming Oven (Hotcupboard)

Used for warming plates and serving dishes. Can also be used for resting joints before carving.

5. How to use your AGA R7

Getting to know your AGA

If you have not already seen a demonstration, ask your AGA Specialist for details. A demonstration will show you how to get the best from your new AGA and will give you hints and tips. You will also see a selection of AGA utensils and accessories being used.

To get the very best performance from your cooker we recommend AGA saucepans with heavy 6mm Superthermic encapsulated base and stacking lids so that the maximum use of oven space is made and an AGA kettle for boiling water

Top Plate

The top plate is the enamelled surface surrounding the hotplates. It will become warm when the R7 hotplates are in use. Although it is not a cooking surface you can use the warmth for a number of useful activities, which more often than not save time and washing-up! These include warming honey or syrup in the jar, or melting butter or chocolate in a basin - so saving on melting over a saucepan - but please put the basin on a cork mat or folded piece of kitchen towel to avoid scratching the enamel. Although it is durable and hard-wearing surface vitreous enamel is glass and will show scratch marks!

The top plate when warm can also be used to rest a cup of coffee or tea or dry off awkwardly shaped tins, peelers or food mixer and processor parts.

Hotplates

The hotplates operate separate from the ovens and are independent of each other.

The boiling plate is on the left hand side and the simmering plate is on the right hand side of the R7. The boiling plate is the hottest with the simmering plate being the cooler of the two. They both have electric elements embedded into the cast iron which heat up in approximately 11 and 8 minutes respectively. The hotplates can be used completely independently from the ovens.

This means the R7 differs from the traditional AGA heat storage cooker in that they can be used for the entire cooking time of appropriate dishes because the design keeps the hotplates at a constant heat, whereas the traditional AGA cooker continues to cook on a falling heat so for these we recommend starting on the hotplates then transferring to the ovens, this can be done with the R7 but is not necessary. For instance, if making a pasta dish with sauce on the R7, it can all be done on the hotplates.

The whole hotplate area can be used for cooking and several pans can be accommodated on a single plate at any one time. The hotplates are set very slightly above the top plate to avoid accidental scratching if the pans are pulled to one side. **DO NOT** drag the utensils from one plate to another as the enamel will suffer!

The stainless steel insulated covers are brought down over the hotplates when they are not in use. When the hotplates are 'on' the insulated covers will be warm. We strongly advise not to put anything such as kettles, saucepans or baking tins directly onto the insulated covers because they will show any scratches - invest in a pair of chef's pads to protect the surface if the covers are to be used as resting places!

Keep the hotplates clear of any burnt on food or crumbs by brushing with the wire brush, supplied with your AGA. Cleaning details can be found on "**Cleaning & Caring**" page **18**.

The different zones of the AGA R7 cooker are described in the following pages.

The traditional AGA heat storage cooker is famous for the gentle warmth it emits; with the AGA R7 you will get warmth only when the cooker is on or warmth, to a lesser degree, when only parts of it are on.

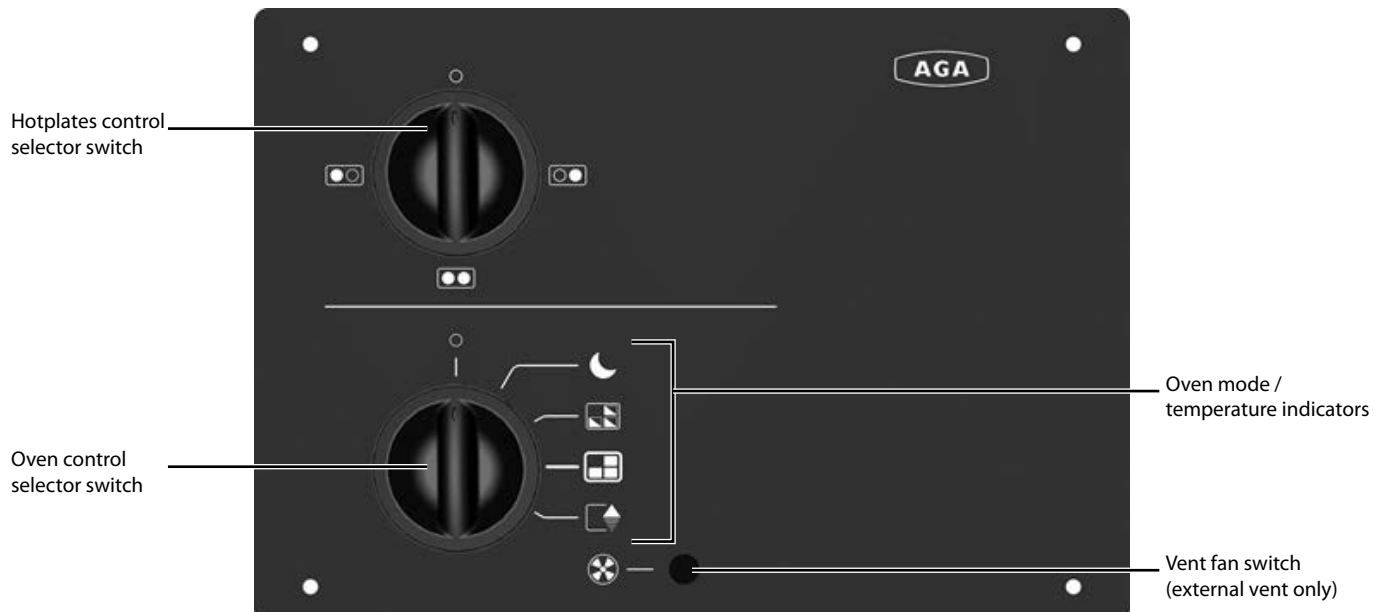

Oven Controls

Your AGA R7 has three ovens which operate as one creating three distinct cooking zones.

The Roasting Oven for high temperature cooking

The Baking Oven for moderate temperature cooking

The Simmering Oven for long, slow cooking

⚠ DO NOT OPERATE THE APPLIANCE WITH THE DOORS OPEN.

Each oven has the same capacity, (able to fit a 13kg (28lb) turkey). The AGA heat-storage cooker techniques can be used such as stacking of saucepans in the simmering oven. This enables the steaming of root vegetables, rice, steamed pudding, casserole, poaching fruit all in the one oven leaving the hotplates free and reducing steam and cooking smells in the kitchen.

The ovens are made from cast iron, which cooks by radiant heat, and this is the secret of the cooking excellence for which the AGA cooker is renowned. An indirect radiant heat does not dry food out, so it retains its natural moisture and flavour.

The oven control has four mode settings to choose from:



Normal – for everyday use, maintains the ovens at a temperature suitable for roasting, baking and simmering in the respective ovens.



Low – for reduced temperature cooking (50°F lower than normal). To achieve the lower cooking temperature from normal, allow 2 ½ hours before intended use. To return normal cooking temperature from this mode allow approximately 2 hours before intended use.



High – for higher temperature cooking (50°F higher than normal). To achieve the higher cooking temperature from normal, allow 2 hours before intended use. To return to normal cooking temperature from this mode allow approximately 2 ½ hours before intended use.





Slumber – maintains all ovens at a lower temperature to reduce energy consumption. To achieve normal cooking temperature from this mode allow approximately 3 ½ hours before intended use.



Oven temperature indication

For each mode the respective icon will flash while warming up, once the desired temperature is reached the respective icon will be illuminated 'solid' red. The icon remains 'solid' and does not flash when cooling down between modes.

Hotplate Controls

To operate the boiling plate turn the control knob to the  position and similarly to  the for the simmering plate.

To turn both plates on turn knob to  position.

Boiling Plate

The hottest hotplate, the boiling plate is used for boiling, griddling, stir-frying, making toast - indeed anything that requires a high heat. Green vegetables keep their colour when boiled quickly here, or use a steamer over the saucepan to cook more than one vegetable at once.

When stir-frying or cooking anything that is inclined to splash we would recommend using an AGA Splash Shield which will protect the insulated cover from splatter, making cleaning a doddle! Just wash the Splash Shield in hot soapy water or place in a dishwasher between two dinner plates.

Please be advised the boiling plate is too hot to cook food on directly.

Simmering Plate

The simmering plate is the cooler of the two hotplates and so is used for recipes that require a lower heat such as making sauces, scrambling eggs, heating milk, slow frying, simmering soups and root vegetables. In addition, it can be used to cook on directly as a form of griddle - invaluable for toasted sandwiches, quesadillas, soups, drop scones, searing scallops and even a non-fat fried egg. Slow cooked toast can be made on the simmering plate, no need here to use the AGA toaster.

The same size as the boiling plate, the simmering plate is also machined flat to give the best all-over contact with the AGA saucepans, grill pan, frying pan and kettle.

Cleaning details can be found on **“Cleaning & Caring” page 18.**



Operating the ovens

The Roasting Oven

The roasting oven can be used for ‘grilling’ at the top and ‘shallow frying’ on the oven floor.

The roasting oven is zoned in heat, meaning it is slightly hotter towards the top than the centre and the oven grid shelf set on the oven floor is slightly less hot than the centre.

The beauty of the roasting oven is that any fat splashes are burnt off when the oven is at full heat, just brush out occasionally to get rid of carbon deposits.

The roasting oven is excellent for bread and pastries. Quiches in ceramic or pies in Pyrex dishes need not be baked blind as when they are placed on the base of the oven, the pastry cooks from underneath and the filling will set and brown from the all-round heat. As you are aware metal flan tins conduct heat quicker than ceramic so may need less cooking time.

The Baking Oven

This oven is set at a moderate heat, so is ideal for cakes, biscuits and also anything that requires medium heat cooking such as fish pie, lasagne, soufflés, crumble and roulades. Meat and poultry can be cooked here in fact most things that can be cooked in the roasting oven can be cooked in the baking oven but for a longer time.

Cook cakes together on one shelf, if two shelves are used interchange the food to achieve even colouration, as you would with any oven which is zoned in heat.

As with the roasting oven the specially designed roasting tins and bakeware slide directly onto the runners, so almost every available square centimetre of space can be used. Food can be protected by the use of the cold plain shelf or shielded by means of the large roasting tin, which means that you can cook food that requires different temperatures at the same time.

If food is browning too quickly and you do not want to move it to another oven just slide the cold plain shelf over the food to reduce the top heat.

NOTE: Always remove the cold plain shelf and roasting tins on completion of cooking. If left in the oven it will affect the oven temperature.

When using the roasting oven for a long period of time i.e. a full meal, the baking oven temperature may rise, it will therefore be necessary to adjust the cooking procedure, the following suggestions may prove useful.

1. When placing the food in the baking oven, ensure the cold plain shelf is set directly above the dish, for the whole of the cooking time.
2. In addition it may be necessary to lower the shelf position.
3. When baking food, such as very rich fruit cakes, which require a long period of cooking time, place the cake on the fourth grid shelf position of the oven with

the cold plain shelf set directly above for 3/4 hour approximately. Move the plain shelf to the middle of the simmering oven. Transfer the cake to this shelf and bake until cooked through.

4. Alternatively, allow the baking oven to cool for approximately 4 hours before using.

NOTE: A loose metal perforated plate is positioned in the top of the baking oven in order to optimise cooking performance. It must remain in place at all times while the cooker is in operation.

The Simmering Oven

The simmering oven can be described as a continuation oven, it continues to cook food that has been brought up to heat elsewhere on the cooker with the exception of meringues which are dried out rather than 'cooked'.

- To get the very best performance, we recommend to use the AGA cookware with thick bases and stacking lids.
- Joints of meat and poultry should be brought up to heat ideally in the roasting oven for 30 - 45 minutes, then transfer to the simmering oven. This method is unsuitable for stuffed meat and poultry.
- Make sure that pork and poultry reach an internal temperature of at least 167°F.
- Always bring soups, casseroles and liquids to the boil before putting in the oven.
- Always thaw frozen food completely before cooking.
- Root vegetables will cook better if cut into small pieces.
- Adjust seasonings and thickenings at the end of the cooking time.
- Many dried pulses and beans for example, dried red kidney beans must be boiled for a minimum of 10 minutes, after soaking, and before inclusion in any dish.

Operating the Hotcupboard

Slow Cooking Oven and Warming Oven (Fig. 5.2)

These ovens are heated by a single element at the rear of the oven cavity. It is operated by a single push ON-OFF button located on the left hand side of the hotcupboard top plate and can be turned ON and OFF when required. These ovens are not cast iron on the interior.

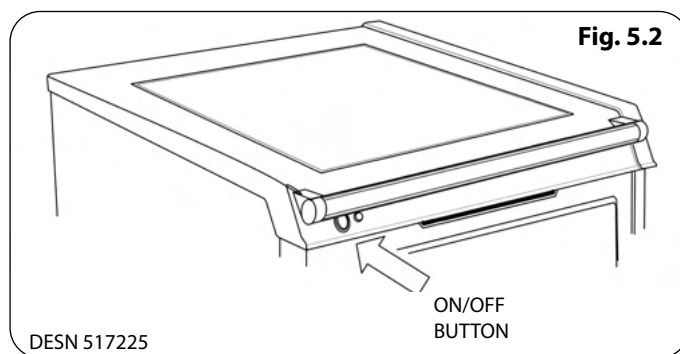

Slow Cooking Oven

This oven has similar characteristics to the simmering oven and should be utilised in a similar manner. It delivers a gentler convected heat making it better suited for longer cooking times especially for overnight cooking, for example rich fruit cakes and celebration cakes. The cooking of meringues may also be better suited for this oven.

NOTE: These ovens vent into the room, mechanical venting to the outside is not available.

Points to remember when Slow Cooking:

- Pre-heat the ovens for 30 minutes before starting to cook.
- Bring casseroles, soups etc. to the boil on the hotplate and start meat in the roasting oven, before placing in the slow cooking oven.
- Make sure that casseroles have sufficient liquid, particularly when cooking over a long period.
- Use lids on casseroles or foil to cover food whilst it is cooking to retain moisture.
- Make sure all dishes will fit into the oven before preparing food.
- Make sure that meat and poultry is piping hot before eating and reaches 167°F internal temperature.
- Always thaw frozen food completely before cooking.

You can also produce crisp, white meringues cooked in the slow cooking oven.

Timings for cooking in the slow cooking oven will depend upon the temperature, quantity and type of dish you are cooking, as a guide for casseroles, a minimum of 2 hours cooking time is recommended.

Keep an eye on the food until you are familiar with the oven.

The slow cooking oven can be described as a continuation oven, it continues to cook food that has been brought up to heat elsewhere on the cooker with the exception of meringues which are dried out rather than 'cooked'.

General Advice

When first switched on, the AGA will emit an odour for a short while. This is simply due to protective oil burning off the hotplates. Wipe the inside of the lids whilst the AGA is heating up to avoid a film of this oil being deposited on the inside.

The following points are intended to help in adapting to the AGA style of cooking during the change-over from a previous non-heat storage cooker. The AGA book provides a very useful introduction to the cooker.

For the most effective operation of the cooker, the following points should be carefully observed:

1. Close the insulating covers whenever the hotplates are not in use.
2. Clean the hotplates regularly with the wire brush.
3. Utensils with flat bases must be used to make perfect contact with the hotplate.
4. Take care when closing the oven doors, to lift them onto the catch.
5. Cook as much as possible in the ovens so that heat is conserved and cooking smells and condensation are reduced.
6. The oven doors should not be left open for long periods of time during cooking and heating up.

The roasting oven can also be used for 'grilling' and 'shallow frying' on the oven floor.

- For optimum cooking performance, use the AGA utensils and cast iron cookware. They have flat bases which give the best contact with the hotplates.
- The AGA pans can be stacked in the simmering oven. This is especially useful for steaming vegetables and keeping sauces warm.
- Store the plain shelf out of the AGA. Use it cold in the roasting oven to deflect the heat from the top of the oven, creating a more moderate oven temperature underneath. It can also be used as a baking sheet.
- A guide to AGA cooking is given on "**Cooking on your AGA**" page 17. Ask your AGA Specialist for an invitation to an AGA demonstration.

6. Equipment supplied with your AGA R7

Getting to know your AGA R7

If you have not already seen a demonstration, ask your AGA Specialist for details. A demonstration will show you how to get the best from your new AGA and will give you hints and tips. You will also see a selection of AGA utensils and accessories being used.



Large Size Roasting Tin with Grill Rack

This is designed to slide onto the oven runners without the need for it to sit on an oven grid shelf. The roasting tin can be used with the grill rack, in its high position, for grilling at the top of the roasting oven. It can be used for roasting meat, or poultry with or without the grill rack. Large quantities of roast potatoes can be cooked in this tin. The roasting tin can also be employed for making large traybakes or cakes. The grill rack is useful on its own as a cake cooling rack. Can be used in any oven but not recommended for hotplate use.

Half Size Roasting Tin and Grill Rack

This tin can be slid onto the oven runners width-ways or can sit on an oven grid shelf. The half size roasting tin can be used with the grill rack, in its high position, for grilling at the top of the roasting oven. It can be used for roasting smaller joints of meat, or poultry with or without the grill rack. Roast potatoes can be cooked in this tin. The roasting tin can also be employed for making traybakes or cakes. The grill rack is useful on its own as a cake cooling rack. It can be used in any oven but not recommended for hotplate use.

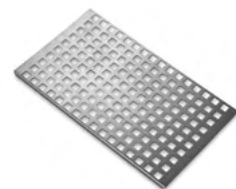
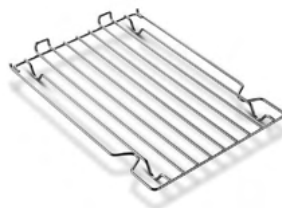

1 Floor Grid

This grid is used on the floor of the ovens, in particular the roasting and simmering ovens to protect food needing over 30 minutes cooking from the intensity of the heat from the base element.

3 Oven Grid Shelves

These are for inserting in each oven to provide a surface for dishes and tins which do not fit direct onto the oven runners. They can be used in any oven, as required. **“Fitting and Removing the oven shelves” page 15** on how to locate the oven shelves correctly.

Roasting Oven Baffle

A roasting oven perforated baffle is positioned in the top of the roasting oven, in order to optimise cooking performance. For best results, please ensure it is in place at all times, while the oven is in operation, including when grilling. The Installation Engineer will fit this in place. This can also be removed for cleaning.



Toaster

This is for toasting bread on the boiling plate. AGA toast is renowned for its excellence, crisp on the outside and soft in the centre. Take thick slices of bread and place in the AGA toaster - if the bread is very moist or very fresh, heat the toaster beforehand to prevent sticking - lift the boiling plate insulated cover and place the toaster direct onto the plate with the handle at an angle from the handle of the cover.

Close the cover and wait for the bread to toast one side - this will take 1-2 minutes dependent upon the variety of bread - open the cover and turn the toaster over and repeat the process to toast the other side. The toaster can also be used for heating pitta bread, toasting teacakes and as a cake cooling rack.



1 Cold Plain Shelf

This has two uses one as large baking sheet for scones, biscuits, pastry items and meringues and the other use as a heat deflector to cut off the top heat if food is overbrowning before it is cooked through.

⚠ DO NOT STORE IN THE OVENS WHEN NOT IN USE.



Wire Brush

This is for cleaning the raw cast iron hotplate surfaces, keeping them clear of crumbs and burnt on debris - which would otherwise affect the boiling performance of pans and the kettle. Use on the hotplates and the ovens. Take care not to touch the enamel surfaces as the wire brush will scratch the finish.



AGA Utensils and Accessories

To get the very best performance from your cooker we recommend AGA saucepans with the thick flat bases and stacking lids so that the maximum use of oven space is made and an AGA kettle for boiling water.

7. Fitting and Removing the oven shelves

Fitting the shelves for cast iron, roasting, baking and simmering ovens

Fig. 7.1

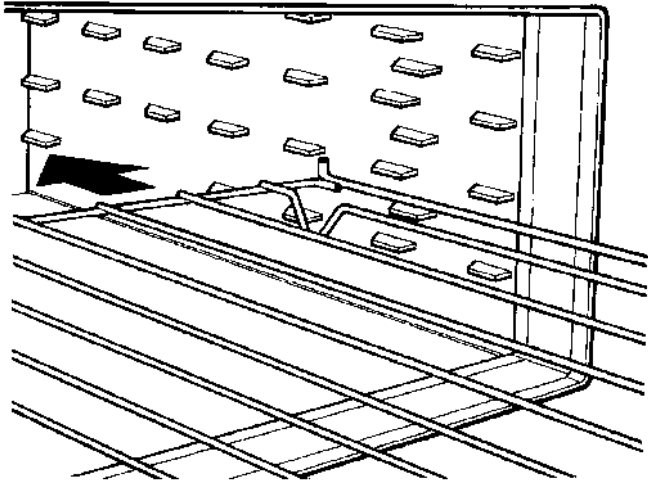

DESN 512403

Fig. 7.2

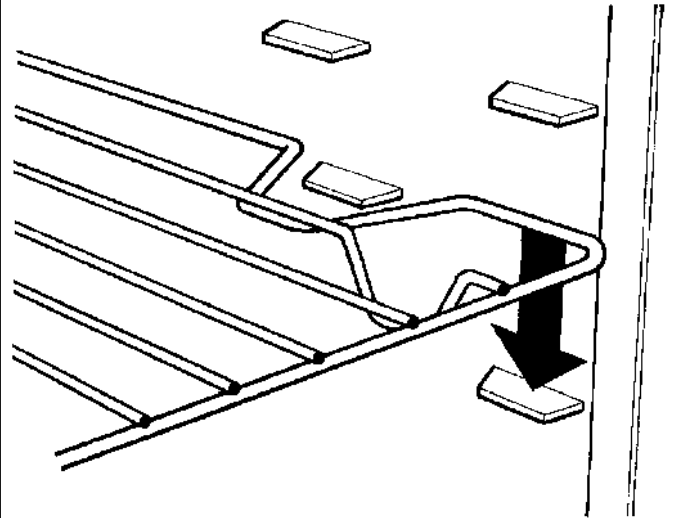

DESN 512404

Removing the shelves for cast iron, roasting, baking and simmering ovens

Fig. 7.3

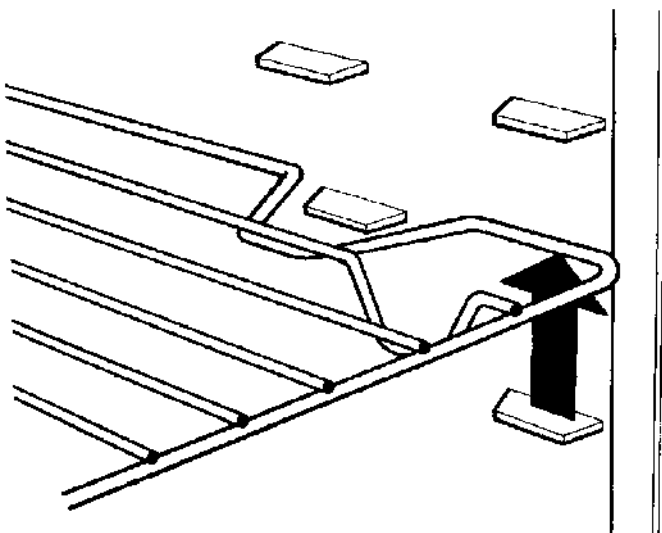

DESN 512405

Fig. 7.4

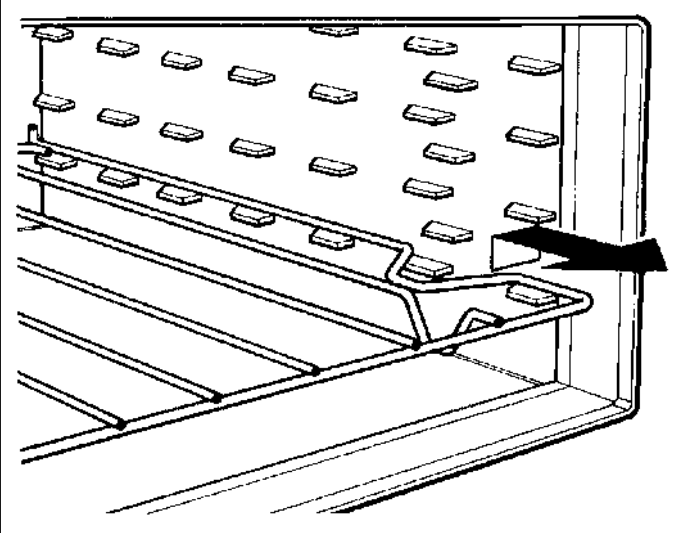

DESN 512406

CAUTION:
This unit is heavy, proper equipment and adequate manpower must be used to remove the oven doors.

8. Fitting and removing the oven doors

Fitting the Doors

Fig. 8.1

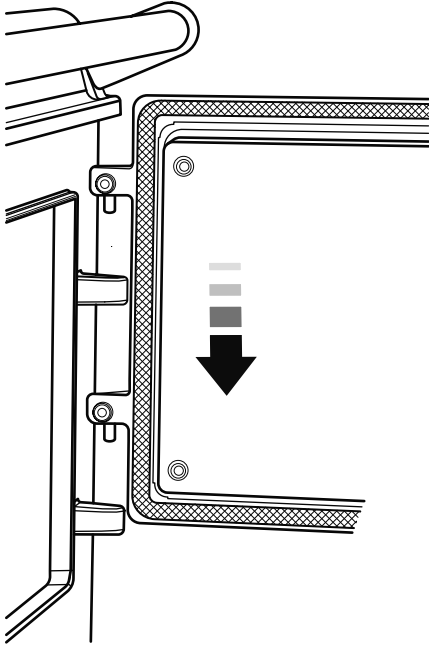

DESN 517491

Fig. 8.2

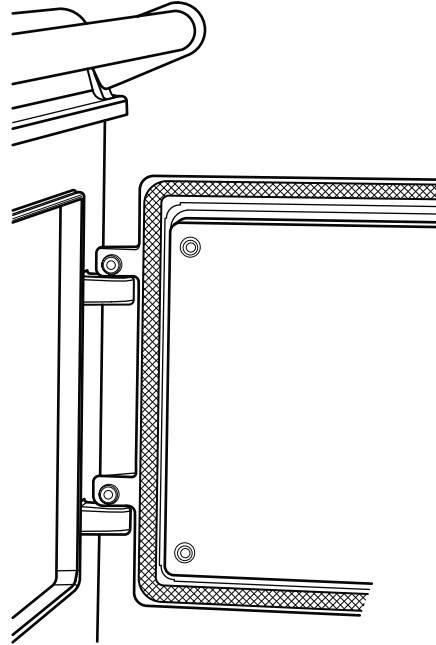

DESN 517489

Removing the Doors

Fig. 8.3

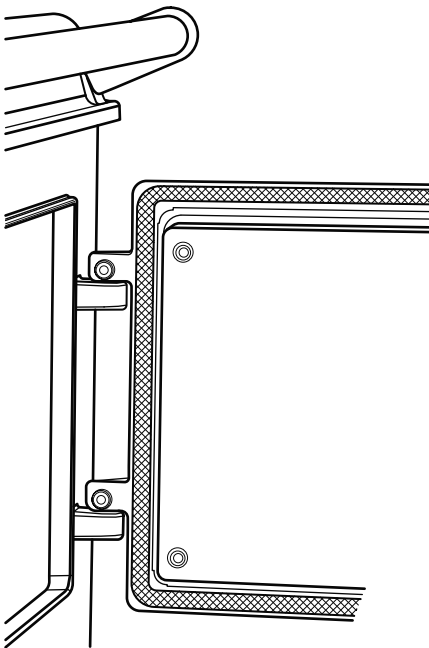

DESN 517489

Fig. 8.4

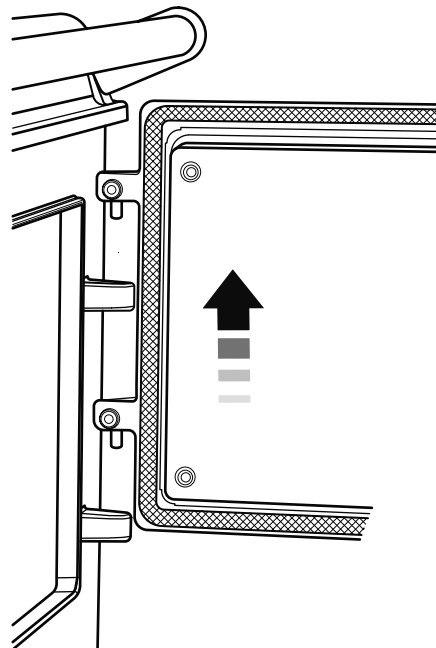

DESN 517490

9. Cooking on your AGA

As AGA ovens cook by radiated heat from the castings, rather than just hot air, exact temperature conversions are not possible. Look in the AGA cookbook for a recipe. The table below gives a quick guide to using your oven. Remember that oven shelf positions are counted from the top down.

| Oven Temperature: High | Roasting oven |
|---|--|
| Recommended shelf positions | Food |
| Top | Grilling |
| 2nd runner | Scones, Small Pastries, Grilling |
| 3rd runner | Bread Rolls, Yorkshire Puddings |
| 4th runner | Roasts, Poultry |
| Oven grid shelf on base of oven | Bread loaves, Pies, Roast Vegetables, Shallow Frying |
| Directly on base of oven | Quiches, Pies, Pizza |
| NOTE: Baking under 45 minutes - place cakes or biscuits on grid shelf on base of the oven and place cold plain shelf on runner directly above to reduce top heat | |

| Oven Temperature: Moderate | Roasting Oven, Baking Oven, Simmering Oven |
|---------------------------------|--|
| Recommended shelf positions | Food |
| Towards Top | Whisked Sponges, Some Biscuits, Small cakes |
| Middle | Fish, Soufflés, Sheppard's Pie, Cottage Pie, Lasagne |
| 4th runner | Traybakes, Shortbread, Some Biscuits |
| Oven grid shelf on base of oven | Victoria sandwich cake, Cheesecake |

| Oven Temperature: Moderate | Roasting Oven, Baking Oven, Simmering Oven |
|---|---|
| Recommended shelf positions | Food |
| Bring up to temperature on AGA Hotplate or Roasting oven, then transfer to Simmering oven | Casseroles, Stock, Soup, Milk Puddings and similar dishes |
| Dry out on grid shelf on base of oven | Meringues |
| Cook on oven grid shelf placed on base of oven | Rich Fruit Cake (4-15 hours depending on the size) |

Your AGA has a high setting which will provide a higher temperature and allow for

- faster grilling e.g. toast, breakfast
- cooking larger volumes of food, especially baking









TIPS

If food is browning too quickly slide the cold plain shelf above the food to reduce the top heat. For perfect results when baking, turn trays towards the end of cooking.

WARNING:

Accessible parts may become hot during use. To avoid burns and scalds children should be kept away.

10. Cleaning & Caring

-  **REMEMBER: be careful of the hot appliance.**
-  **For most cleaning it is best when the appliance is turned off.**
-  **DO NOT use a steam cleaner to clean this cooker.**
-  **DO NOT use abrasive pads, caustic cleaners, oven cleaners or metal scrapers to clean the surfaces of the enamel.**
-  **IMPORTANT: AGA recommend Vitreous Enamel Association approved cleaners for cleaning the vitreous enamelled surfaces of this product.**
-  **When cleaning use as little water as possible.**
-  **DO NOT immerse the doors in water as they are packed with insulating material, which will be damaged by excessive moisture.**
-  **DO NOT put oven doors or resting plates in a dishwasher.**

All that is usually needed to keep the vitreous enamelled surfaces of your cooker bright and clean is a daily rub over with a damp, soapy cloth followed immediately with a clean, dry cloth to avoid streaks.

Ovens and Hotplates - are made from cast iron and keep themselves clean. They are very durable, but will rust if surface moisture is left on them. Remember to always switch the ovens on, to dry them out after cleaning.

Heating up the ovens periodically will help burn off any cooking deposits to aid cleaning within the ovens.

To season the ovens, a light vegetable spray oil (corn oil is best) is recommended. Any stubborn stains can be removed with the wire brush supplied.

Enamelled cast iron The easiest way to clean the AGA top plate and front plate is to mop up spills as they happen. VEA approved AGA Enamel Cleaner can be purchased from www.agacookshop.co.uk.

Baked on food is more difficult to clean but can usually be removed with proprietary vitreous enamel cleaners or mild cream cleaners using a cloth, or if necessary, a nylon scouring pad and can be purchased from www.agacookshop.co.uk.

If milk or fruit juice, or anything containing acid is spilt on the enamel, wipe off immediately.

Clean off any condensation streaks on the front plate around the oven doors or vitreous enamel maybe permanently discoloured.

Remember the top plate and the polished covers will scratch if pans or utensils are dragged across them.

The top of the insulated cover (lid) This is chrome or stainless steel and can be kept clean by wiping over with a damp cloth and polished up - the AGA E-cloths are excellent for this purpose as they are lint-free and eco-friendly. AGA stainless steel and chrome cleaner are recommended to keep the insulated cover clean and shining. These can be purchased from your local AGA Specialist.

Lining of the insulated cover (lid interior) The use of an AGA splash shield is recommended to keep the lining free of fat splashes, (obtainable from your AGA Specialist or on-line at www.agacookshop.co.uk).

If the lining is marked it is best cleaned when the hotplate is cold. It can be cleaned with hot soapy water and/or a cream cleanser. If badly marked then a soap impregnated pad can be used - this should be used in a circular motion.

The first few times a soap impregnated pad is used you will see the circular marks, these will become reduced and the surface of the lining becomes shinier each time when used. Do not use excessive water and make sure the lining is dry before closing the cover.

Oven door linings The linings can be cleaned with hot soapy water, a cream cleanser or soap impregnated pad. To deep clean the lining place a towel on the work surface and carefully lift off the oven door (doors are heavy) and place it enamel side down on the towel padding. Clean with a soap impregnated pad to remove stubborn marks. Dry off before replacing on their hinges.

Enamelled roasting tins Those supplied with the appliance should be cleaned in hot soapy water, soaking if necessary. A nylon scouring pad can also be used. They may also be cleaned in the dishwasher, but with constant use, the enamelled finish will become dull in appearance.

Induction Hob The easiest way to clean the ceramic top on the AGA Induction hob is to mop up spills as soon as they happen. It maybe useful to keep a damp cloth handy to do this. The ceramic surface should then be cleaned with a proprietary cleaner such as Hob Brite.

-  **DO NOT USE HOB BRITE ON ENAMELLED SURFACES.**

11. Installation instructions

WARNING!

Please read the Warning, Cautionary notes at the start of this section. If the information contained within these instructions is not followed, property damage or personal injury may occur.

DO NOT store or use gasoline or other flammable vapors and liquids in the vicinity of this or any other appliance.

Installation and service must be performed by a qualified installer or service agency.

WARNING! This appliance must be installed with an appropriate device that will allow permanent disconnection of the Live and Neutral conductors. During Installation or disconnection prior to any electrical work, the appliance must be permanently disconnected from the Supply (Live) and Neutral Conductors.

CAUTION: THIS UNIT IS HEAVY, PROPER EQUIPMENT AND ADEQUATE MANPOWER MUST BE USED IN MOVING THE RANGE TO AVOID DAMAGE TO THE UNIT OR THE FLOOR.

REMEMBER, when replacing a part on this appliance, use only spare parts that you can be assured conform to the safety and performance specification that we require.

DO NOT use reconditioned or copy parts that have not been clearly authorised by AGA.

**PLEASE READ THESE INSTRUCTIONS BEFORE USING THIS APPLIANCE
AND KEEP IN A SAFE PLACE FOR FUTURE REFERENCE.**

12. Installation requirements

Consumer protection

As a responsible manufacturer, we take care to make sure that our products are designed and constructed to meet the required safety standards when properly installed and used.

WARNING - ELECTRIC SHOCK HAZARD

It is the customer's responsibility to contact a qualified electrical installer to make sure the electrical installation is adequate and in conformance with the regulations.

Take special care when cutting holes in walls or floor. Electrical wires may be behind the wall or floor covering and could cause an electrical shock if you touch them.

Locate any electrical circuits that could be affected by the installation of this product and disconnect power circuit.

WARNING: THIS APPLIANCE MUST BE EARTHED.

DO NOT use an extension lead with this appliance.

The appliance is designed for the voltage stated on the data plate.

Recommended but not mandatory to fit an individual Residual Current Device (RCD) to the cooker supply circuit.

Hand this Manual to the User for retention and instruct in the safe operation of the appliance.

Delivery requirements

- The AGA R7 arrives on 1 pallet
- The AGA R7 with Hotcupboard arrives on 2 pallets.

There must be access to the kitchen to manipulate a foot print of 39 $\frac{5}{16}$ " (1005mm) x 29 $\frac{1}{8}$ " (740mm). A wooden template (skate with castor wheels) of dimensions 39 $\frac{5}{16}$ " (1005mm) x 29 $\frac{1}{8}$ " (740mm) could be used to check if the AGA eR7 fully built appliance is able to fit through the property grounds and doors into its installation position in the kitchen. It must also be considered that the height of the appliance is 37 $\frac{5}{8}$ " (960mm) off pallet and 43 $\frac{3}{8}$ " (1100mm) on the pallet, so high level obstacles/restrictions must not be overlooked.

If this skate/template can be manipulated through the property grounds and doors into position, then the AGA can be installed as intended with no re-work.

13. Location

Refer to **Fig. 14.1**.

It is recommended that any soft material flooring is removed from where the AGA will be installed.

It is essential that the base or hearth on which both range and/or module stands should be level and capable of supporting the total weight of one or both units.

The front plinth cover is removable and must not be obstructed by flooring or tiles. If necessary the range must be raised by the thickness of the tiles to ensure the plinth can be removed.

Any adjacent walls that project above the height of the hob must be of heat resistant material.

The side wall above the hob shall be greater than 3" (75 mm) from the range.

Surfaces over the top of the range must not be closer than 30" (760 mm).

The vent slots in the back of the top plate (or shroud) must not be obstructed.

NOTE: It is advisable that the supply cable is routed away from any hot surfaces i.e. hot water/flue pipes.

In the interest of safety, due consideration must be given to the protection of the electric cable to the range.

If a supply cord is damaged it must be replaced by the manufacturer, its service agent or similarly qualified persons in order to avoid a hazard.

The appliance is designed for the voltage stated on the rating plate, which is situated in the centre vent slot near the base of the front plate.

⚠ DO NOT install the range behind a decorative door in order to avoid overheating.

The complete range is floor-mounted and the space in which the appliance is to be fitted must have the following minimum dimensions:-

A minimum clearance of 2 ¼" (60 mm) is required above the raised insulating cover handle.

Overhead Cabinets

⚠ To eliminate the risk of burns or fires by reaching over hot surface units, cabinet storage space located above the surface units should be avoided.

Minimum Clearance to Combustibles

A gap of at least ½" must be observed between the rear of the top plate, and the wall behind the appliance. If the rear wall is of combustible material there must be a gap of 1" (25mm).

Range Hoods

It is recommended that this AGA is fitted with a range hood. The AGA venting system is located on top of the AGA between the two hotplates, and is designed for venting the moisture from the ovens. The cooker hood should be positioned not less than the minimum height as recommended by the manufacturer, from the top of the AGA.

Side Clearances

A ⅛" (3 mm) gap is required each side between the range top plate and adjoining work surfaces that may be fitted, this is to allow for the safe removal of the top plate should this be required at a later date.

Where ranges are fitted against side walls a 4 ⅞" (116 mm) clearance is required on the right and left hand side for oven doors access.

If the AGA is to be installed in a brick recess, then the minimum clearance should be increased by at least ⅜" (10 mm), to allow for the walls not being square.

In addition, a minimum clearance of 39 ⅜" (1000 mm) must be available at the front of the range to enable the range to be serviced.

Tiling

When the range is to stand in a recess or against a wall which is to be tiled, in no circumstances should the tiles overlap the range top plate, access to remove the top plate must be allowed for servicing at a later date.

Rear Wall

A gap of at least ⅜" (10 mm) must be observed from the rear of the top plate, and the wall behind the appliance.

This appliance runs continuously, please take note of these **IMPORTANT** instructions:

Combustible Walls

Houses constructed of combustible materials (such as all-timber or stud wall partitions and batoned plasterboarded walls) require special wall heat protection features.

Non-combustible walls behind a range must be of at least 1" (25 mm) thick insulation board (Monolux or equivalent), up to hotplate level.

⚠ NOTE: Ensure electric cabling or plastic services do not pass within or on the outside of the wall, behind or directly above the range.

This type of material can age prematurely when exposed to continuous higher ambient temperature.

14. Clearances

Fig. 14.1

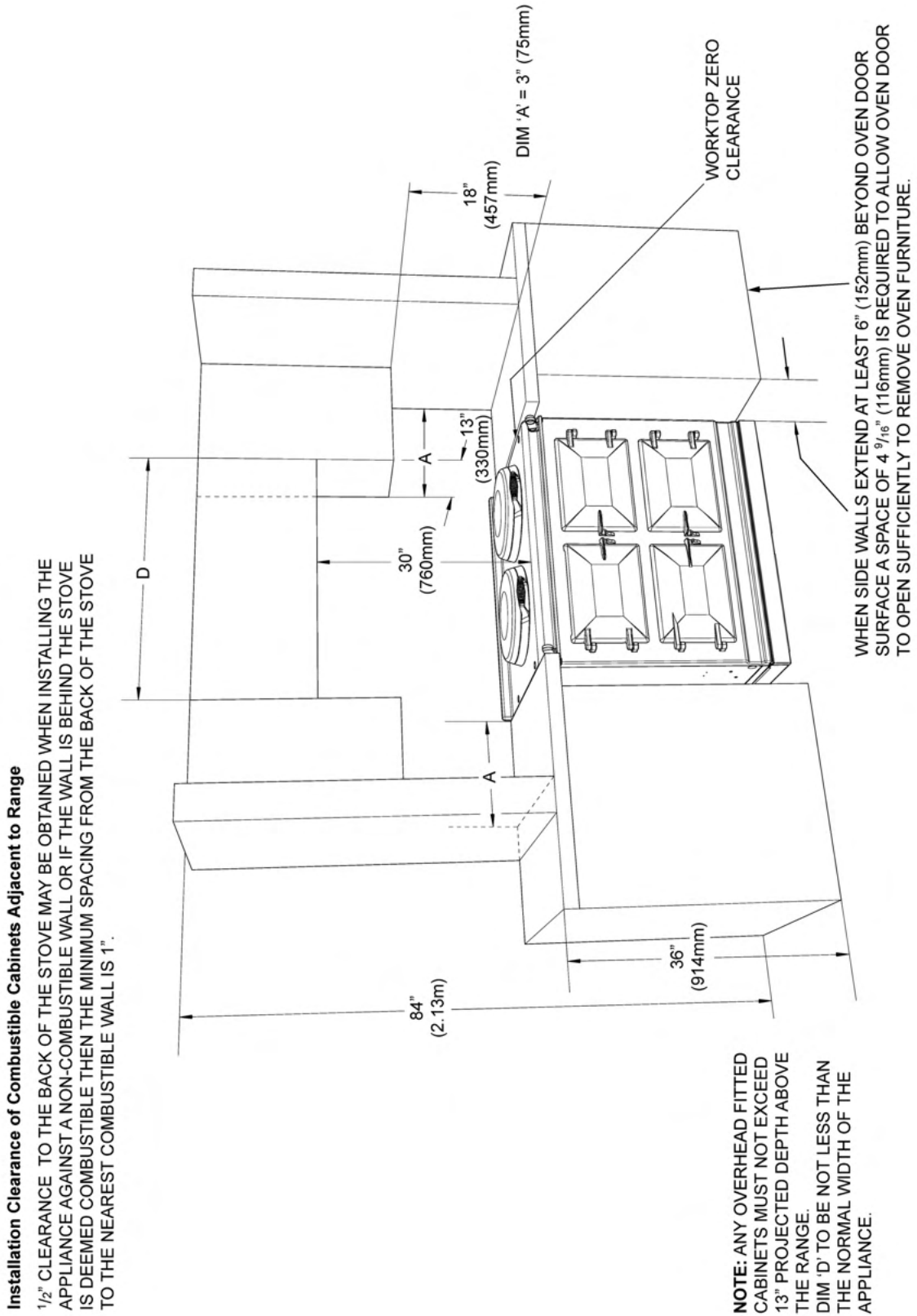

DESN 516298

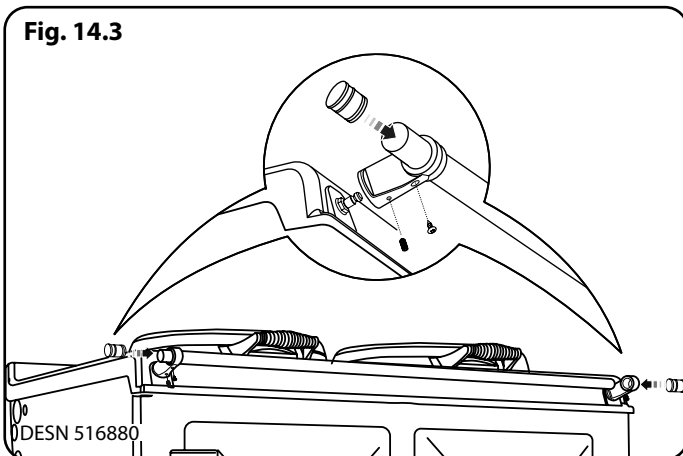
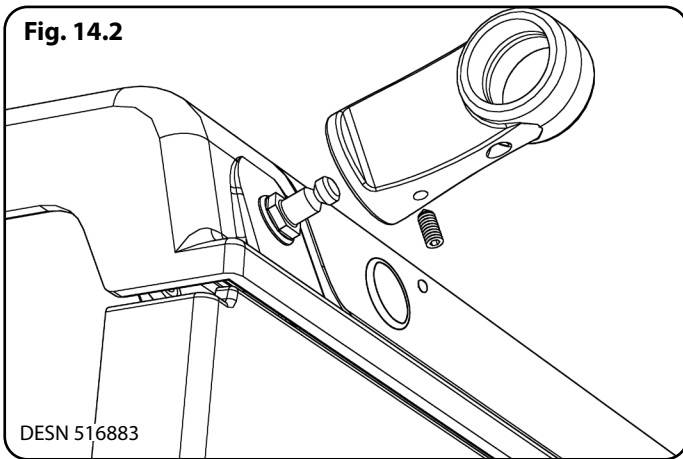

Fitting the Handrail

1. Fit the handrail bracket over the fixing stud located on the top plate. Lock into position by tightening the grub screw nearest the appliance **Fig. 14.2**.
2. Slide the handrail through the handrail brackets **Fig. 14.3**.
3. Once the handrail assembly is located squarely, lock the handrail in position by winding in the grub screws on the underside of each handrail bracket.
4. Once the handrails are locked in position, fit the handrail endcaps. The endcaps should be carefully pushed into place until they sit flush with the outside face of each bracket (a light smear of lubricant such as, hand or dish soap on the end cap 'O' rings may ease fitment **Fig. 14.3**).
5. Finally, fit the plinth fascia to the magnets on the front of the plinth. Make sure that the plinth fascia is centrally located and does not overhang the range.
6. Commission the AGA R7, as stated in the relevant Installation Instructions and carry out functional test on each of the features of the AGA R7.
7. Attach warning hanger (EGLL516660) located in literature pack, to AGA R7 handrail when installation is complete. Advise customer to remove and read warning label.
8. Hand this Guide to the user for retention and instruct in the safe operation of the appliance.
9. Also advise the user that, for continued efficient and safe operation of the appliance, servicing is carried out at intervals recommended by the AGA distributor.

AGA R7 100

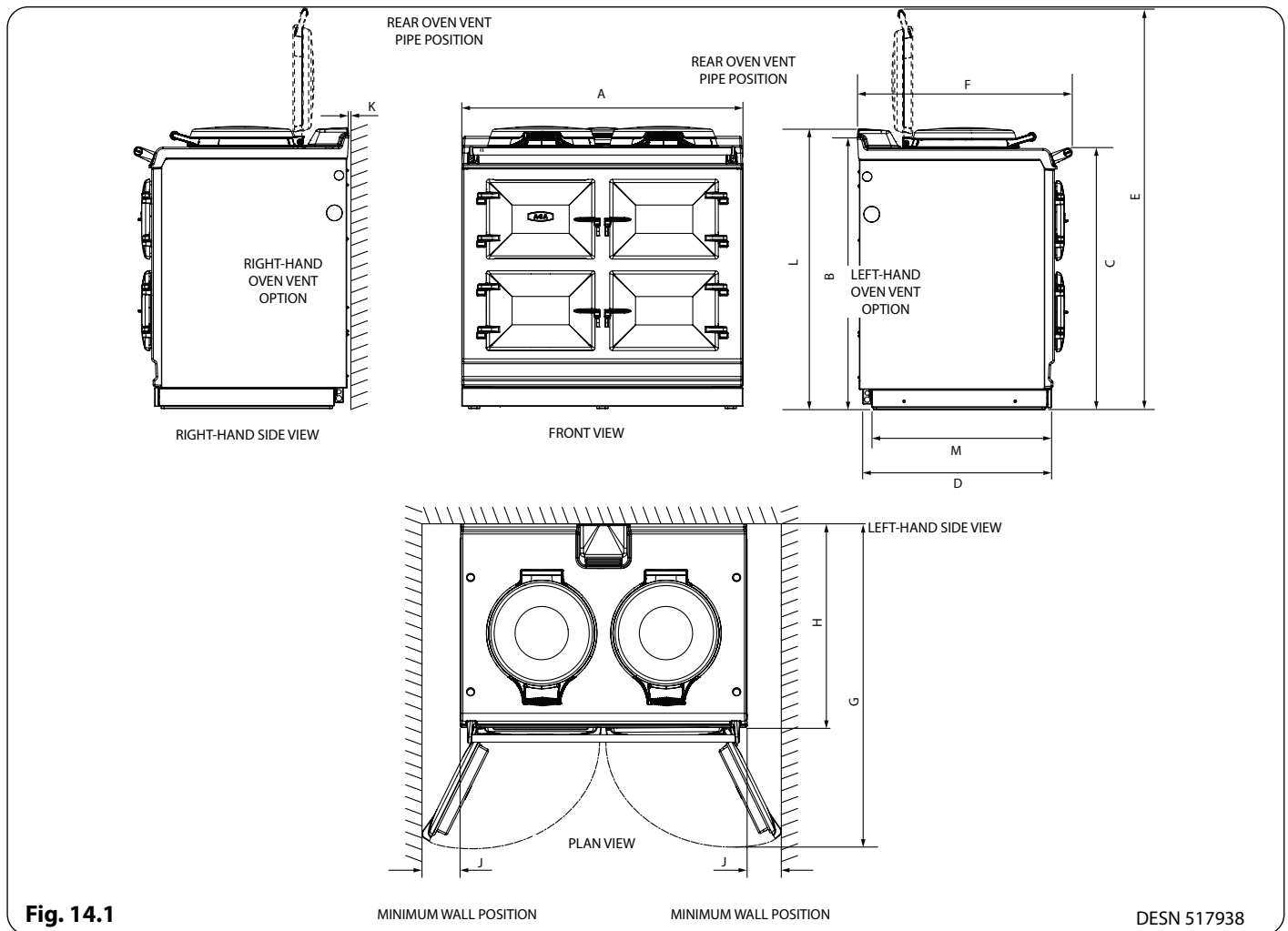

Fig. 14.1

DESN 517938

| | A | B | C | D | E | F | G | H | J | K | L | M |
|----|----------|----------|-----------|---------|---------|---------|----------|----------|---------|------|---------|---------|
| mm | 58 3/16" | 37 7/16" | 35 15/16" | 26 3/4" | 54 5/8" | 29 7/8" | 45 1/16" | 27 7/16" | 4 9/16" | 3/8" | 38 3/4" | 24 3/4" |

Cooker Dimensions

When surveying for a cooker installation the actual clearance required for the 'body' of the appliance should be increased by 3/8" (10mm) beyond the figures quoted above. This allows safe margin to take into account the natural dimensional variations found in major castings. In particular the width across the appliance recess could be critical.

APPLIANCE WEIGHT (Excludes Packaging)

Model: AGA R7 - 979 lb

AGA R7 150

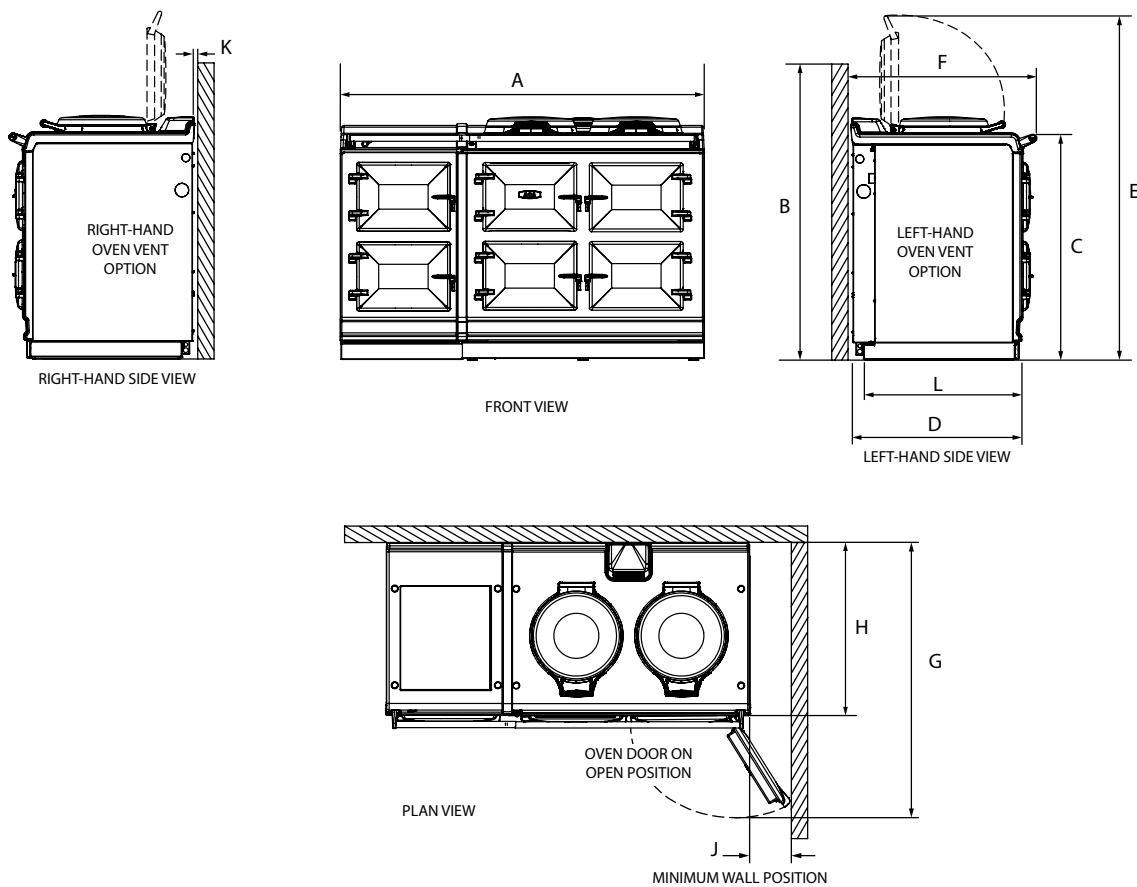

Fig. 14.2

DESN 517939

| | A | B | C | D | E | F | G | H | J | K | L |
|----|----------|----------|-----------|---------|---------|---------|----------|----------|---------|------|---------|
| mm | 58 3/16" | 37 7/16" | 35 15/16" | 26 3/4" | 54 5/8" | 29 7/8" | 45 1/16" | 27 7/16" | 4 9/16" | 3/8" | 24 3/4" |

Cooker Dimensions

When surveying for a cooker installation the actual clearance required for the 'body' of the appliance should be increased by 3/8" (10mm) beyond the figures quoted above. This allows safe margin to take into account the natural dimensional variations found in major castings. In particular the width across the appliance recess could be critical.

APPLIANCE WEIGHT (Excludes Packaging)

Model: AGA R7 - 979 lb

Hotcupboard - 243 lb

15. Power Supply connections

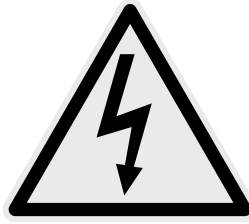

Electric Shock Hazard



The rating plate is located behind the removable plinth.

If the supply cord is damaged, it must be replaced by the manufacturer, its service agent or similarly qualified person to avoid a hazard.

Electrical Grounding is required on this appliance.

DO NOT connect to the electrical supply until the appliance is permanently grounded.

This appliance must be connected to a grounded, metallic, permanent supply. Or a grounding connector should be connected to the grounding terminal or wire lead on the appliance.

Failure to follow these instructions could result in death or serious injury.

This range must be supplied with a 240V, 60Hz power supply and connected to an individual, properly grounded branch circuit protected by a circuit breaker. At 240V, it has a maximum load of 30 amps. Electric hook-up must be done by a licensed electrician. This unit must be installed according to regional codes, or in the absence of codes, the National Electrical Code.

- Product installation requires a separate (not shared) 240V/40 amp circuit protected by an appropriate branch circuit supply.
- The service cord on your range is fitted with a standard four (4) prong type 14-50P plug (matching receptacle 14-50R).

The method of connection to the mains electricity supply must facilitate complete electrical isolation of the appliance.

The mains connection and isolation should not be positioned above the range and must be positioned within the area defined in **Fig. 16.2**.

THIS RANGE MUST BE COMPLETELY ISOLATED FROM THE ELECTRICITY SUPPLY BEFORE SERVICING. THE RANGE IS DESIGNED FOR THE VOLTAGE STATED ON THE RATING PLATE, WHICH IS SITUATED BEHIND THE PLINTH COVER.

⚠ WARNING: THIS APPLIANCE MUST BE EARTHED.

THIS APPLIANCE IS DESIGNED FOR THE VOLTAGE STATED ON THE RATING PLATE, WHICH IS SITUATED BEHIND THE PLINTH COVER.

IF THE SUPPLY CORD IS DAMAGED, IT MUST BE REPLACED BY THE MANUFACTURER, ITS SERVICE AGENT OR SIMILARLY QUALIFIED PERSON TO AVOID A HAZARD.

AGA Hotcupboard connections

THE HOTCUPBOARD ATTACHMENT REQUIRES A INDEPENDENT SINGLE PHASE POWER SUPPLY.

⚠ WARNING: THIS APPLIANCE MUST BE EARTHED.

THIS APPLIANCE IS DESIGNED FOR THE VOLTAGE STATED ON THE RATING PLATE, WHICH IS SITUATED ON A SLIDE-OUT TRAY IN THE HOTCUPBOARD BASE PLATE ABOVE THE PLINTH.

IF THE SUPPLY CORD IS DAMAGED, IT MUST BE REPLACED BY THE MANUFACTURER, ITS SERVICE AGENT OR SIMILARLY QUALIFIED PERSON TO AVOID A HAZARD.

A 120v ~ 60 Hz, 5 amp fused electrical supply is required adjacent to the appliance (with the exception of the AGA Hotcupboard with Induction Hob model, please refer to the AGA Induction Hob model instructions for the power supply requirements). External wiring to the unit must be installed using the mains cable provided, in accordance with the current wiring regulations and any local regulations which apply.

The method of connection to the mains electricity supply must facilitate complete electrical isolation of the appliance, preferably by a fused double pole switch, having a contact separation of at least $\frac{1}{8}$ " (3mm) in both poles.

The isolator should not be positioned immediately above the hotcupboard, but must be fitted with 6ft 6 $\frac{3}{4}$ " of the appliance.

Power supply - Hotcupboard with induction hob, please refer to owners manual supplied with the appliance.

16. Mains Supply Location

Mains cable routing

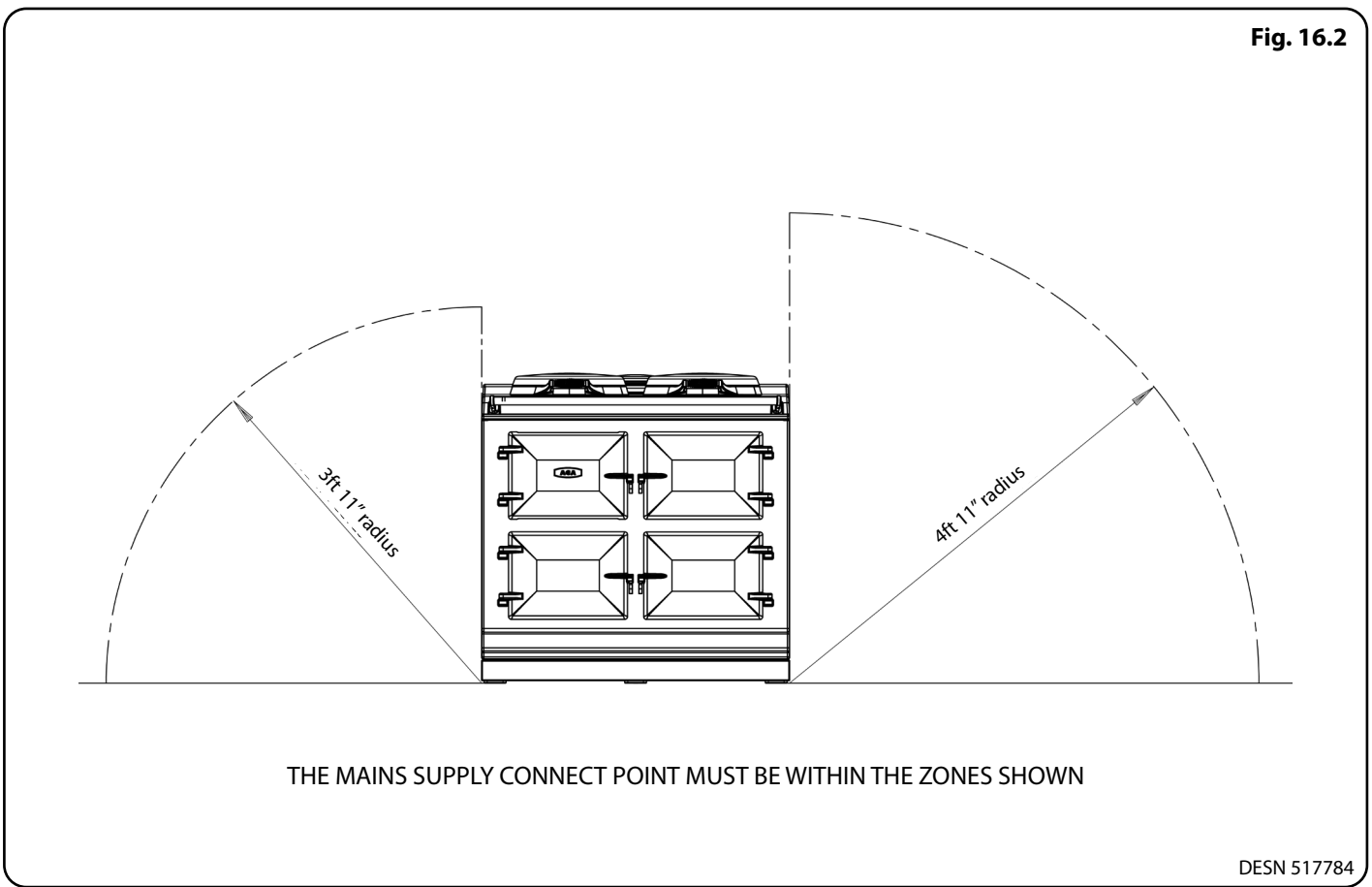
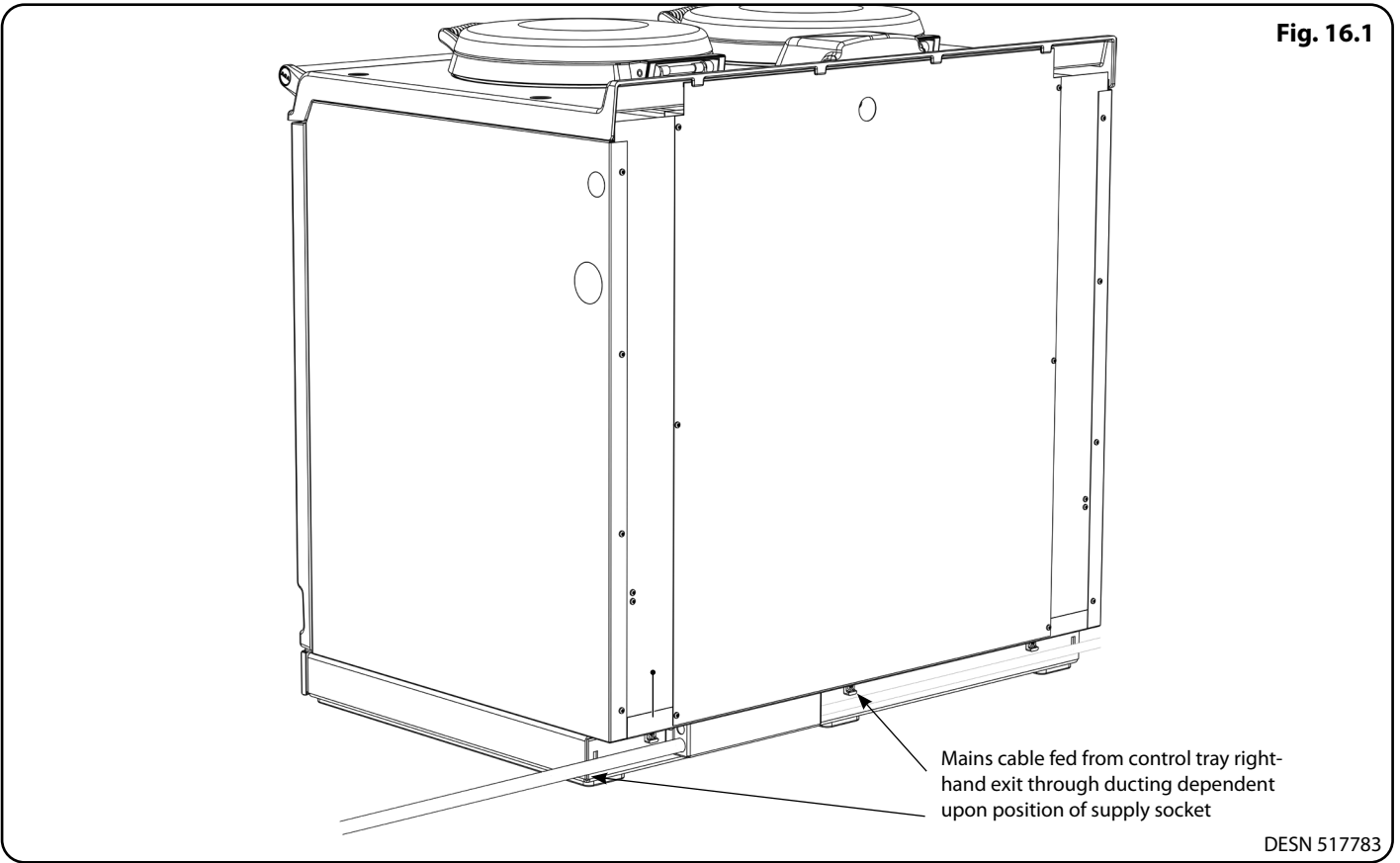

Mains cable routing- AGA Hotcupboard

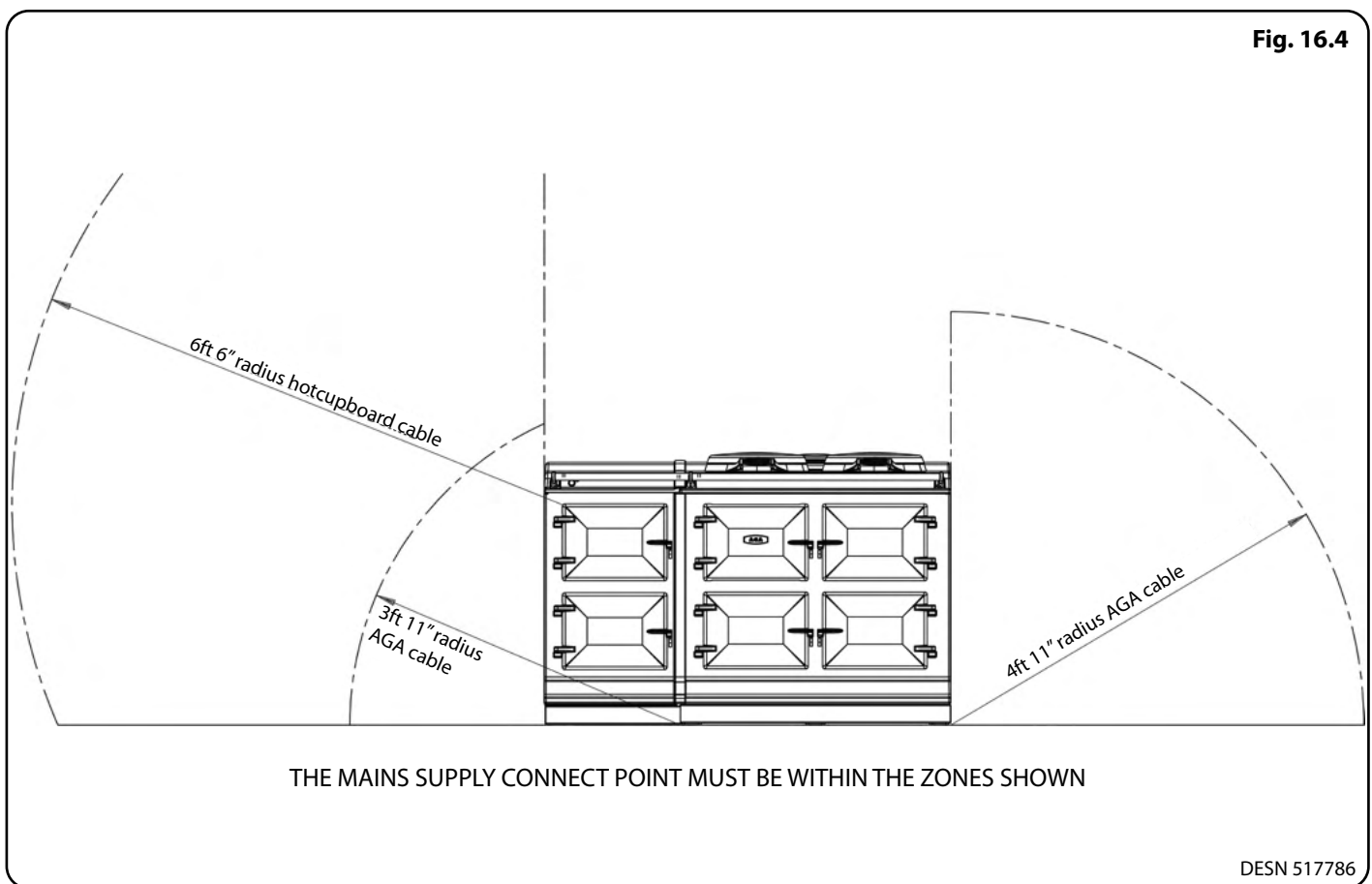
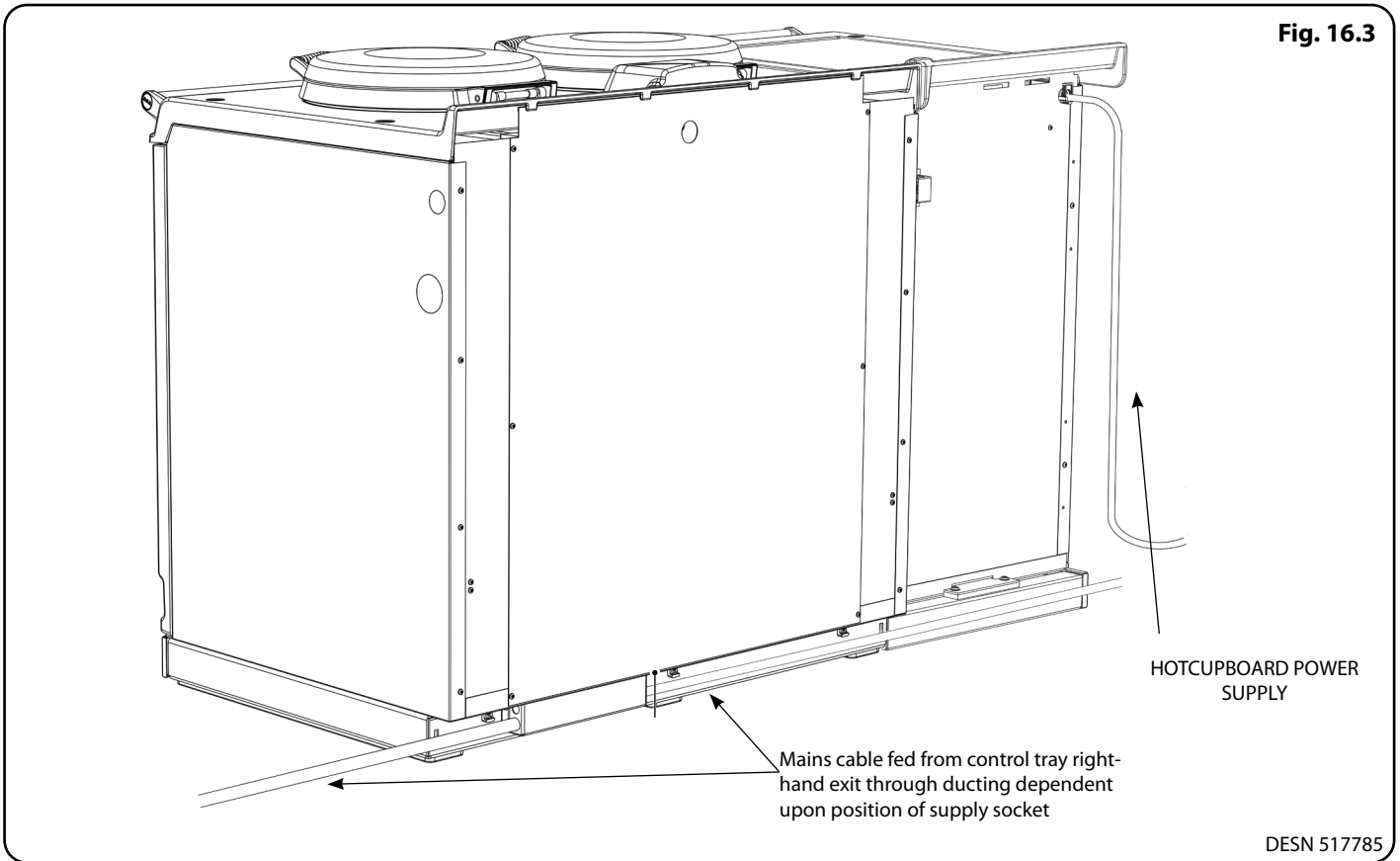

17. Hotcupboard installation

NOTE: The AGA R7 hotcupboard should arrive with the top plate in a jacked up position (**except for induction top versions which will arrive with the top fully wound down**). This is to allow the complete appliance to be slid onto its plinth when alongside the AGA R7 without the top plates clashing. The hotcupboard top plate should then be wound down to its correct height once the appliance is in its final position.

For induction top versions the top plate adjusters will need to be wound upwards before the hotcupboard can be fitted onto its plinth, in order to provide adequate clearance between the two top plates.

1. Detach hotcupboard from plinth by removing two screws and tongue bracket from plinth (**Fig. 17.1**), slide hotcupboard forwards and away from rear fixing bracket (**Fig. 17.2**).

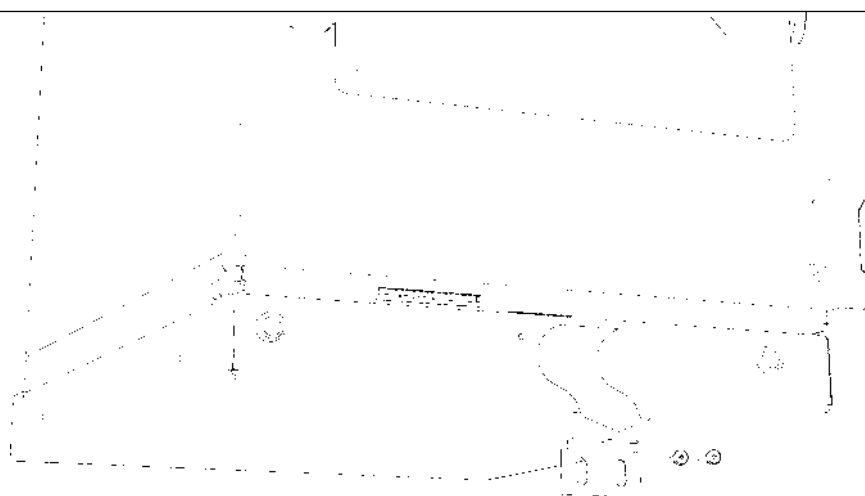

Fig. 17.1

DESN 516448

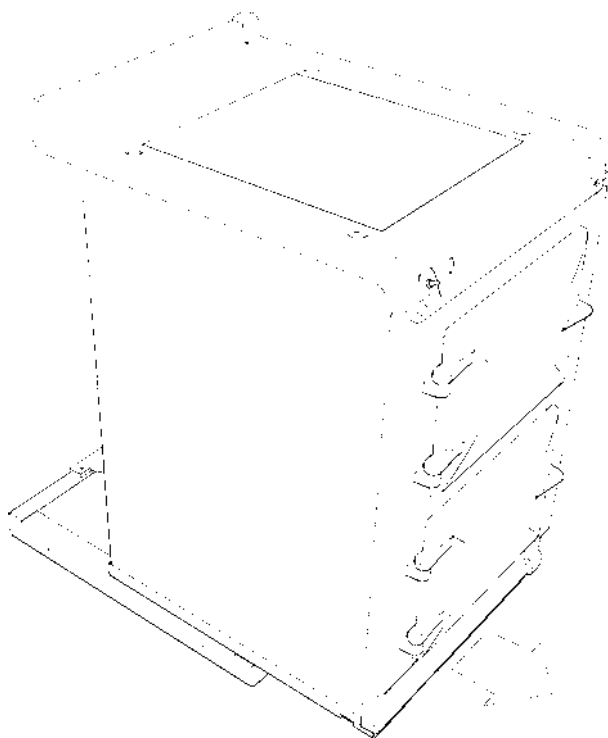
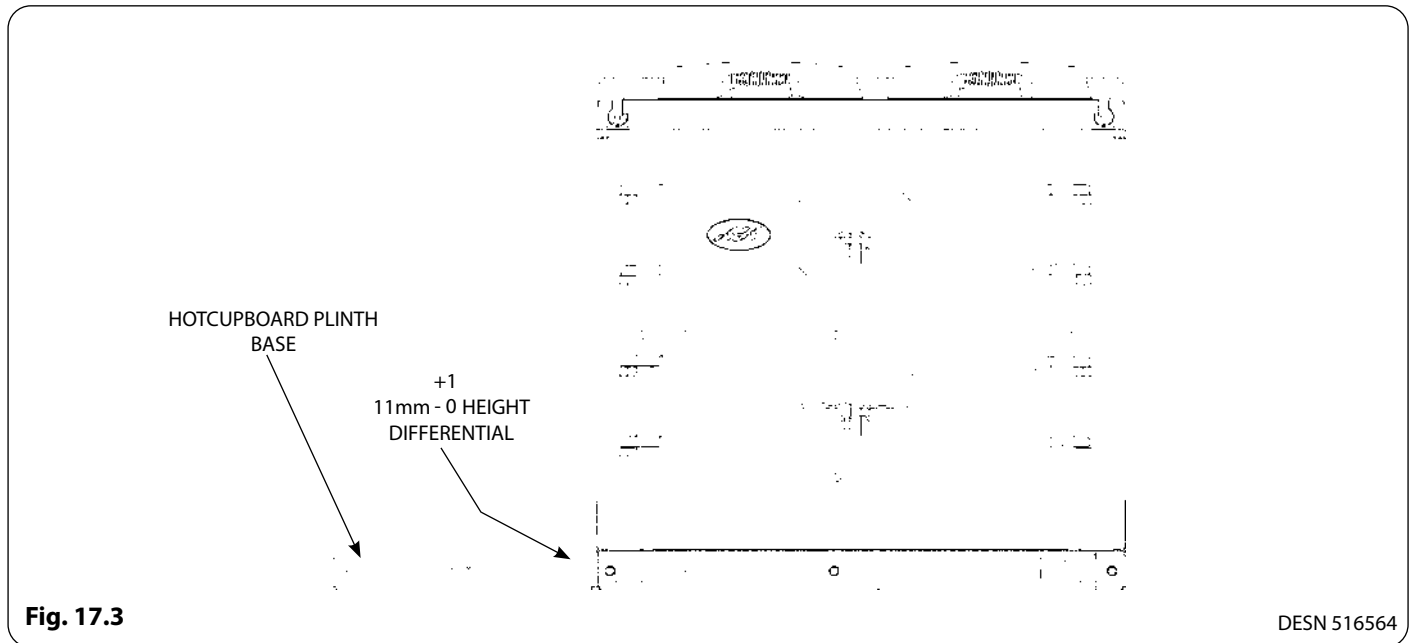

Fig. 17.2

DESN 516449

2. Position the plinth alongside the AGA R7 leaving no gap between the two plinths (**Fig. 17.3**).

Check with a spirit level that the plinth level is correct, and also check height differential between the hotcupboard plinth and R7 100 plinth is correct $\frac{3}{16}$ " (11mm). If necessary, use shims in each corner to level the plinth.



3. Attach hotcupboard plinth to the AGA R7 plinth using M6 screws and washers provided (**Fig. 17.4**).

Attach locking screw and jacking screw into plinth. Make sure at this stage that the jacking screw does not protrude beyond outer face of plinth. Ensure locking screw is located into AGA R7 100 plinth but not fully tightened. A gap of approximately $\frac{3}{8}$ " (3mm) should be present between the plinths apart from at the very front where the hotcupboard spacer plate should be touching the AGA R7 100 plinth.

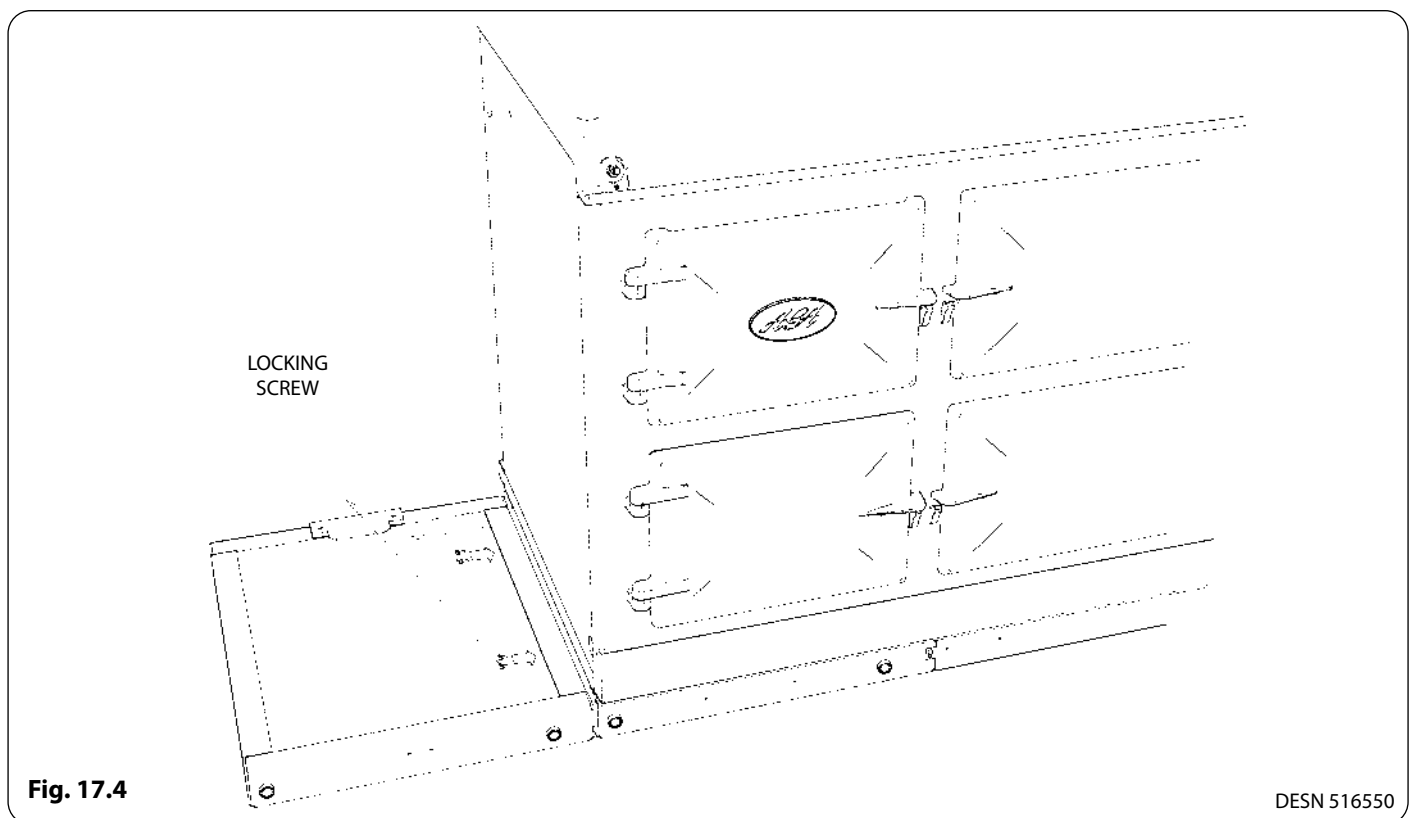

4. Run a straight edge along the front of the AGA R7 100 plinth, to ensure the front face of both plinths sit squarely against the straight edge. (Fig. 17.5)

When satisfied both plinths sit squarely, jacking screws can be tightened until they just make contact with the AGA R7 100 plinth, and locking screws can now be tightened.

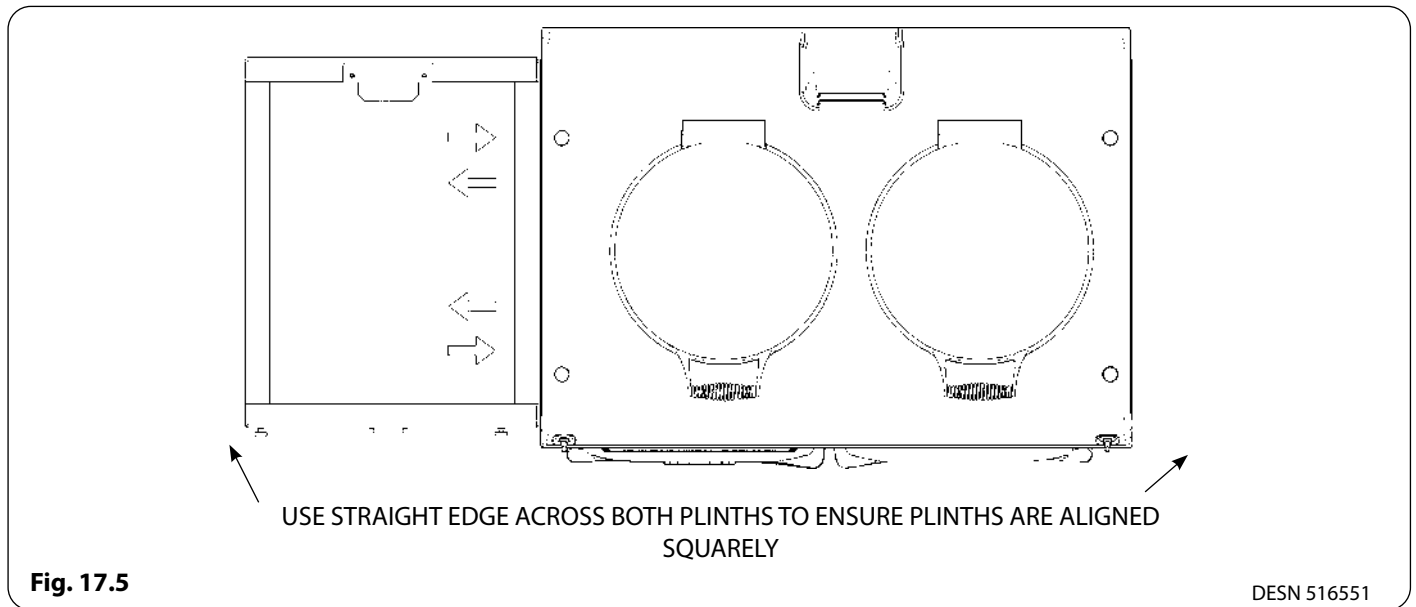

5. Front jointing bracket can now be hooked into place over the two pot magnets. This will latch the two plinths together. (Fig. 17.6)

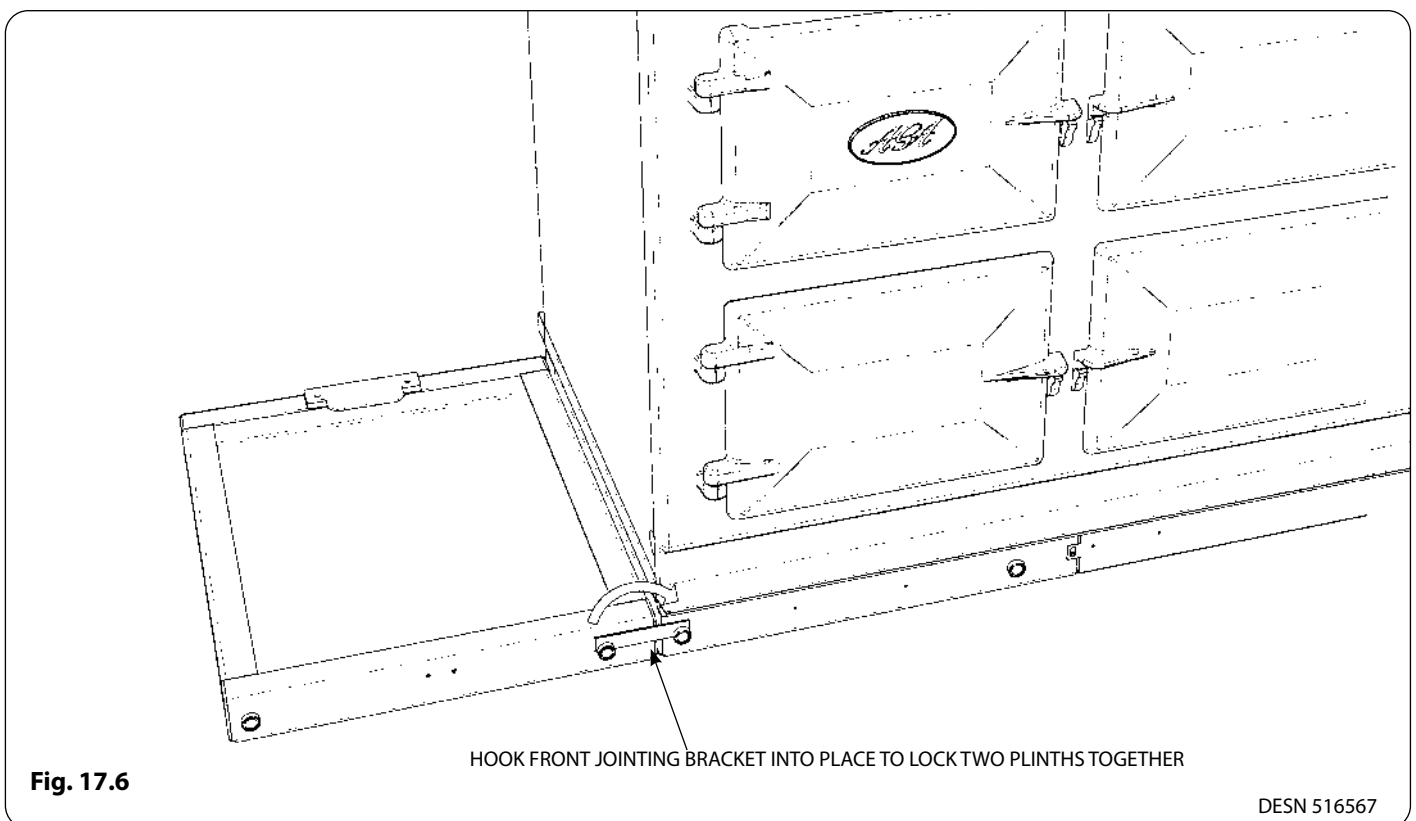

6. Slide hotcupboard onto plinth until rear tongue bracket engages fully into rear of base slot, (**Fig. 17.7**). Ensure the appliance is aligned squarely with the plinth then proceed to engage the front tongue bracket into the slot on the underside of the base plate. Once satisfied that the front tongue bracket is engaged fully lock it into place by tightening the two M6 screws fully. Ensure that the electrical cable does not come into contact with oven vent pipe from the AGA R7.

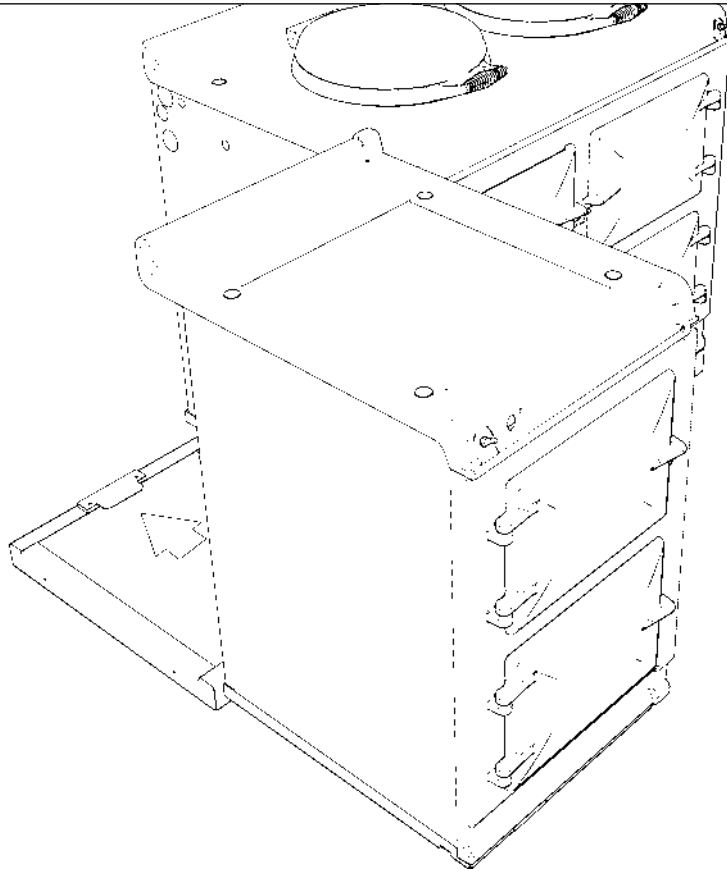

Fig. 17.7

DESN 516552

7. The hotcupboard top plate is set 5mm higher than the AGA R7 100 top plate. This is to prevent damage to the enamel during installation. Lower the top plate using the adjusters (**Fig. 17.8** and **Fig. 17.9**).

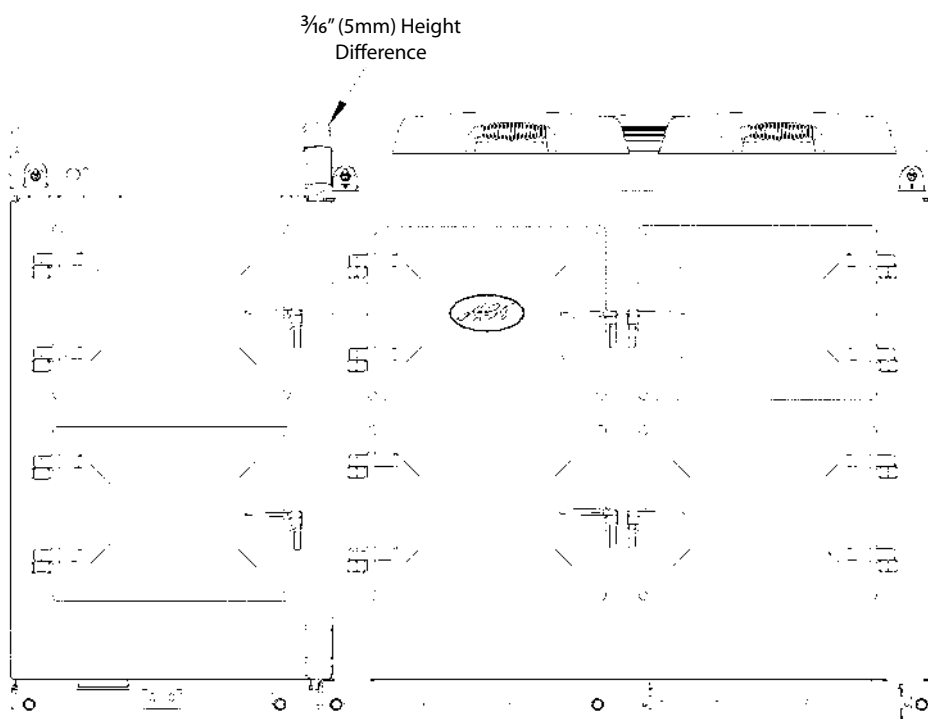

Fig. 17.8

DESN 516554

- Using the stay rod nut adjusting tool, carefully lower the top plate adjusting nuts until the top plate sits at the required height, making sure that the top sits level and matches the height of the AGA R7 100. (**Fig. 17.9**).

For servicing requirement, top plate should be removed by raising adjusters approximately $\frac{3}{16}$ " (5mm), the top plate can now be removed easily without causing damage to the enamelled surfaces.

When removing the top plate, the switch wiring harness should be disconnected from the main wiring harness at the connection point located at the front left hand side of the appliance, beneath the formex cover sheet.

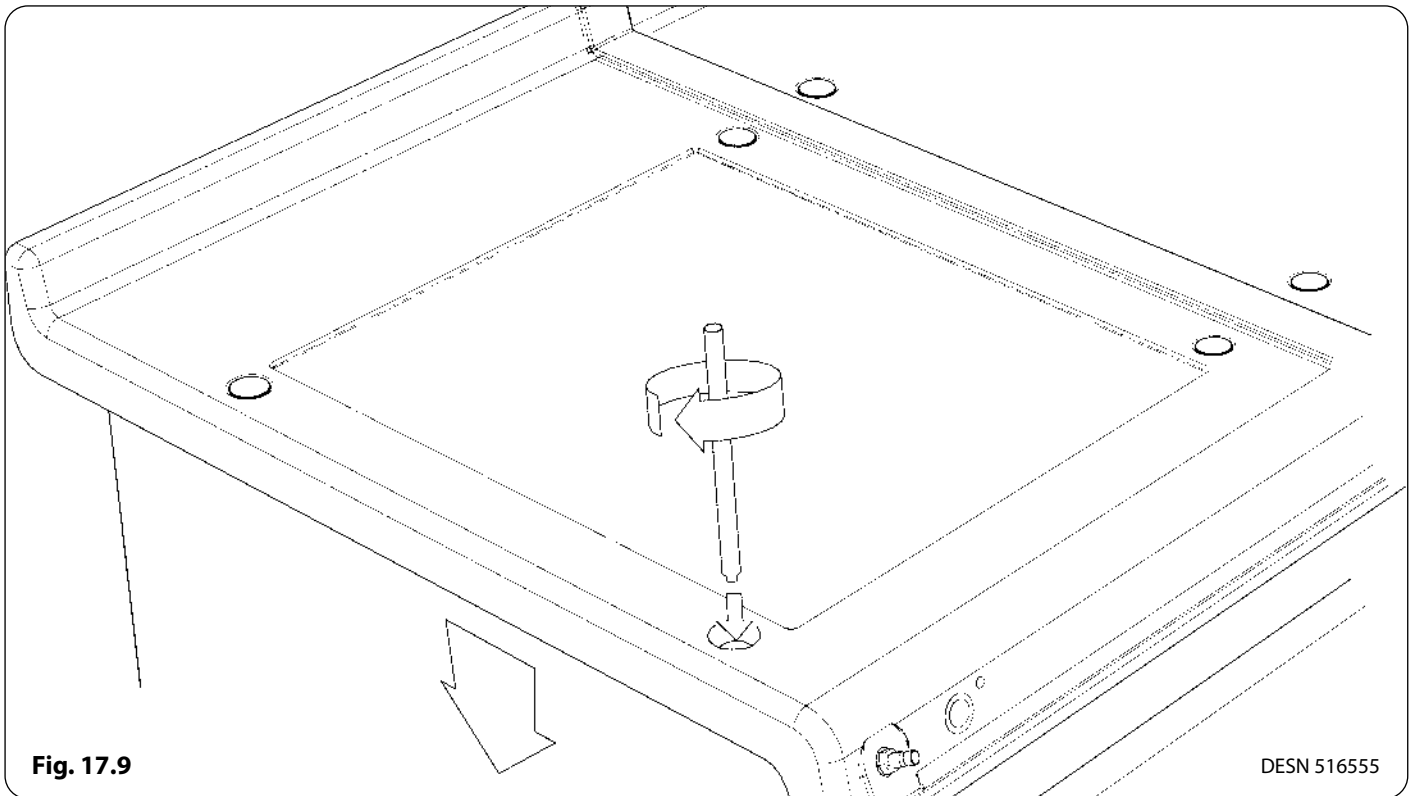

- Fit the handrail bracket over the fixing stud located on the top plate. Lock into position by tightening the grub screw nearest the appliance. (**Fig. 17.10**).

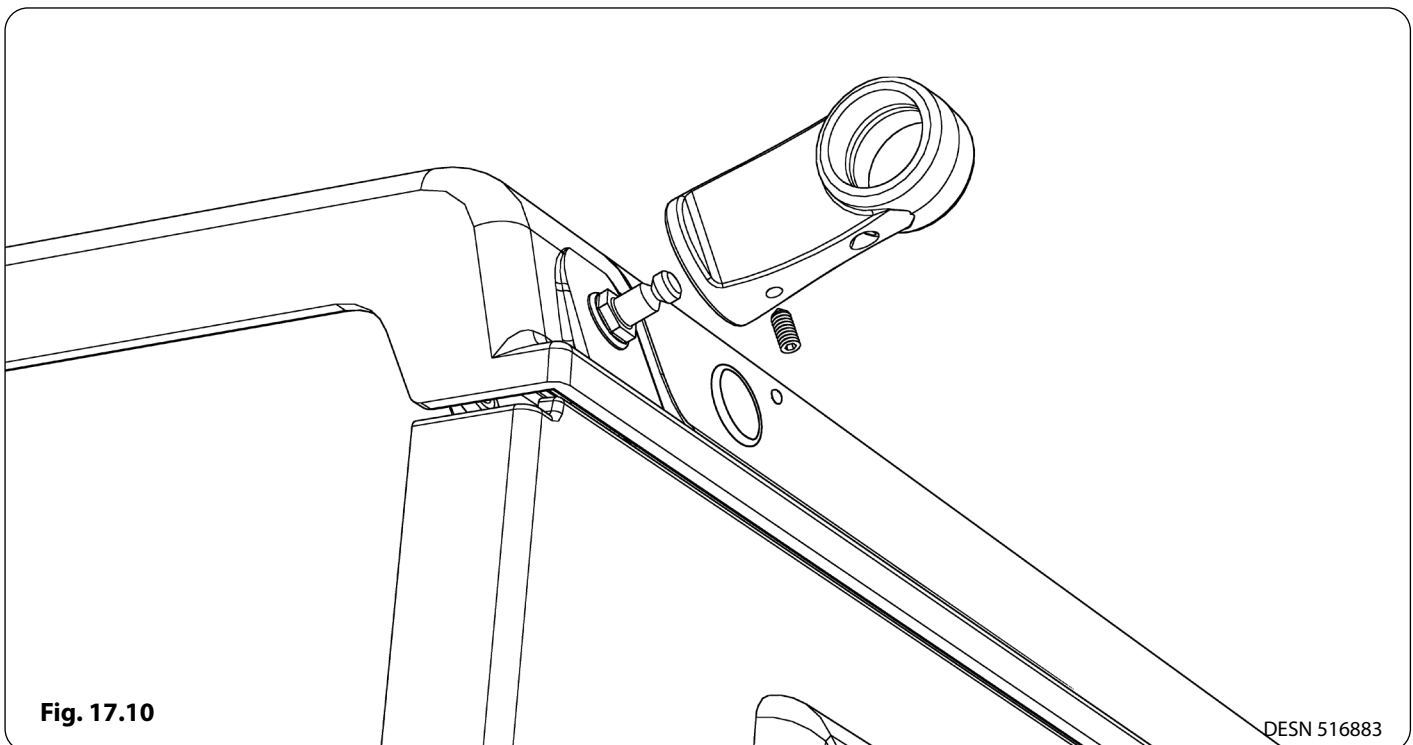

10. Next the handrail, endcaps and handrail require assembly. Slide the handrail through the handrail brackets.

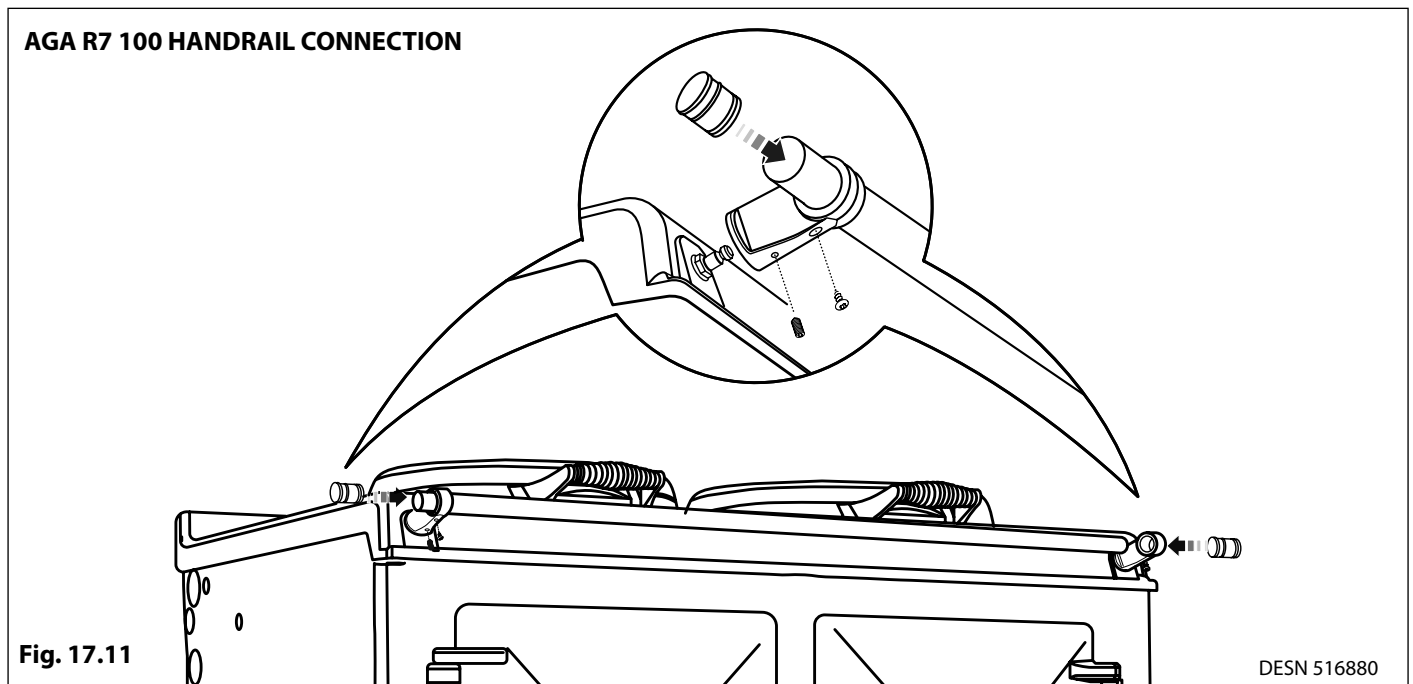

11. On 5 oven appliances, fit allthread stud into the insert located in the one end of the handrail, then feed the handrail through the bracket (ensuring that the allthread stud is protruding from the right hand side of the hotcupboard handrail) and screw the handrails together. (**Fig. 17.12**).

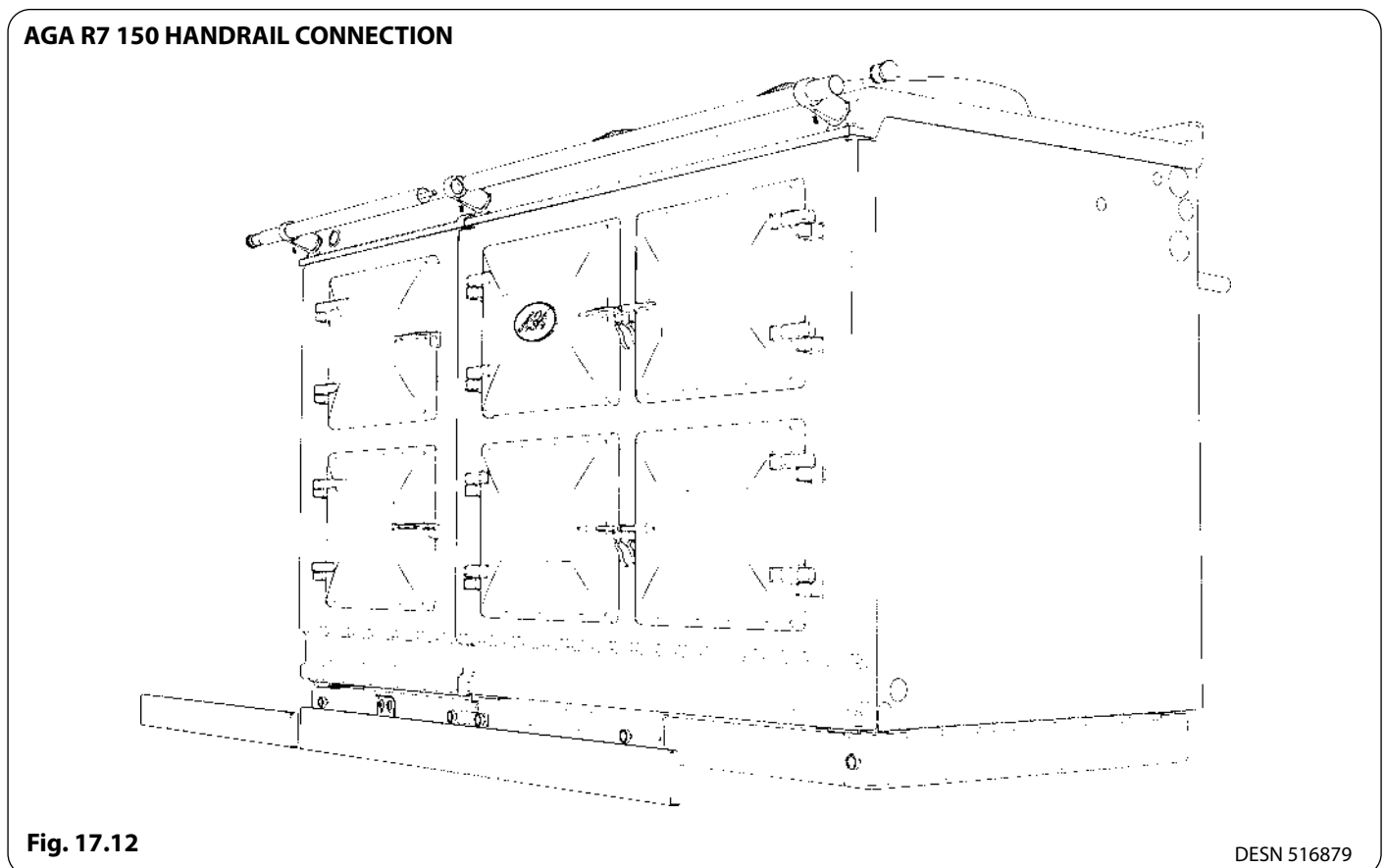

- 12.** Once the handrail assembly is located squarely, lock the handrail in position by winding in the grub screws on the underside of each handrail bracket.
- 13.** Once the handrails are locked in position, fit the handrail endcaps. The endcaps should be carefully pushed into place until they sit flush with the outside face of each bracket (a light smear of lubricant such as, washing up liquid on the end cap 'O' rings may ease fitment).
- 14.** Finally, fit the plinth fascia to the magnets on the front of the plinth, making sure that on 5 oven appliances the right hand side of the module plinth fascia sits against the left hand side of the AGA R7 100 plinth fascia leaving no gap between. Make sure that the plinth fascias are centrally located and do not overhang either appliance. (**Fig. 17.12**)

Commission the AGA R7, as stated in the relevant Installation Instructions and carry out functional test on each of the features of the AGA R7.

18. Circuit diagram

R7 Circuit diagram

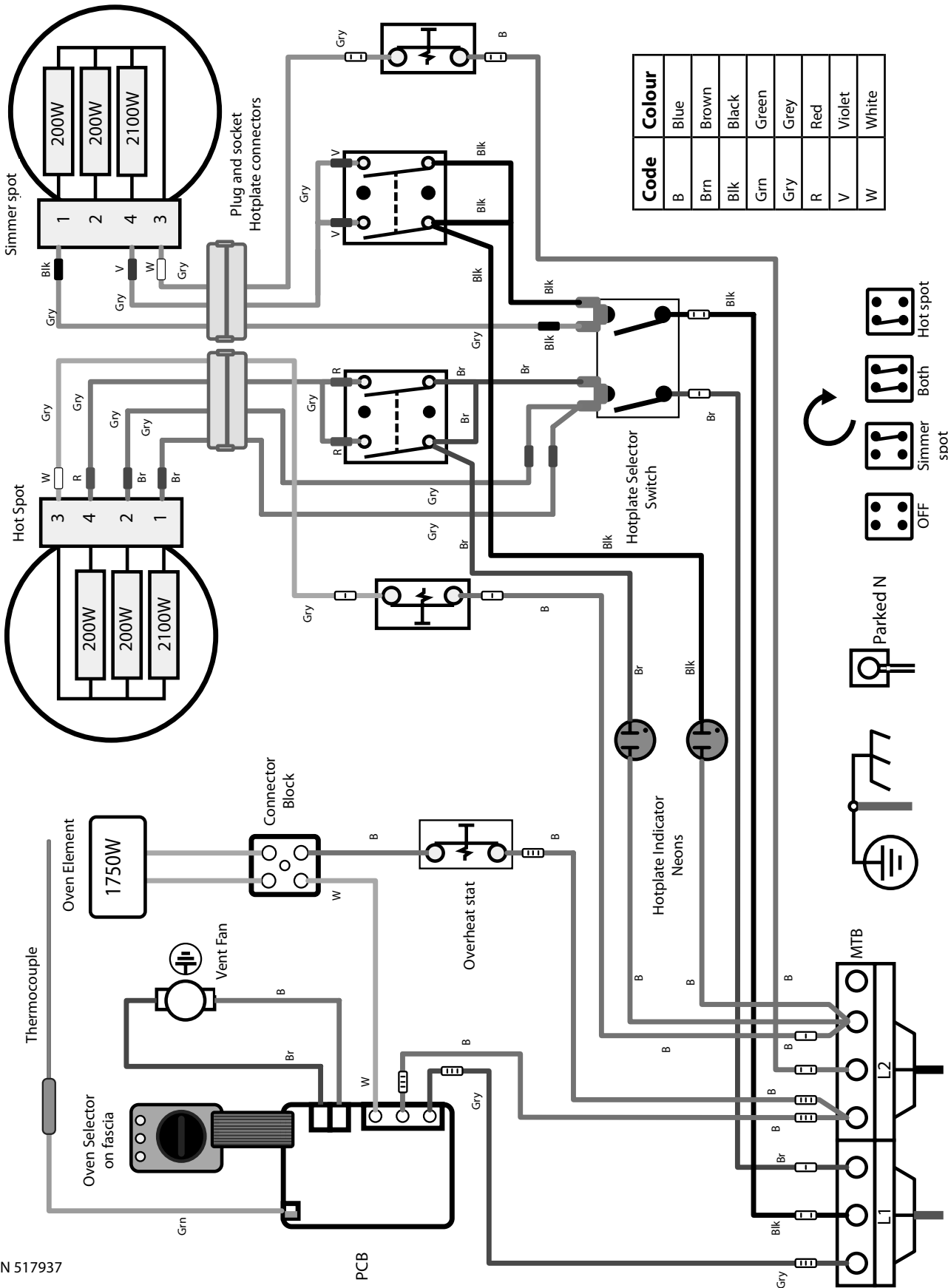

DESN 517937

**For further advice or information contact
your local AGA Specialist**

With Middleby Residential policy of continuous product improvement, the Company reserves the right to change specifications and make modifications to the appliance described and illustrated at any time.



Middleby Residential

4960 Golden Pkwy

BLDG 3

Buford, GA 30518

Business 770.932.7282

Fax 770.932.7292

Toll Free Telephone 800.241.9152