

ALFA



MODERNO 3 PIZZE

Data Sheets - Scheda Tecnica



Weight Peso	97 kg 214 lbs	Materials Materiali	Stainless Steel, iron sheet, Ceramic fiber Acciaio inox, lamiera ferro, Fibroceramica
Cooking floor Piano Cottura	90x50 cm 35 x 20 in	Type of refractory Tipo di refrattario	Alumina silicate HeatKeeper™ Firebrick Tavella HeatKeeper™ silico-alluminoso
Max oven temperature Temperatura massima	500°C 1000°F	Recommended fuel Combustibile consigliato	WOOD - Max 2 in diam. logs. trimmings LEGNA - Ciochi diametro Max 5 cm potature
Heating time Minuti per scaldare	30'	Minimum flue draught Tiraggio minimo	11 Pa
Pizza capacity Numero Pizze	3 Pizza Ø30cm	Flue smokes mass flow Flusso volumetrico fumi	49.6 g/s
Rated charge Carica Nominale	8.3 kg/h 18.3 lbs/h	Average consumption Consumo Medio	2 kg/h 4.4 lbs/h
Smoke temperature Temperatura fumi	395°C 743°F	CO emission at 13% O₂ Emissioni CO al 13% O ₂	0.35% 4444 mg/Nm³



made in Italy

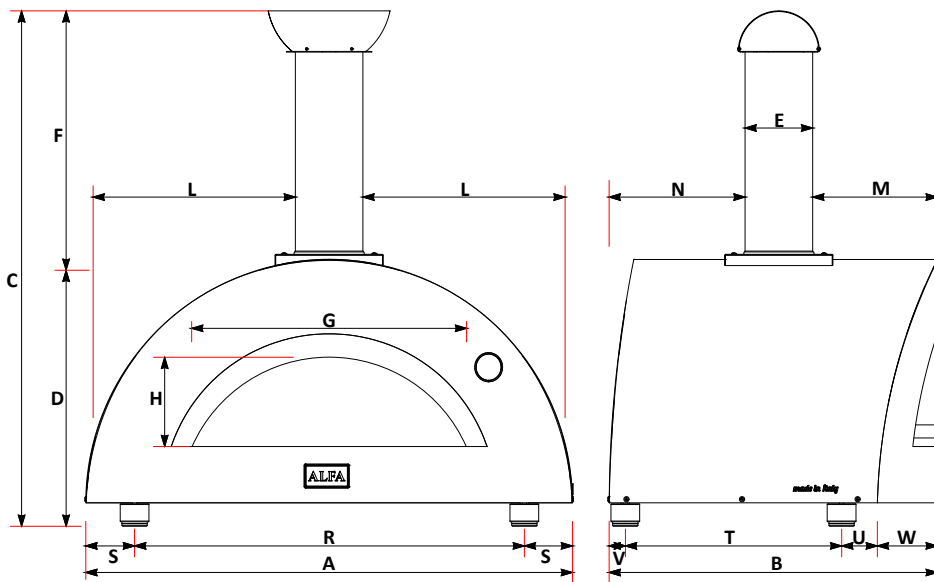

	cm	inch		cm	inch
A	108	42,5	N	30,1	11,9
B	72,8	28,7	O	37,6	14,8
C	114	44,9	P	21,9	8,6
D	60,3	23,7	Q	54	21,3
E	15	5,9	R	86,5	34,1
F	54	21,3	S	10,8	4,3
G	61	24,0	T	48	18,9
H	20	7,9	U	7,95	3,1
L	46,5	18,3	V	3,5	1,4
M	27,7	10,9	W	13,3	5,2

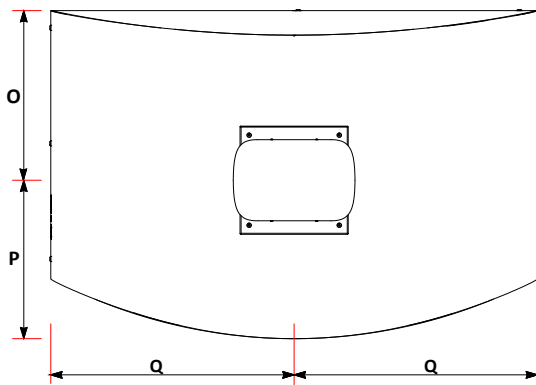

PACKAGING DIMENSIONE IMBALLO				
	Width Larghezza	Depth Profondità	Height Altezza	Weight Peso
cm	114	91	72,5	kg 117
inch	45	35,8	28,5	lbs 258

Description Descrizione	Code Codice
Chimney cap Comignolo	A CMG-1-012
Chimney Canna fumaria	B TI150_480_SAT
Door Sportello	C SPT-1-012
Flange Flangia	D FLG-2-009
External shell Carter esterno	E CRT-1-025
Thermometer Termometro	F YT63-135
Red bricks 30x20 cm Mattoni 30x20 cm	G RRA3020
Feet (n.4) Piedini	H SETPIE-M10X20
Logo Alfa (v1.0)	I D14PLAC-ALFA

