



Install Guide

7 Series Refrigerator Door Skins

VIBDP36, VICDP18, VICDP24

VICDP30, VICDP36

IMPORTANT – Please Read and Follow!

- Before beginning, please read these instructions completely and carefully
- Use caution during assembly to minimize scratches
- Do not remove permanently affixed labels, warnings, or plates from the product. This may void warranty.
- The installer should leave instructions with the customer who should retain for local inspector’s use and future reference.

Model Description:

The table below shows the parts that comes with each of these door panels. Please note that the Bottom Freezer models (VIBDP36RSS, VIBDP36LSS, VIBDP36R**, and VIBDP36L**) have an “R” or “L” in the model number. This denotes the swing direction these panels were designed for. A panel model with an “R” is for a right-hand (right hinge) product, while a panel model with an “L” is for a left-hand (left hinge) product. For all models numbers shown in the table below, “SS” designates a stainless steel version of the door panel, while “**” designates a painted door panel.

Required Tools

- Electric Drill
- T20 Screwdriver (or bit)
- Ratchet and 3/8” socket

Parts Included in each Kit

MODEL	PART	QTY	MODEL	PART	QTY
VICDP18SS	Door Panel, 18”, Stainless Steel	1	VIBDP36RSS	Door Panel, 36”, Right Hand, Stainless Steel	1
	8-18x1/2” Torx 20 Screw	16		Top Drawer Panel, Stainless Steel	1
	084070-000 Install Guide	1		Bottom Drawer panel, Stainless Steel	1
VICDP18**	Door Panel, 18”, Painted	1		8-18 x 1/2" Torx 20 screw	32
	8-18x1/2” Torx 20 Screw	16		084070-000 Install Guide	1
	084070-000 Install Guide	1	VIBDP36LSS	Door Panel, 36”, Left Hand, Stainless Steel	1
VICDP24SS	Door Panel, 24”, Stainless Steel	1		Top Drawer Panel, Stainless Steel	1
	8-18x1/2” Torx 20 Screw	16		Bottom Drawer panel, Stainless Steel	1
	084070-000 Install Guide	1		8-18 x 1/2" Torx 20 screw	32
VICDP24**	Door Panel, 24”, Painted	1		084070-000 Install Guide	1
	8-18x1/2” Torx 20 Screw	16	VIBDP36R**	Door Panel, 36”, Right Hand, Painted	1
	084070-000 Install Guide	1		Top Drawer Panel, Painted	1
VICDP30SS	Door Panel, 30”, Stainless Steel	1		Bottom Drawer panel, Painted	1
	8-18x1/2” Torx 20 Screw	16		8-18 x 1/2" Torx 20 screw	32
	084070-000 Install Guide	1		084070-000 Install Guide	1
VICDP30**	Door Panel, 30”, Painted	1	VIBDP36L	Door Panel, 36”, Left Hand, Painted	1
	8-18x1/2” Torx 20 Screw	16		Top Drawer Panel, Painted	1
	084070-000 Install Guide	1		Bottom Drawer panel, Painted	1
VICDP36SS	Door Panel, 36”, Stainless Steel	1		8-18 x 1/2" Torx 20 screw	32
	8-18x1/2” Torx 20 Screw	16		084070-000 Install Guide	1
	084070-000 Install Guide	1	VICDP36**	Door Panel, 36”, Painted	1
VICDP36**	8-18x1/2” Torx 20 Screw	16		8-18x1/2” Torx 20 Screw	16
	084070-000 Install Guide	1		084070-000 Install Guide	1

Installation

To install:

1. Remove side trim from the foamed door to expose the door skin mounting holes and door skin adjustment cams.
2. Using a T20 bit or screwdriver, partially drive 8-18 screws provided into the hole related to the slotted location on the mounting channels (see images on following pages for reference). Screw should be driven about halfway into the door panel.
 - a. For a column product (All Refrigerator / All Freezer), or for a Bottom Freezer upper panel, use the 2nd hole from the top and the bottom hole (see images on the following pages for reference).
 - b. For a Bottom Freezer drawer panel, use the top hole and the bottom hole.
3. Align the panel with the full product, using the partially inserted screws to latch the panel to the door side channels.
4. Carefully open the door and drive the partially inserted screws the rest of the way, securing the panel to the door side channels.
5. Insert the remaining screws to fully mount the door panel to the main door.
6. Before reapplying the side trim, use the 3/8" socket and ratchet to adjust the door panel using the cams on both sides of the door.
 - a. If the door must be realigned, loosen all screws holding the channels on either side of the door to allow adjustment using a T20 bit or screwdriver. This includes the screws with the cams. **DO NOT REMOVE ANY SCREWS**, there is room for the channels to move with the screws partially installed.
 - b. Using the 3/8" socket and ratchet, slowly adjust the top/bottom cams to align the face of the door panel with the cabinets, and to ensure the panel is level. Be sure to do this on both sides.
 - c. Using the 3/8" socket and ratchet, slowly adjust the middle cams to align the top/bottom of the door vertically. Be sure to do this on both sides.
 - d. Once the door panel(s) is properly aligned, secure all screws using the T20 bit or screwdriver.
7. Snap the side trim back into place by pressing on the outside of the trim with your hands over the area with the white clips. The side trim should be pressed up against the top endcaps.

Installation Bottom Mount Panels

Remove door trim from both side of the door to expose mounting holes for the door skins

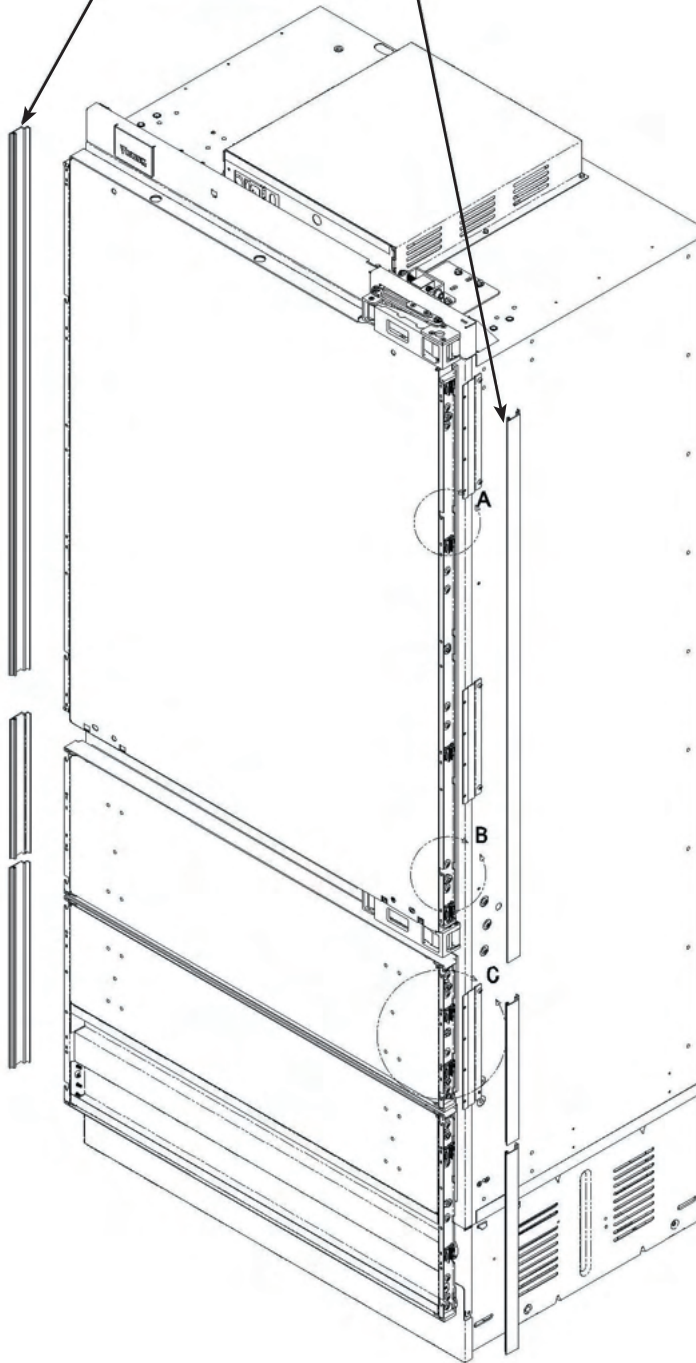

Details A-C show the door skins' mounting holes in the side channels for a bottom mount. The 2nd hole from the top and the bottom hole are to be used for the partially driven screws described in step 2.

Details B and C show some of the CAMs for door skin adjustments (step 6).

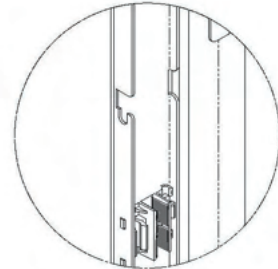

DETAIL A

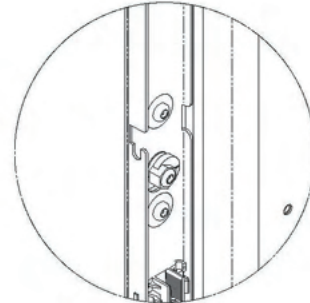

DETAIL B

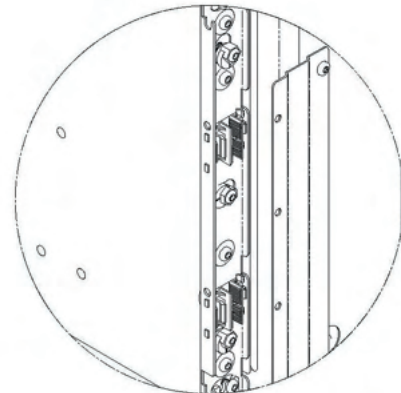

DETAIL C

Installation Bottom Mount Panels

Mounting Hole Locations

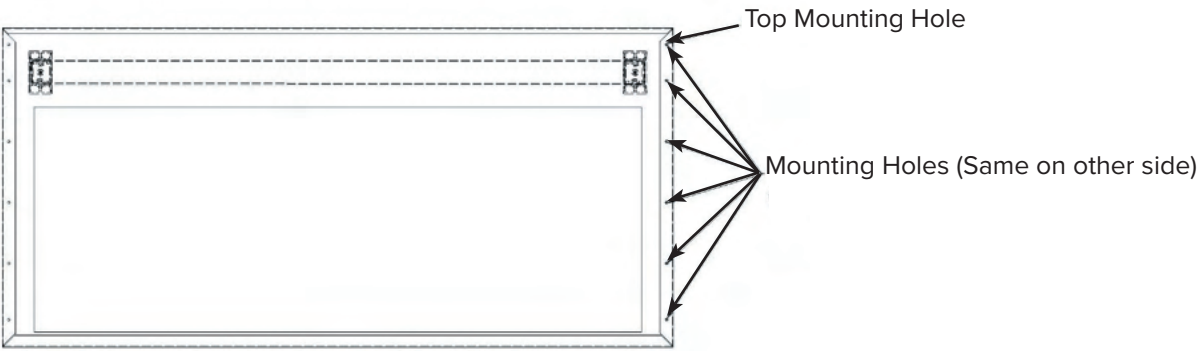
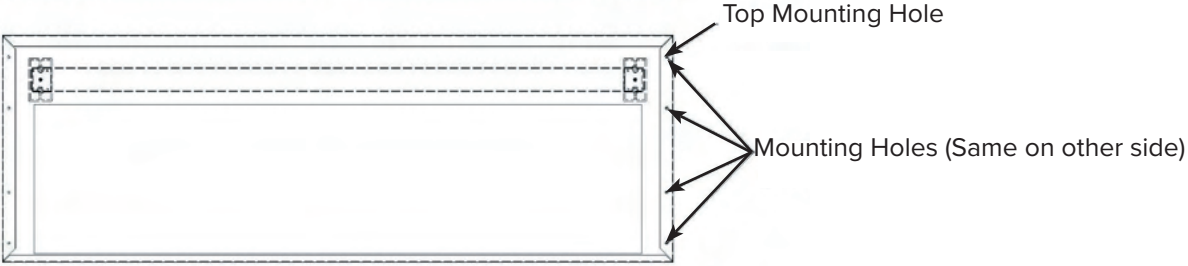
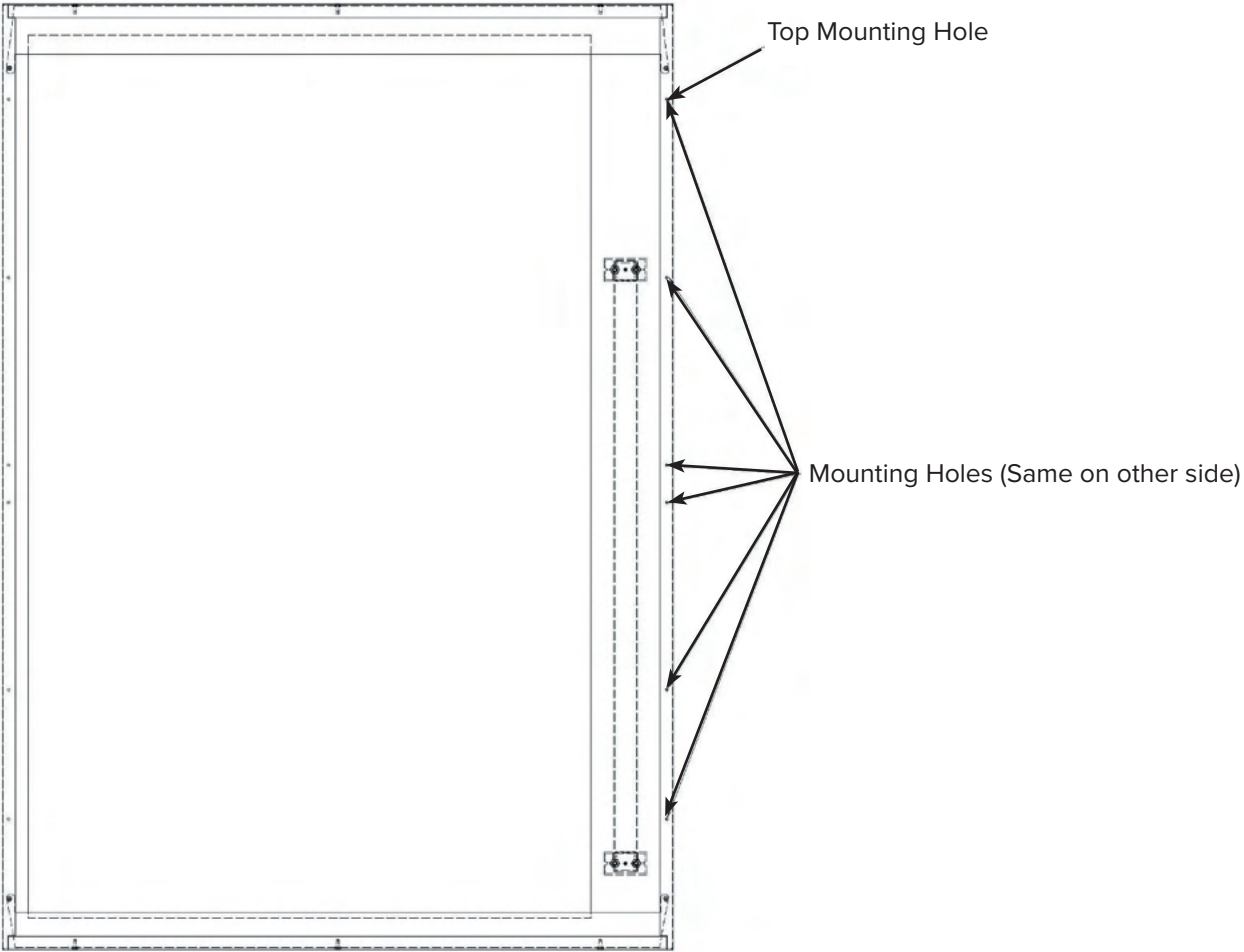

REAR VIEW

Installation Bottom Mount Panels

Determining Correct Mounting Hole Locations
For Bottom Mount models produced BEFORE REV22

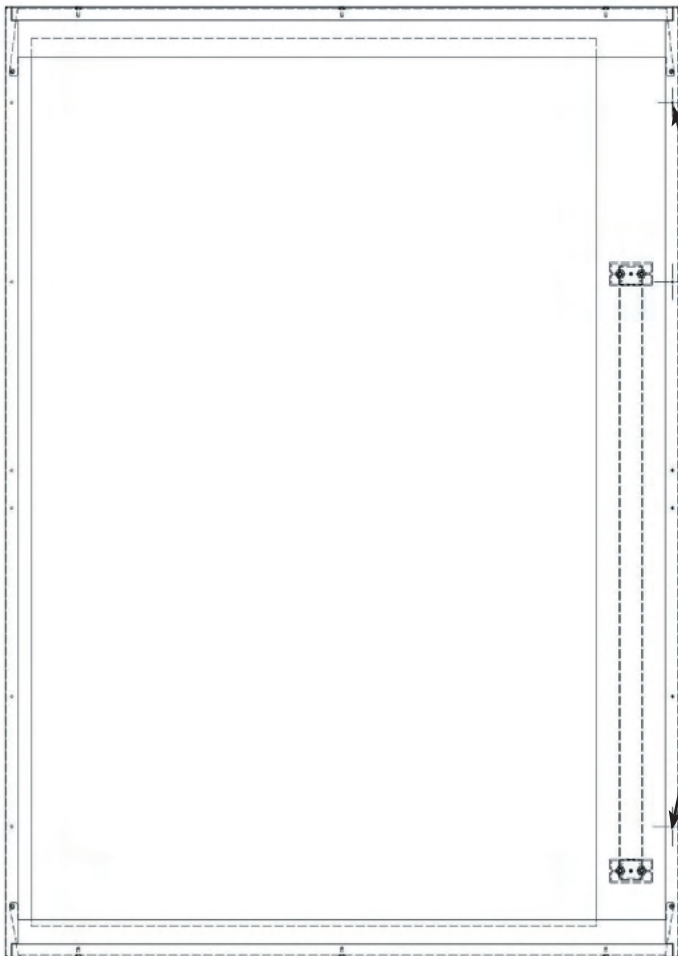

Partially drive screws in these holes on each side for hanging panel prior to fully securing it to the floor

2nd hole from top
Bottom hole

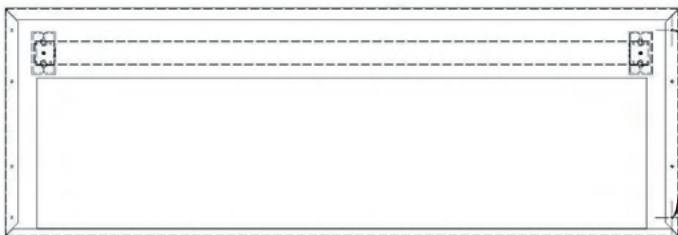

Partially drive screws in these holes on each side for hanging panel prior to fully securing it to the floor

Top hole
Bottom hole

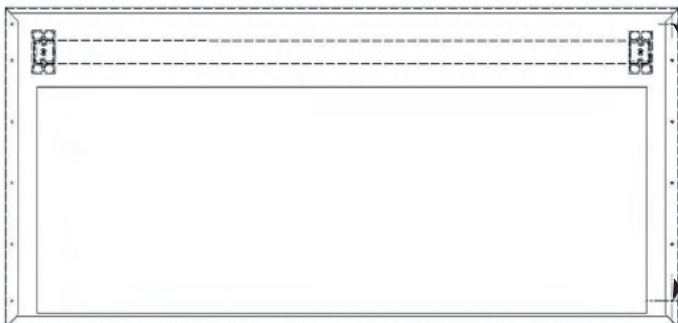

Partially drive screws in these holes on each side for hanging panel prior to fully securing it to the floor

Top hole
Bottom hole

REAR VIEW

Installation Bottom Mount Panels

Determining Correct Mounting Hole Locations
For Bottom Mount models produced REV 22 and AFTER

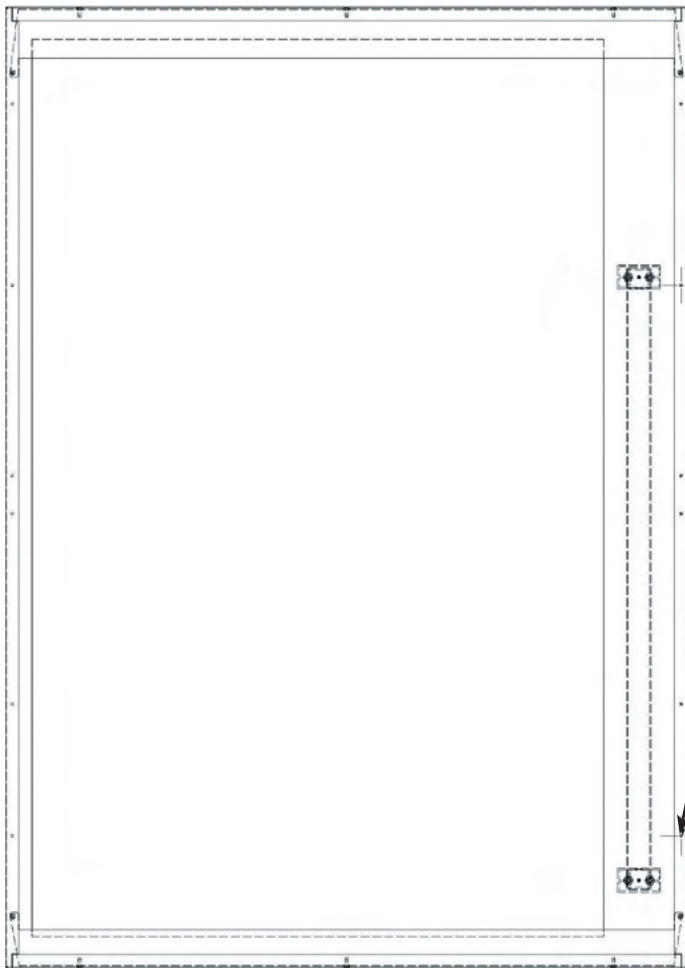

Partially drive screws in these holes on each side for hanging panel prior to fully securing it to the floor

2nd hole from top
Bottom hole

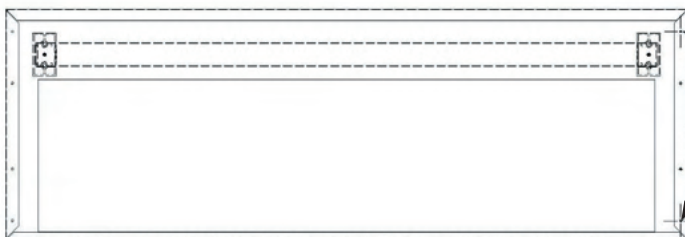

Partially drive screws in these holes on each side for hanging panel prior to fully securing it to the floor

Top hole
Bottom hole

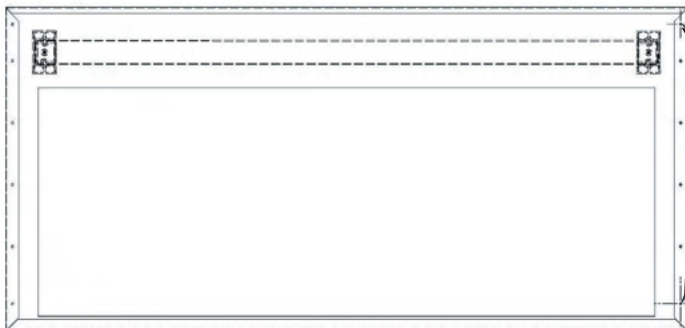

Partially drive screws in these holes on each side for hanging panel prior to fully securing it to the floor

Top hole
Bottom hole

REAR VIEW

Installation Bottom Mount Panels

Details A & B show the screw to latch alignment for the upper door panel.
Detail C shows the screw to latch alignment for the upper drawer. The lower drawer is aligned in the same fashion (step 3)

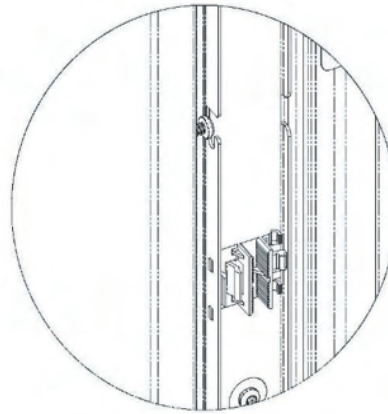
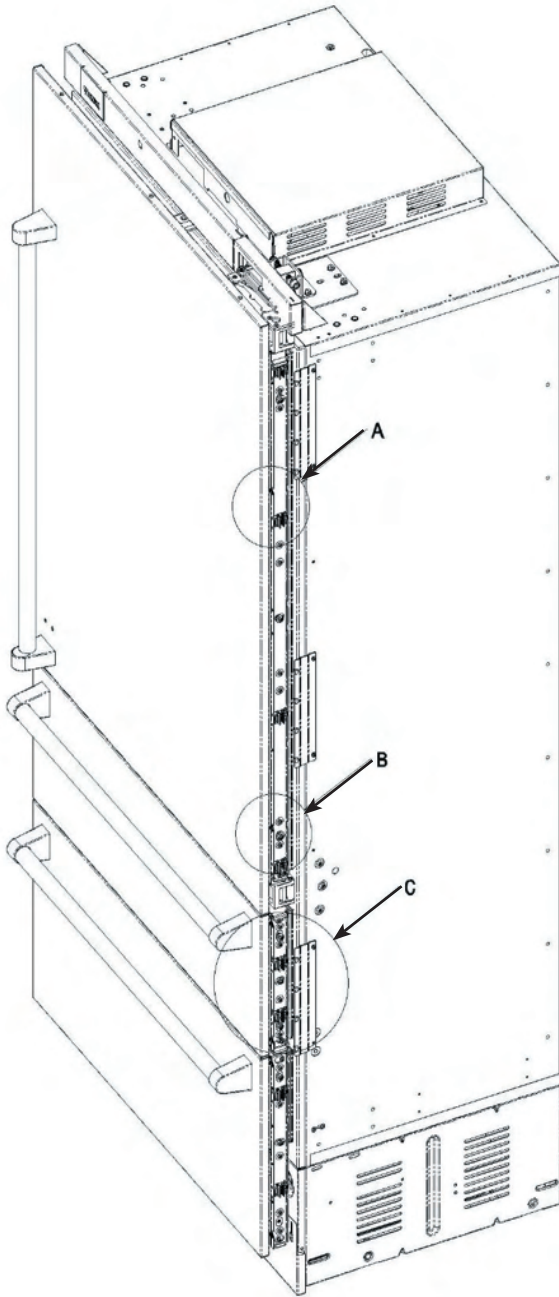

DETAIL A

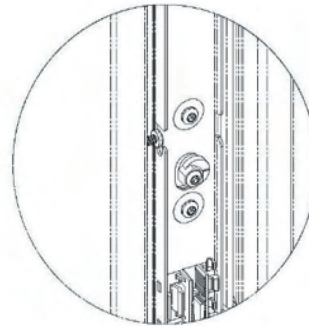

DETAIL B

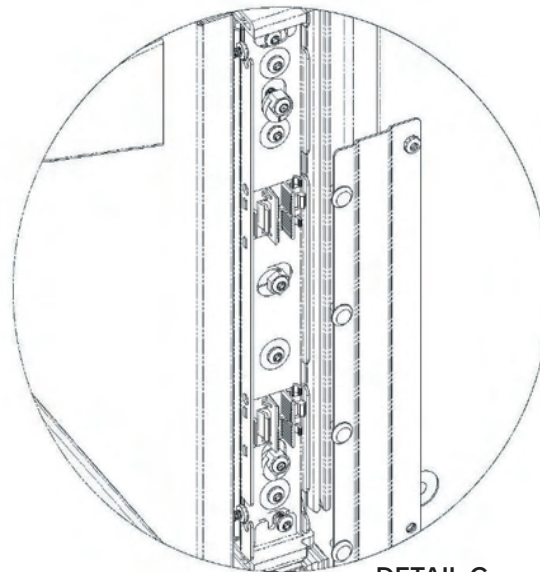

DETAIL C

Installation Column Panels

Remove door trim from both side of the door to expose mounting holes for the door skins

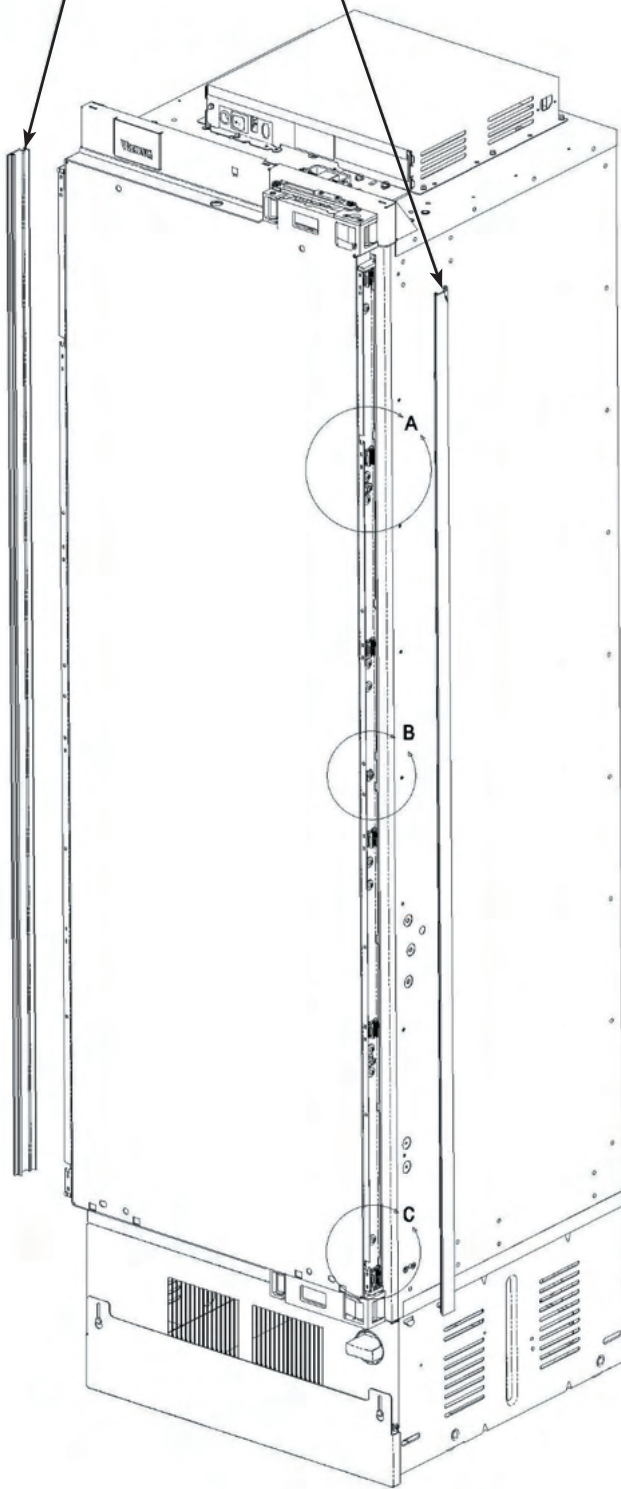

Details A-C show the door skins' mounting holes in the side channels for a column product. The 2nd hole from the top and the bottom hole are to be used for the partially driven screws described in step 2.

Details A & B show the CAM two of three cams for door skin adjustments (step 6).

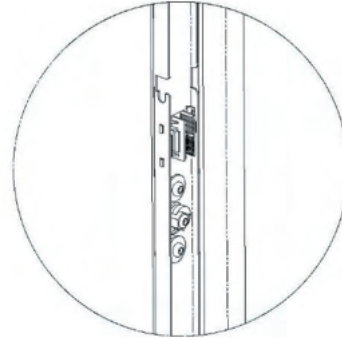

DETAIL A

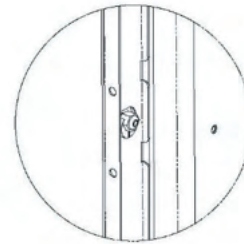

DETAIL B

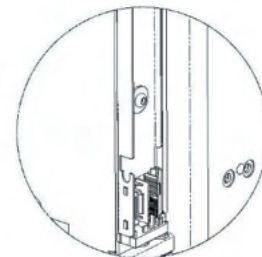

DETAIL C

Installation Column Panels

Mounting Hole Locations

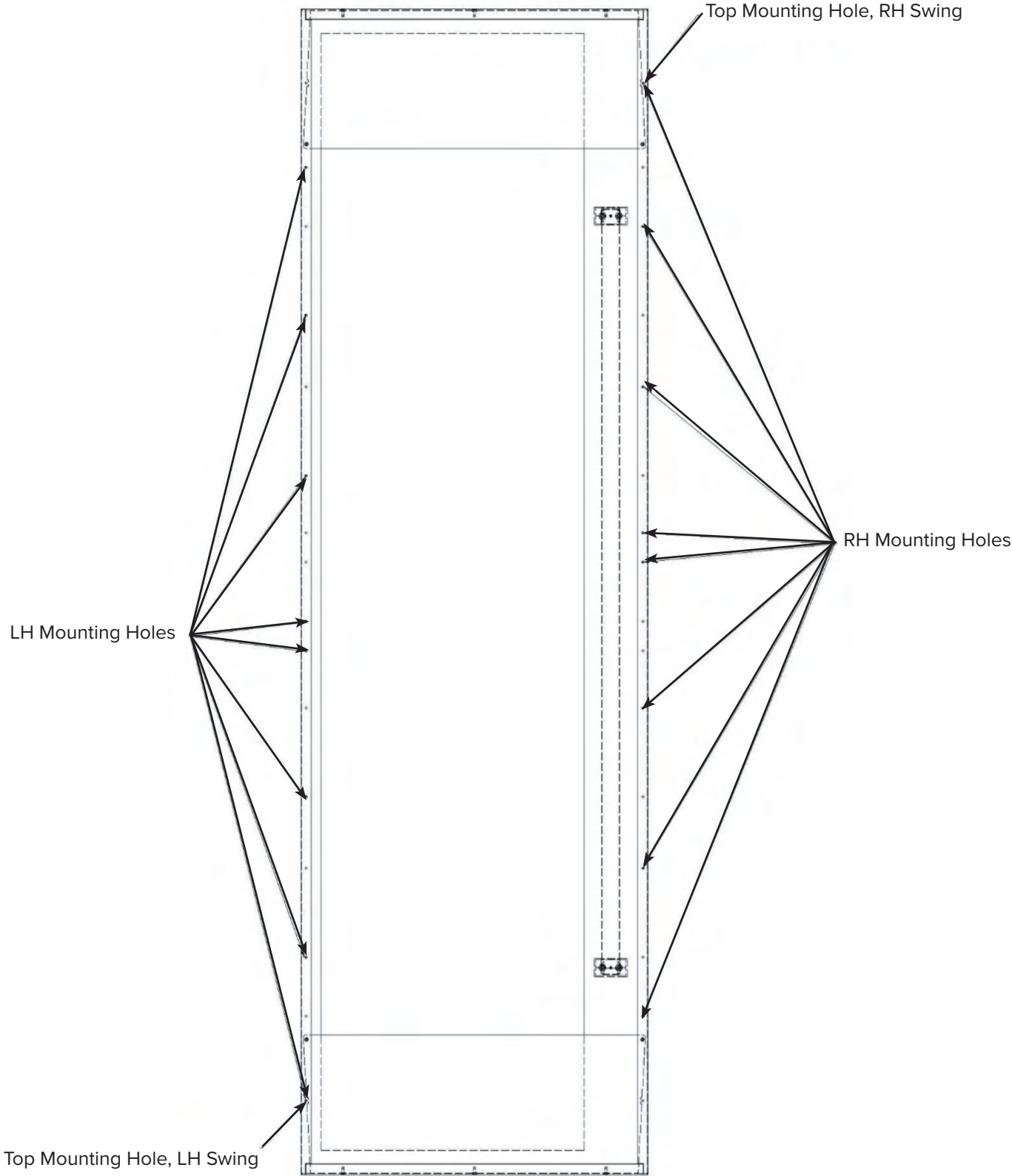

REAR VIEW

Installation Column Panels

Determining Correct Mounting Hole Locations
For Bottom Mount models produced BEFORE REV22

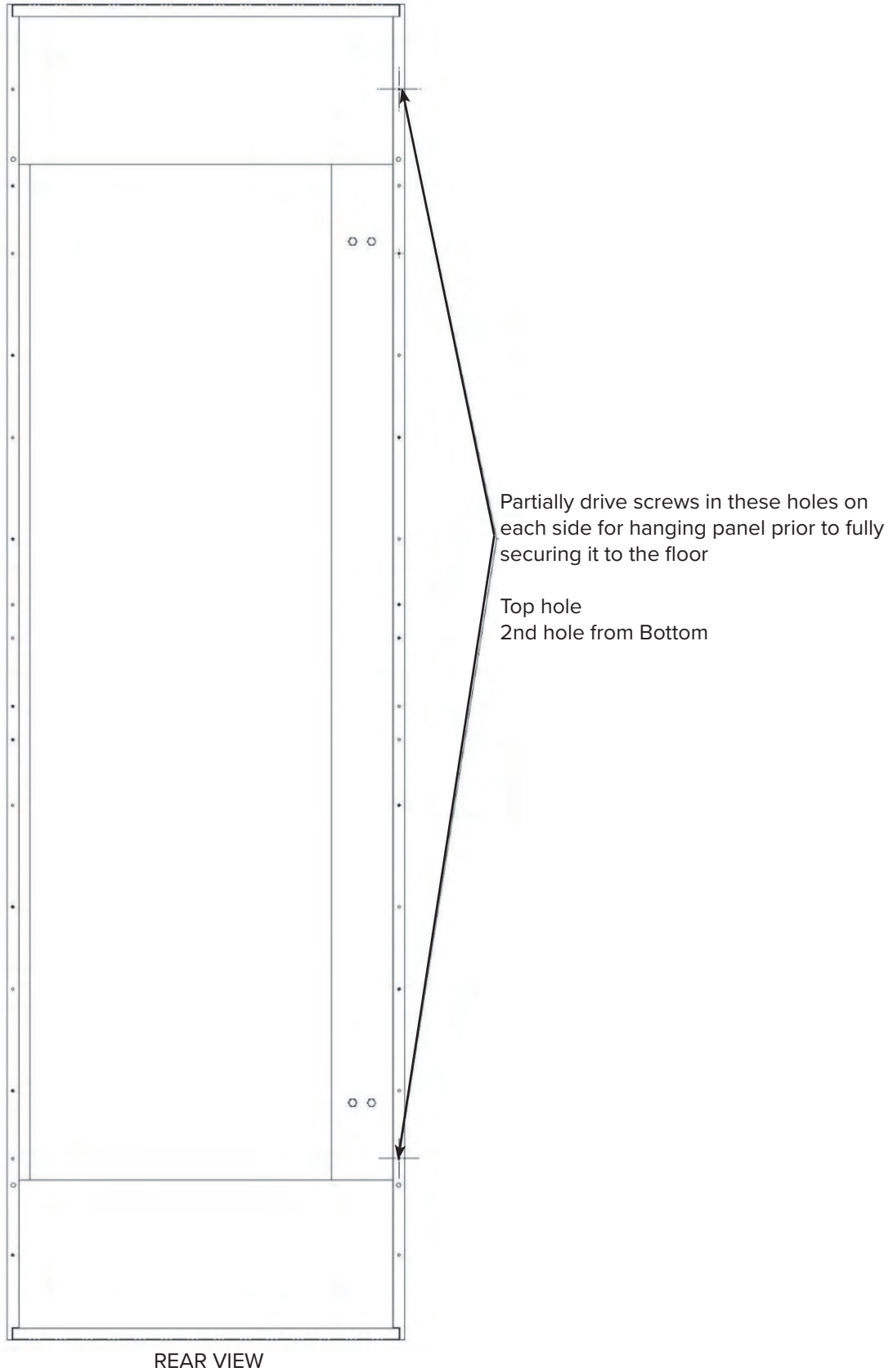

Installation Column Panels

Determining Correct Mounting Hole Locations
For Bottom Mount models produced REV 22 and AFTER

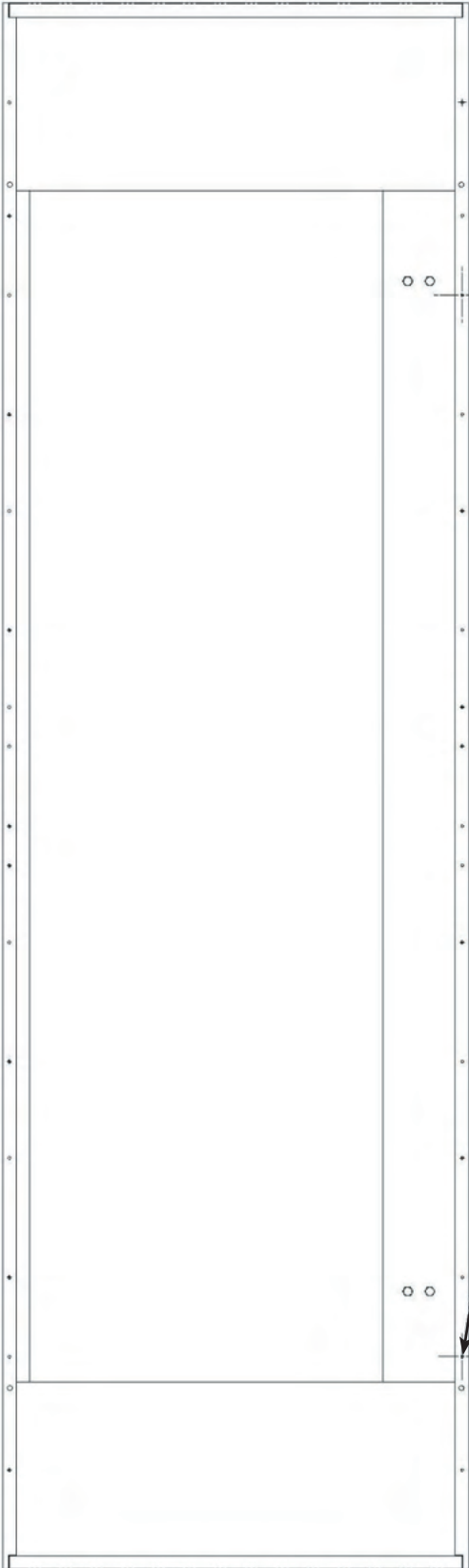

Partially drive screws in these holes on each side for hanging panel prior to fully securing it to the floor

3rd hole from top
2nd hold from bottom

REAR VIEW

Installation Column Panels

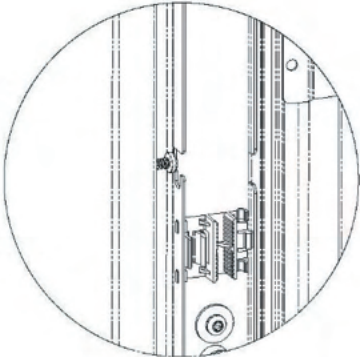
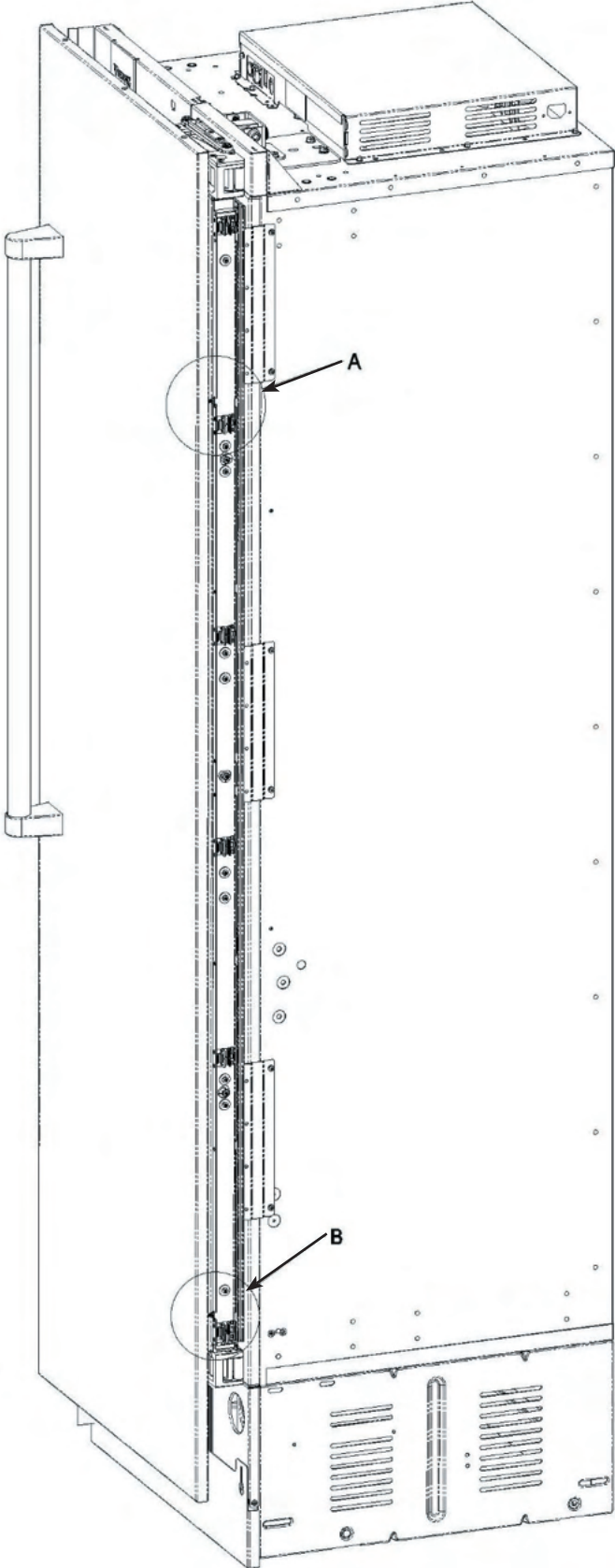

DETAIL A

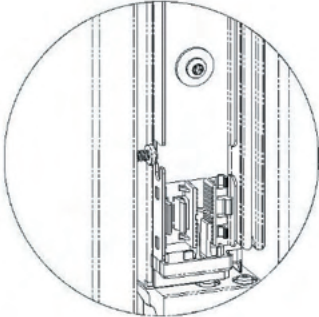

DETAIL B

Viking Range, LLC
111 Front Street
Greenwood, Mississippi 38930 USA
(662) 455-1200

For product information,
call 1-888-(845-4641) or
visit our web site at vikingrange.com.