

Bugaboo Kangaroo sibling seat

Silla para hermanos Bugaboo Kangaroo
Siège secondaire Bugaboo Kangaroo

Parts

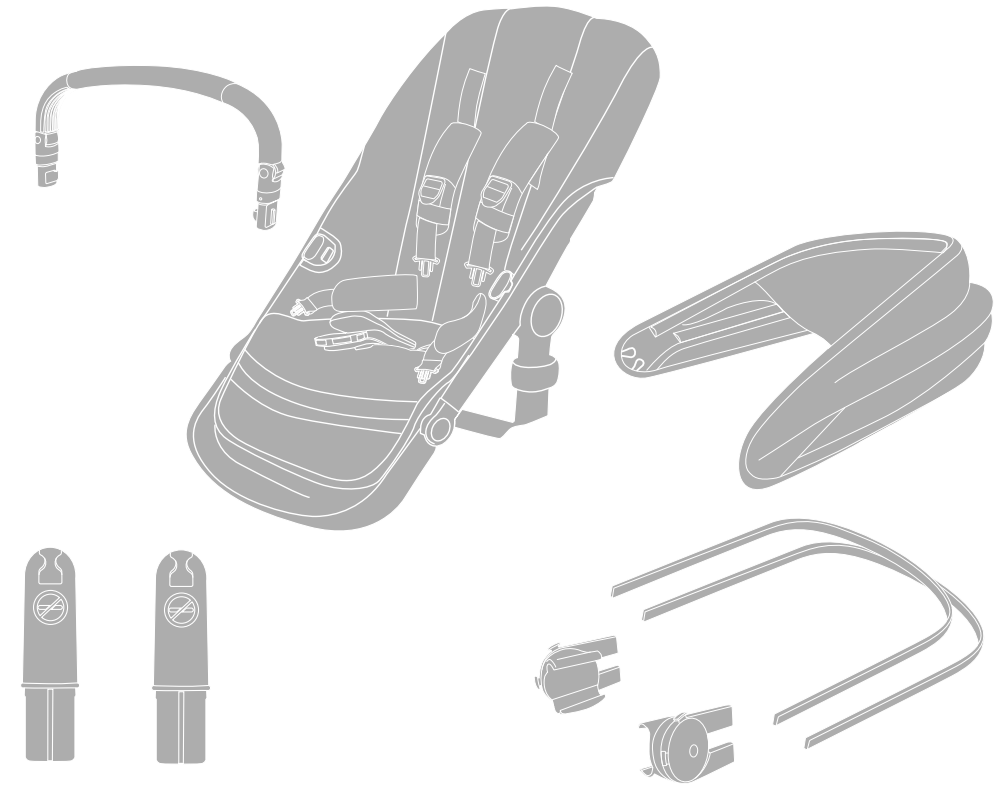

Instructions - visual language



Visual check OK
Comprobación visual correcta
Contrôle visuel OK



Visual check wrong
Comprobación visual incorrecta
Contrôle visuel erreur



Audible click
Clic sonoro
Clic audible



Movement in the indicated direction
Movimiento en la dirección indicada
Mouvement dans le sens indiqué







When you see this symbol in the instructional part of the user guide, please refer to the warnings chapter for ensuring the safe use of the Bugaboo Kangaroo.

Cuando veas este símbolo en las instrucciones de la guía del usuario, consulta el capítulo de advertencias para garantizar un uso seguro del Bugaboo Kangaroo.



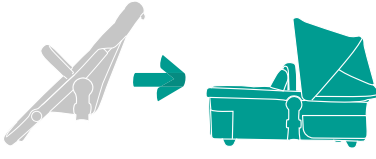
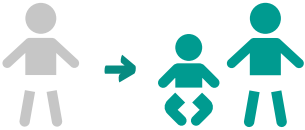



Lorsque vous apercevez ce symbole dans les instructions du mode d'emploi, veuillez vous référer au chapitre sur les avertissements pour garantir une utilisation en toute sécurité de la Bugaboo Kangaroo.

Warnings	 EN	4
	 ES	6
	 FR	8

Set-up		10
		11
		13
		14
		20
		21

	26
---	----

Configurations	31
----------------	----

Features		32
		33
		34
		35
		36
		37

WARNINGS and useful safety information

IMPORTANT READ CAREFULLY AND KEEP FOR FUTURE REFERENCE. YOUR CHILD'S SAFETY MAY BE AFFECTED IF YOU DON'T FOLLOW THEM.

1. A child's safety is your responsibility.
2. **NEVER** leave the child(ren) unattended.
3. To use the stroller with two children, adapt the chassis to double mode by reversing and securing the central seat lugs until the correct configuration (1 child or 2 children) is shown as green.
4. Before use ensure that the central seat lugs are securely attached to the chassis.
5. Ensure the sibling lower adapters are secured on the chassis before attaching bassinet or sibling seat.
6. Ensure the sibling seat or bassinet or car seat is secured on the sibling lower adapters before use.
7. Only use the recommended configurations specified in this user guide
8. This seat is suitable up to a weight of 40 lbs / 18 kg. Excessive weight may cause a hazardous unstable condition to exist.
9. Always apply the brake when loading or unloading your child in the sibling seat.
10. When using the stroller in double mode:
 - First secure both seat/bassinet units on the chassis before a child is placed in either upper or lower position;
 - Place the second child into the sibling seat after the first child is placed and secured in the main seat;
 - Ensure the child in the upper position is removed from the stroller before removing the sibling seat or bassinet from the lower position, to avoid risk of tipping over.
 - When car seat is in upper position and other child sits in lower position, do not lower the car seat carry handle to the horizontal position to prevent it from interfering or accidentally falling on child's head.
11. Avoid serious injury from falling or sliding out. Always use the complete five-point harness.
12. Always monitor the child sitting in the lower position.
13. Always adjust the chassis to single mode and use upper position when carrying one child only.
14. Do not allow the child to stand on the footrest, risk of tipping over.
15. Children can reach out to the goods placed in the under seat basket, remove the goods if necessary.
16. Only remove central axis for changing from single to double mode and vice versa, always keep it at the chassis during use.
17. The sibling seat can only be used on chassis, not as a stand alone seat unit.
18. Please ensure that a different care taker is instructed on how to use the product in the correct way.

Questions and feedback

You can contact our Customer Support Team using our online contact form (www.Bugaboo.com/support).

The information contained herein is subject to change without notice. Bugaboo International BV shall not be liable for technical errors or omissions contained herein. The purchased product may differ from the product as described in this user guide. Our most recent user guides can be requested at our service departments or at www.bugaboo.com.
© 2023 Bugaboo International BV. BUGABOO CAMELEON, BUGABOO BEE, BUGABOO DONKEY, BUGABOO FOX, BUGABOO TURTLE, BUGABOO LYNX, BUGABOO STARDUST, BUGABOO OWL, BUGABOO BUTTERFLY, BUGABOO GIRAFFE, BUGABOO DRAGONFLY, BUGABOO KANGAROO and the Bugaboo logos are registered trademarks. The Bugaboo strollers are patented and design protected.

ADVERTENCIAS y información de seguridad

IMPORTANTE – LEER LAS INSTRUCCIONES CUIDADOSAMENTE ANTES DEL USO Y MANTENERLAS PARA FUTURAS CONSULTAS.

1. La seguridad de un niño es su responsabilidad.
2. NO dejes nunca al niño desatendido.
3. Para usar el carrito con dos niños, adapta el chasis al modo doble invirtiendo y asegurando los soportes de silla hasta que la configuración correcta (1 niño o 2 niños) se muestre en color verde.
4. Antes de usar, asegúrate de que los soportes de silla estén acopladas correctamente al chasis.
5. Asegúrate de que los adaptadores inferiores para hermanos estén asegurados en el chasis antes de colocar el capazo o la silla para hermanos.
6. Asegúrate de que la silla para hermanos, o capazo o silla de coche esté asegurada en los adaptadores inferiores para hermanos antes de su uso.
7. Utiliza únicamente las configuraciones recomendadas que se especifican en esta guía del usuario
8. Esta silla es adecuada para llevar un peso de hasta 40 lbs / 18kg. El peso excesivo puede provocar una inestabilidad peligrosa.
9. Utiliza siempre el freno al sacar y colocar a tu niño de la silla para hermanos.
10. Cuando uses el carrito en modo doble:
 - Primero asegura las unidades de silla/capazo en el chasis antes de colocar al niño en la posición superior o inferior;
 - Coloca el segundo hijo en la silla para hermanos después de colocar y asegurar el primer hijo en la silla principal;
 - Asegúrate de sacar al niño de la posición superior del carrito antes de retirar la silla para hermanos o el capazo de la posición inferior, para evitar el riesgo de vuelco.
 - Cuando la silla de coche esté en la posición superior y otro niño esté sentado en la posición inferior, no bajes el asa de transporte de la silla de coche a la posición horizontal para evitar que interfiera o caiga accidentalmente sobre la cabeza del niño.
11. Evita lesiones graves por caídas o deslizamientos. Utiliza siempre el arnés de cinco puntos completo.

12. Controla siempre al niño cuando esté sentado en la posición inferior.
13. Ajusta siempre el chasis al modo individual y utiliza la posición superior cuando lleves a un solo niño.
14. No permitas que el niño se suba sobre el reposapiés, existe riesgo de que se vuelque.
15. Los niños pueden llegar a alcanzar los objetos colocados en la cestilla de compras, si es necesario retíralos.
16. Extrae únicamente el eje central para cambiar del modo individual al doble y, viceversa. Mantenlo siempre en el chasis durante su uso.
17. Esta modalidad de uso no es aplicable a la silla para hermanos Bugaboo Kangaroo.
18. Por favor, asegúrate que cualquier otra persona que use el producto reciba instrucciones sobre cómo utilizarlo de forma correcta.

Preguntas y comentarios

Puedes contactar con nuestro equipo de Atención al Cliente utilizando nuestro formulario de contacto online (www.bugaboo.com/support).

La información de estas instrucciones puede modificarse sin previo aviso. Bugaboo International BV no se hace responsable de los errores técnicos u omisiones que contengan. El producto adquirido puede diferir del descrito en esta guía del usuario. Puedes solicitar la guía del usuario más reciente a nuestros departamentos de atención al cliente o en www.bugaboo.com.
© 2023 Bugaboo International BV. BUGABOO CAMELEON, BUGABOO BEE, BUGABOO DONKEY, BUGABOO FOX, BUGABOO TURTLE, BUGABOO LYNX, BUGABOO STARDUST, BUGABOO OWL, BUGABOO BUTTERFLY, BUGABOO GIRAFFE, BUGABOO DRAGONFLY, BUGABOO KANGAROO y los logotipos Bugaboo son marcas comerciales registradas. Los cochecitos de Bugaboo® están patentados y su diseño o está protegido.

AVERTISSEMENTS et autres informations d'utilisation

IMPORTANT – LEER LAS INSTRUCCIONES CUIDADOSAMENTE ANTES DEL USO Y MANTENERLAS PARA FUTURAS CONSULTAS.

1. La sécurité d'un enfant est votre responsabilité.
2. NE jamais laisser un enfant sans surveillance.
3. Si vous souhaitez utiliser la poussette avec deux enfants, adaptez le châssis au mode duo en inversant et en fixant les ergots du siège central jusqu'à ce que la configuration correcte (1 enfant ou 2 enfants) s'affiche en vert.
4. Avant utilisation, assurez-vous que les ergots du siège central sont bien fixés au châssis.
5. Assurez-vous que les adaptateurs de la partie inférieure de la nacelle sont fixés sur le châssis avant de fixer la nacelle ou le siège de la nacelle.
6. Assurez-vous que le siège secondaire, la nacelle ou le siège auto est fixé sur les adaptateurs de partie secondaire du bas avant de l'utiliser.
7. Veuillez utiliser uniquement les configurations recommandées dans la présente notice.
8. Ce siège peut supporter un poids allant jusqu'à 40 lbs / 18 kg. Un excès de poids peut entraîner une instabilité dangereuse.
9. Serrez toujours le frein lorsque vous mettez votre enfant dans le siège de la fratrie ou lorsque vous le retirez de celui-ci.
10. Lorsque la poussette est utilisée en mode duo :
 - Fixez d'abord les deux unités siège/nacelle sur le châssis avant de placer votre enfant en position haute ou basse ;
 - Placez le deuxième enfant dans le siège secondaire une fois que le premier enfant est placé et attaché dans le siège principal ;
 - Assurez-vous que l'enfant en position haute est sorti de la poussette avant de retirer le siège secondaire ou la nacelle en position basse, pour éviter tout risque de basculement.
 - Lorsque le siège auto est en position haute et que l'autre enfant est installé en position basse, n'abaissez pas la poignée de transport du siège auto jusqu'à la position horizontale pour éviter qu'elle n'interfère ou ne tombe accidentellement sur la tête de l'enfant.
11. Évitez les blessures graves dues à une chute ou à un glissement.

- Veillez à toujours utiliser le harnais complet à cinq points d'ancrage.
12. Contrôlez toujours l'enfant assis en position basse.
 13. Veillez à toujours régler le châssis en mode simple et à utiliser la position haute lorsque vous ne transportez qu'un seul enfant.
 14. Ne laissez pas l'enfant se tenir sur le repose-pieds, au risque de le voir basculer.
 15. Les enfants peuvent atteindre les objets placés dans le panier sous le siège, retirez-les si nécessaire.
 16. Ne retirez l'axe central que pour passer du mode simple au mode duo et vice versa, conservez-le toujours sur le châssis pendant l'utilisation.
 17. Ce mode d'utilisation n'est pas applicable au siège secondaire Bugaboo Kangaroo.
 18. Veillez à ce qu'une autre personne soit informée de la manière dont le produit doit être utilisé.

Questions et commentaires

Vous pouvez contacter notre Service clientèle en utilisant notre formulaire de contact en ligne (www.bugaboo.com/support).

Les informations contenues dans la présente sont sujettes à modification sans préavis. La société Bugaboo International BV ne peut être tenue responsable des erreurs techniques ou omissions contenues dans ce document. Il se peut que le produit acheté diffère de la description donnée dans ce guide utilisateur. Vous pouvez demander nos derniers guides utilisateur auprès de notre service clientèle ou sur le site www.bugaboo.com.

© 2023 Bugaboo International BV. BUGABOO CAMELEON, BUGABOO BEE, BUGABOO DONKEY, BUGABOO FOX, BUGABOO TURTLE, BUGABOO LYNX, BUGABOO STARDUST, BUGABOO OWL, BUGABOO BUTTERFLY, BUGABOO GIRAFFE, BUGABOO DRAGONFLY, BUGABOO KNAGAROO et les logos Bugaboo sont des marques déposées. Les poussettes Bugaboo® sont brevetées et protégées.

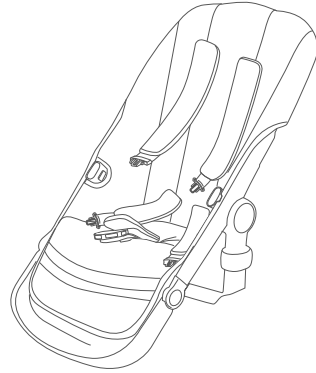
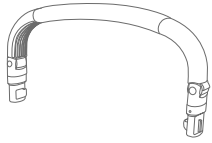

1

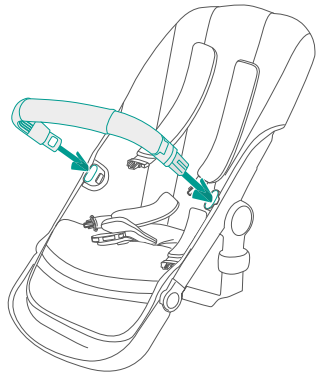

2

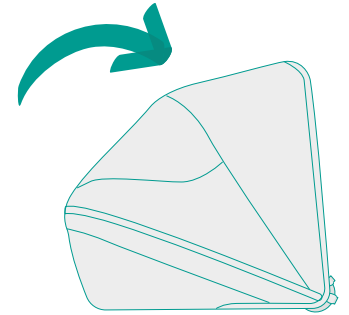
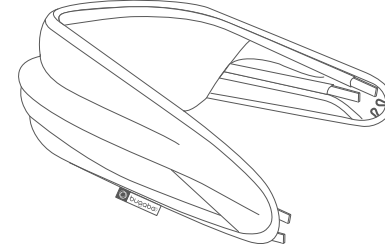
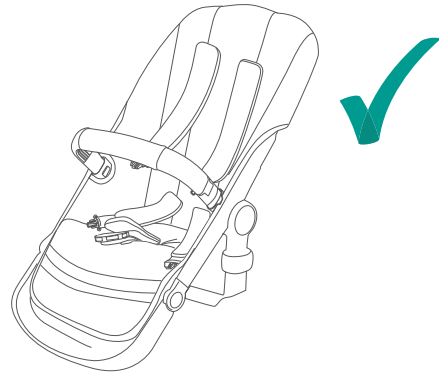

1

2

3

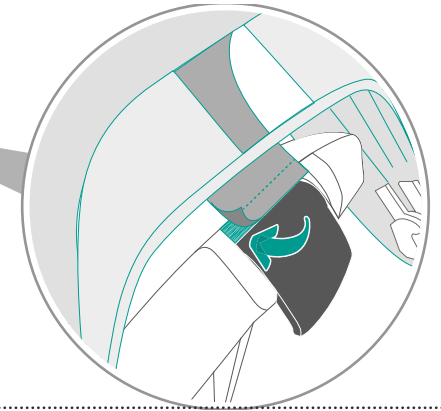
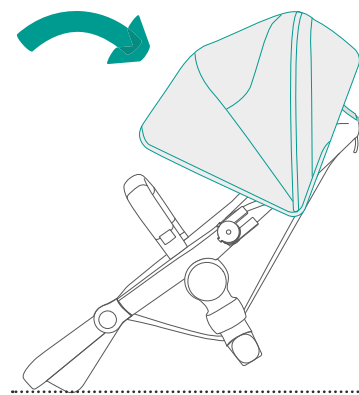

4

5

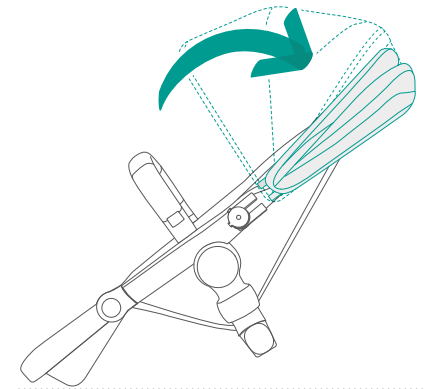
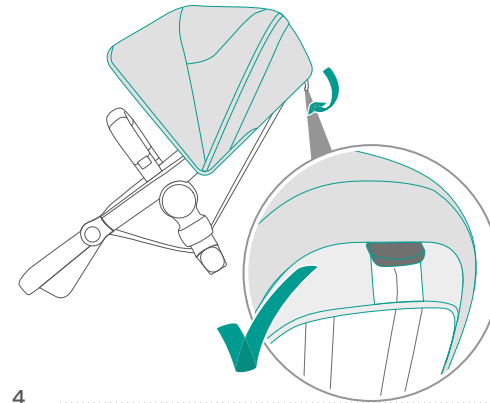

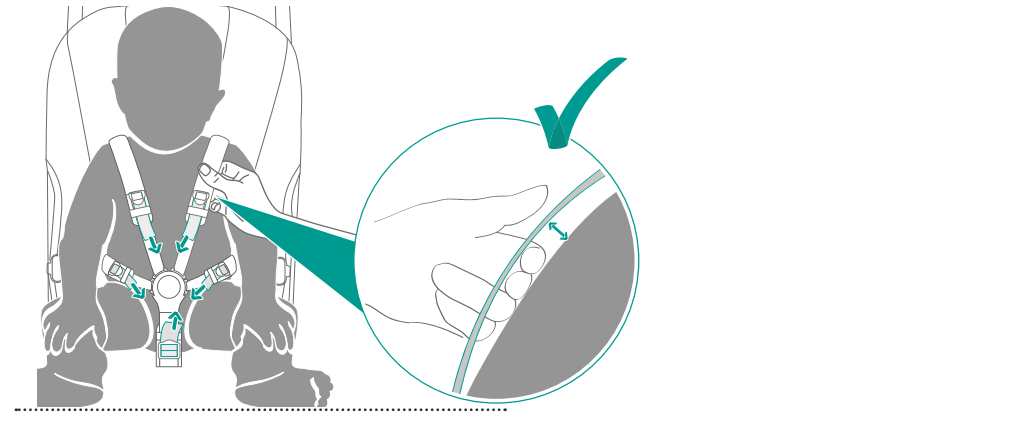
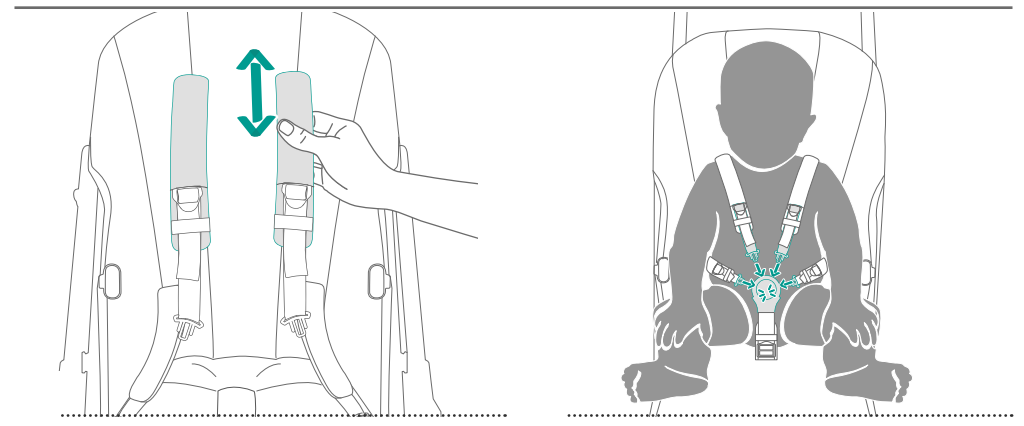
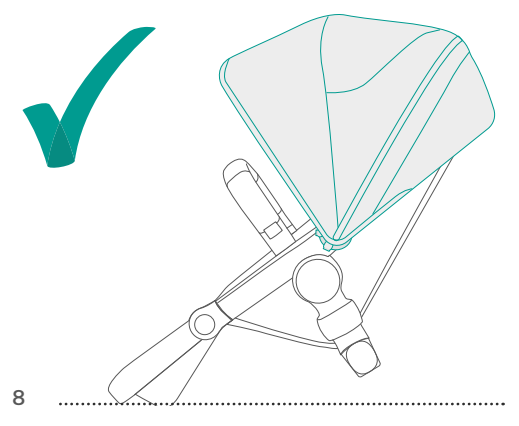
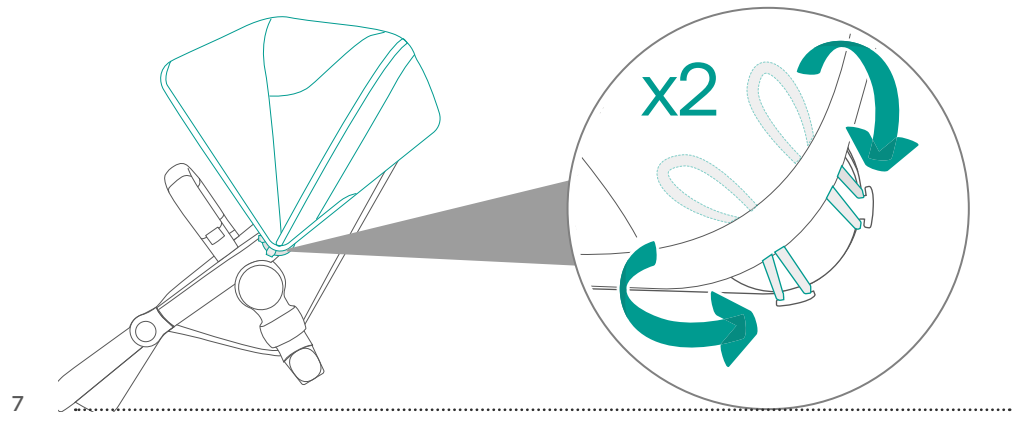
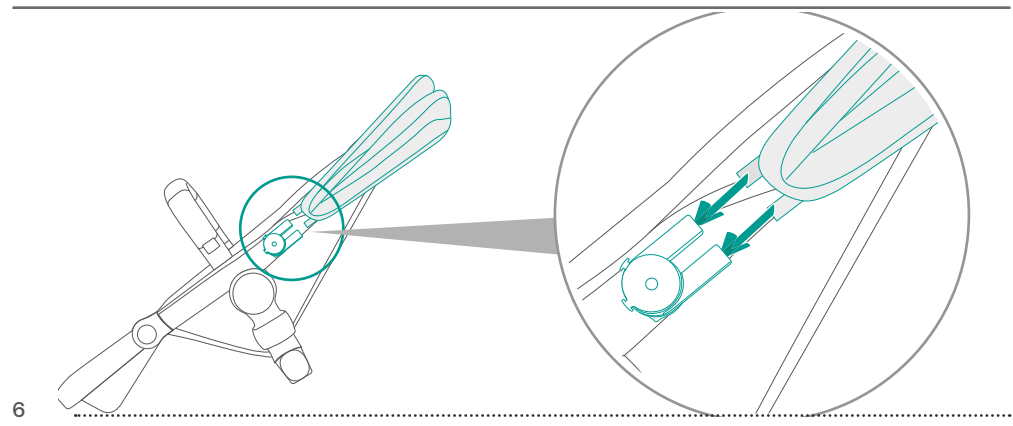

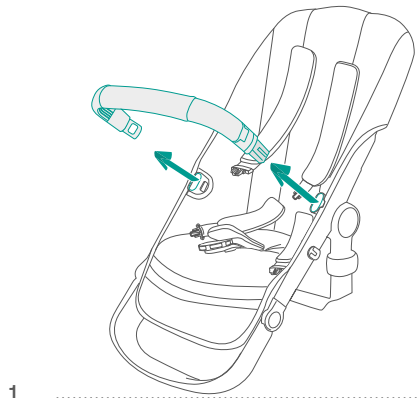
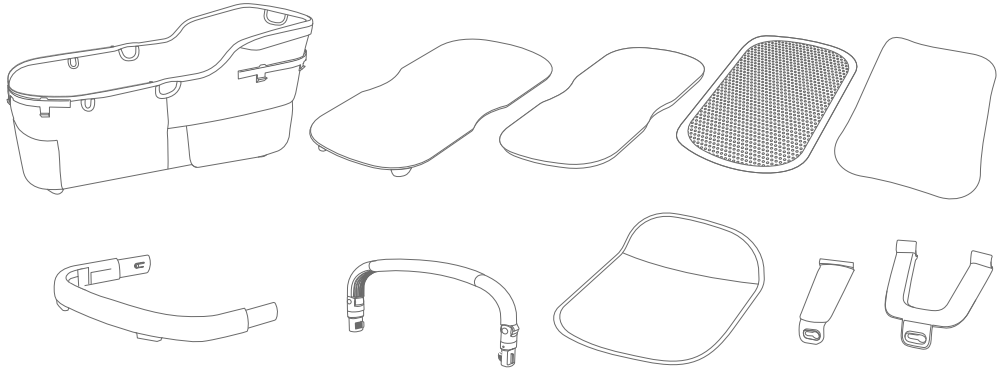
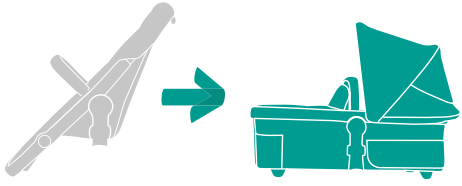

1

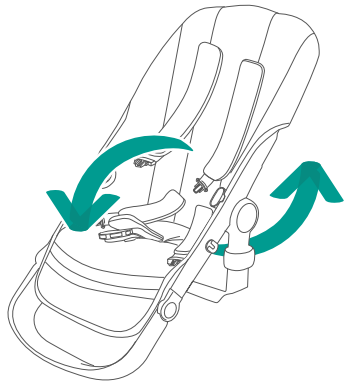

2

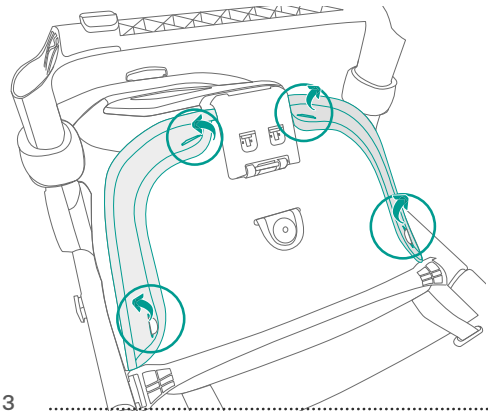

3

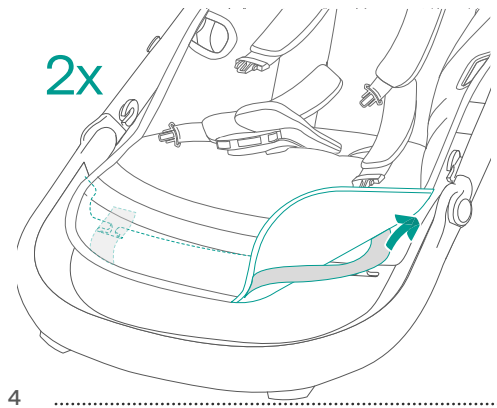

4

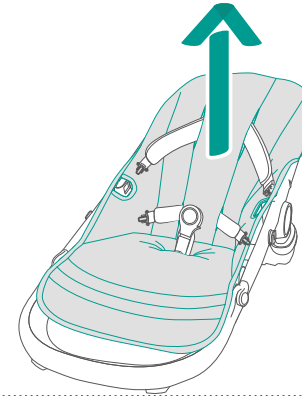

5

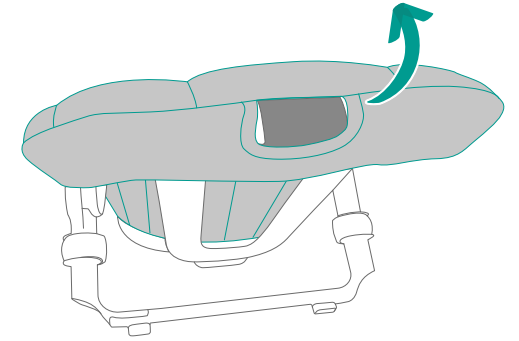

6

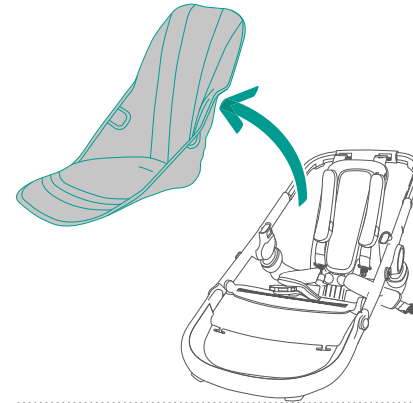

7

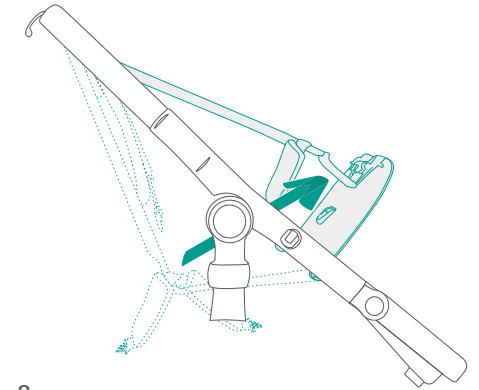

8

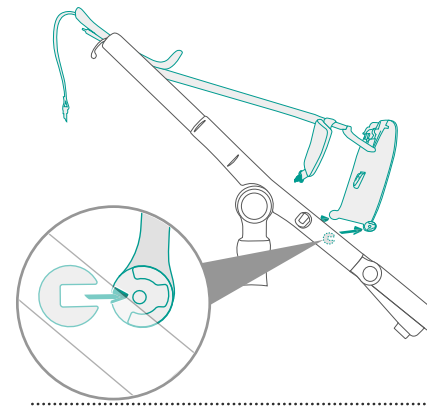

9

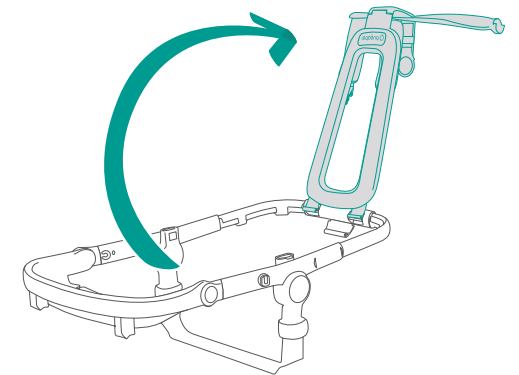

10

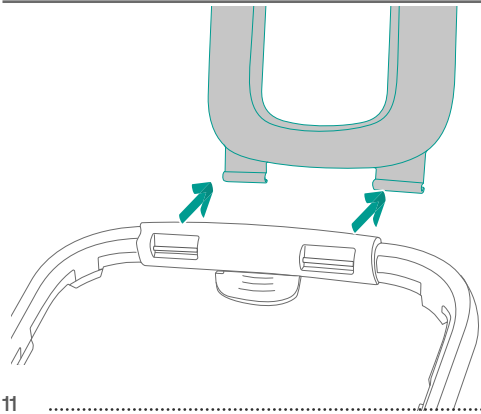

11

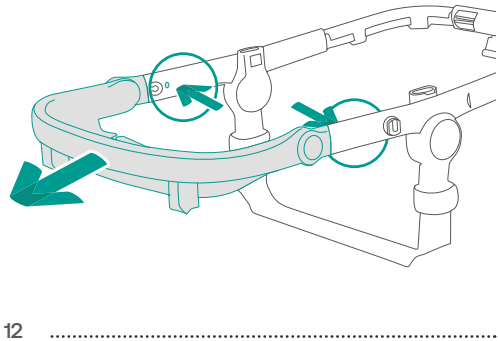

12

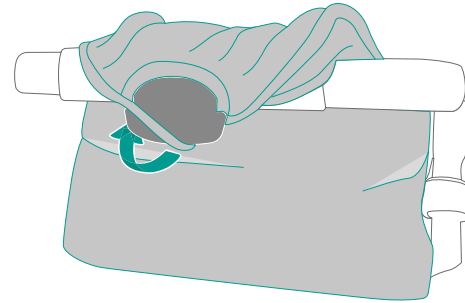

17

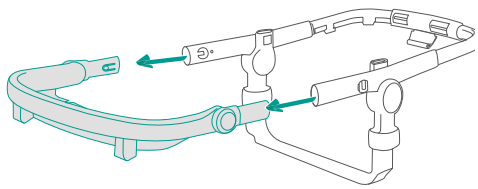

13

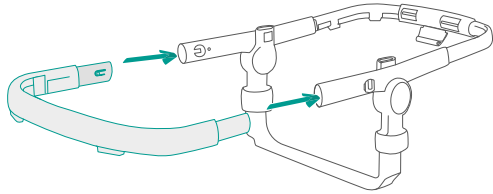

14

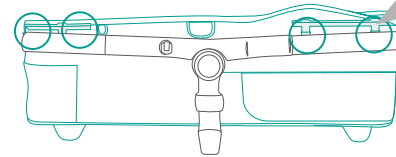

18

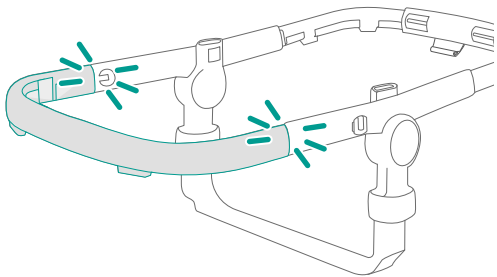

15

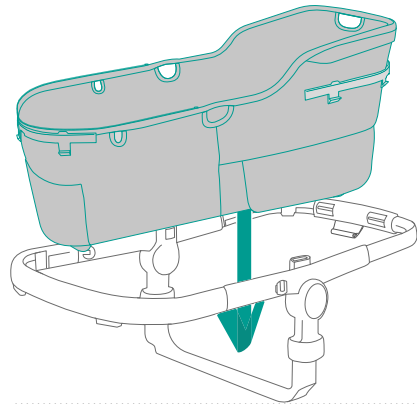

16

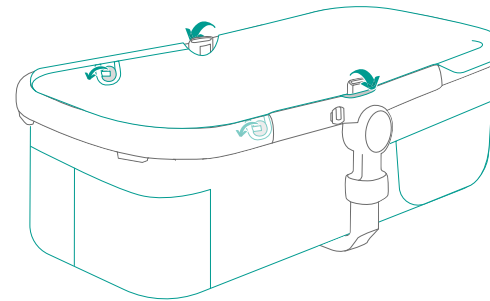

19

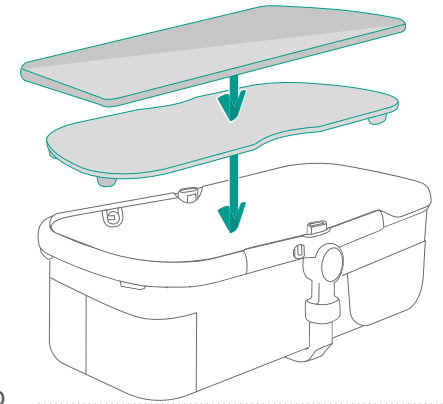

20

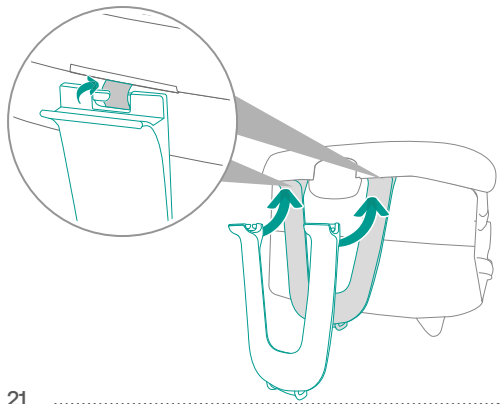

21

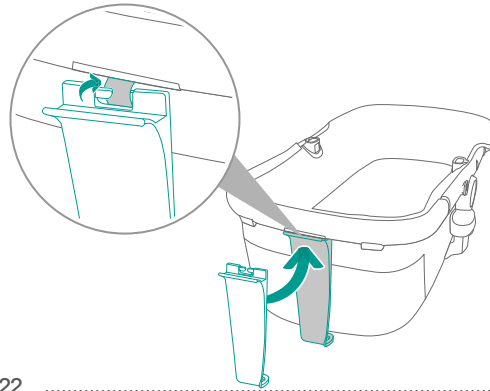

22

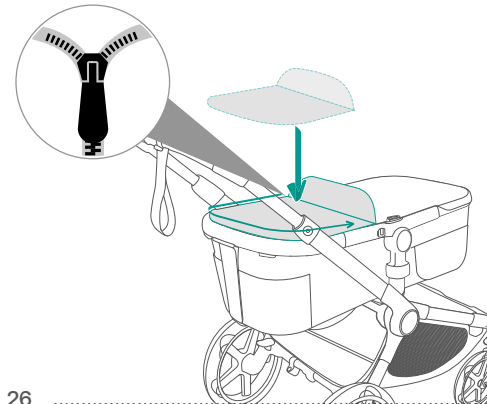

26

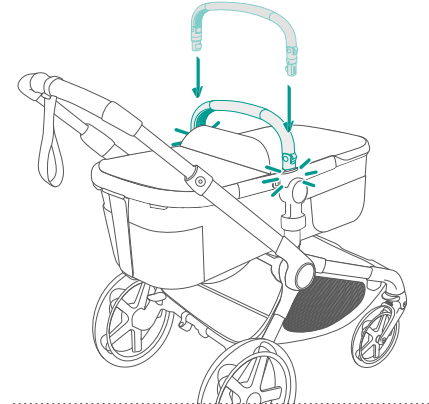

27

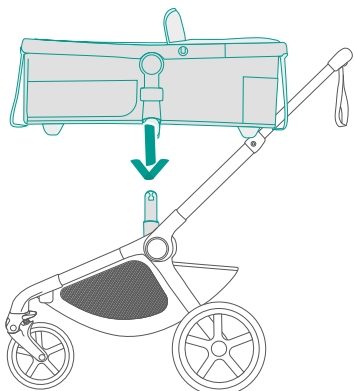

23

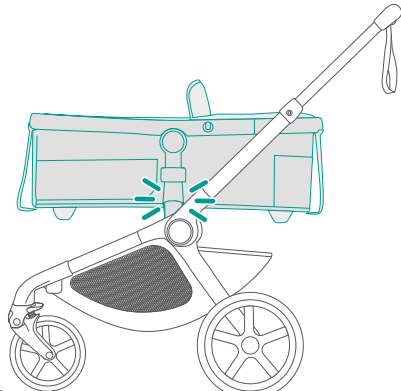

24

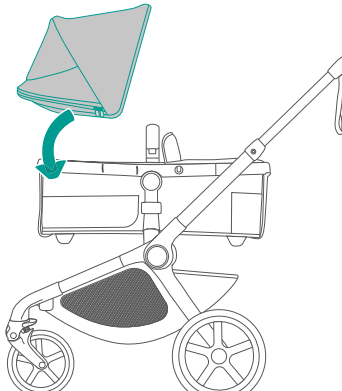

28

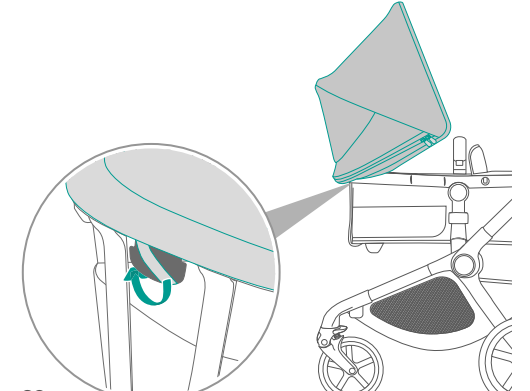

29

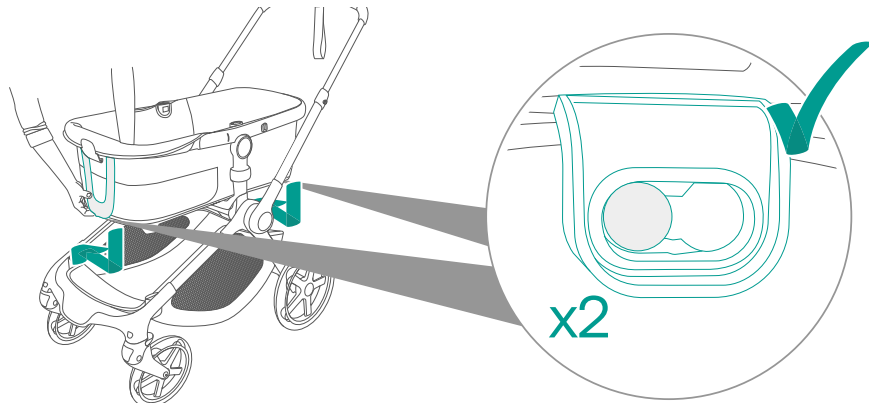

25

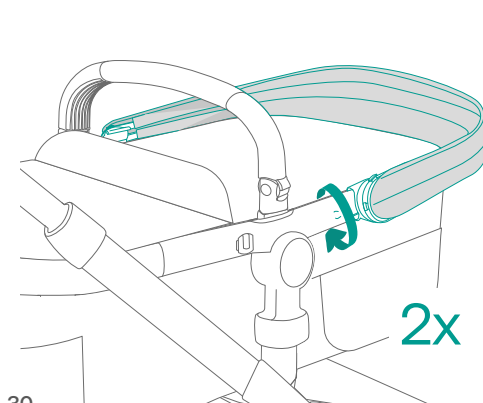

30

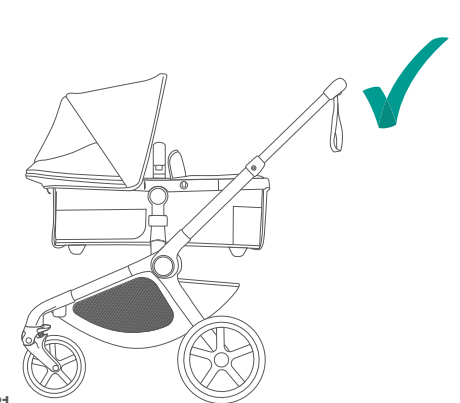

31

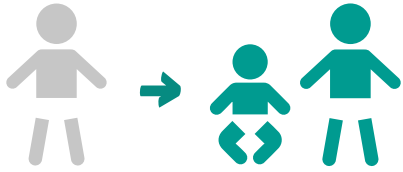

EN ⚠ **Warning symbol: refer to warnings**
Important: to use the stroller with two children, adapt the chassis to double mode.
Never leave the children unattended in the stroller.
Always use the complete five-point harness.
Ensure to give proper instructions to another care taker on how to use the product.

ES ⚠ **Símbolo de advertencia: consulte las advertencias**
Importante: para utilizar el cochecito con dos niños, adapte el chasis al modo doble.
Nunca deje a los niños solos en el cochecito.
Utilice siempre el arnés completo de cinco puntos.
Asegúrese de dar instrucciones adecuadas sobre cómo utilizar el producto a otra persona que lo utilice.

FR ⚠ **Symbole d'avertissement : se référer aux avertissements**
Important : pour utiliser la poussette avec deux enfants, adaptez le châssis en mode double.
Ne laissez jamais les enfants sans surveillance dans la poussette.
Utilisez toujours le harnais complet à cinq points.
Assurez-vous de donner les instructions appropriées à un autre soignant sur la façon d'utiliser le produit.

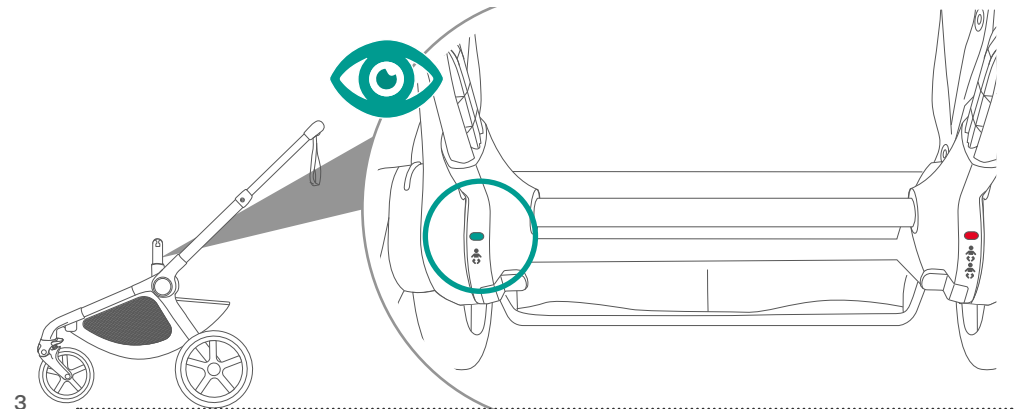
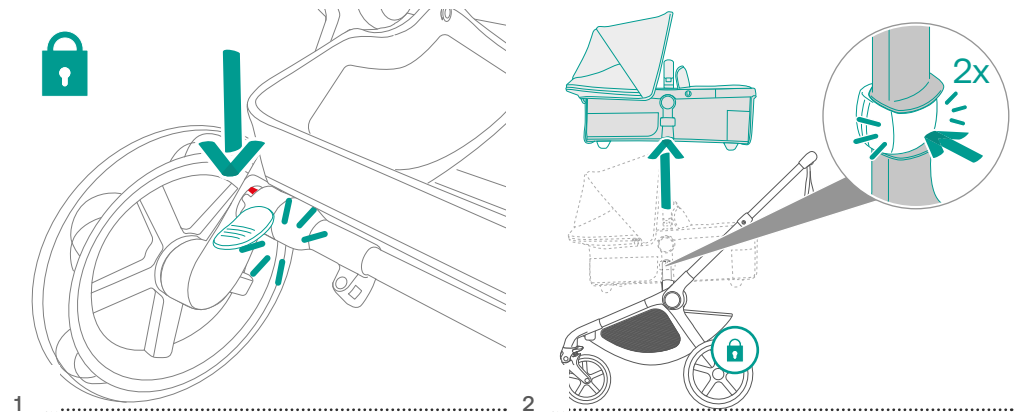
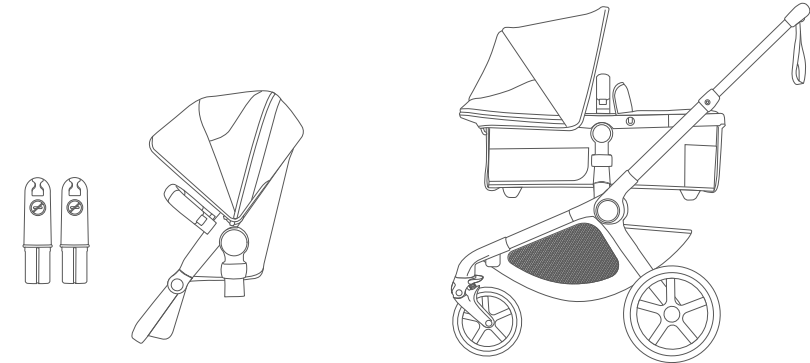

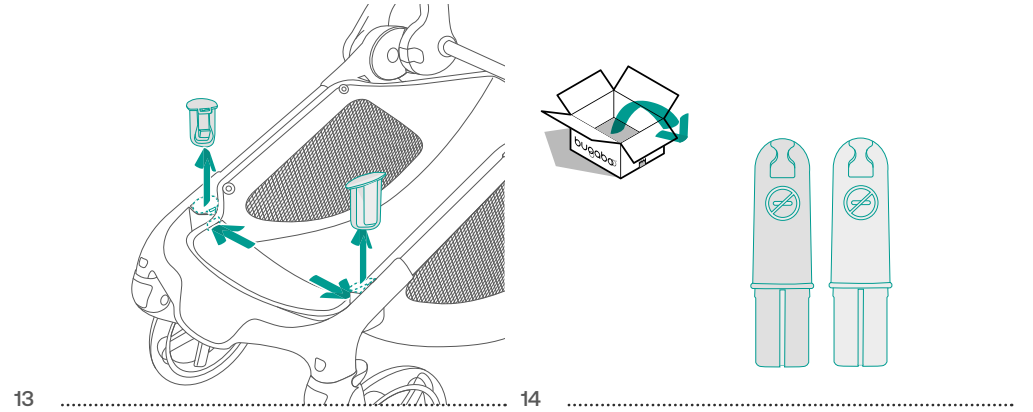
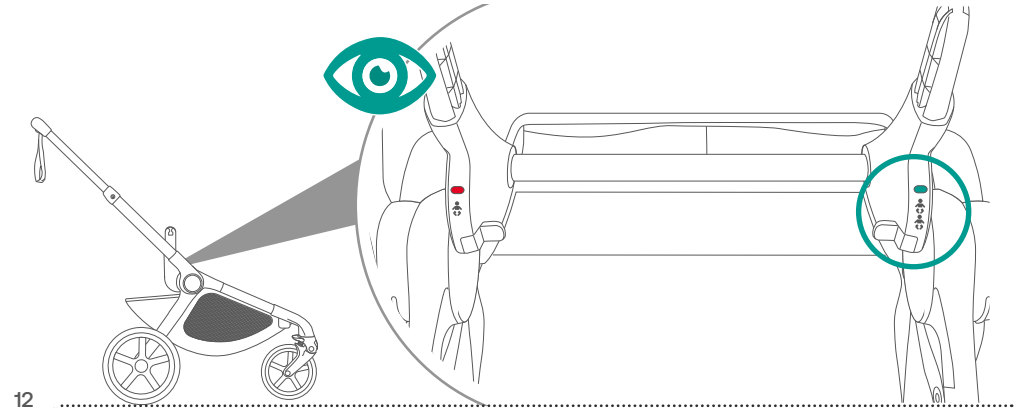
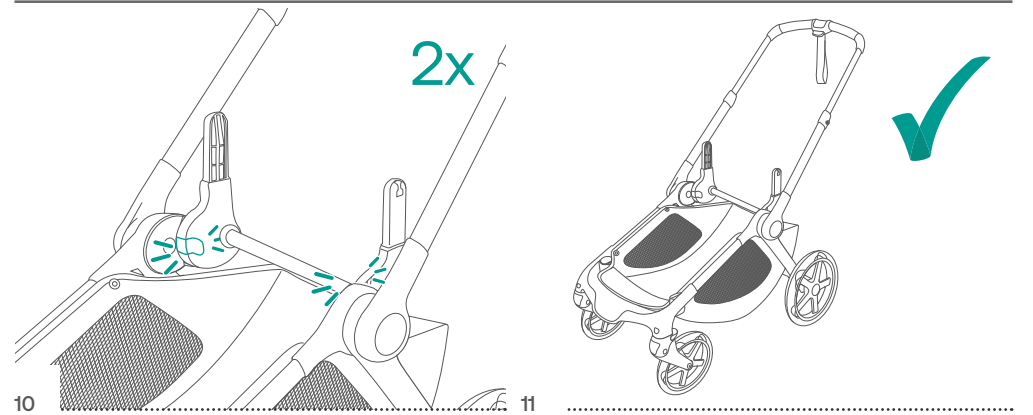
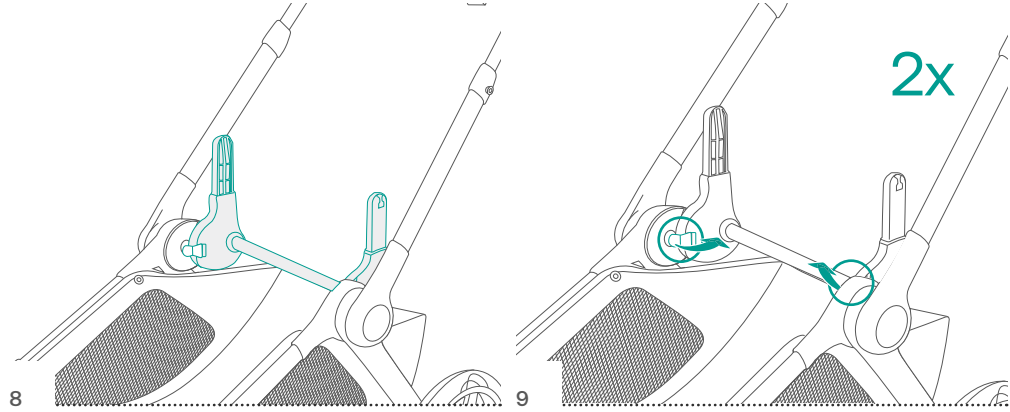
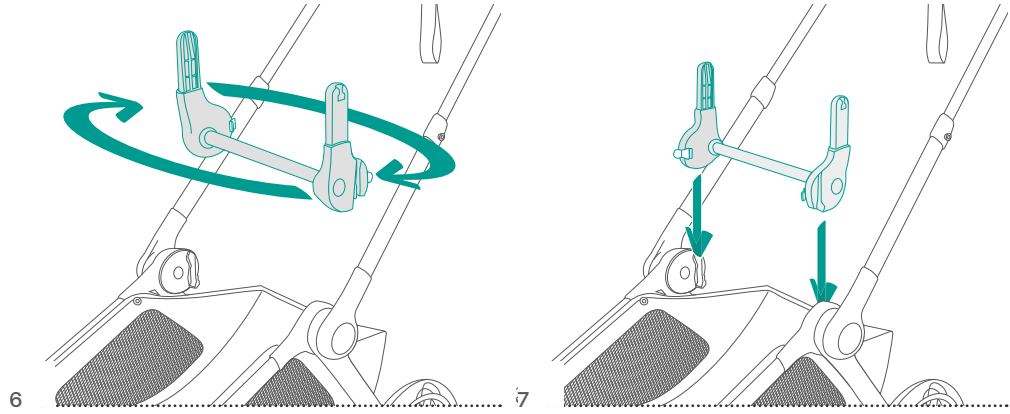
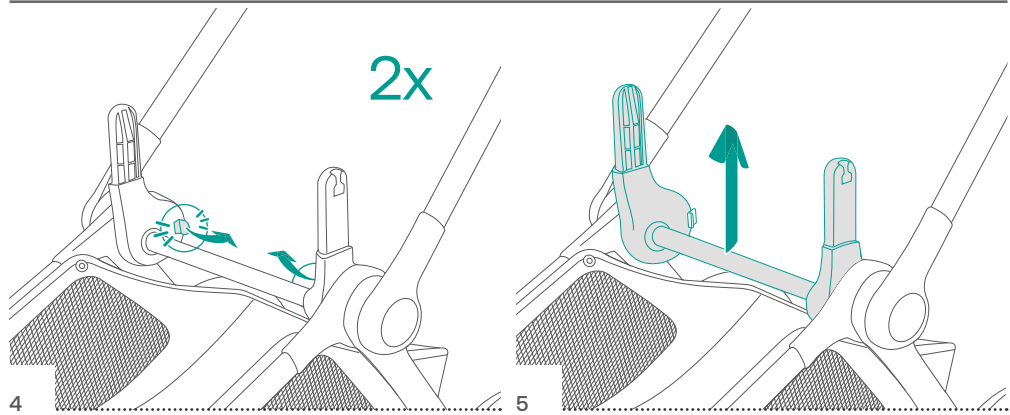

⚠ EN Always adjust the chassis to single mode and use upper position when carrying one child only.

⚠ ES Ajusta siempre el chasis al modo individual y utiliza la posición superior cuando llesves a un solo niño.

⚠ FR Veillez à toujours régler le châssis en mode simple et à utiliser la position haute lorsque vous ne transportez qu'un seul enfant.

2x

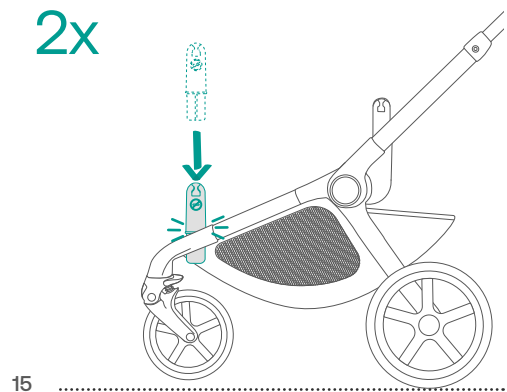

15

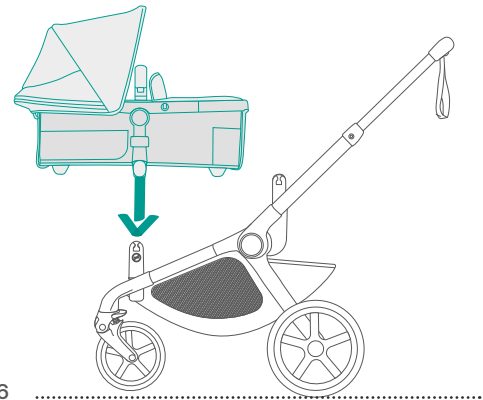

16

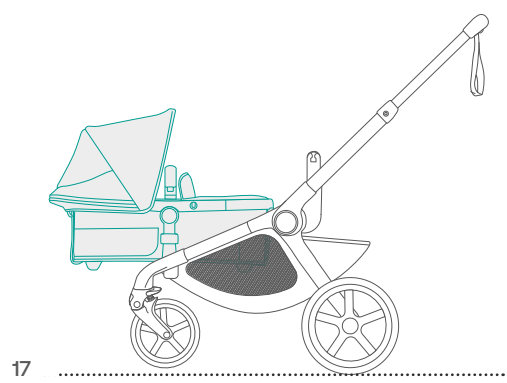

17

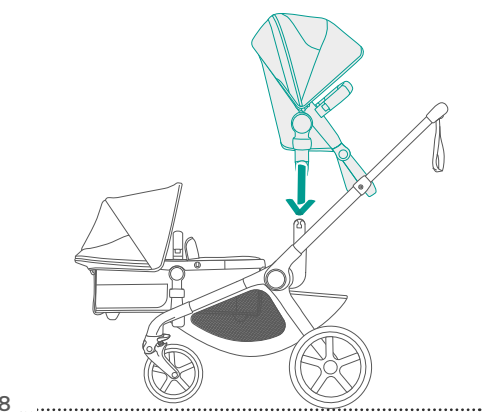

18

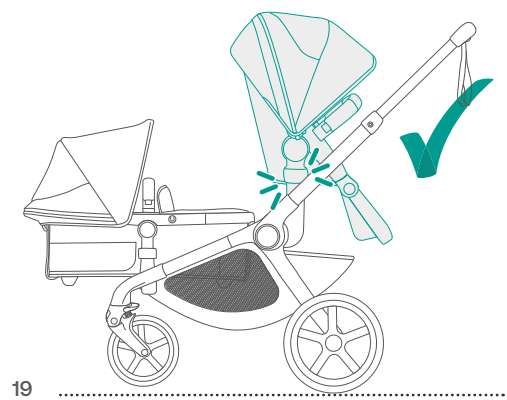

19

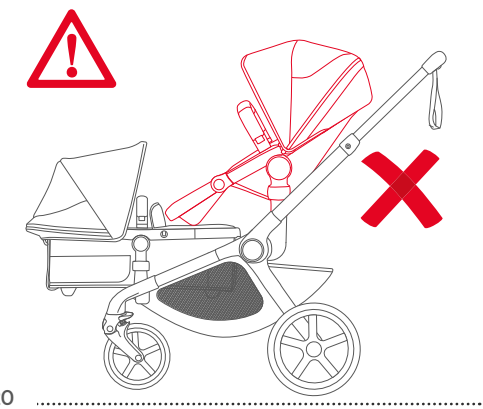

20

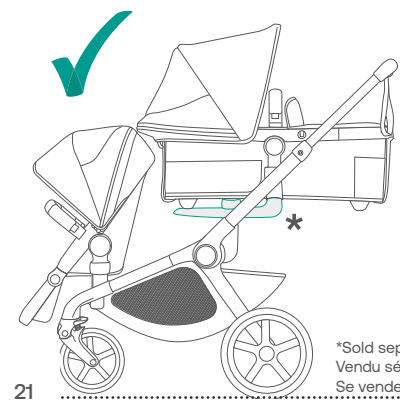

21

*Sold separately
Vendu séparément
Se vende por separado

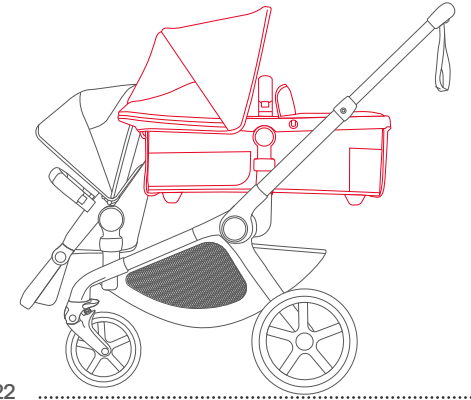

22

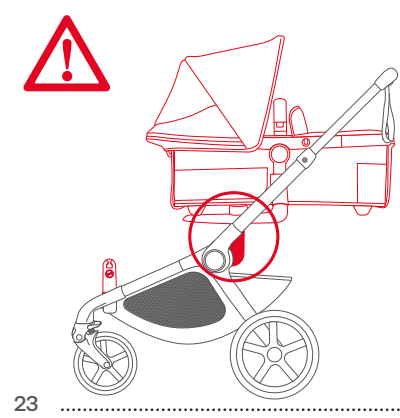

23

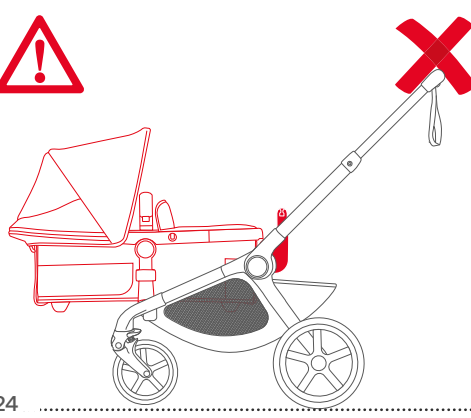

24

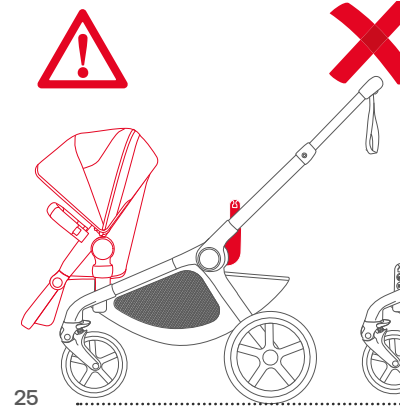

25

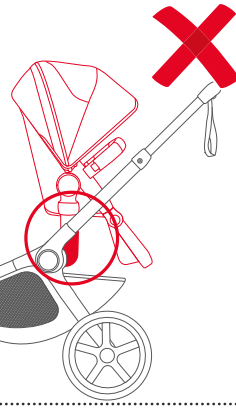
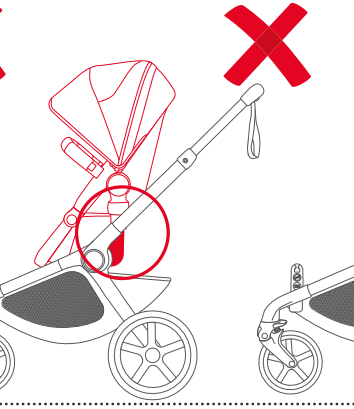

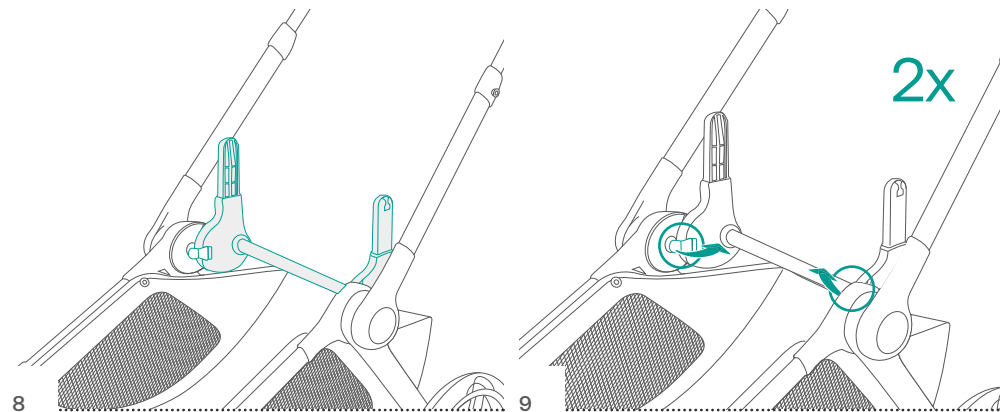
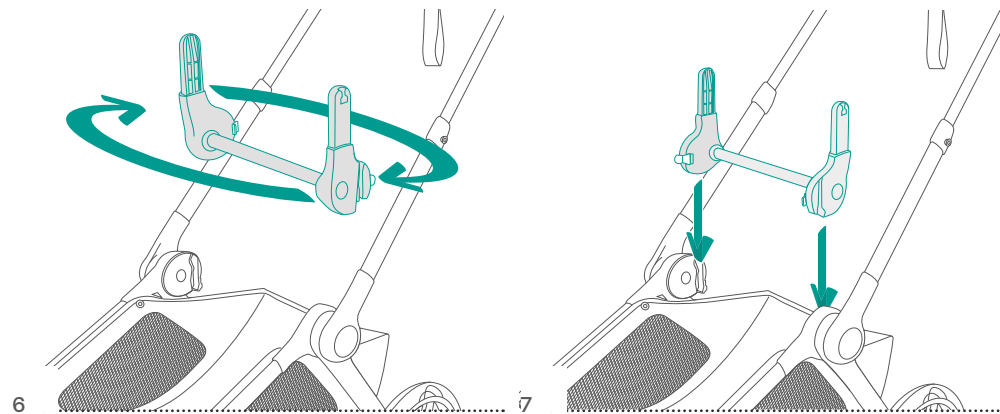
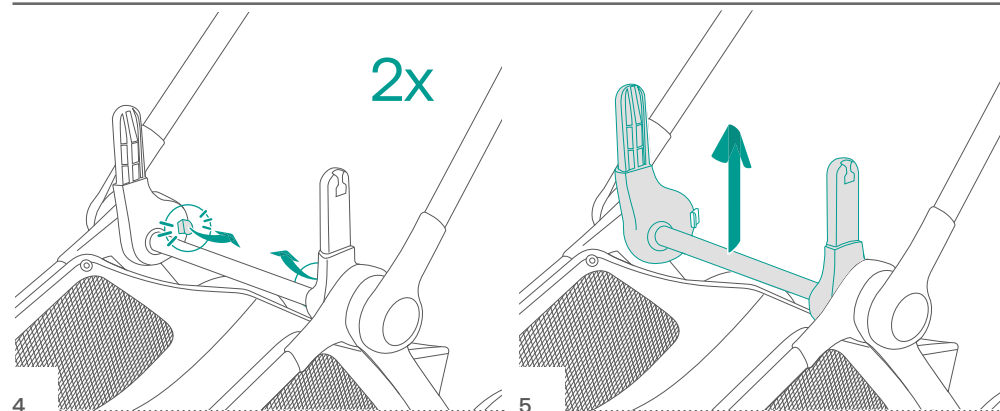
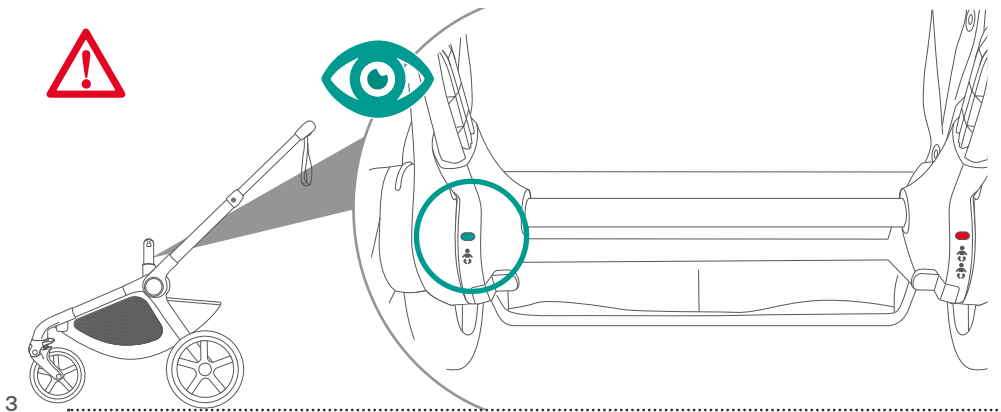
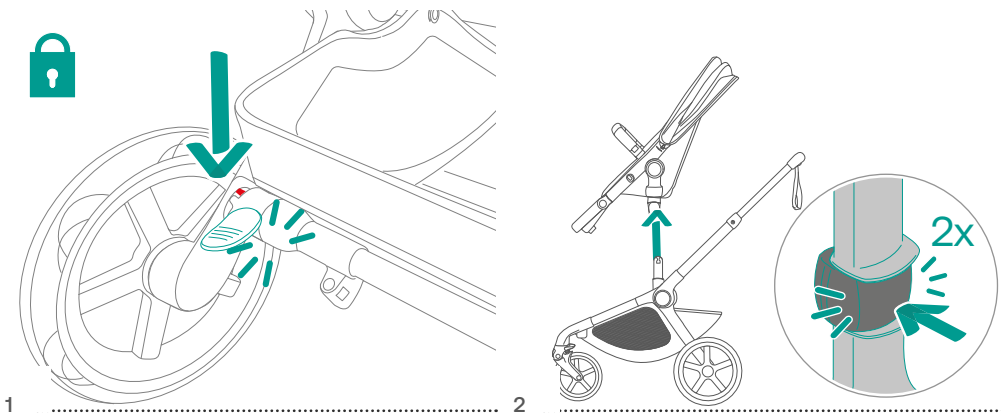
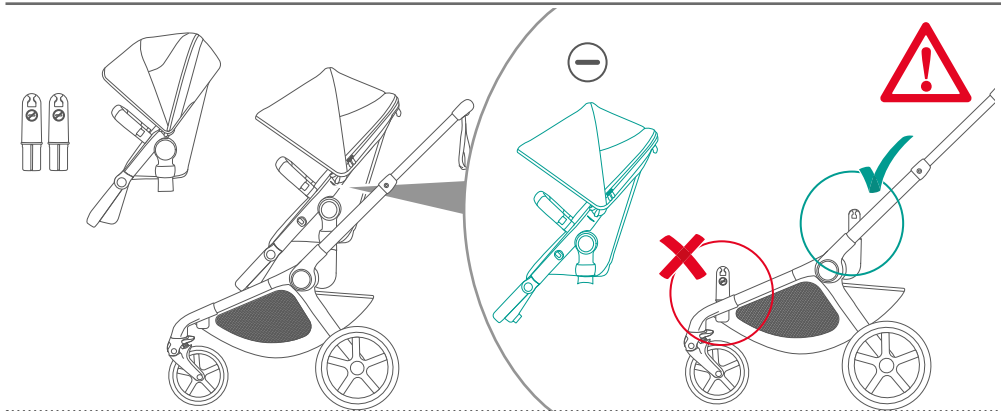

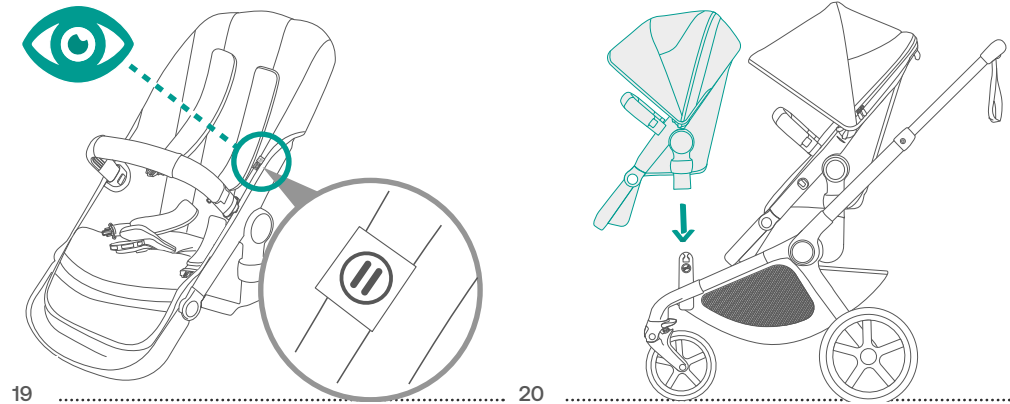
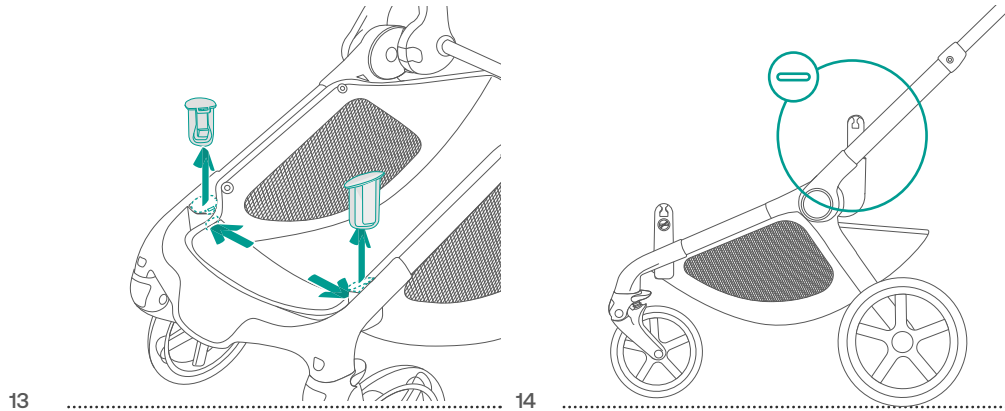
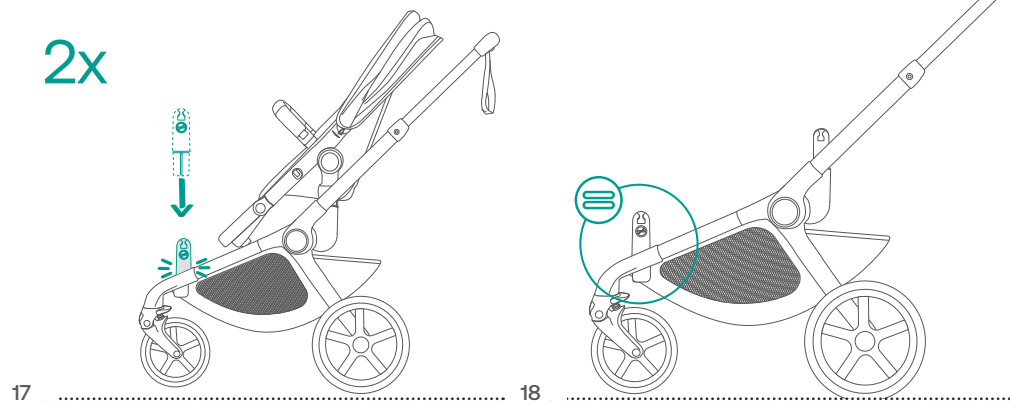
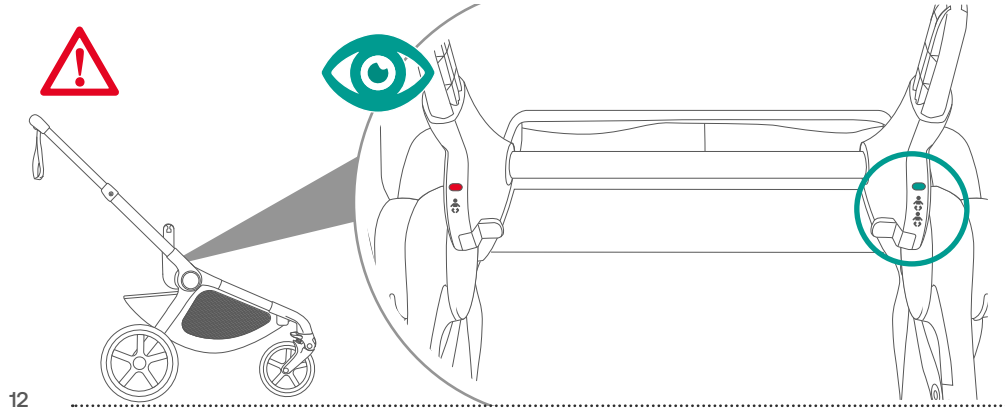
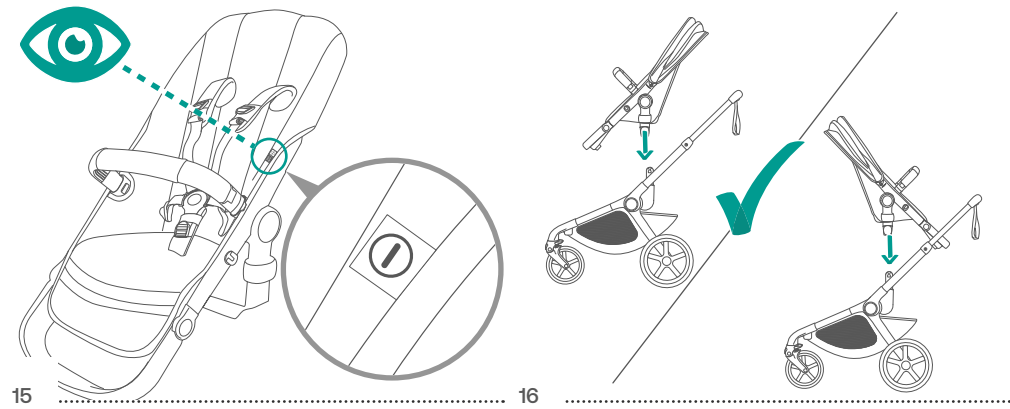
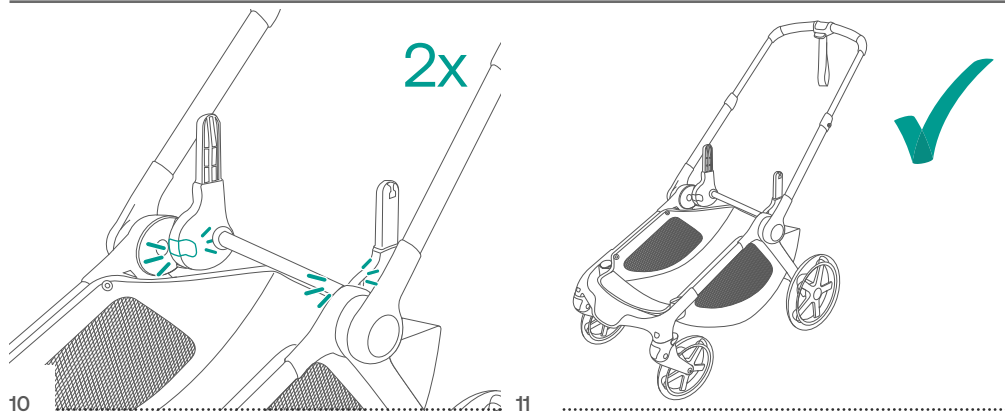

⚠ **EN** Always adjust the chassis to single mode and use upper position when carrying one child only.

⚠ **ES** Ajusta siempre el chasis al modo individual y utiliza la posición superior cuando lleves a un solo niño.

⚠ **FR** Veillez à toujours régler le châssis en mode simple et à utiliser la position haute lorsque vous ne transportez qu'un seul enfant.

ONLY USE THESE CONFIGURATIONS
UTILICE SÓLO ESTAS CONFIGURACIONES
A UTILISER UNIQUEMENT DANS CES CONFIGURATIONS

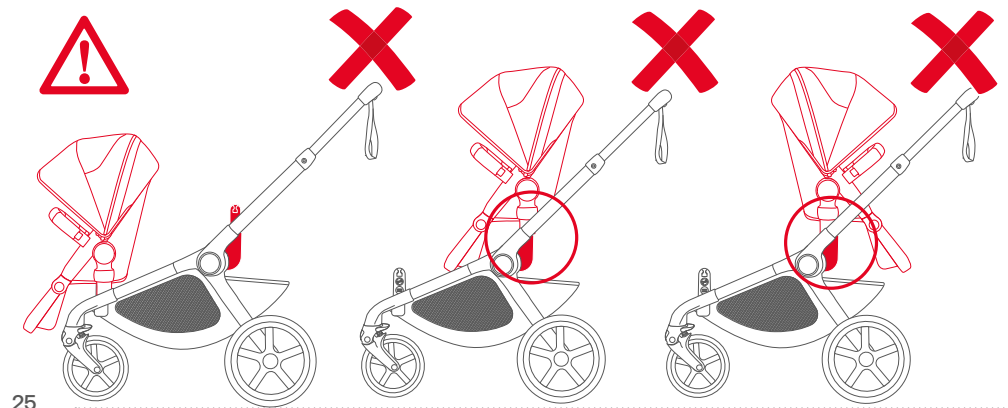
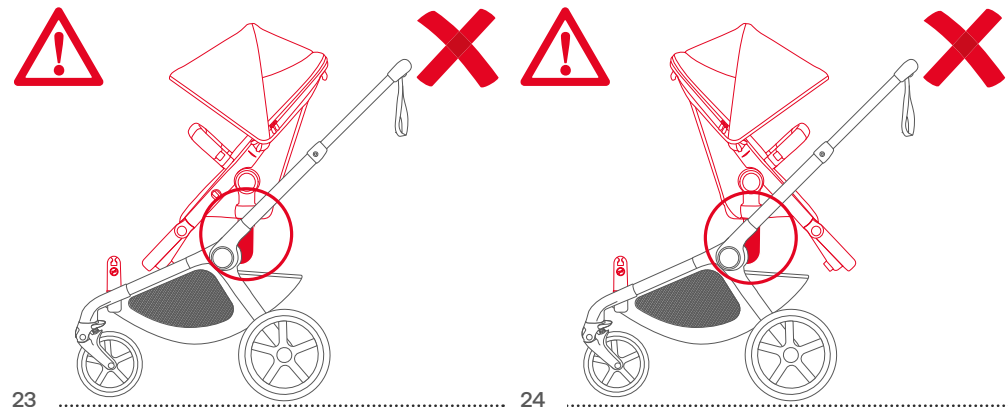
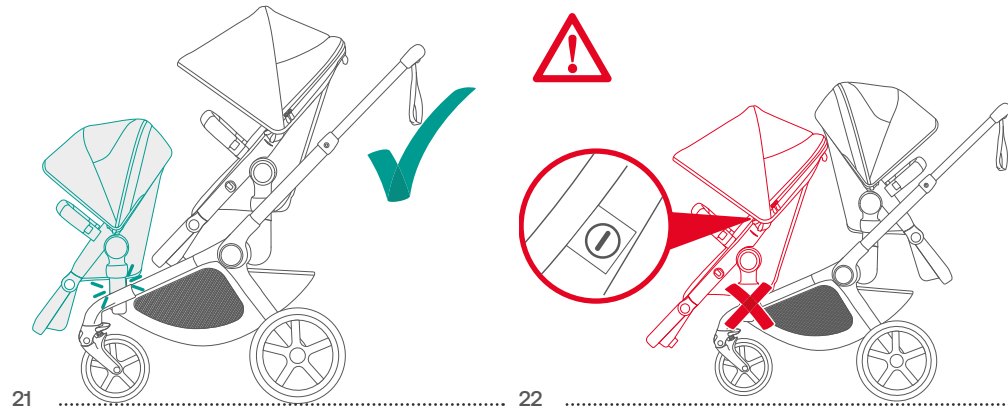

30

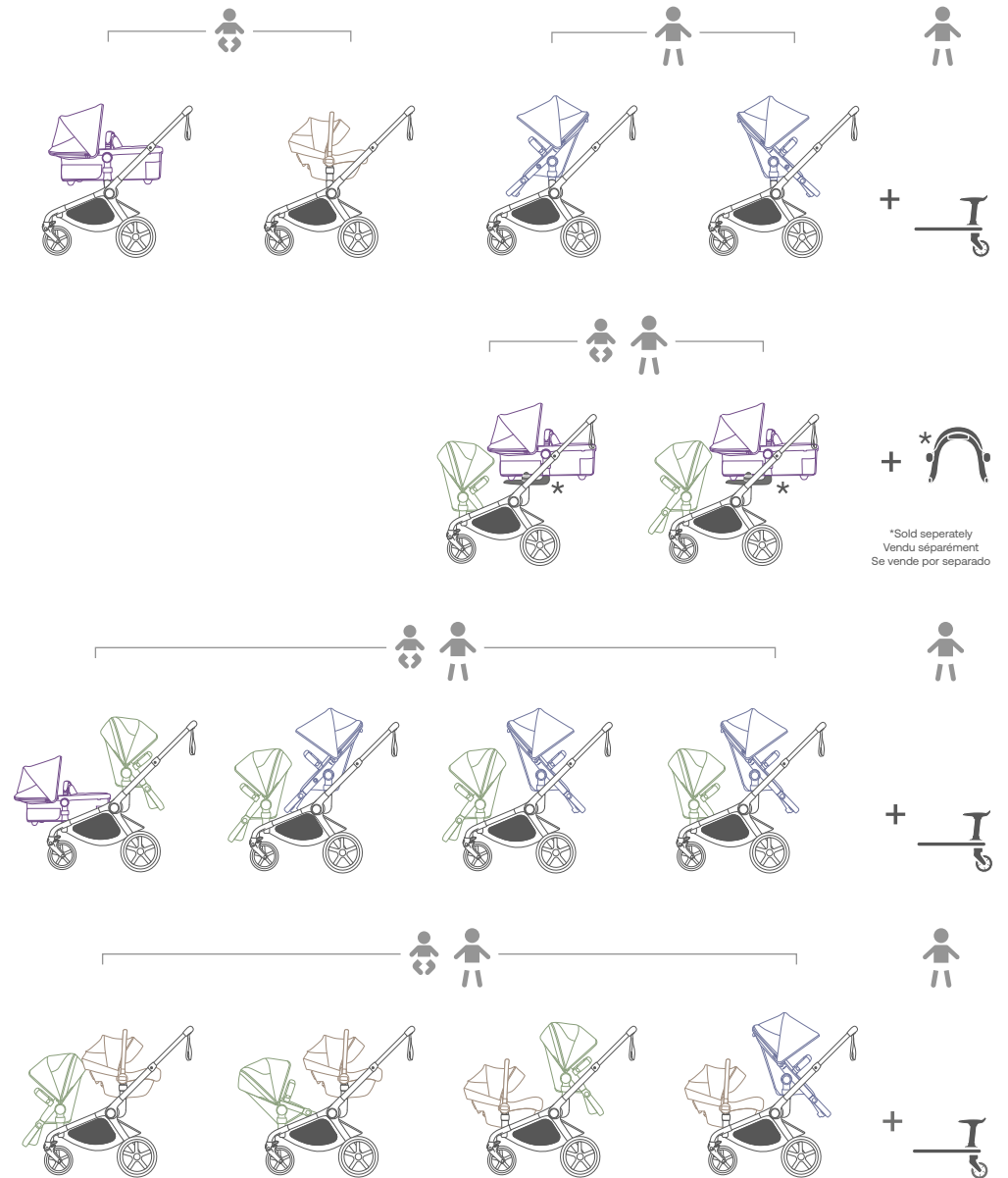

31

Features

Please pay extra attention to all the features of the Bugaboo Kangaroo. This enables you to use this product to the fullest and secures a smooth ride for you and your child.

Por favor, presta especial atención a todas las características del Bugaboo Kangaroo. Esto te permitirá sacar el máximo partido a este producto y te garantizará el paseo más suave para ti y para tu hijo.

Veillez prêter une attention particulière à toutes les caractéristiques de la Bugaboo Kangaroo. Cela vous permettra d'utiliser ce produit au maximum de ses capacités et d'assurer une conduite agréable pour vous et votre enfant.

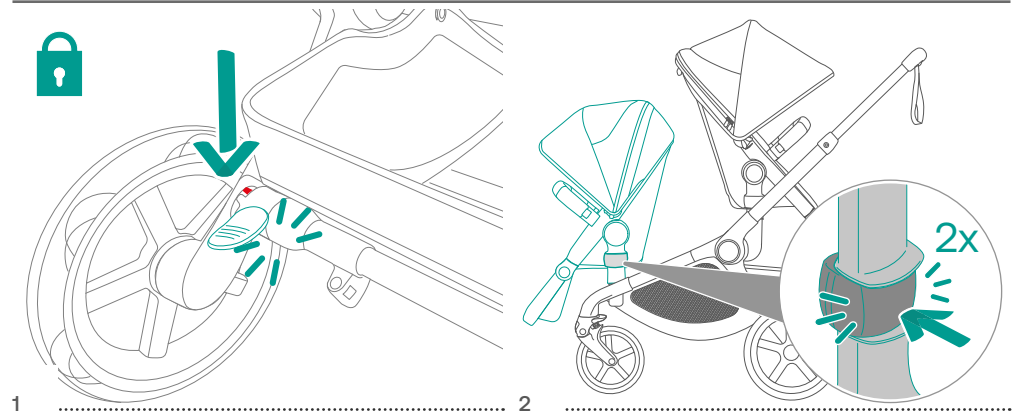

1

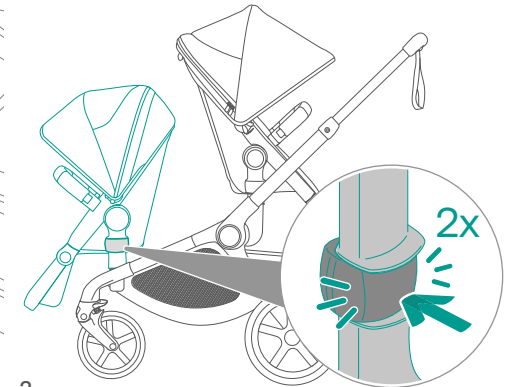

2

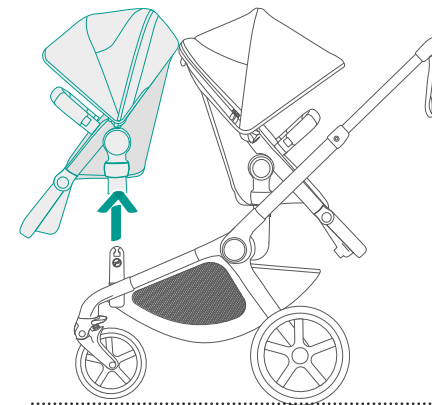

3

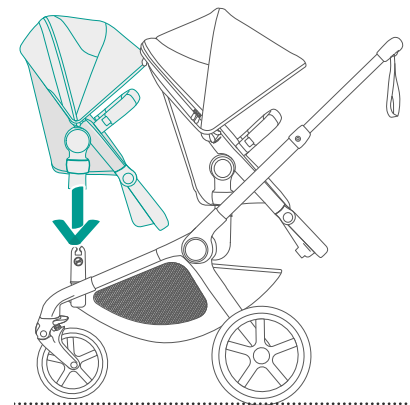

4

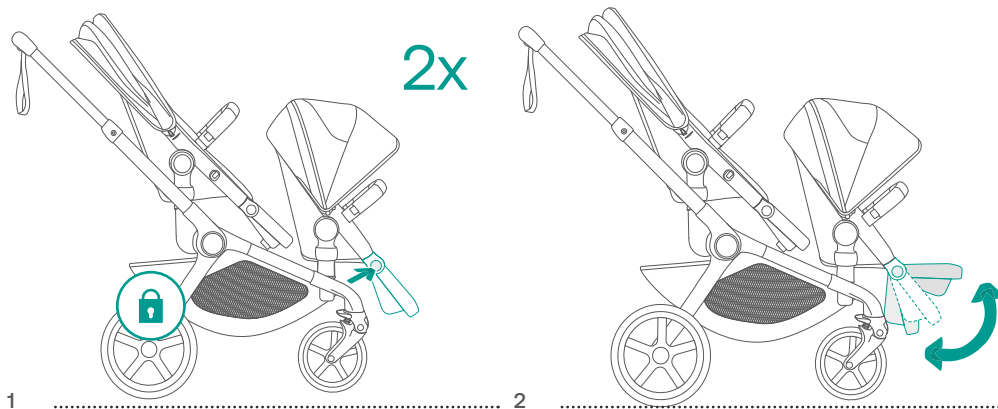

1

2x

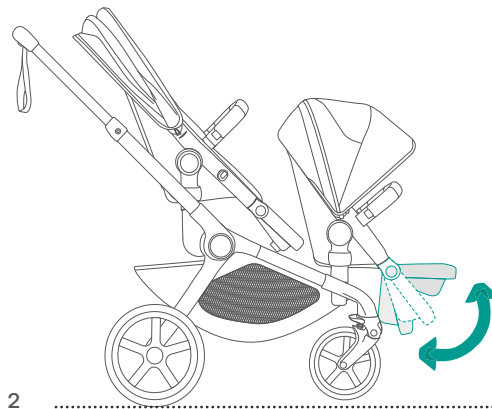

2

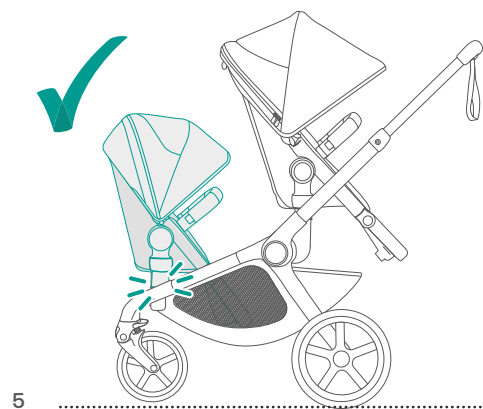

5

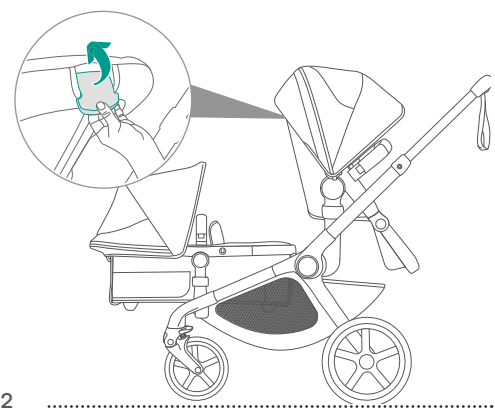
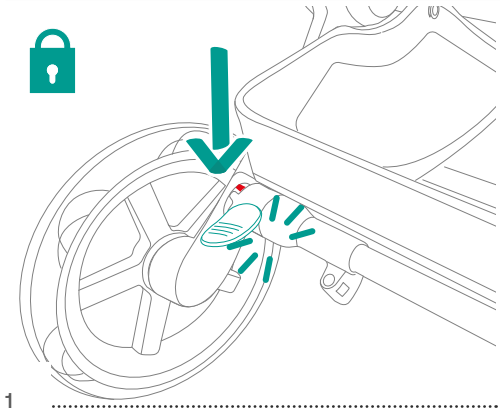

1

2

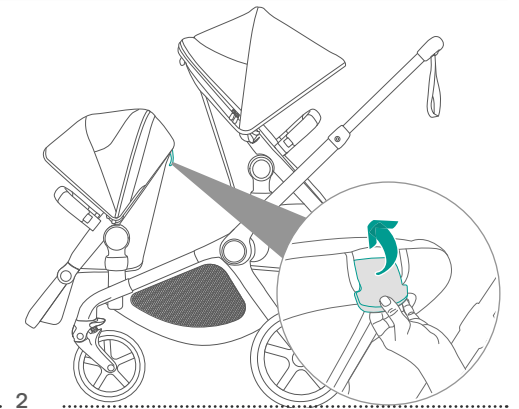
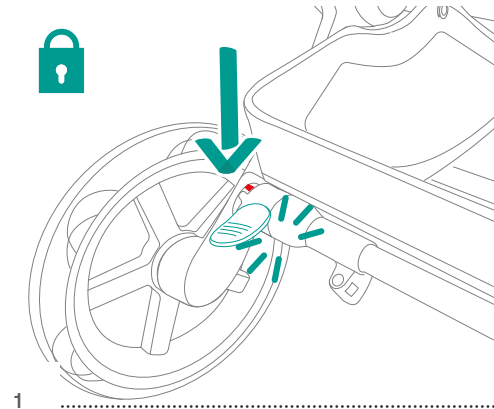

1

2

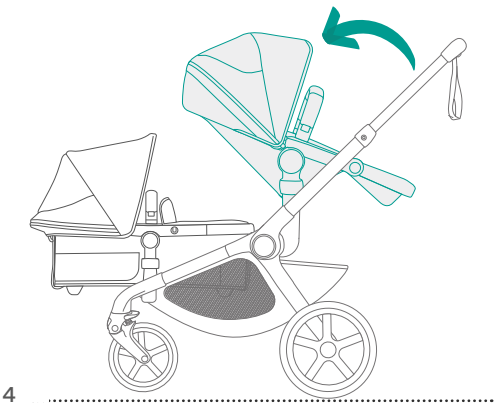
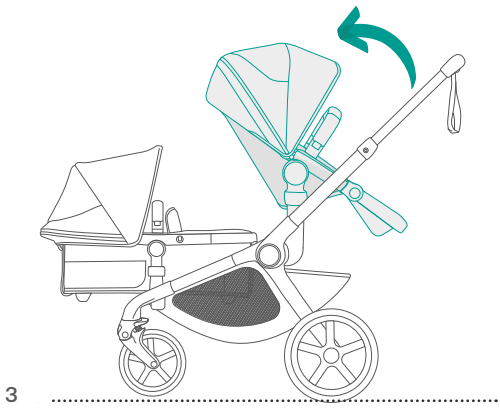

3

4

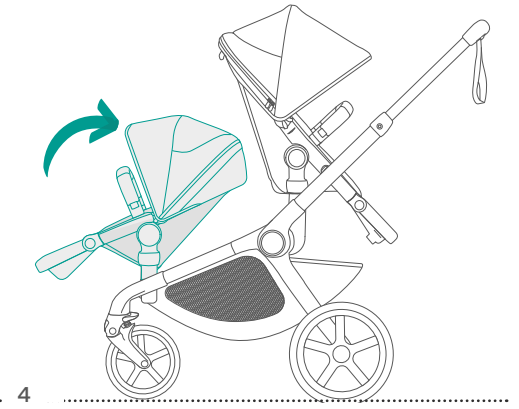
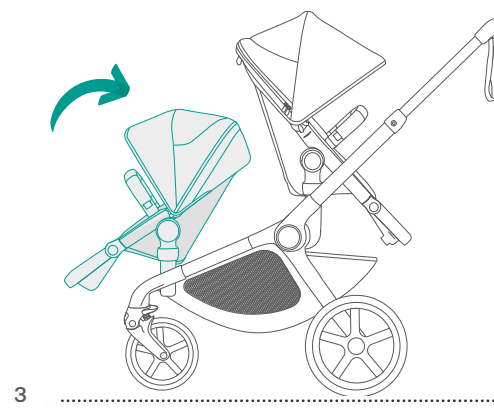

3

4

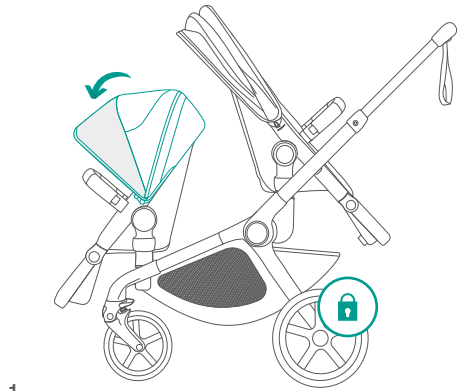

1

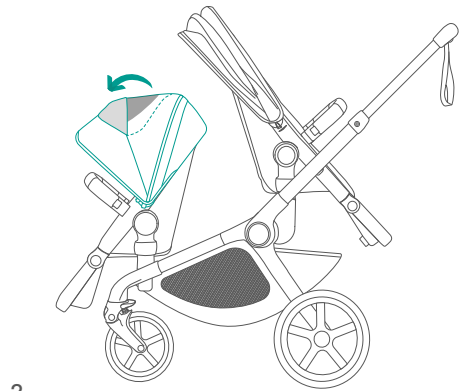

2

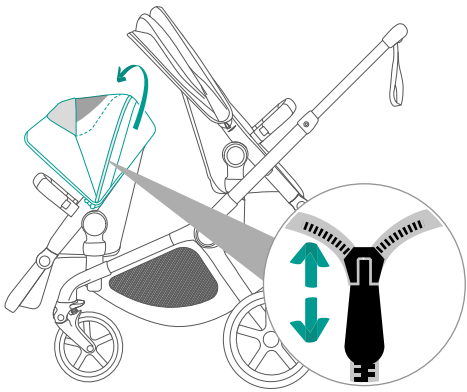

3

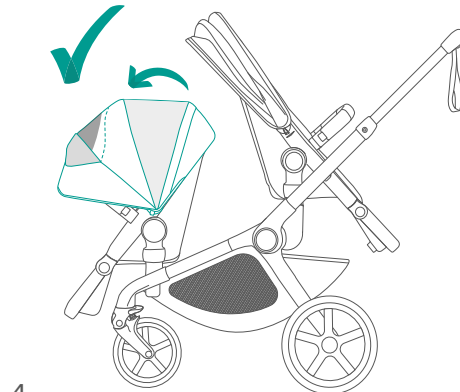

4

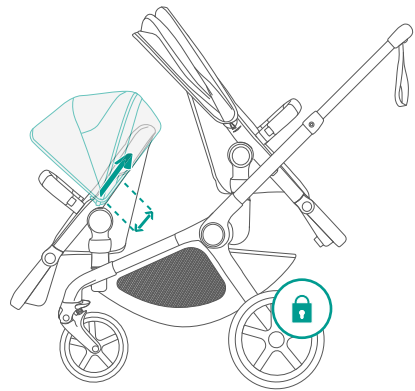

1

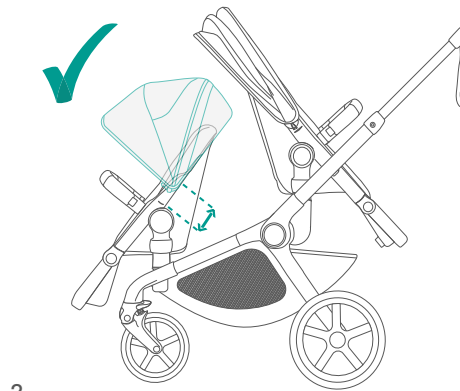

2

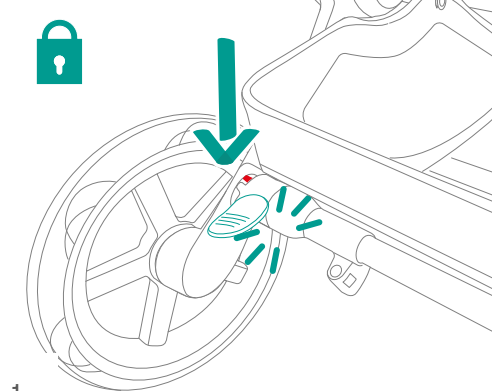

1

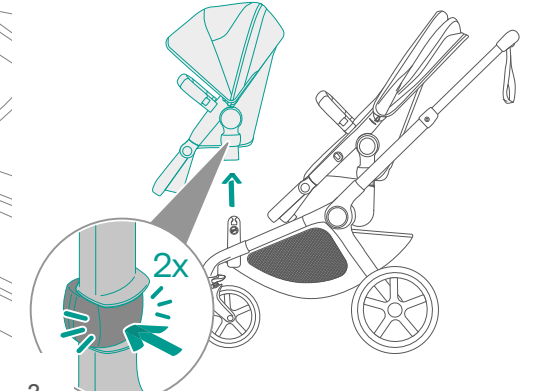

2

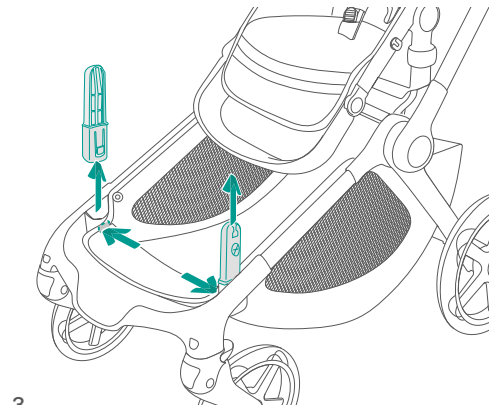

3

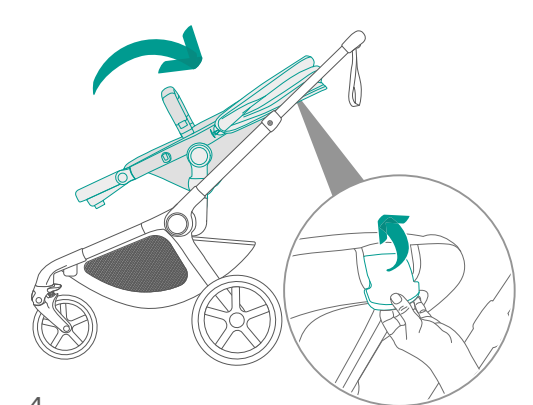

4

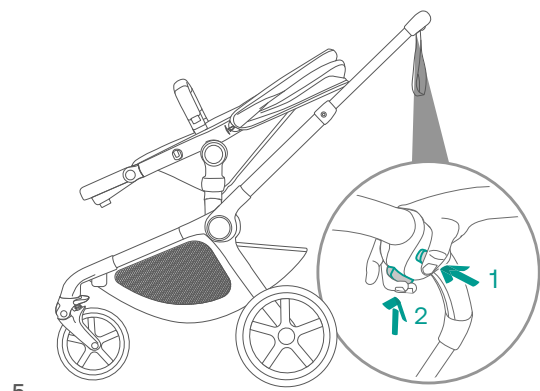

5

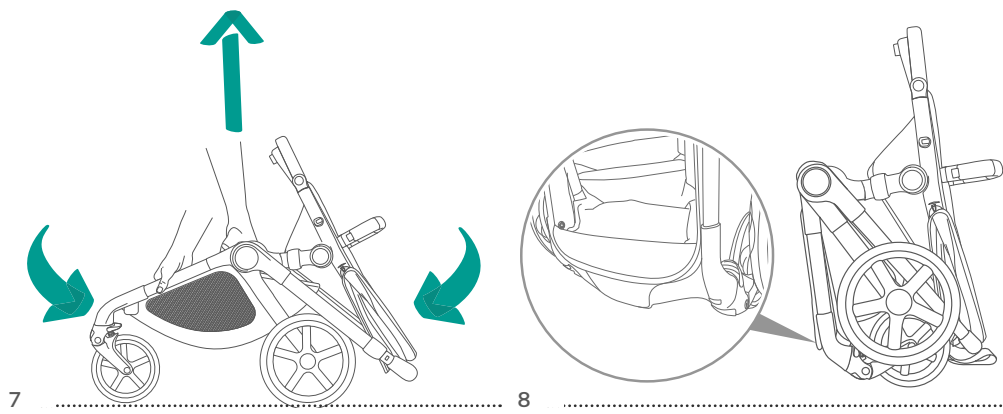
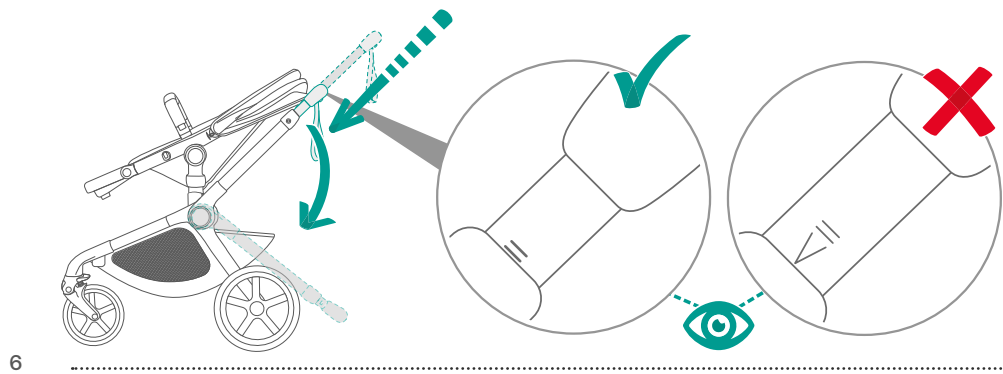

www.bugaboo.com

Bugaboo Europe & Asia

Bugaboo International B.V.
Paasheuvelweg 9 a-b
1105 BE Amsterdam Zuidoost
The Netherlands

Bugaboo North America, Inc.

142 W 57th St New York
New York 10019
United States of America

Bugaboo Australia

Bugaboo Australia Pty Limited
Service department Suite 2, Level 2
156 Edgecliff Road Woollahra, NSW 2025
Australia