

SC7541IM

Freestanding / Semi Built-in

LIEBHERR

Refrigeration and Freezing

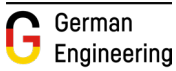

home.liebherr.com



SC7541IM	
Energy consumption (kWh / y)	386
Estimated Yearly Energy Cost in US \$	54
Sound rating dB(A)	36
Total capacity cu.ft. (l)	12.8 (363)
Refrigerator capacity cu.ft. (l)	7.9 (224)
BioFresh compartment cu. ft. (l)	-
Freezer capacity cu. ft. (l)	4.9 (139)
Electronic control	Touch display
Defrost type	Automatic
Interior light	Ceiling LED
Number of shelves	4
Number of door racks	2 + VarioBox
Number of EasyFresh drawers	1
Number of freezer drawers	3
Refrigerator Temperature range °F (°C)	34 to 46°F (2 to 9°C)
Freezer temperature range °F (°C)	5 to -15°F (-15 to -26°C)
Internal Water Dispenser	No
Water filter	No
IceMaker	Fixed water connection
Ice cube output lbs. (kg)/24h	2.6 (1.2)
Ice cube stock lbs. (kg)	11.9 (5.4)
Door hinges	Left, reversible
Product dimensions	
in inch (H / W / D)	65 3/16 / 29 7/16 / 26 5/8
in cm (H / W / D)	165.5 / 74.5 / 67.5
Cut out dimensions	
in inch (H / W / D)	66 / 30 / 24
in cm (H / W / D)	168 / 76.2 / 60.9
Net weight lbs. (kg)	198.4 (90)
Voltage V / Hz	115/60

This model can be installed Side-by-side with SC7520 along with the original door swing

* Energy Cost will depend on utility rates and use. Estimated energy cost based on a national average electricity cost of 14 cents per kWh.

** Noise output – according to EN 60704-3

Accessories

FreshAir activated carbon filter	9882460
Side By Side Kit	9905353
60" Top Ventilation grill for Side by Side Installation	9904409

Features

Duo Cooling

DuoCooling independent refrigeration systems provide precise temperature control and superior performance, efficiency and food preservation.

Easy Fresh

The guarantee of market freshness in your home. Whether it's unpackaged vegetables or fruit, Easy Fresh ensures that your food is preserved for a longer period of time.

Power Cooling

The fan – as powerful as it is quiet – distributes the cold air efficiently throughout the entire refrigeration compartment.

Ice Maker

Liebherr's automatic IceMaker produces perfect ice cubes and keeps a constant supply on hand for every occasion.

LED

The energy efficient LED ceiling light not only emits virtually no heat for the optimal storage of wines, but is dimmable for a pleasant ambient light within the cabinet, as well as a cool glow for the room.

Super Silent

Noise levels are kept to a minimum thanks to virtually silent, speed-controlled, and sound absorbing compressors.

Smart Steel

SmartSteel finish significantly reduces the visibility of fingerprints, is easy to clean, and is scratch resistant.

Smart Device Box

Want to be prepared for the future of the Smart Home? The SmartDeviceBox can be installed in just a few steps and will open up the whole world of digital possibilities to you today.

Diagrams

Product Dimensions

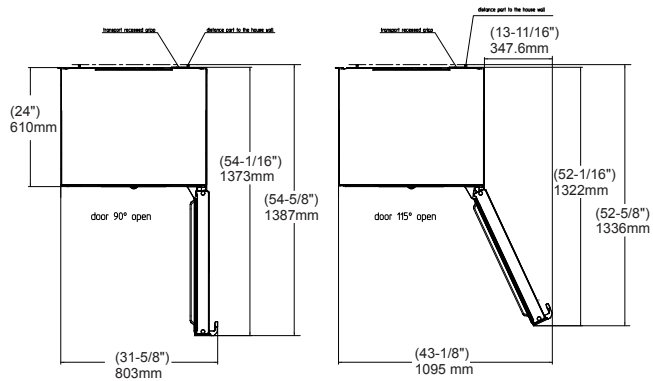
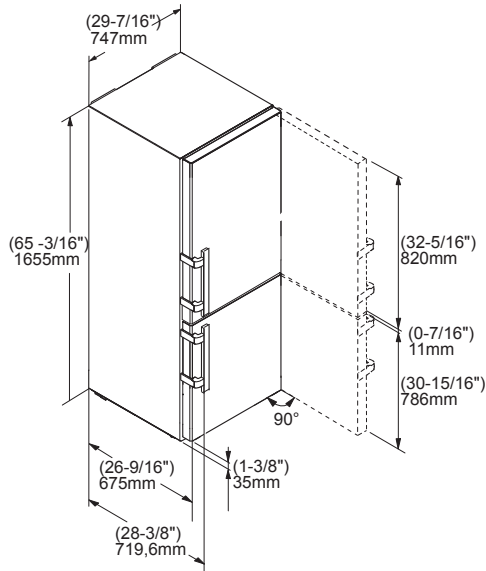

Allow door swing clearance at locations next to a wall. If the appliance is installed with the hinges next to a wall (4), the distance between the appliance and the wall must be at least 1 1/2" (40mm). This is how far the handle protrudes when the door is open. The refrigerator door must open to a minimum of 90° to allow the crispers to open and the shelves to be removed. There is no 90° door limiter available for this model. Height can be increased by 3/8" (10mm) by turning the levelling feet at the front and the height adjustable rollers at the appliance rear.

Semi built-in look – Cutout Dimensions

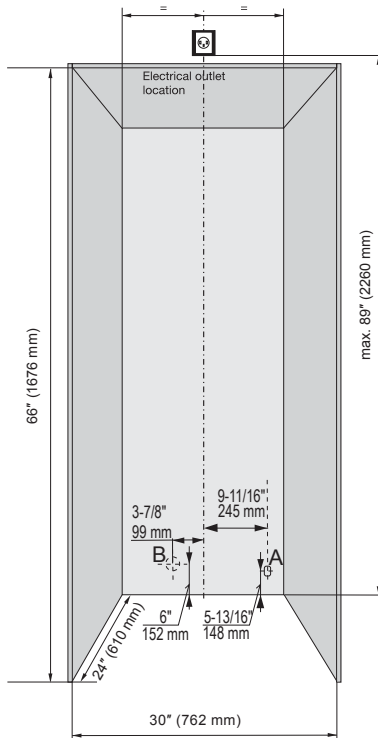

The appliances can be used freestanding or semi built-in. If semi built-in, consider the minimum cabinet opening dimensions specified on this image.

The power cord exists the rear of the appliances (A) right side and has a length of 6.5 ft (2m). We suggest the electrical outlet not to be located behind the appliance, so it is easily accessible. This can be located on top of the niche like shown on the image.

Do not install the shut-off valve for the water supply behind the appliance, to allow access to shut off without having to pull out the appliance. The water line lead out position is according to graphic (B).

Ventilation Requirements

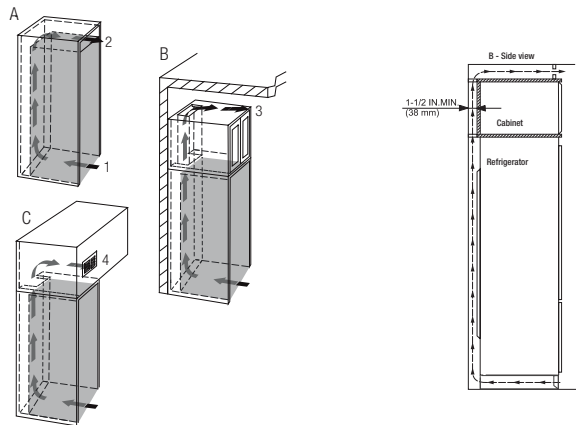

If the appliance is integrated in a fitted kitchen, the following ventilation requirements must be met: - The spacing fins on the back of the appliance are used to ensure sufficient ventilation. These must not lie in cavities or recesses in their final installation position. - Basically, the larger the ventilation gap, the more energy the appliance saves during operation. Do not restrict the air flow.

A cross-sectional air flow of at least 31 in² (200cm²) per appliance at the airflow inlet (1) and at the airflow outlet (2).

The top ventilation space can be directed in one of the following ways:

- A. Directly over the appliance (2) with a gap between the ceiling of the unit and the cabinet
- B. Above the cabinet and below the ceiling (3).
- C. Through a vent installed in a soffit (4).

Be sure to consider the possibility of having to raise some of the leveling legs in order to level the appliance when installing. If you adjust the height of the appliance – it will effectively reduce air flow. Therefore leave yourself some room for adjustment. The appliance is designed to allow proper air flow when installed up against the wall.