

R11 Meta

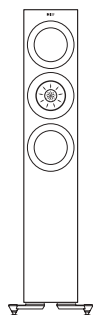

R7 Meta

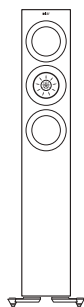

R5 Meta



R3 Meta

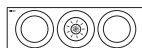

R6 Meta



R2 Meta



R8 Meta

User Manual

R Series

Table of Contents

1. Introduction	4
1.1 Signal Symbol/Word Definitions	4
2. Unboxing	5
2.1 R2 Meta / R3 Meta / R6 Meta / R8 Meta	5
2.2 R5 Meta / R7 Meta / R11 Meta	5
3. In the Box	6
3.1 R3 Meta	6
3.2 R2 Meta / R6 Meta	6
3.3 R5 Meta / R7 Meta / R11 Meta	7
3.4 R8 Meta	8
4. Loudspeaker Installation	9
4.1 Installing the Rubber Feet	9
4.1.1 R3 Meta	9
4.1.2 R8 Meta	9
4.1.3 R2 Meta / R6 Meta	9
4.2 Installing the Plinths	10
4.2.1 R5 Meta / R7 Meta / R11 Meta	10
4.3 Installing Floorstanding Loudspeakers	11
4.4 Installing Bookshelf Loudspeakers	11
4.5 Installing Centre Loudspeakers	12
4.6 Installing R8 Meta on other speakers	12
4.7 Installing R8 Meta on a Wall	13
5. Loudspeaker Positioning	15
5.1 Listening Space and Uni-Q Driver Array	15
5.2 Importance of Positioning Your Loudspeakers	15
5.3 Setting up Your Loudspeakers	16
5.3.1 Stereo System	16
5.3.1.1 Positioning Stereo System	17
5.3.2 Home Theatre System	18
5.3.2.1 Positioning a 5.2 or 7.2 System	19
5.3.2.2 Positioning a 5.1.4 System	20
5.3.2.3 Positioning a 7.1.4 System	21
5.4 Positioning in Irregular Rooms	22
5.5 Managing Room Modes	24
6. Connections	25
6.1 Single Wire or Bi-Wire Connections	25
6.2 Bi-Amplification	26
6.3 Making Connections	26
6.3.1 R3 Meta / R5 Meta / R7 Meta / R11 Meta	26
6.3.2 R2 Meta / R6 Meta	27
6.3.3 R8 Meta	27
6.4 Cable Gauge and Length	28
7. Fine Tuning	29
7.1 Port Bungs	29
7.2 Using Customised Feet	30

- 8. Running In31**
- 9. Care and Maintenance.....32**
 - 9.1 Cleaning the Loudspeakers.....32
 - 9.2 Use and Storage of Microfibre Grilles.....32
 - 9.3 Cleaning the Microfibre Grilles.....32
- 10. Disposal33**
 - 10.1 Disposing of the Packaging.....33
 - 10.2 Disposing of the Loudspeakers.....33
- 11. FAQ and Troubleshooting 34**
 - 11.1 General.....34
 - 11.2 Floorstanding Loudspeakers.....34
 - 11.3 Loudspeakers on Bookshelves or Stands.....34
 - 11.4 LCR (Left/Centre/Right Channel).....35
 - 11.5 Dolby Atmos Loudspeakers.....35
 - 11.6 Care and Maintenance.....35
- 12. Appendix.....37**
 - 12.1 Specifications37
 - 12.2 Dimensional Drawings.....44

1. Introduction

Thank you for choosing KEF R Series Hi-Fi Loudspeakers.

The R series includes seven loudspeaker models, each designed and engineered to produce sound with exquisite detail and incredible insight.

Blending craftsmanship, innovation, and the award-winning Metamaterial Absorption Technology (MAT), the R series makes high performance audio more versatile and accessible than ever – whether in stereo for music or in a home theatre setup.

Please read and follow this user manual carefully before using the loudspeaker systems.

1.1 Signal Symbol/Word Definitions

The following symbols and signal words are used in this user manual.

 WARNING!	This signal symbol/word designates a hazard with moderate risk, which may result in death or severe injury if not avoided.
--	--

NOTICE!	This signal word warns of possible damage to property.
----------------	--



	This symbol provides you with useful additional information on handling and use.
--	--

2. Unboxing

NOTICE!

Risk of damage!

Improper handling of the loudspeakers may result in damage.

- Pay extra attention not to touch or push on the loudspeaker drivers (cones) in the process.

Follow the instructions below to unbox the loudspeakers.

2.1 R2 Meta / R3 Meta / R6 Meta / R8 Meta

1. Place the loudspeaker carton box on the floor or on a stable surface.
2. Slice open the sealing tape on the top end. Take out the printed materials and the port bungs (R3 Meta only).
3. To take out the loudspeaker, you may choose to remove the top protective cap and take the loudspeaker out of the carton box from the top, or keep the top protective cap intact and flip the carton box upside down on the long side.

2.2 R5 Meta / R7 Meta / R11 Meta

1. Place the loudspeaker carton box horizontally flat on the floor with the plastic clip side on top. Slice open the sealing tape on both ends of the carton box and remove the plastic clips on the side.
2. Fully open the carton box to reveal the internal packaging. Take out the loudspeaker grille box (on the side), the port bungs and the supporting paper corner protectors on all the long sides.
3. Flip the loudspeaker upside down with the accessory box on top. Take out the accessory box and check the contents.

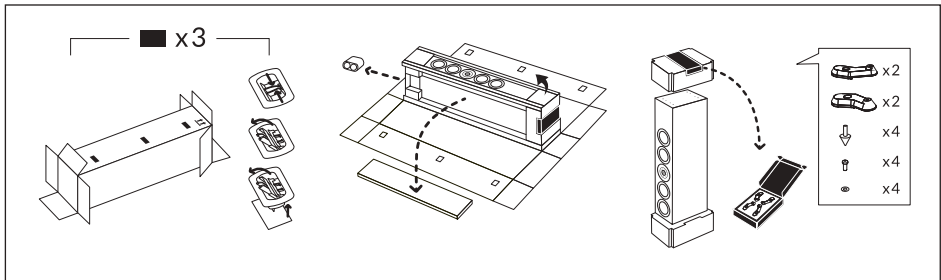

3. In the Box

3.1 R3 Meta

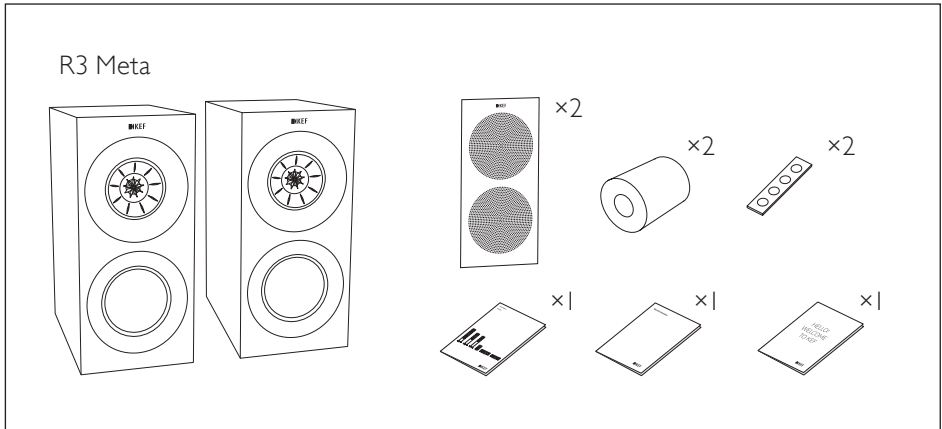

3.2 R2 Meta / R6 Meta

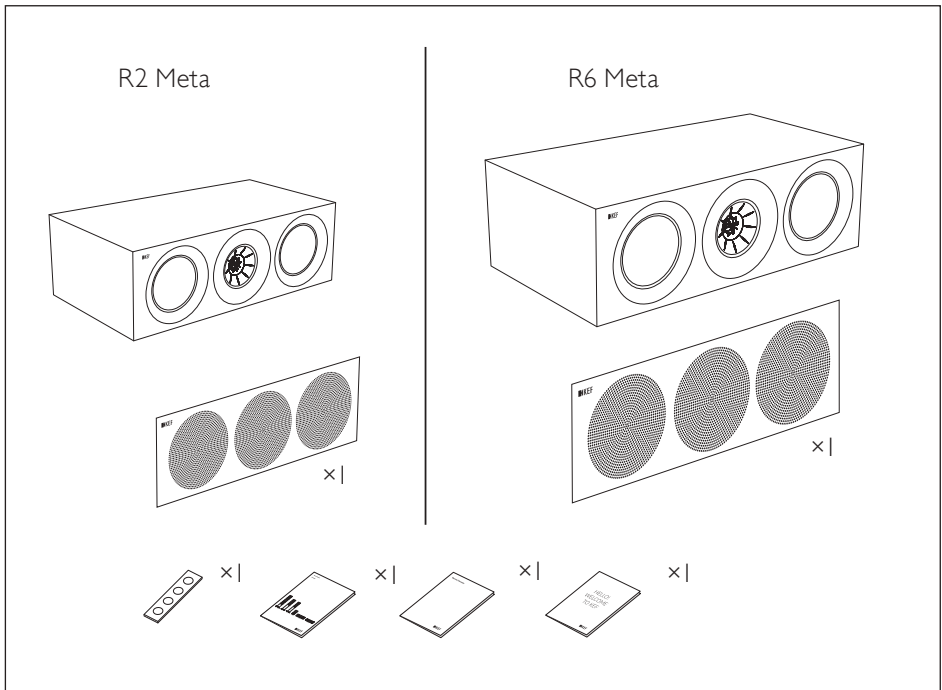

3.3 R5 Meta / R7 Meta / R11 Meta

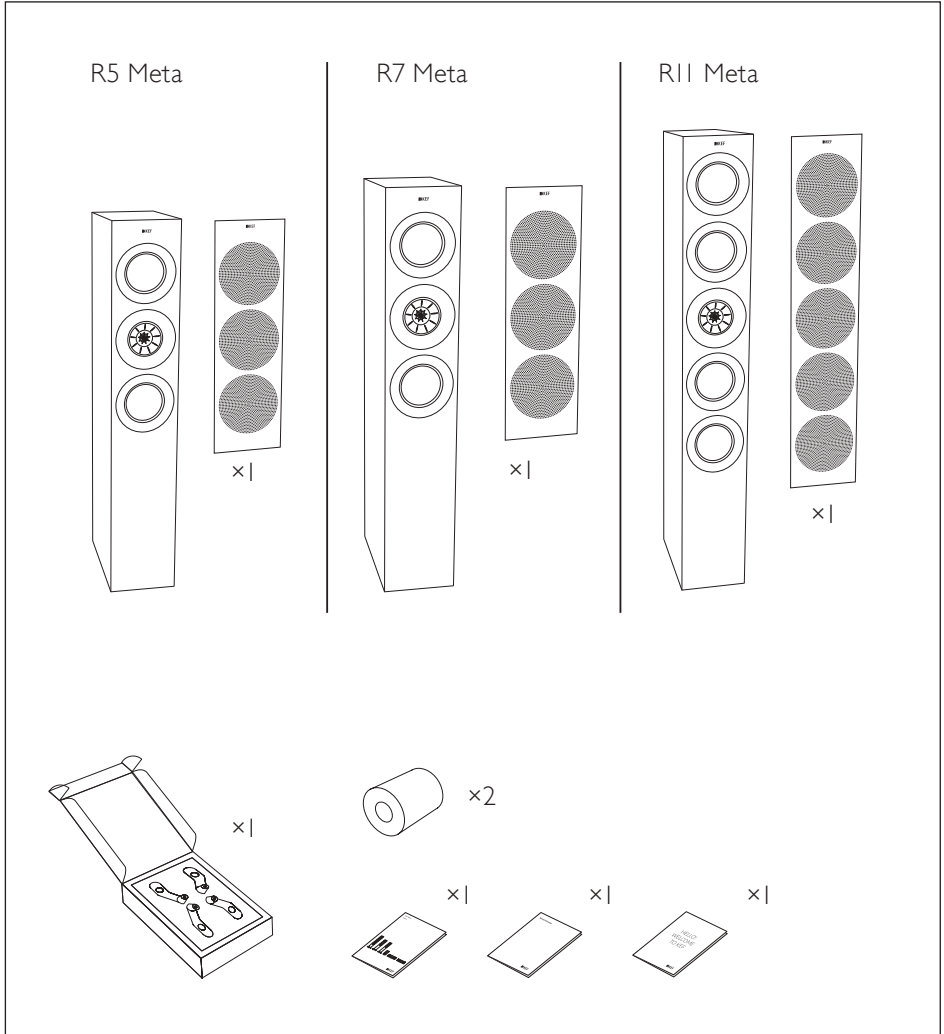

3.4 R8 Meta

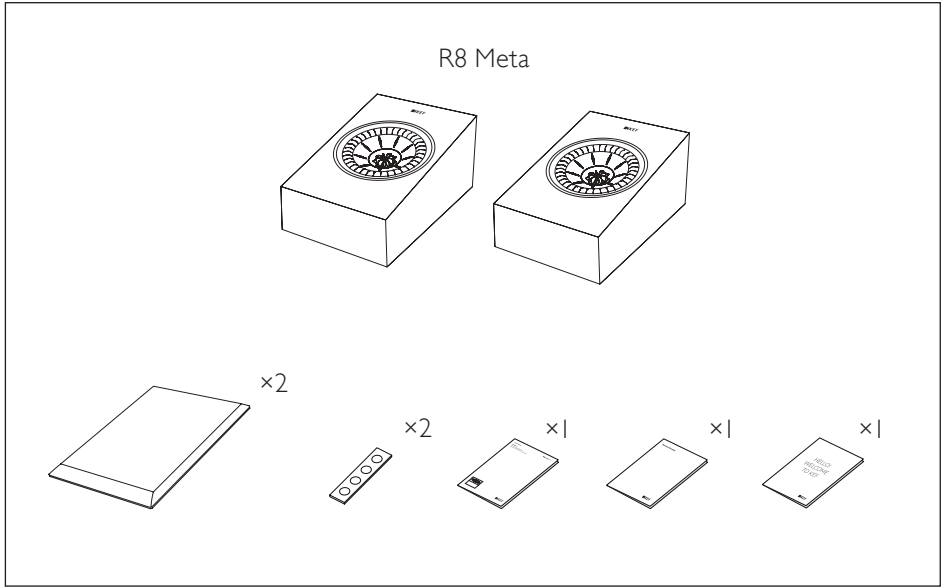

4. Loudspeaker Installation

4.1 Installing the Rubber Feet

Putting on the provided rubber feet helps to decouple the loudspeakers from their contacting surfaces. This helps to isolate any vibrations from transmitting between the loudspeakers and nearby furniture and objects, avoiding noise or resonances.

4.1.1 R3 Meta

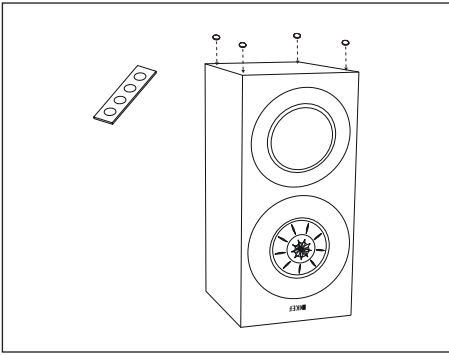

4.1.2 R8 Meta

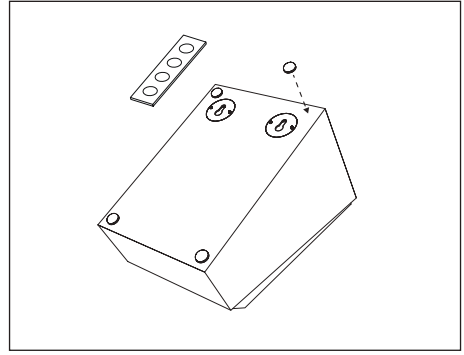

4.1.3 R2 Meta / R6 Meta

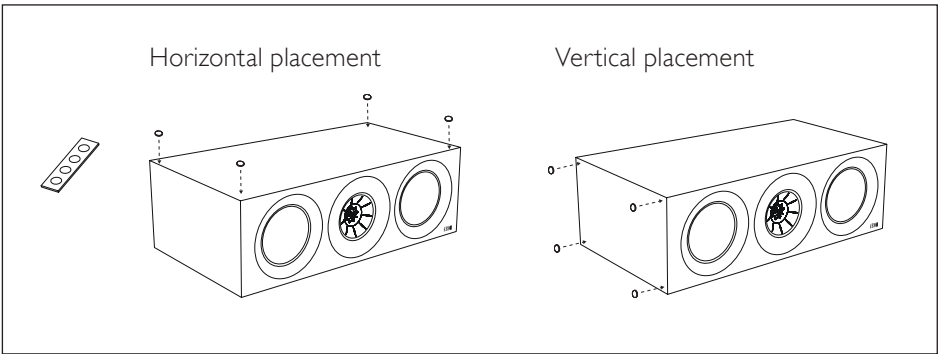

4.2 Installing the Plinths

4.2.1 R5 Meta / R7 Meta / R11 Meta

These loudspeakers are intended to be floor mounted only. It is important to ensure that the loudspeakers stand firmly on the floor using the plinths and spike feet supplied whenever possible for stability.

1. Align the plinths with their attachment holes on the underside of the loudspeaker. Secure the plinths using the screws and washers supplied.
2. Fit the spikes to the plinths using the spanner tool supplied.

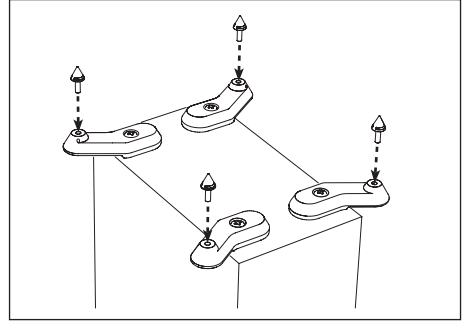
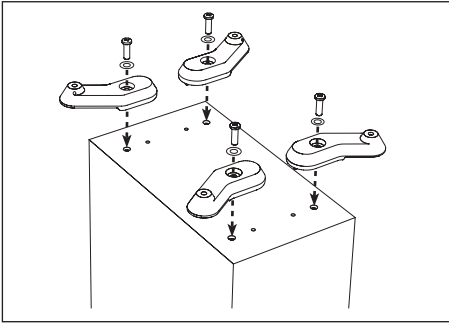

3. In case the loudspeaker wobbles when placed on the floor; use the spanner tool supplied to adjust the heights of the spikes until they all touch the floor and the loudspeaker firmly stands on the floor.
4. Finally, lock the spikes by tightening the grub screws with the hex key supplied.

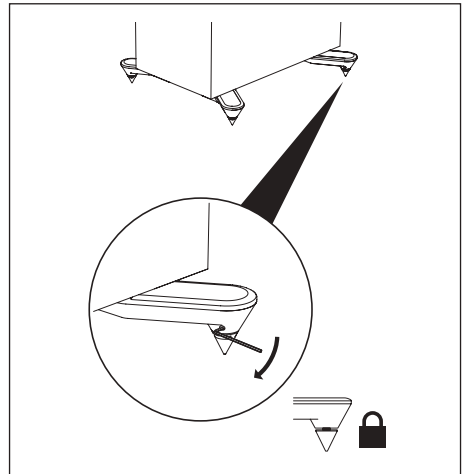
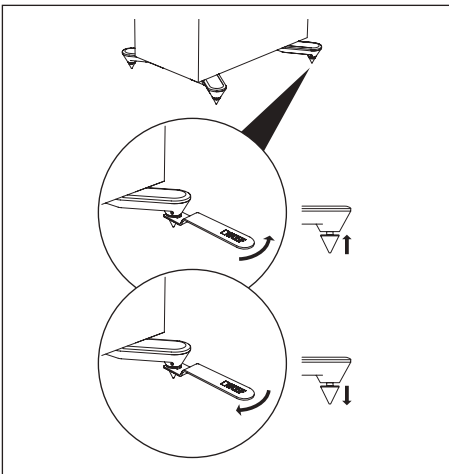

4.3 Installing Floorstanding Loudspeakers

Always use plinths at the bottom of the floorstanding loudspeakers and place the loudspeakers on solid, stable and level surfaces.

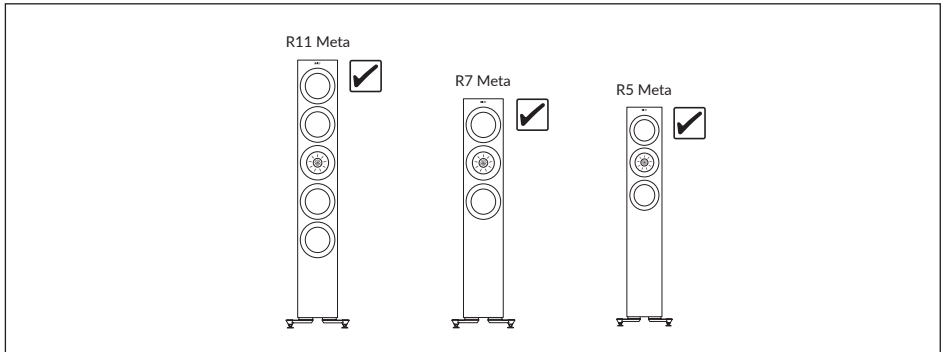

4.4 Installing Bookshelf Loudspeakers

Always place the bookshelf loudspeakers on shelves or stands. Do not place them directly on the floor.

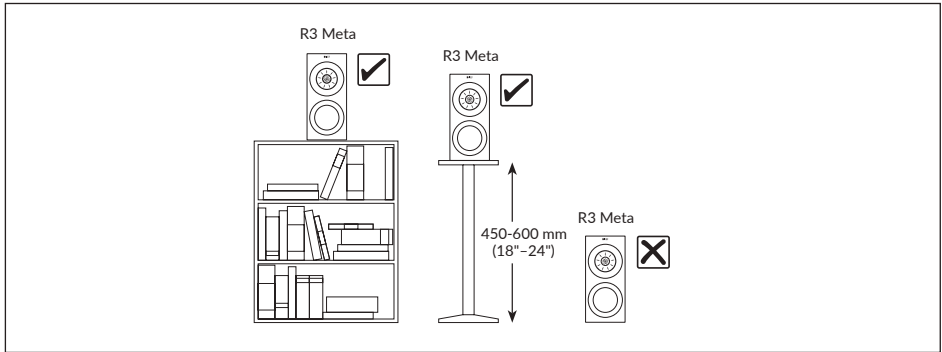

4.5 Installing Centre Loudspeakers

Always align the centre loudspeaker to the centre line of the screen, it can be above or below the TV, or directly behind a perforated projector screen (check with the projector screen manufacturer to make sure the screen is acoustically transparent). Do not place the centre loudspeaker directly on the floor.

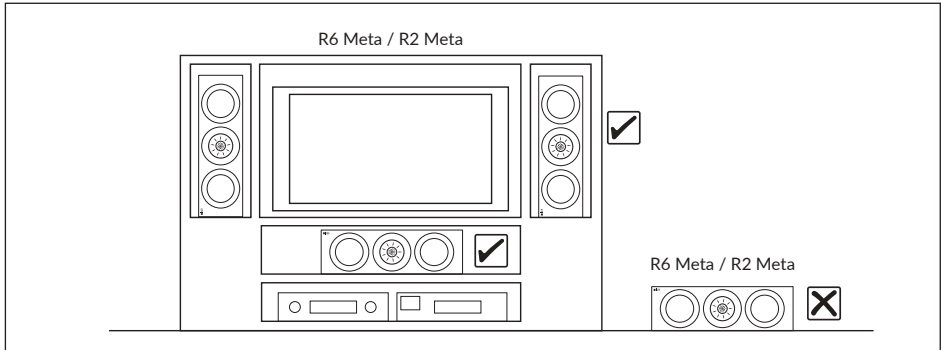

4.6 Installing R8 Meta on other speakers

NOTICE!

Risk of damage!

Improper handling of the loudspeakers may result in damage.

- Always use rubber feet at the bottom of the surround loudspeakers and place them above floorstanding or bookshelf loudspeakers. Do not place them directly on the floor.

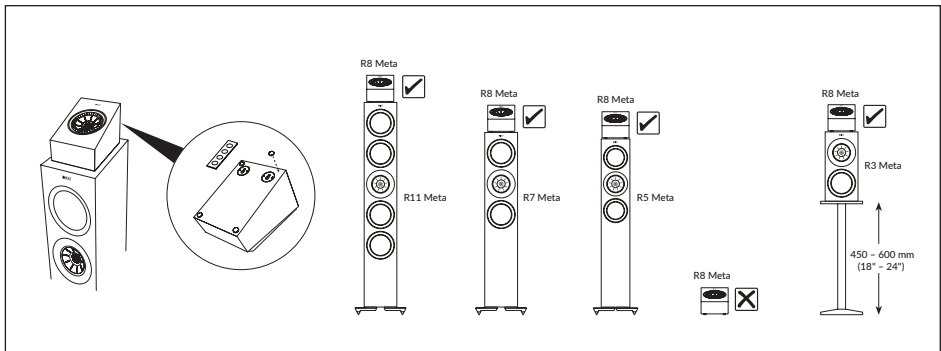

4.7 Installing R8 Meta on a Wall

⚠ WARNING!

Risk of injury and damage!

Improper installation may result in injury and damage.

- No attempt should be made to install the loudspeakers on the walls unless you are sure that you will not be cutting through electric cables, water or gas pipes, or supporting joists.

Apart from being a Dolby Atmos enabled speaker to be used on top of another speaker, the R8 Meta can also be used as an on-wall Dolby Atmos speaker and an on-wall surround speaker.

As an on-wall Dolby Atmos speaker, install the R8 Meta about the same width as your front/rear speaker, and as close to the wall/ceiling edge as possible.

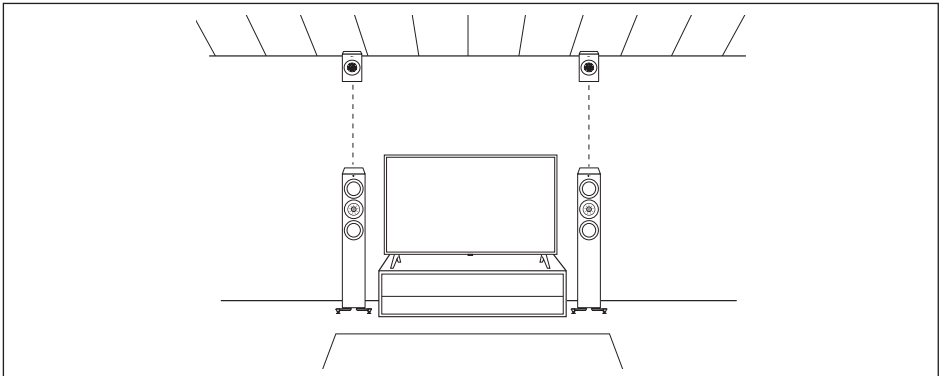

As an on-wall surround speaker, mount the R8 Meta at the desired location so that the Uni-Q driver points towards the head level of the listening area and adjust as you see fit (usually 600 mm or 2 feet above ear level).

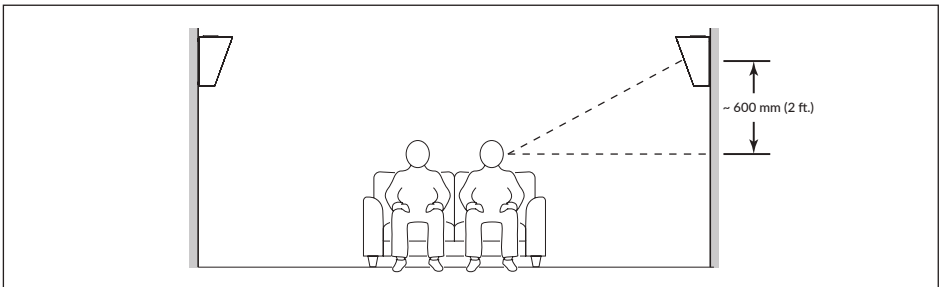

1. Determine the installation location and use the supplied template to mark the drilling points (see chapter "Dimensional Drawings").
2. Drill 2 holes on the walls with an electric drill.

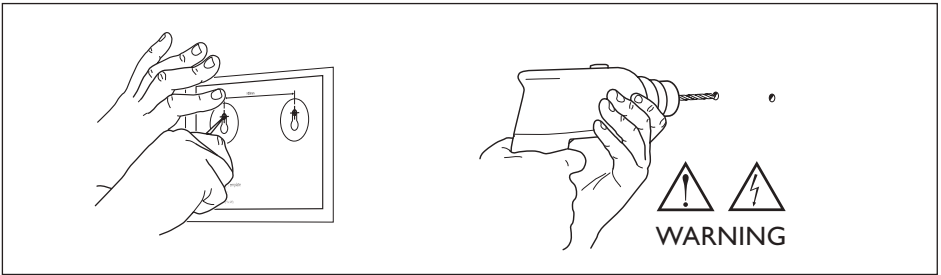

3. Insert a pair of hollow wall fixings (not supplied) into the drilled holes, then drive 2 screws (not supplied) into the fixings. Take note of the required protrusion and clearance.
4. Hang the loudspeaker on the protruding heads of the screws.

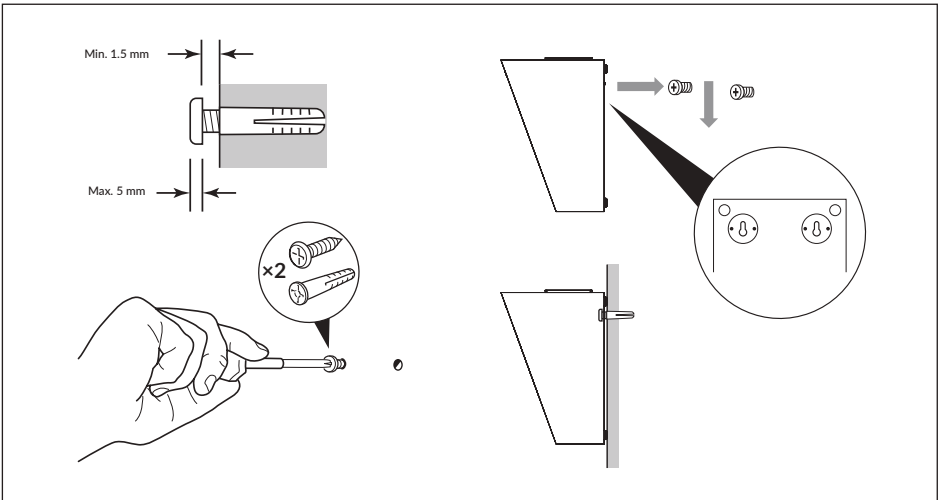

5. Loudspeaker Positioning

5.1 Listening Space and Uni-Q Driver Array

The KEF R Series loudspeaker systems are all equipped with Uni-Q driver arrays. The Uni-Q technology is designed to significantly improve loudspeaker placement flexibility and enhance the listening experience in various listening environments.

With the tweeter placed precisely at the acoustic centre of the bass/midrange cone, this unique design has several benefits that make it well-suited for different loudspeaker placements:

- Ensures a more coherent and time-aligned sound dispersion, reducing phase issues and improving off-axis response. You can enjoy a more consistent sound quality from various listening positions in the room.
- Creates a wider listening sweet spot where you can experience high-quality sound even when you are not directly in front of the loudspeaker on-axis.
- Enables versatile placement options without compromising sound quality. You have greater flexibility to adapt the loudspeaker placement to your room's layout and listening preferences.

5.2 Importance of Positioning Your Loudspeakers

Even with the benefits that the Uni-Q driver array bring, loudspeaker positioning in a room is still of utmost importance when it comes to achieving the best possible audio performance and listening experience.

Here are the benefits of getting the loudspeakers positioned properly:

- Creates an ideal listening area where the audio quality is at its best in your space.
- Creates a well-defined and immersive soundstage where sounds, voices or instruments appear to come from a specific location.
- Controls the reflections on the surfaces in a room (e.g. walls, floor and ceiling), leading to a well-defined imaging and correct tonal balance.
- Minimises room resonances (standing waves which could cause bass cancellations or emphasis) and enhances the perceived tonal balance of the system.

5.3 Setting up Your Loudspeakers

Follow these steps to position your loudspeakers for optimal sound quality:

1. Take note of the room's dimensions, shape and construction materials. Different room sizes and shapes will affect the way sound transmits and interacts with surfaces, impacting the loudspeaker positioning choices.

Large empty spaces with hard surfaces (e.g. windows and mirrors) tend to create more acoustic issues. If possible, add furniture, curtains, area rugs, and other soft furnishings to help diffuse and absorb sound.

2. Identify where you will be sitting most of the time when listening to music or watching movies.
 - If possible, avoid a primary listening position in close proximity to any of the walls.
 - If your room is rectangular, it is most ideal to setup up your TV and loudspeakers against one of the short walls and have the loudspeakers face the longer dimension of the room.

These guidelines are for reference only. Remember that your listening space and preferences are unique. Feel free to experiment to find out the setup that you enjoy the most.

5.3.1 Stereo System

- In a stereo system, place the two front loudspeakers at an equal distance from the mid point of the primary listening area, so that they form an quasi-equilateral triangle. This helps to ensure the best stereo imaging.
- Ideally the loudspeakers should be 1.5 m to 3 m apart. The distance should be wider or at least the same as the width of the listening area.
- Symmetry is very important for optimal stereo. Try to keep the loudspeakers and the listening area symmetrical with respect to the room layout. Ideally the side walls, to the left and the right of the loudspeakers, should be at the same distance and of the same construction.
- Ideally a wall (also known as the "front wall") should be directly behind the front loudspeakers. Both loudspeakers should be the same distance from this wall. The distance between the loudspeakers and the "front wall" is usually the most sensitive parameter for low frequency tuning. Experiment with different distances to find the best compromise between bass response and overall sound, ideally it should not be less than 225 mm (9") but in cases where this cannot be met, it is advised to tune with port bungs (see chapter [Port bungs](#)).
- It is advised to keep at least 0.5 m (20") distance between the speaker and the side wall.

- With Uni-Q technology, the KEF R series loudspeakers have a wider listening sweet spot and can work well without toeing-in. However, it is always a good idea to experiment to fine-tune the stereo image to your preferences by trying different toe-in angle.

5.3.1.1 Positioning Stereo System

i Take note of the recommended distances when positioning the loudspeakers.

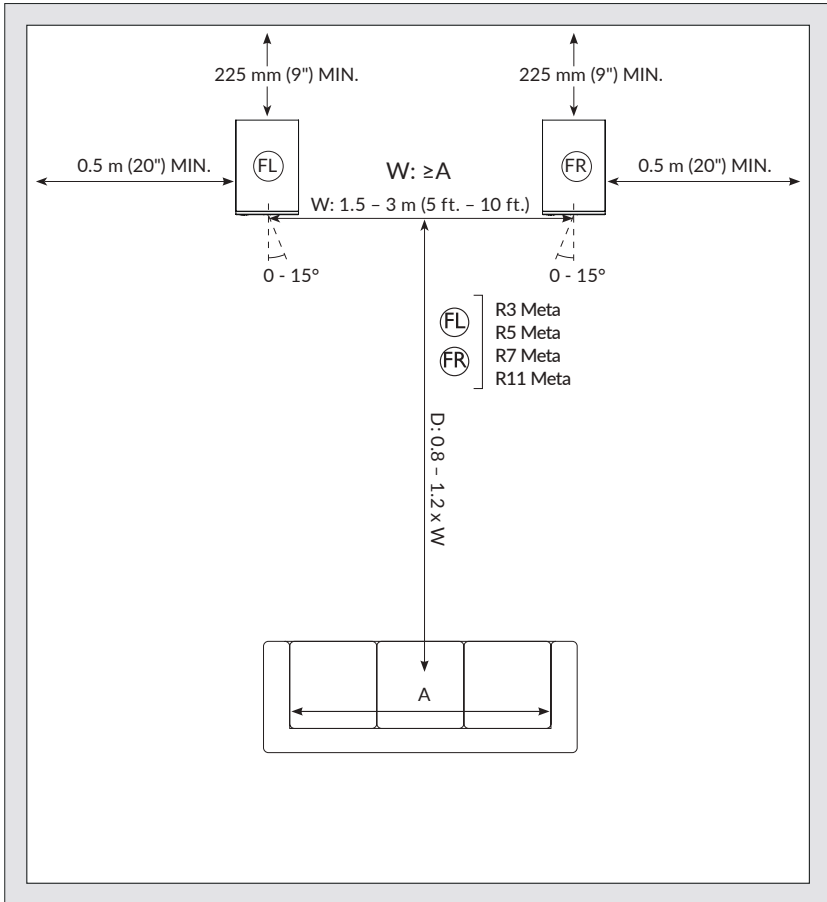

Channel abbreviations:

FL = Front left, FR = Front right

5.3.2 Home Theatre System

- If you have a home theater setup, always position the centre channel loudspeaker to line up with the centre line of the screen horizontally and as close to the screen as possible. It can be above or below the TV, or directly behind a perforated projector screen (check with the projector screen manufacturer to make sure the screen is acoustically transparent). It should be directed towards the primary listening area. Getting the centre channel loudspeaker setup right is the key to how your home theatre system will sound.
- For the front left and right main loudspeakers, the guidelines in 5.3.1 Stereo System still applies, but it is advised to place them close to the side edges of the screen to keep the sound image in scale with the visual image.
- If you have a subwoofer, its placement is more flexible, as bass frequencies are omnidirectional. Experiment with different positions to find the spot where the bass response is the most even and natural. Common locations are corners or along a wall. Nevertheless, avoid placing the subwoofer too close to adjacent walls.
- For the surround loudspeakers, position them on the sides or slightly behind the primary listening area, as shown in following diagrams.

5.3.2.1 Positioning a 5.2 or 7.2 System

i Take note of the recommended distances when positioning the loudspeakers.

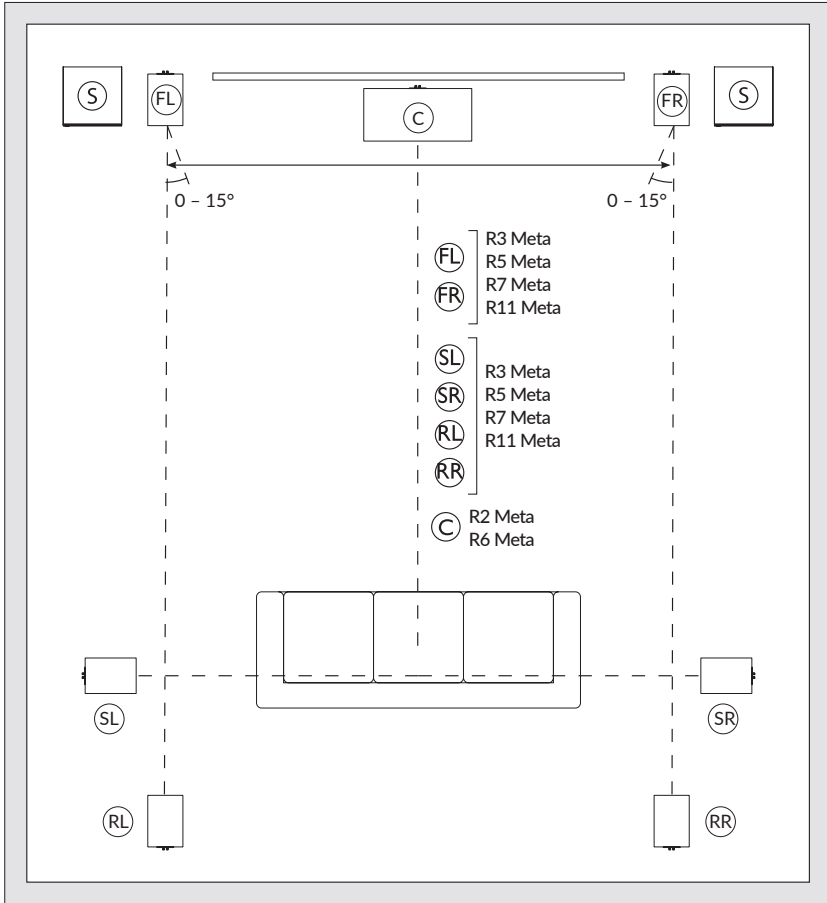

Channel abbreviations:

FL = Front left, FR = Front right, SL = Surround left, SR = Surround right, RL = Rear left, RR = Rear right, C = Centre, S = Optional KEF subwoofer

5.3.2.2 Positioning a 5.1.4 System

i Take note of the recommended distances when positioning the loudspeakers.

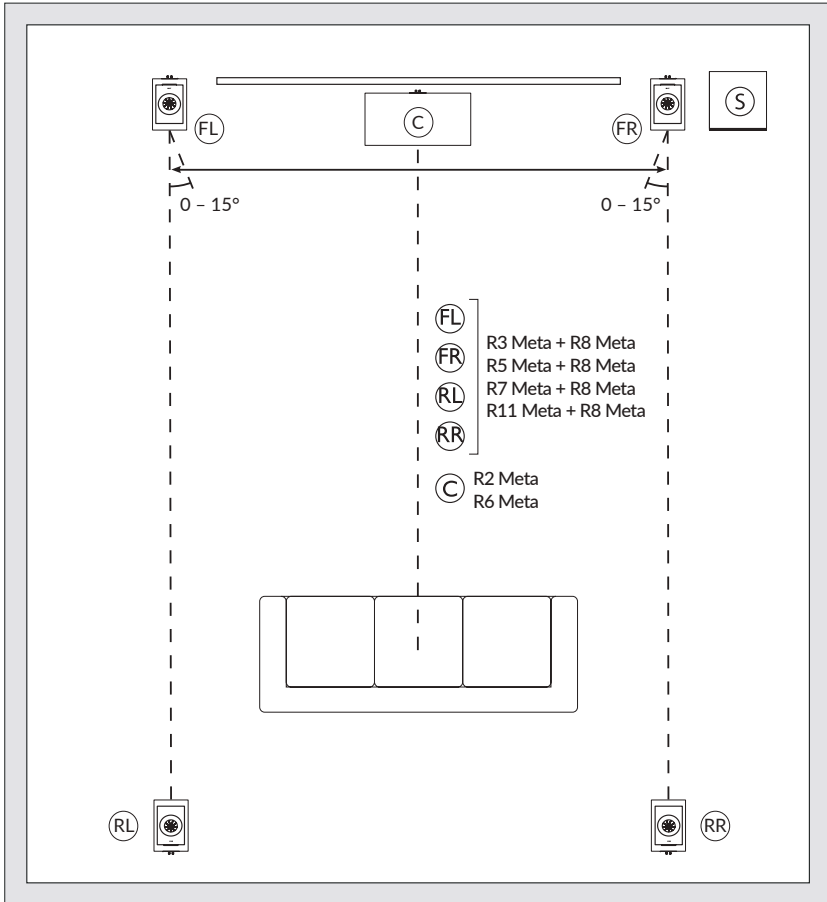

Channel abbreviations:

FL = Front left, FR = Front right, RL = Rear left, RR = Rear right, C = Centre, S = Optional KEF subwoofer

5.3.2.3 Positioning a 7.1.4 System

i Take note of the recommended distances when positioning the loudspeakers.

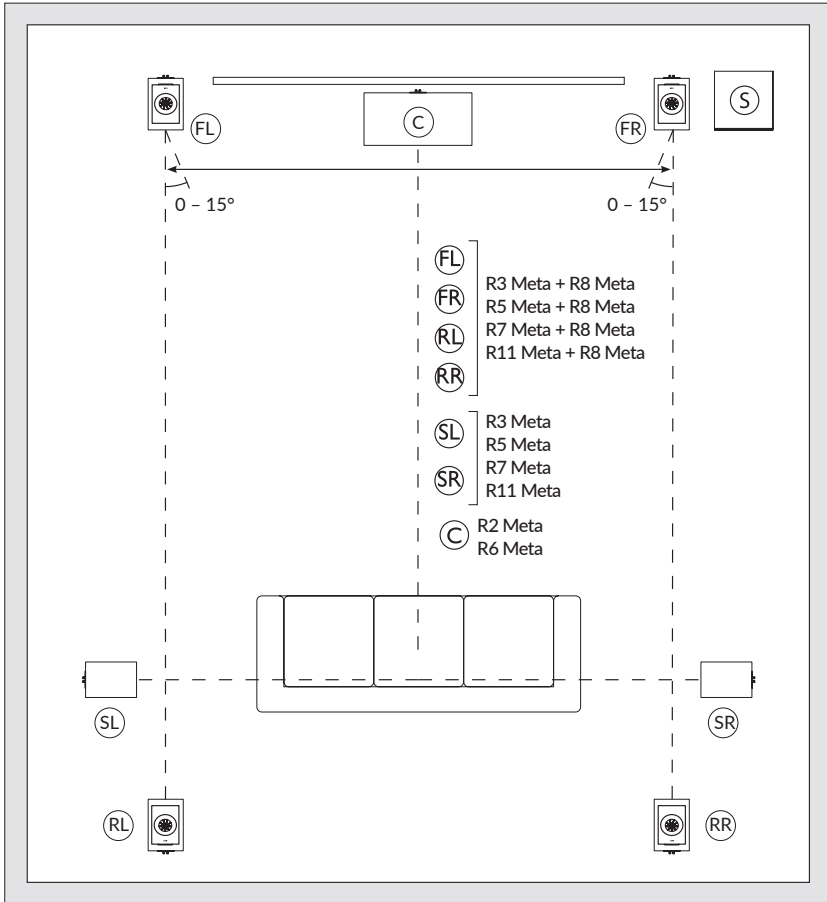

Channel abbreviations:

FL = Front left, FR = Front right, RL = Rear left, RR = Rear right, SL = Surround left, SR = Surround right, C = Centre, S = Optional KEF subwoofer

5.4 Positioning in Irregular Rooms

- Try to maintain a consistent acoustic environment surrounding each speaker. In the example below, try to move the rear left speaker closer to the left wall and the rear right speaker further away from the lower right corner. This can help compensate the imbalance in sound due to space difference around the speakers.
- If the speakers are placed at difference distances to the listening position, it is recommended to compensate for the distance difference in the AV processor settings for the best result. In below example, as the rear left speaker is placed further away from listening position than the rear right speaker, the rear left speaker signal delay should be reduced and amplitude should be increased to avoid sound from skewing towards one direction.
- Fine-tune the loudspeaker placements by listening to familiar music or movie scenes. Make small adjustments to the position and angle of the loudspeakers to optimise the sound.



Take note of the recommended distances when positioning the loudspeakers.

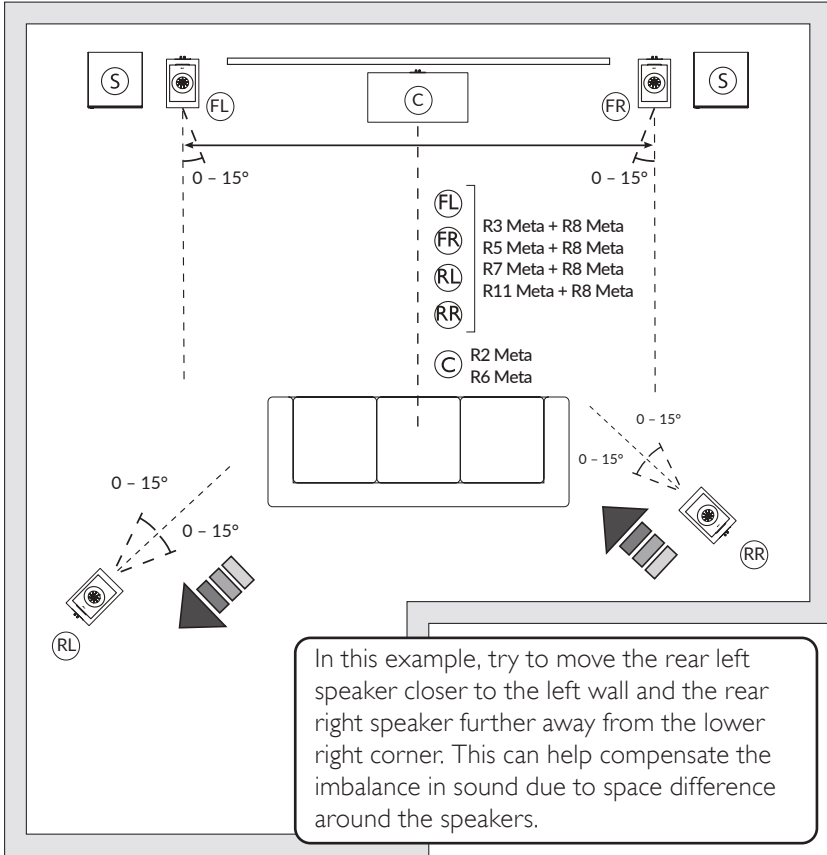

Channel abbreviations:

FL = Front left, FR = Front right, RL = Rear left, RR = Rear right, C = Centre, S = Optional KEF subwoofer

5.5 Managing Room Modes

Room modes are a phenomenon that occur in enclosed spaces caused by soundwaves reflecting off of the various surfaces in a room interfering with each other. These sound waves can constructively or destructively interfere with each other, resulting in room positions with strong peaks or dips in the frequency response. When positioning your loudspeakers, room modes can significantly impact the sound quality and perceived tonal balance in the listening area. Room modes are usually most noticeable in the low-frequency range (< 300 Hz), impacting the bass response of the loudspeakers and leading to an uneven and inaccurate representation of the audio.

To address room modes when positioning your loudspeakers, several techniques can be used:

- If using a subwoofer, experiment with different subwoofer positions to find the spot where the bass response is the most even.
- Use bass traps in corners or along wall-ceiling and wall-floor junctions to reduce room modes.
- Strategically place diffusion panels (often made of materials with irregular surfaces) to break up sound waves and avoid overly dead-sounding spaces.

6. Connections

NOTICE!

Risk of damage!

Improper handling of the loudspeakers may result in damage.

- Switch off all audio equipment before connecting the loudspeakers.



If you want to connect the loudspeakers with banana plugs, make sure that the plastic caps at the binding posts of the connectors are removed before doing so. You can remove the plastic caps by fully unscrewing the metal caps on the connectors.

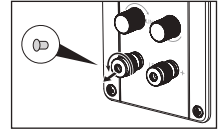

6.1 Single Wire or Bi-Wire Connections

You can connect the loudspeakers to your amplifier with single wire or bi-wire connections.

In a single wire connection, a standard loudspeaker cable with two conductors is used to connect the amplifier to the loudspeaker.

Bi-wire connections use two separate loudspeaker cables for each loudspeaker. These cables typically have a pair of connectors at the amplifier end and are divided into two separate pairs at the loudspeaker end. At the loudspeaker end, one pair of the cables connects to the loudspeaker's high-frequency (HF) terminals, and the other pair connects to the low-frequency (LF) terminals.

For the KEF R Series loudspeakers, you can use one of the connection methods:

- To enable single wire connections, rotate the Link connection knobs clockwise until the knob is fully tightened and the yellow rings at the base of the knobs cannot be seen.
- To enable bi-wire connections, rotate the Link connection knobs anticlockwise (or counterclockwise) until the yellow rings at the base of the knobs fully reveal.

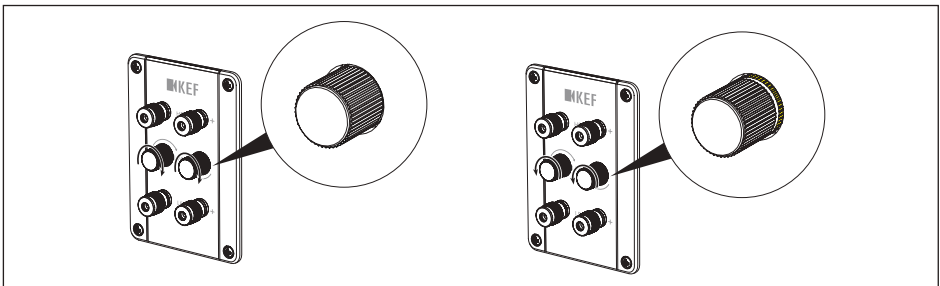

6.2 Bi-Amplification

NOTICE!

Risk of damage!

Improper handling of the loudspeakers may result in damage.

- Follow the bi-wire connection steps to make sure the Link connections are disengaged. Otherwise, it could cause damage to your equipment.

Bi-amplification (bi-amping) is possible for the KEF R Series loudspeakers. It is a loudspeaker setup method using two separate amplifiers or amplifier channels to power different drivers within a loudspeaker.

6.3 Making Connections

6.3.1 R3 Meta / R5 Meta / R7 Meta / R11 Meta

Single wire connections

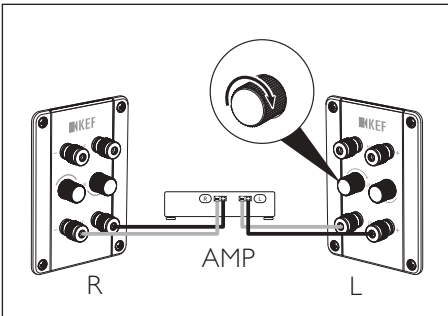

Bi-wire connections

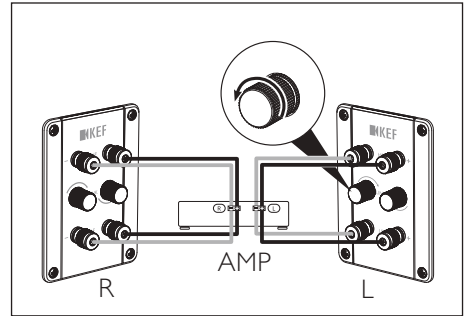

Bi-amplified connections

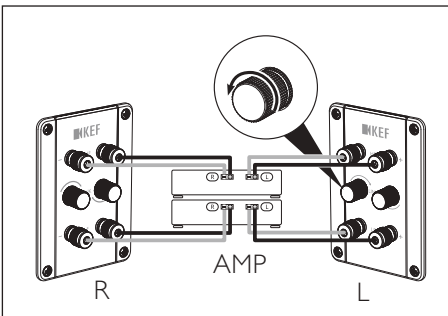

Abbreviations: R = Right, L = Left, AMP = Amplifier

6.3.2 R2 Meta / R6 Meta

Single wire connections

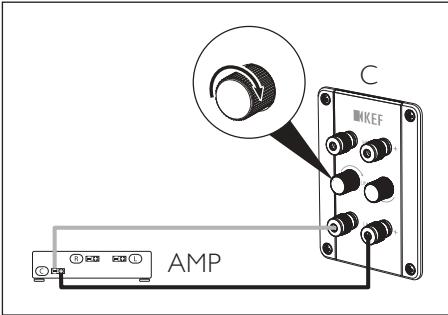

Bi-wire connections

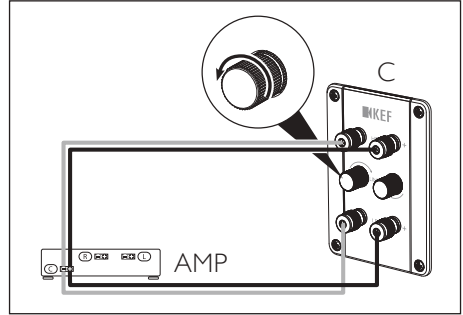

Bi-amplified connections

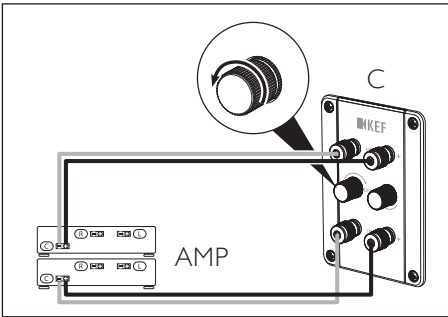

Abbreviations: C = Centre, AMP = Amplifier

6.3.3 R8 Meta

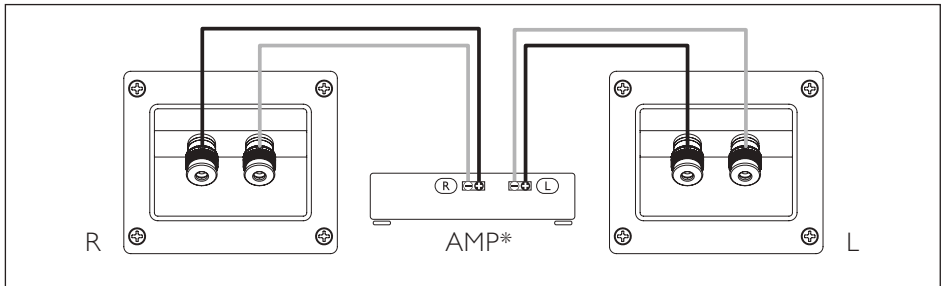

Abbreviations: R = Right, L = Left, AMP = Amplifier

*Dolby Atmos supported amplifiers

6.4 Cable Gauge and Length

The relationship between cable gauge* and length in a loudspeaker setup is an important consideration to ensure optimal audio performance and minimize signal loss. The rule of thumb is: the thicker the cable (smaller AWG) the better. The longer the distance between the amplifier and the loudspeaker, the thicker the cable is required for good performance.

Refer to the table below for recommendations on cable lengths in relation to the loudspeaker's nominal impedances and cable gauges. The R Series loudspeakers have a nominal impedance of 4 ohms.

U.S. cable standard	Cable cross-section (mm ²)	Nominal impedance of loudspeakers		
		4 ohms	6 ohms	8 ohms
18 AWG	0.823	4.9 m / 16 ft	7.3 m / 24 ft	9.8 m / 32 ft
16 AWG	1.31	7.3 m / 24 ft	11.0 m / 36 ft	14.6 m / 48 ft
14 AWG	2.08	12.2 m / 40 ft	18.3 m / 60 ft	24.4 m / 80 ft
12 AWG	3.31	18.3 m / 60 ft	27.4 m / 90 ft	36.6 m / 120 ft
10 AWG	5.26	30.5 m / 100 ft	45.7 m / 150 ft	61.0 m / 200 ft

*Cable gauge refers to the thickness or diameter of the wire used in the loudspeaker cables. It is typically measured in American Wire Gauge (AWG) or millimeters squared (mm²).

7. Fine Tuning

Remember that fine-tuning involves experimentation. Listen to your loudspeakers at different positions and volume levels to assess the impact of each adjustment. Be patient and give yourself time to make adjustments based on what sounds best to you.

7.1 Port Bungs

Use the supplied port bungs to customise the loudspeaker's bass characteristics to better suit your listening environment or preferences.

You may consider using port bungs if the loudspeakers are too close to a wall.

- In general, port bungs are not required if the distances to the walls are greater than the specifications in the diagram below.

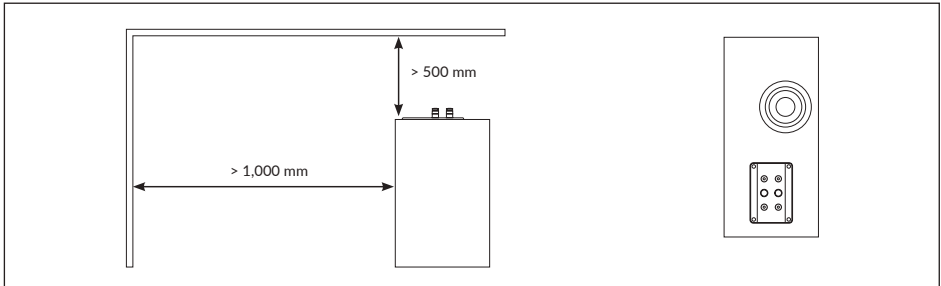

- The use of the outer rings of the port bungs is recommended if the distances to the walls are within the ranges in the diagram below.

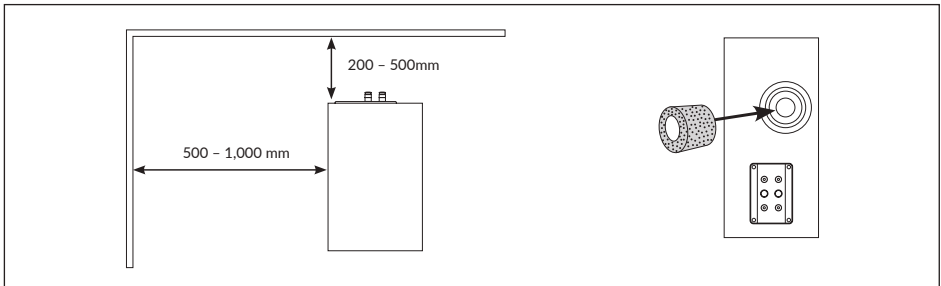

- The use of both outer rings and centre cores of the port bungs is recommended if the distances to the walls are smaller than the specifications in the diagram below.

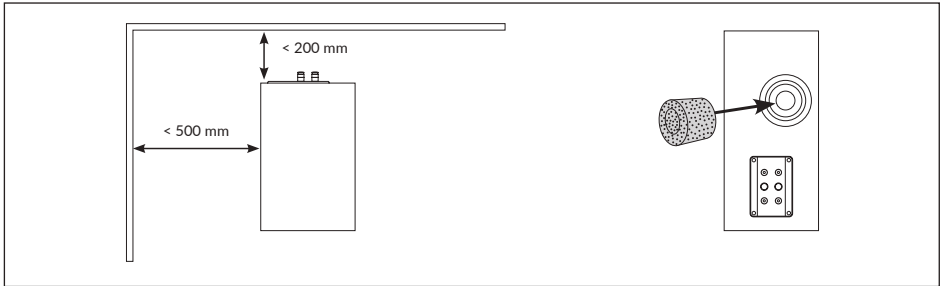

For models with more than one port, you may experiment with different combinations of port bungs.

Once the port bungs are inserted, play various types of music or audio content and listen to the changes in the bass response to find out which you prefer.

7.2 Using Customised Feet

Customised feet with the below specifications would fit the plinths of the R series loudspeakers.

- M8 Pitch 1.25 18 mm (R5 Meta, R7 Meta, R11 Meta)
- M8 Pitch 1.25 15 mm (R3 Meta)

8. Running In

Running in (also known as loudspeaker break-in or burn-in) is the process of conditioning new loudspeakers to reach their optimal performance level.

When loudspeakers are manufactured, their components are relatively stiff and rigid. Running in the loudspeakers involves playing audio through them for a certain period of time to allow these components to loosen up and settle into their normal operating state (e.g. greater flexibility in the loudspeaker suspensions).

Some tips for running in loudspeakers:

- Start playing music at moderate volumes and gradually increase the volume level over time.
- Play a variety of music genres and audio contents during the running-in process to ensure that all frequency ranges are adequately exercised.
- Be patient and allow enough time for running-in to take its course. The duration varies depending on the loudspeaker design and materials used. However, it generally ranges from a few hours to several days of continuous play.

9. Care and Maintenance

NOTICE!

Risk of damage!

Improper handling of the loudspeakers may result in damage.

- Make sure that no water or other liquids penetrate the housing of the loudspeakers.
- Never immerse the loudspeakers in water or other liquids.
- Do not use any aggressive cleaners, brushes with metal or nylon bristles, or sharp or metallic utensils such as knives, hard scrapers and the like. They could damage the surface.

9.1 Cleaning the Loudspeakers

1. Clean the surfaces of the loudspeakers with a clean lint-free cloth. If necessary, use an alcohol-free cleaner (e.g. screen cleaner, eyeglass lens cleaner) to remove stubborn stains.
2. To clean the Uni-Q drivers (loudspeaker cones), use an anti-static cleaner and a soft sponge. Be careful as the drivers may be damaged if too much force is used.

9.2 Use and Storage of Microfibre Grilles

- Do not twist, bend or drop the grilles.
- Do not expose the grilles to direct sunlight.
- When not in use, store the grilles flat or in their original packaging.

9.3 Cleaning the Microfibre Grilles

- To remove dirt, wipe the grille surfaces with a dry, soft brush in a single direction.
- To remove stains:
 1. Only use a damp, lint-free cloth or natural sponge to dab and wipe the stain. Avoid rubbing to prevent spreading or tracking the stain deeper.
Do not use any stain remover or cleaning agent.
If you use a sponge, rinse it in clean water and wring well between each wipe.
 2. Let the grille air dry, do not apply heat.

10. Disposal

10.1 Disposing of the Packaging

Sort the packaging before you dispose of it. Dispose of paperboard, cardboard and wrappings in accordance with your local guidelines.

10.2 Disposing of the Loudspeakers

Old appliances may not be disposed of in the household waste!

The loudspeakers are electronic products and may not be able to be disposed of as household waste. Please dispose of your loudspeakers in accordance with the regulations in force in your city or county. This ensures that old appliances are recycled in a professional manner and reduces negative consequences.

11. FAQ and Troubleshooting

11.1 General

1. How to locate the serial numbers of the loudspeakers?

- The serial number can be found on the packaging box near one of the barcode labels on the side of the packaging box. Alternatively, it can also be found on the rear panel (where the speaker terminals are located) of the loudspeaker.

2. What type of loudspeaker cable is recommended?

- Consider loudspeaker cables made from high-quality oxygen-free copper or high purity copper conductors. They are designed to minimise oxidation and ensure better conductivity.
- Also consider loudspeaker cables with high quality insulation. They can reduce signal interference and ensure accurate signal transmission.

3. What is the recommended diameter of the loudspeaker cables?

- In general, the longer the run is from your amplifier to the loudspeakers, the lower the cable gauge is. See chapter "[Cable Gauge and Length](#)".

11.2 Floorstanding Loudspeakers

1. Can I use the loudspeakers without the plinths (traverse legs)?

- Using plinths is highly recommended. The plinths provide a more stable foundation which helps prevent the loudspeakers from tipping over.

2. What is the thread size of the spikes and the screws for the plinths?

- M8 (1.25 mm pitch)

3. Can I use other spikes instead of those that come with the loudspeakers?

- You can use third party spikes with the same specifications.

4. How far apart are the screw holes at the bottom of the plinths?

- Refer to the [Dimensional Drawings](#).

11.3 Loudspeakers on Bookshelves or Stands

1. What is the size of the screws for mounting the R3 Meta on the S3 stand?

- M8 (1.25 mm pitch)

2. How deep are the screw holes at the bottom of the loudspeakers?

- 18 mm

3. How far apart are the screw holes at the bottom of the loudspeakers?

- Refer to the [Dimensional Drawings](#).

4. What should be the height of the stand for R3 Meta so that the Uni-Q driver aligns with the other floorstanding speakers?

- Use a stand of 497 mm (19.5").

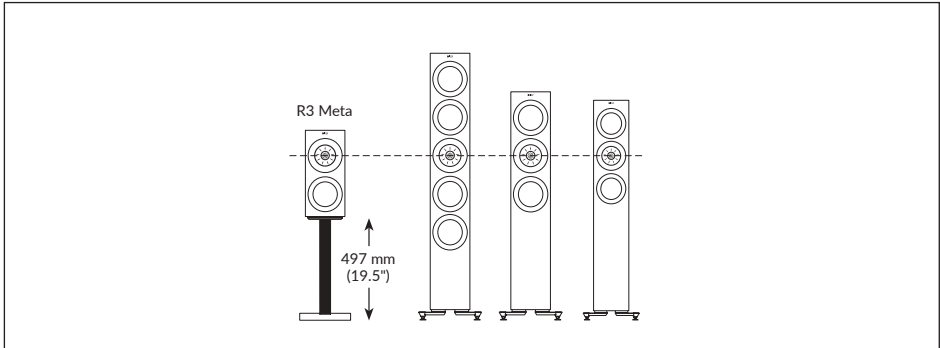

11.4 LCR (Left/Centre/Right Channel)

1. Are decoupling feet recommended?

- Install the supplied rubber feet to reduce vibrations and isolate the loudspeakers from the room and other objects.

2. Do I need to place the centre loudspeaker in an upward position?

- With the wide dispersion of the Uni-Q driver array, tilting of the centre loudspeaker to align with the ear level is in general not necessary. However, it is always a good practice to experiment with the placement and position of the loudspeaker to get the best possible audio performance.

11.5 Dolby Atmos Loudspeakers

1. What is the angle of the top/front baffle?

- The angle of the top/front baffle is 110 degrees.

11.6 Care and Maintenance

1. How should I clean the loudspeakers?

1. Clean the surfaces of the loudspeakers with a clean lint-free cloth. If necessary, use an alcohol-free cleaner (e.g. screen cleaner, eyeglass lens cleaner) to remove stubborn stains.

2. To clean the Uni-Q drivers (loudspeaker cones), use an anti-static cleaner and a soft sponge. Be careful as the drivers may be damaged if too much force is used.

2. What type of cleaning cloth is recommended for cleaning?

- Microfibre cloths are recommended.

3. How to remove scratches on the painted surfaces?

- If the scratches are superficial (only affecting the coat layer), a commercially available scratch removal product may help.
- Car wax may also help to fill in minor scratches and improve the overall appearance of the painted surface.
- If the scratches are deep and extensive, consider seeking professional help.

4. What kind of paint is applied on the loudspeakers?

- Polyester paint or acrylic paint is used.

5. How to remove wax on the loudspeakers?

- Allow the wax to cool and then use a plastic or wooden spatula to gently scrape off any excess wax from the surface.
- If there is still some residual wax, use a hair dryer on low heat to soften it and then wipe it with a paper towel or cloth.

6. What type of solvent is recommended to remove oil/fat from the painted surfaces?

- Always use a gentle solvent that will not damage the paint or cause discoloration. Some recommendations are mild dish soap solution, rubbing alcohol and any commercial degreaser.

12. Appendix

12.1 Specifications

R3 Meta

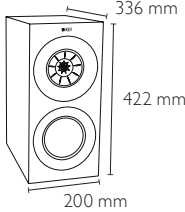
Model	R3 Meta
Design	Three-way bass reflex
Drive units	Uni-Q Driver Array: HF: 25 mm (1 in.) vented aluminium dome with MAT MF: 125 mm (5 in.) aluminium cone Bass Unit: LF: 165 mm (6.5 in.) hybrid aluminium cone
Crossover frequency	420 Hz, 2.3 kHz
Frequency range (-6 dB)	38 Hz – 50 kHz
Typical in-room bass response (-6 dB)	30 Hz
Frequency response (± 3 dB)	58 Hz – 28 kHz
Harmonic distortion (90 dB, 1 m)	< 1 % 73 Hz and above < 0.5 % 90 Hz – 20 kHz
Maximum output	110 dB
Amplifier power (recommended)	15 – 180 W
Nominal impedance	4 Ω (min. 3.2 Ω)
Sensitivity (2.83 V / 1 m)	87 dB
Weight*	12.4 kg (27.3 lbs)
Dimensions (H x W x D) with terminals*	422 x 200 x 336 mm (16.6 x 7.9 x 13.2 in.)
	
Finishes	Black Gloss / White Gloss / Walnut / Indigo Gloss Special Edition

*Measurement per unit

R5 Meta

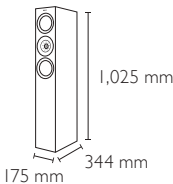
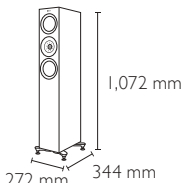
Model	R5 Meta	
Design	Three-way bass reflex	
Drive units	Uni-Q Driver Array: HF: 25 mm (1 in.) vented aluminium dome with MAT MF: 125 mm (5 in.) aluminium cone Bass Unit: LF: 2 × 130 mm (5.25 in.) hybrid aluminium cone	
Crossover frequency	400 Hz, 2.7 kHz	
Frequency range (-6 dB)	38 Hz – 50 kHz	
Typical in-room bass response (-6 dB)	29 Hz	
Frequency response (±3 dB)	52 Hz – 28 kHz	
Harmonic distortion (90 dB, 1 m)	< 1 % 75 Hz and above < 0.5 % 110 Hz – 20 kHz	
Maximum output	110 dB	
Amplifier power (recommended)	15 – 200 W	
Nominal impedance	4 Ω (min. 3.2 Ω)	
Sensitivity (2.83 V / 1 m)	87 dB	
Weight*	24.5 kg (54.0 lbs)	
Dimensions (H × W × D) with terminals*	1,025 × 175 × 344 mm (40.4 × 6.9 × 13.5 in.)	
Dimensions (H × W × D) with terminals and plinths*	1,072 × 272 × 344 mm (42.2 × 10.7 × 13.5 in.)	
Finishes	Black Gloss / White Gloss / Walnut	

*Measurement per unit

R7 Meta

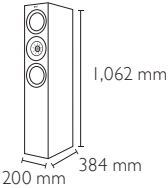
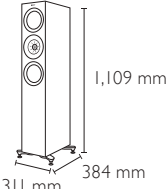
Model	R7 Meta	
Design	Three-way bass reflex	
Drive units	Uni-Q Driver Array: HF: 25 mm (1 in.) vented aluminium dome with MAT MF: 125 mm (5 in.) aluminium cone Bass Unit: LF: 2 × 165 mm (6.5 in.) hybrid aluminium cone	
Crossover frequency	400 Hz, 2.4 kHz	
Frequency range (-6 dB)	33 Hz – 50 kHz	
Typical in-room bass response (-6 dB)	27 Hz	
Frequency response (±3 dB)	48 Hz – 28 kHz	
Harmonic distortion (90 dB, 1 m)	< 1 % 76 Hz and above < 0.5 % 110 Hz – 20 kHz	
Maximum output	111 dB	
Amplifier power (recommended)	15 – 250 W	
Nominal impedance	4 Ω (min. 3.2 Ω)	
Sensitivity (2.83 V / 1 m)	88 dB	
Weight*	29.3 kg (64.6 lbs)	
Dimensions (H x W x D) with terminals*	1,062 × 200 × 384 mm (41.8 × 7.9 × 15.1 in.)	
Dimensions (H x W x D) with terminals and plinths*	1,109 × 311 × 384 mm (43.7 × 12.2 × 15.1 in.)	
Finishes	Black Gloss / White Gloss / Walnut / Titanium Gloss Special Edition	

*Measurement per unit

R11 Meta

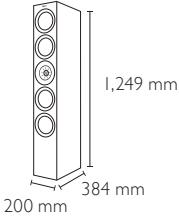
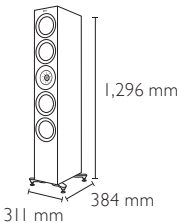
Model	R11 Meta	
Design	Three-way bass reflex	
Drive units	Uni-Q Driver Array: HF: 25 mm (1 in.) vented aluminium dome with MAT MF: 125 mm (5 in.) aluminium cone Bass Unit: LF: 4 × 165 mm (6.5 in.) hybrid aluminium cone	
Crossover frequency	330 Hz, 2.5 kHz	
Frequency range (-6 dB)	30 Hz – 50 kHz	
Typical in-room bass response (-6 dB)	26 Hz	
Frequency response (±3 dB)	46 Hz – 28 kHz	
Harmonic distortion (90 dB, 1 m)	< 1 % 33 Hz and above < 0.5 % 80 Hz – 20 kHz	
Maximum output	113 dB	
Amplifier power (recommended)	15 – 300 W	
Nominal impedance	4 Ω (min. 3.2 Ω)	
Sensitivity (2.83 V / 1 m)	90 dB	
Weight*	36.5 kg (80.5 lbs)	
Dimensions (H × W × D) with terminals*	1,249 × 200 × 384 mm (49.2 × 7.9 × 15.1 in.)	
Dimensions (H × W × D) with terminals and plinths*	1,296 × 311 × 384 mm (51.0 × 12.2 × 15.1 in.)	
Finishes	Black Gloss / White Gloss / Walnut	

*Measurement per unit

R2 Meta

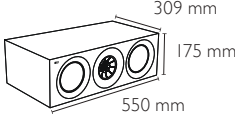
Model	R2 Meta
Design	Three-way closed box
Drive units	Uni-Q Driver Array: HF: 25 mm (1 in.) vented aluminium dome with MAT MF: 125 mm (5 in.) aluminium cone Bass Unit: LF: 2 × 130 mm (5.25 in.) hybrid aluminium cone
Crossover frequency	560 Hz, 2.5 kHz
Frequency range (-6 dB)	58 Hz – 50 kHz
Typical in-room bass response (-6 dB)	43 Hz
Frequency response (±3 dB)	67 Hz – 28 kHz
Harmonic distortion (90 dB, 1 m)	< 1 % 84 Hz and above < 0.5 % 95 Hz – 20 kHz
Maximum output	110 dB
Amplifier power (recommended)	15 – 200 W
Nominal impedance	4 Ω (min. 3.2 Ω)
Sensitivity (2.83 V / 1 m)	87 dB
Weight*	15.4 kg (34.0 lbs)
Dimensions (H x W x D) with terminals*	175 × 550 × 309 mm (6.9 × 21.7 × 12.2 in.)
	
Finishes	Black Gloss / White Gloss / Walnut

*Measurement per unit

R6 Meta

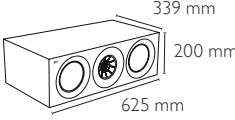
Model	R6 Meta
Design	Three-way closed box
Drive units	Uni-Q Driver Array: HF: 25 mm (1 in.) vented aluminium dome with MAT MF: 125 mm (5 in.) aluminium cone Bass Unit: LF: 2 × 165 mm (6.5 in.) hybrid aluminium cone
Crossover frequency	550 Hz, 2.4 kHz
Frequency range (-6 dB)	55 Hz – 50 kHz
Typical in-room bass response (-6 dB)	40 Hz
Frequency response (±3 dB)	65 Hz – 28 kHz
Harmonic distortion (90 dB, 1 m)	< 1 % 65 Hz and above < 0.5 % 93 Hz – 20 kHz
Maximum output	111 dB
Amplifier power (recommended)	15 – 250 W
Nominal impedance	4 Ω (min. 3.2 Ω)
Sensitivity (2.83 V / 1 m)	88 dB
Weight*	17.8 kg (39.2 lbs)
Dimensions (H x W x D) with terminals*	200 × 625 × 339 mm (7.9 × 24.6 × 13.3 in.)
	
Finishes	Black Gloss / White Gloss / Walnut

*Measurement per unit

R8 Meta

Model	R8 Meta
Design	Two-way closed box
Drive units	Uni-Q Driver Array: HF: 25 mm (1 in.) vented aluminium dome with MAT MF / LF: 130 mm (5.25 in.) aluminium cone
Crossover frequency	2.6 kHz
Frequency range (-6 dB)	88 Hz – 19.5 kHz
Typical in-room bass response (-6 dB)	–
Frequency response (± 3 dB)	97 Hz – 17.5 kHz
Harmonic distortion (90 dB, 1 m)	< 1 % 220 Hz and above < 0.5 % 320 Hz – 20 kHz
Maximum output	106 dB
Amplifier power (recommended)	25 – 150 W
Nominal impedance	4 Ω (min. 3.2 Ω)
Sensitivity (2.83 V / 1 m)	85 dB
Baffle angle	110°
Weight*	4.5 kg (9.9 lbs)
Dimensions (H x W x D) with terminals*	174 x 175 x 259 mm (6.9 x 6.9 x 10.2 in.)
	
Finishes	Black Gloss / White Gloss / Walnut

*Measurement per unit

Metamaterial Absorption Technology is a joint development with Acoustic Metamaterials Group.

Dolby, Dolby Atmos, and the double-D symbol are registered trademarks of Dolby Laboratories Licensing Corporation.

KEF reserves the right, in line with continuing research and development, to amend or change specifications. E&OE.

12.2 Dimensional Drawings

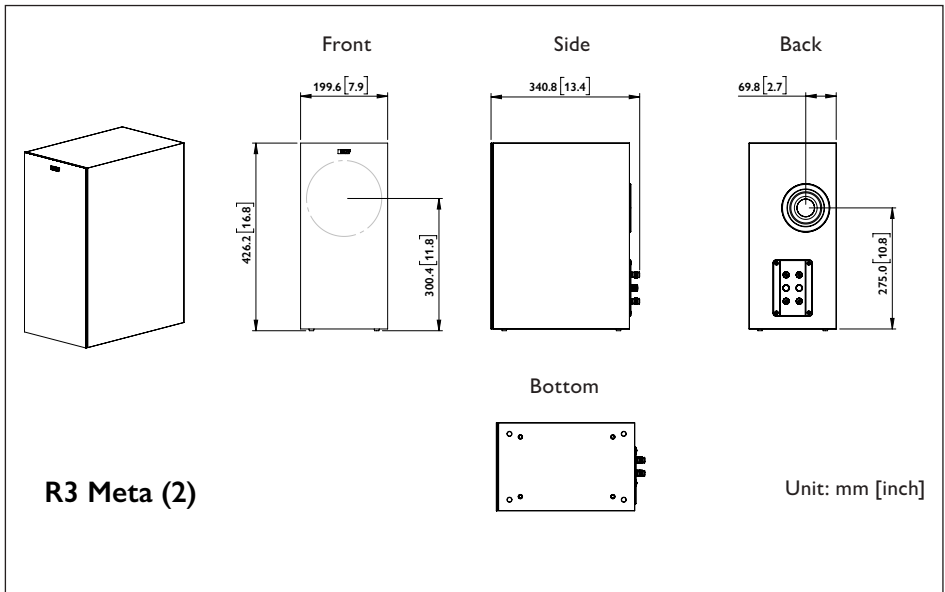
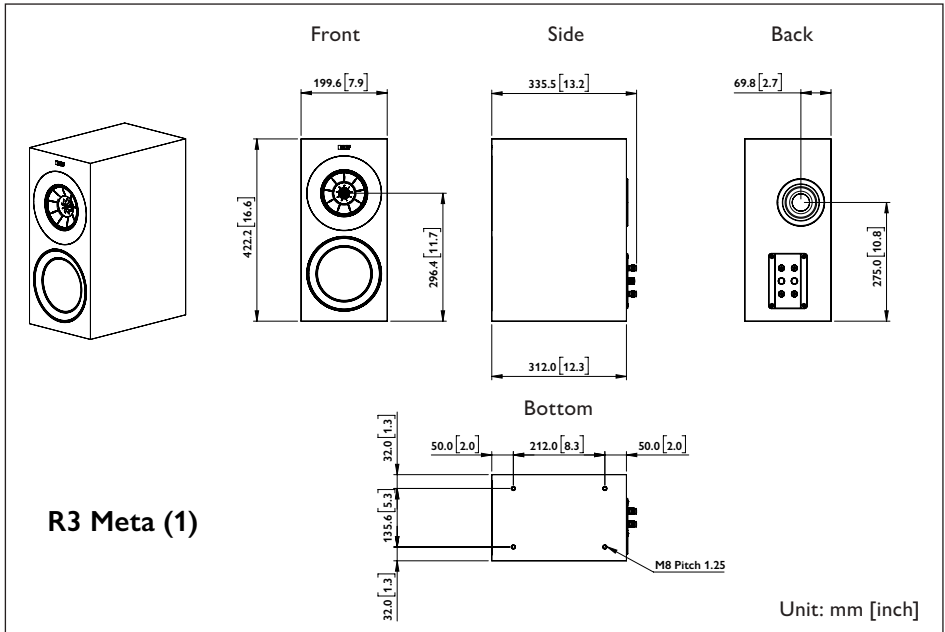

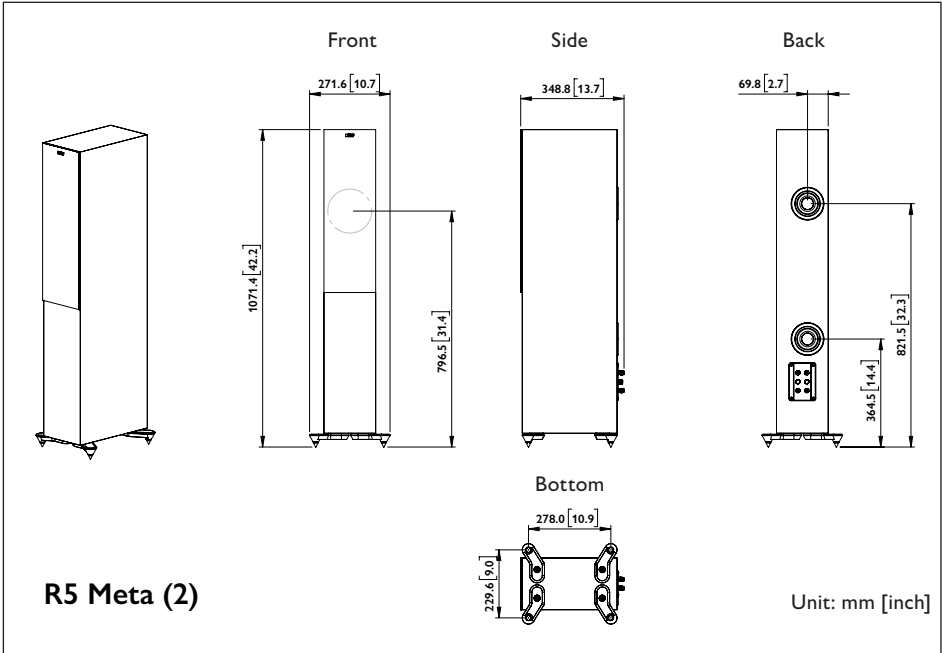
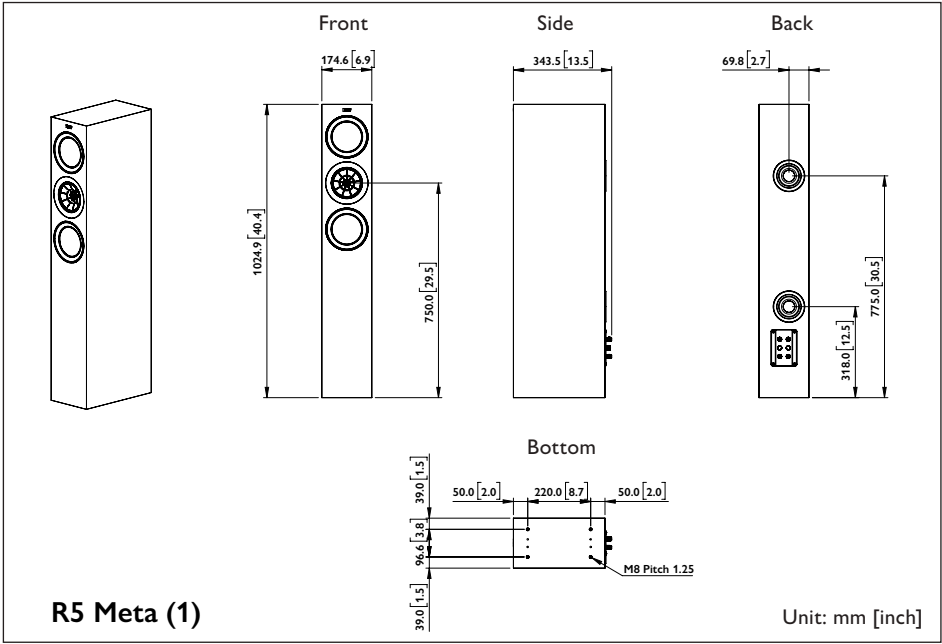

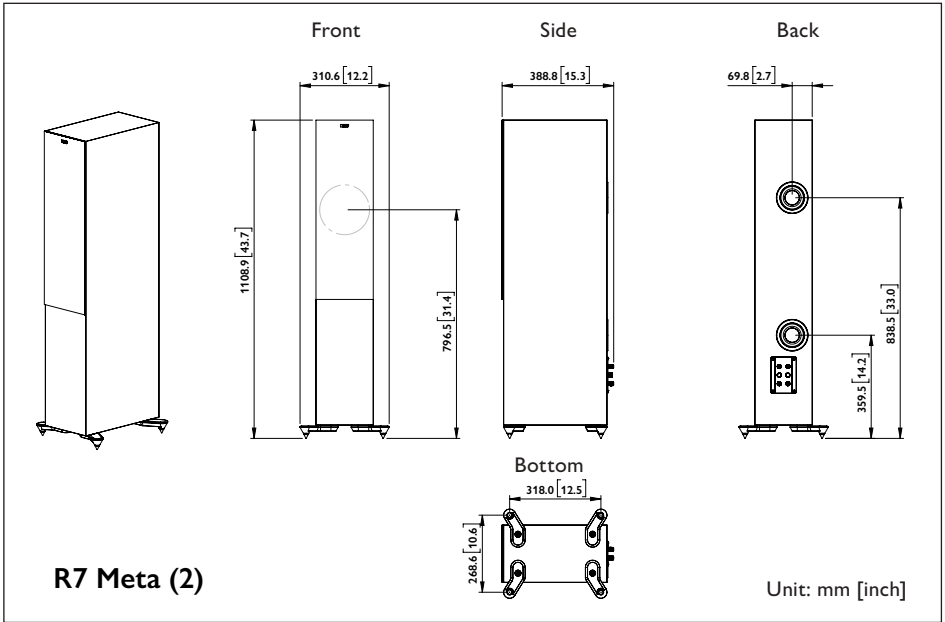
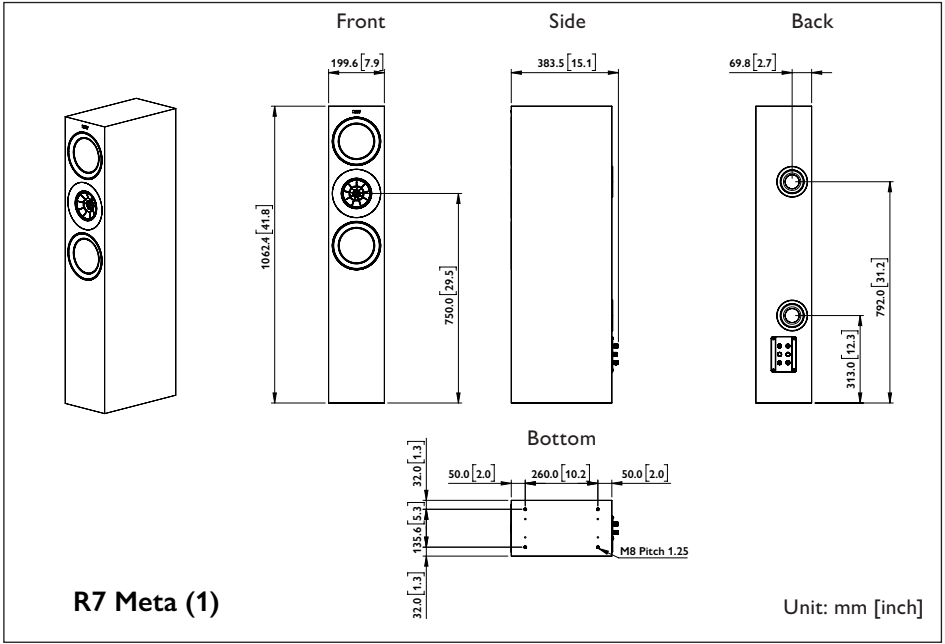

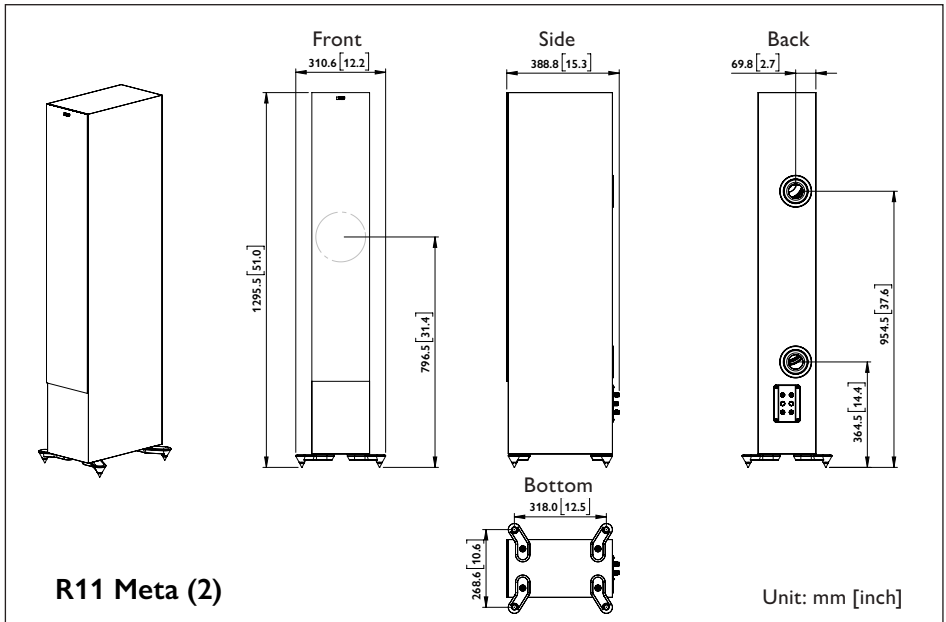
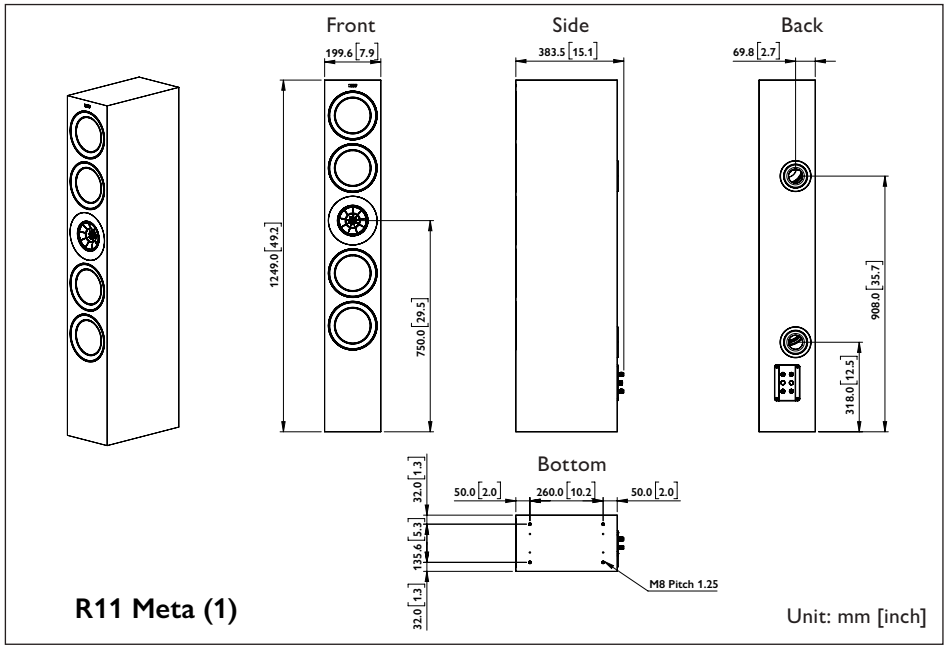

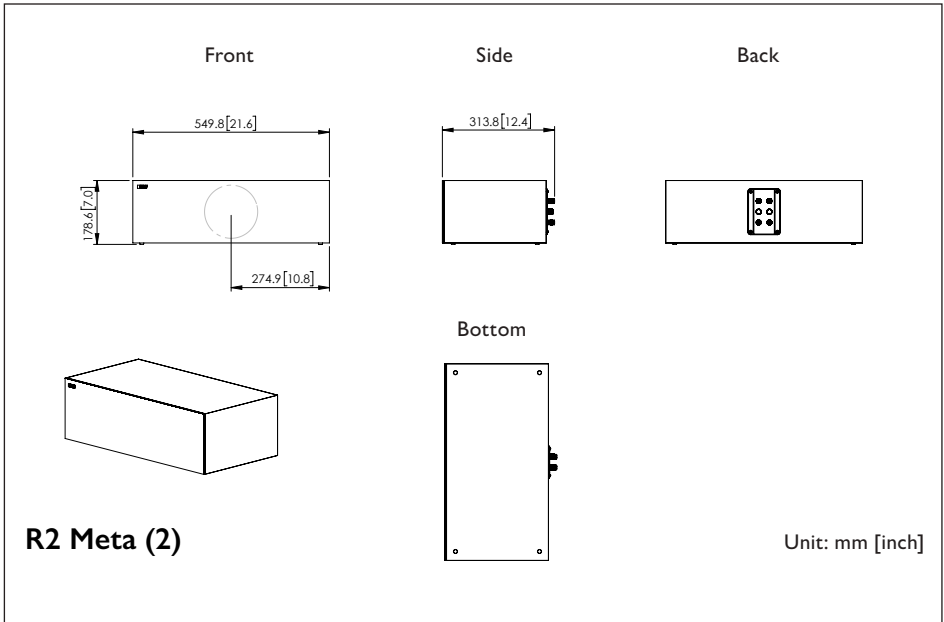
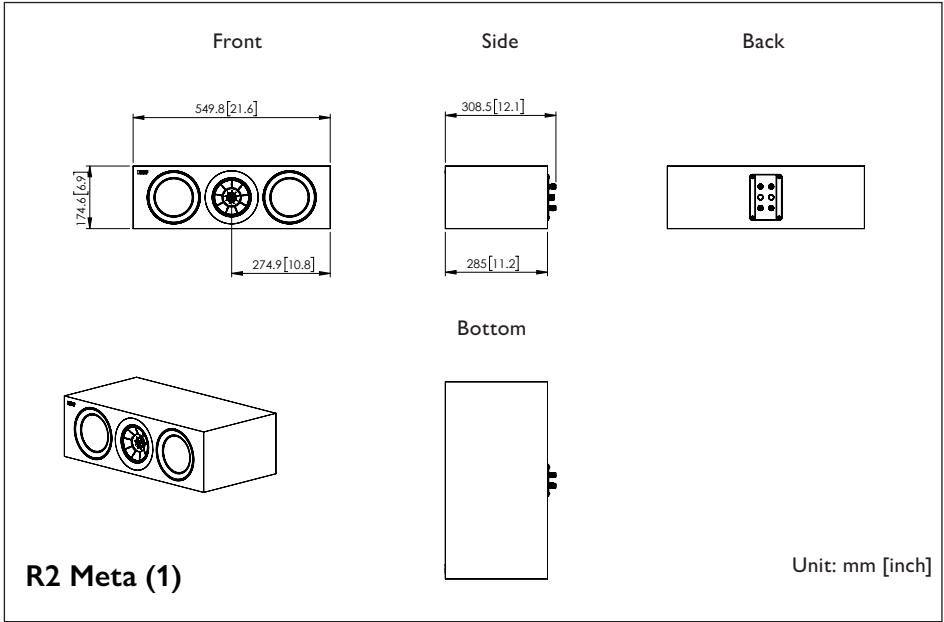

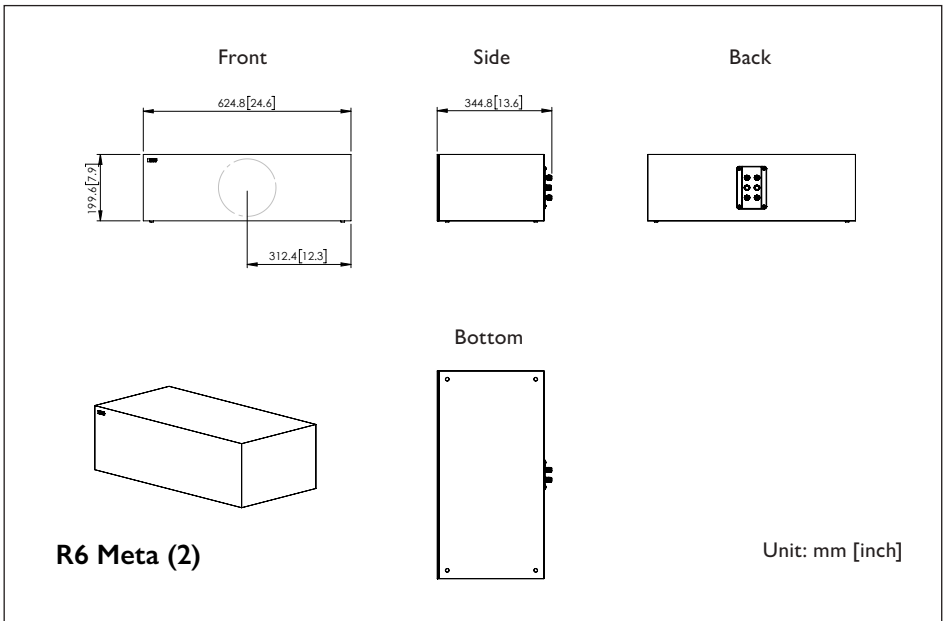
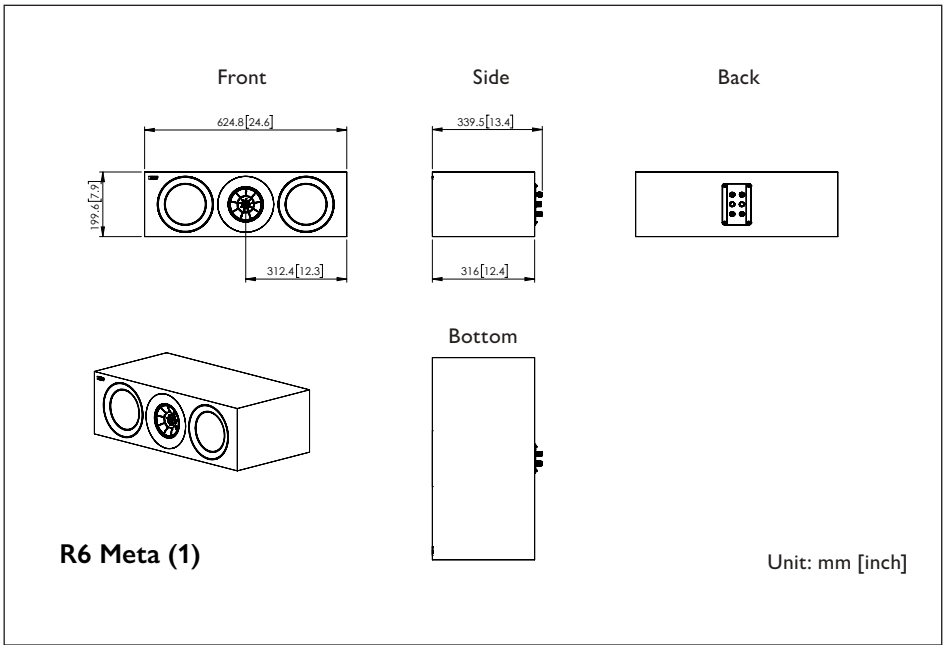

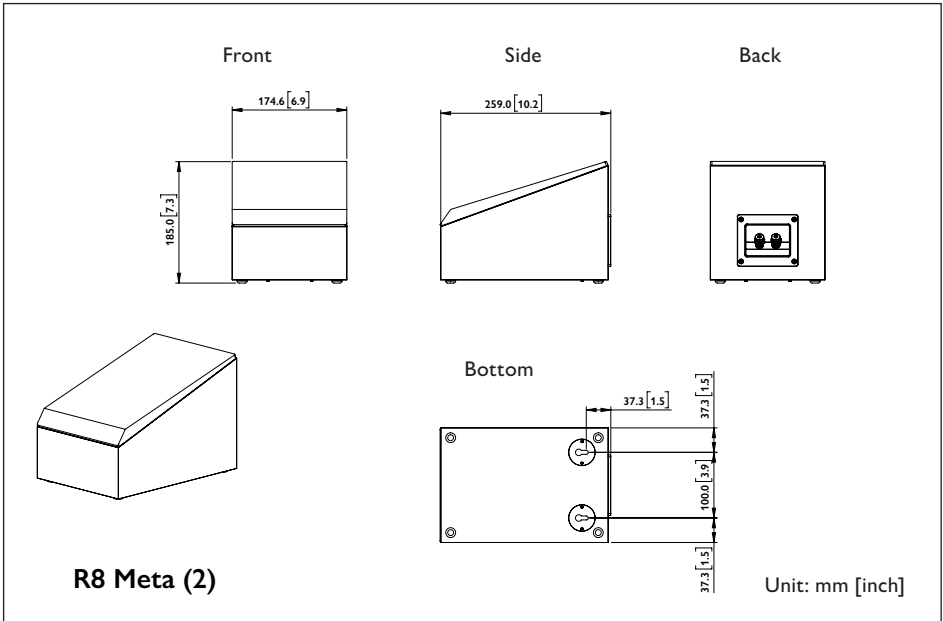
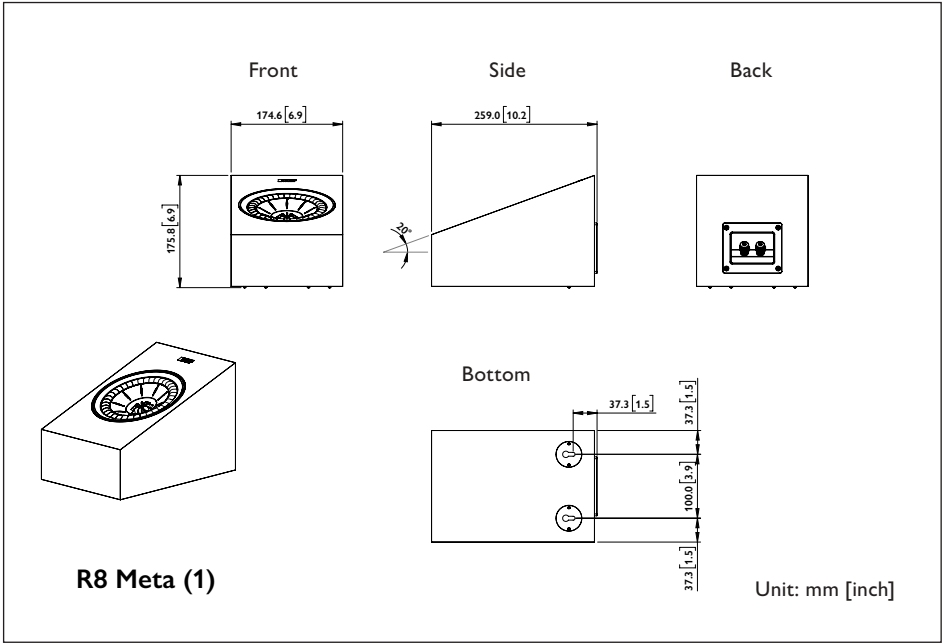

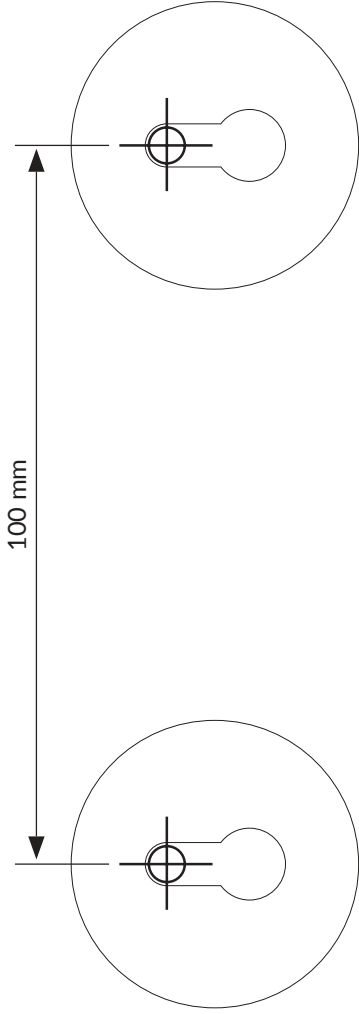

R8 Meta
Wall Mounting Template

128 mm x 180 mm (H x W)

For more support, please visit [kef.com](https://www.kef.com)

Version: R22-01-2410