



audio-technica

AT-LP8X

Semi-Automatic Direct-Drive Turntable

User Manual

English

Introduction

This product can be used only in the countries where the product is sold. Make sure that the operating voltage and plug of the power cable of the product are correct for the country you live in.

Safety precautions

Although this product was designed to be used safely, failing to use it correctly may result in an accident. To ensure safety, observe all warnings and cautions while using the product.

Important information

Warning

To prevent fire or shock hazard, do not expose this apparatus to rain or moisture.

Caution

- Do not expose this apparatus to drips or splashes.
- To avoid electric shock, do not open the cabinet.
- Refer servicing to qualified personnel only.
- Do not expose this apparatus to excessive heat such as sunshine, fire or the like.
- Do not subject this apparatus to strong impact.
- This apparatus should be located close enough to the AC outlet so that you can easily grasp the power cord plug at any time.
- In case of emergency, disconnect the power cord plug of this apparatus quickly.
- Do not place any objects filled with liquids, such as vases, on this apparatus.
- To prevent fire, do not place any naked flame sources (such as lighted candles) on this apparatus.
- Do not install this apparatus in a confined space such as a bookcase or similar unit.
- Install this apparatus only in the place where ventilation is good.
- This apparatus with Class I construction shall be connected to the AC outlet with a protective grounding connection.
- The rating label is put on the bottom of this apparatus.

For customers in the USA/Canada

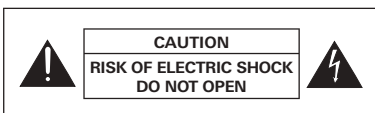

Safety precautions

Caution

To prevent electric shock, do not remove the cover. There are no user-serviceable parts inside. Internal adjustments are for qualified professionals only. Refer all servicing to qualified service personnel.



The lightning flash with arrowhead symbol, within an equilateral triangle, is intended to alert the user to the presence of uninsulated "dangerous voltage" within the product's enclosure that may be of sufficient magnitude to constitute a risk of shock to persons.



The exclamation point symbol within an equilateral triangle is intended to alert the user to the presence of important operating and maintenance (servicing) instructions in the literature accompanying the product.

FCC Notice

Warning

This device complies with Part 15 of the FCC Rules. Operation is subject to the following two conditions: (1) This device may not cause harmful interference, and (2) this device must accept any interference received, including interference that may cause undesired operation.

Caution

You are cautioned that any changes or modifications not expressly approved in this manual could void your authority to operate this equipment.

Note: This equipment has been tested and found to comply with the limits for a Class B digital device, pursuant to part 15 of the FCC Rules. These limits are designed to provide reasonable protection against harmful interference in a residential installation. This equipment generates, uses and can radiate radio frequency energy and, if not installed and used in accordance with the instructions, may cause harmful interference to radio communications. However, there is no guarantee that interference will not occur in a particular installation. If this equipment does cause harmful interference to radio or television reception, which can be determined by turning the equipment off and on, the user is encouraged to try to correct the interference by one or more of the following measures:

- Reorient or relocate the receiving antenna.
- Increase the separation between the equipment and receiver.
- Connect the equipment into an outlet on a circuit different from that to which the receiver is connected.
- Consult the dealer or an experienced radio/TV technician for help.

Contact

Responsible Company: Audio-Technica U.S., Inc.
Address: 1221 Commerce Drive, Stow, Ohio 44224, USA
Tel: 330-686-2600

For customers in Canada

ISED statement

CAN ICES-003(B)/NMB-003(B)

Notes on use

Turntable body

- Do not set and use the product in locations that are considerably hot or humid, dirty, or subject to extreme vibrations.
- The product should be positioned on a flat, level surface.
- When opening or closing the dust cover, do so slowly. When closing the dust cover, close it completely.

Cartridge

- The stylus is extremely delicate. Handle with care.
- Attach the provided protector to the cartridge when the product is not in use.
- Do not touch the stylus of the cartridge with your finger.
- Do not allow the stylus to bump against the platter, rubber mat, or edge of the record.
- Be sure to attach the protector before placing the cartridge on the floor or a desk. Do not place the stylus against the floor or a desk. Doing so could damage, chip, or break the stylus.
- The cartridge of this product is not intended for DJs. Do not operate the product in any way that may damage the stylus, such as scratching (rubbing the record on the turntable by hand to produce sound).
- Do not apply lateral force to the stylus while it is on the record. Doing so could damage, chip, or break the stylus tip. The record could also be damaged.

Package contents

- Make sure that you have all the included items before using this product.
- If some items are missing or damaged, contact your local Audio-Technica dealer.
- After purchase, we suggest that you save all packaging materials for possible future storage, moving, or shipping.

1

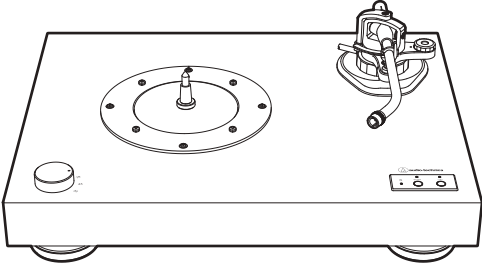

2

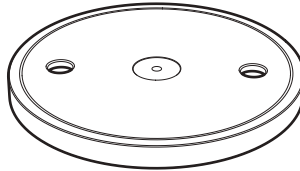

3

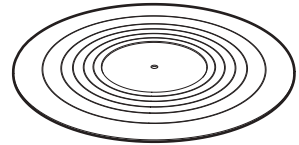

4

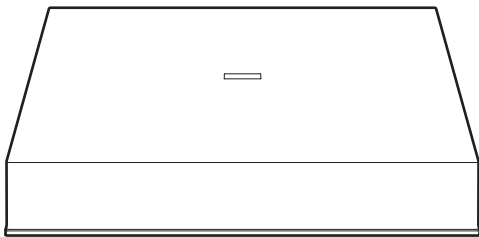

5

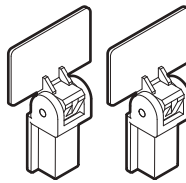

6

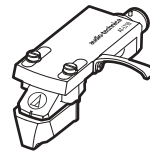

7



8



9



10

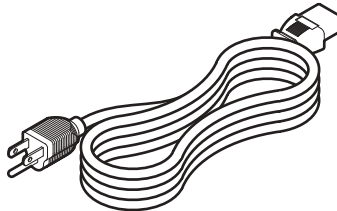

11

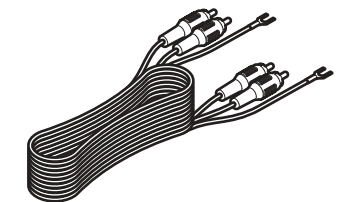

12

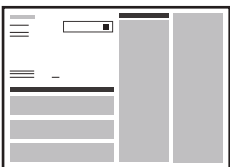

13



- 1 Turntable body
- 2 Platter
- 3 Rubber mat
- 4 Dust cover
- 5 Dust cover hinge
- 6 Headshell with cartridge

Package contents

- 7 Counterweight
- 8 Subcounterweight
- 9 45 RPM adapter
- 10 Power cable (Approx. 1.8 m (5.9'))
- 11 RCA audio cable (Approx. 1.0 m (3.3'))
- 12 Quick Start Guide
- 13 Caution Guide

Part names and functions

Top view

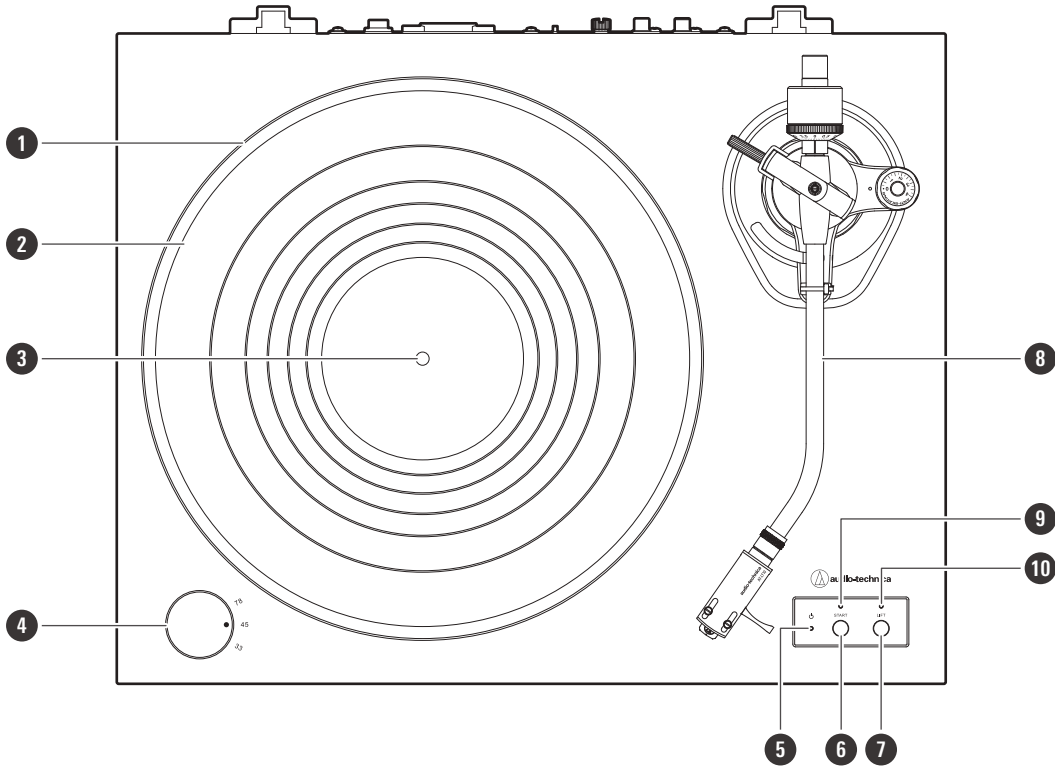

1 Platter

2 Rubber mat

3 Spindle

4 Control knob

Use to select the platter speed (33-1/3 RPM, 45 RPM, or 78 RPM).

5 Power supply indicator lamp

Indicates that power is on with a blue light.

6 START button

7 LIFT button

8 Tonearm

9 START indicator lamp

Indicates that the platter is spinning with a blue light. In addition, flashes blue when the auto-stop function is activated.

10 LIFT indicator lamp

Indicates that the tonearm lift is raised with a red light.

Rear view

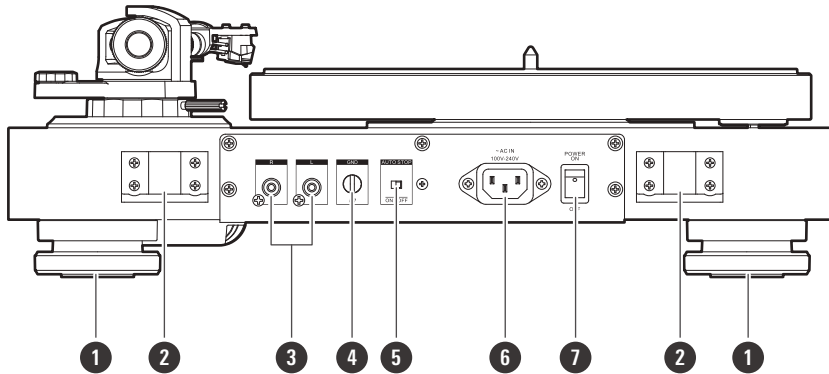

- 1 Foot**
Adjust the level of the product.
- 2 Dust cover hinge holder**
Attachment points for dust cover hinges.
- 3 Stereo output terminal**
Connect the RCA audio cable. Connect it to the amplifier's PHONO input jack. The red terminal is the right channel and the white terminal is the left channel.
- 4 Ground (earth) terminal**
Connect the amplifier's ground (earth) terminal to this terminal using the RCA audio cable's ground line.
- 5 AUTO STOP switch**
Turn the auto-stop function on/off.
- 6 Power input jack**
Insert the power cable here.
- 7 Power switch**
Turn on/off the power.

Tonearm

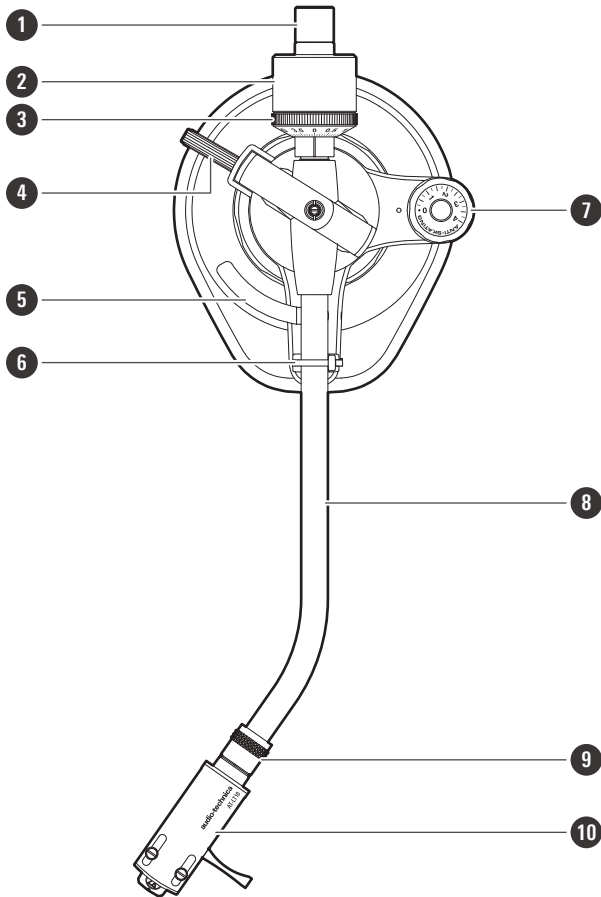

1 Subcounterweight

Attached when the tonearm's balance cannot be adjusted using the counterweight alone.

2 Counterweight

Balances the tonearm and adjusts to provide the proper tracking force.

3 Tracking force gauge ring

Use to adjust the tracking force.

4 Tonearm height adjustment lever

Move it to the left or right to adjust the tonearm's height.

5 Tonearm lift

Moves the tonearm vertically to and from the face of the record.

6 Tonearm rest with clamp

Use the clamp to secure the tonearm so that it does not move.

7 Anti-skate control dial

While the record is playing, a force acts on the stylus tip to pull it inward. This force can be counteracted by setting the same values for anti-skate and the tracking force.

8 Tonearm

Part names and functions

9 Locking ring

Rotate the ring to the left (counterclockwise) to secure the headshell. To remove the headshell, rotate the ring to the right.

10 Headshell and cartridge

The cartridge is attached to the headshell.

Preparation for use

Setting up the turntable

- Position the product on a level surface.
- To avoid the effects of vibrations and acoustic pressure, do not mount the product next to such items as speakers.
- The product may pick up radio static if placed next to a radio. Therefore, try to keep the product away from radios.
- If the product is near equipment (cell phone, etc.) that emits strong radio waves, noise may occur.

Leveling the turntable

After positioning the product where you want to use it, adjust the feet so that the product is level.

- Use a level (sold separately) as needed to ensure that the product is level.

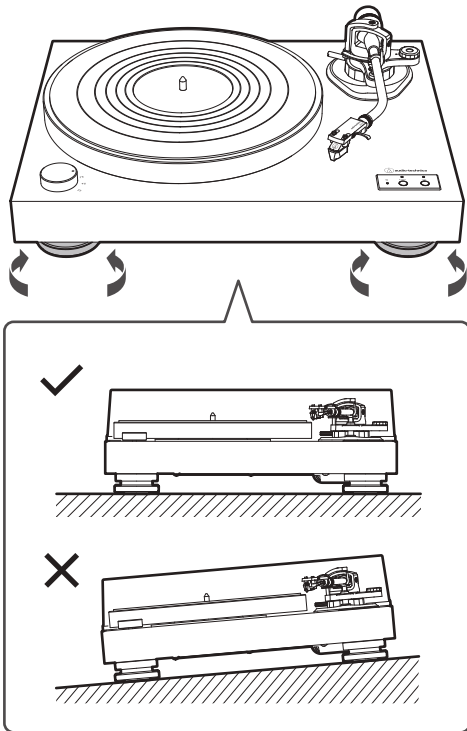

Placing the platter and the rubber mat

This product requires some assembly before using it for the first time.

- 1** With the power turned off, set the platter and the rubber mat on the spindle.

Preparation for use

- To avoid damaging the spindle when seating the platter, align the positions of the spindle and the platter's hole, and then slowly seat the platter.
- Make certain that the platter and rubber mat are fully seated on the spindle.

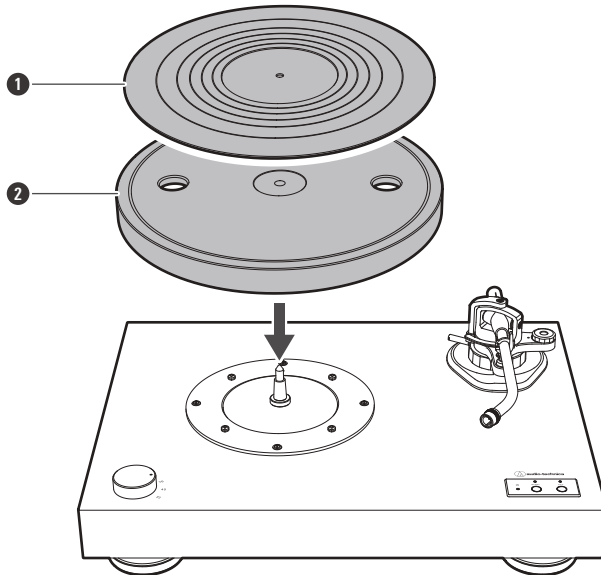

① Rubber mat

② Platter

Assembling the tonearm

1 Remove the cable tie used to secure the tonearm at the time of delivery.

- Use the clamp to temporarily secure the tonearm to the tonearm rest.

2 Insert the headshell into the tonearm.

- Hold the right and left edges of the headshell so that you do not damage the stylus or cut the cartridge's wires.

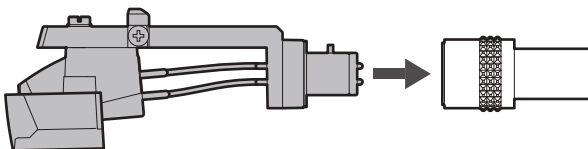

3 With the headshell inserted, turn the locking ring counterclockwise (to the left).

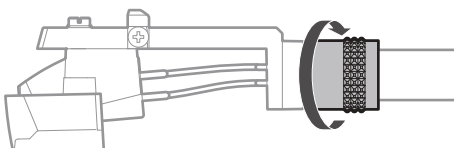

Preparation for use

- 4 Attach the counterweight to the back of the tonearm and slowly turn it counterclockwise (to the left).

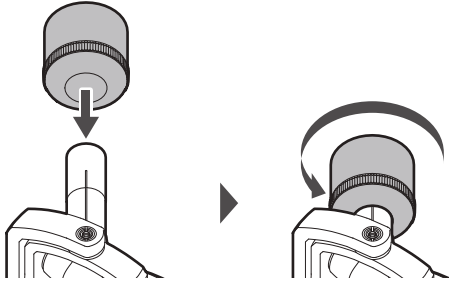

Tonearm balance and tracking force

In order for the cartridge to pick up sound correctly from the record's grooves, the tonearm's balance and tracking force must be adjusted to fit the specifications of the cartridge. If the tonearm's balance and tracking force are not properly adjusted, the record or the cartridge's stylus may become damaged.

- Do not drag the cartridge's stylus across the record or rubber mat when adjusting the tonearm's balance or tracking force. Doing so may damage the stylus.

Setting tonearm balance

- 1 Insert the power cable and turn on the power switch.

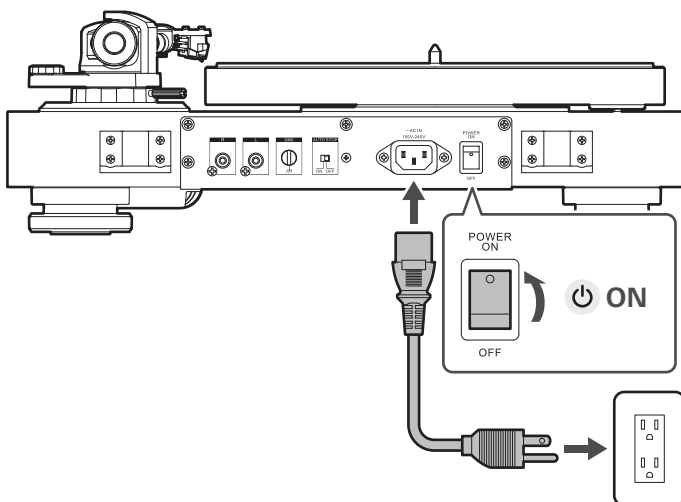

- 2 Remove the cartridge's protector.

Preparation for use

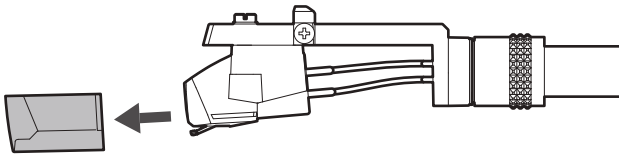

3 Release the clamp.

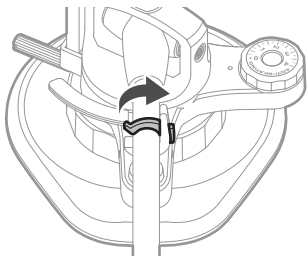

4 Move the tonearm over the rubber mat. Press the LIFT button while holding the headshell.

- Be careful not to allow the stylus tip to touch the rubber mat.

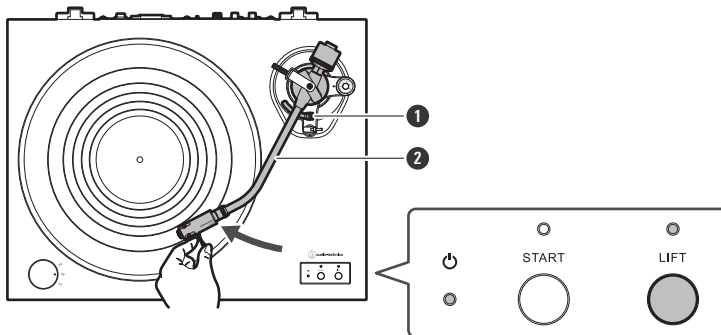

1 Tonearm lift

2 Tonearm

» The tonearm lift lowers (LIFT indicator lamp: off).

5 While still lightly holding the headshell, turn the counterweight to adjust the tonearm's balance.

- Adjust the balance so that the tonearm is level when you release the headshell.

Preparation for use

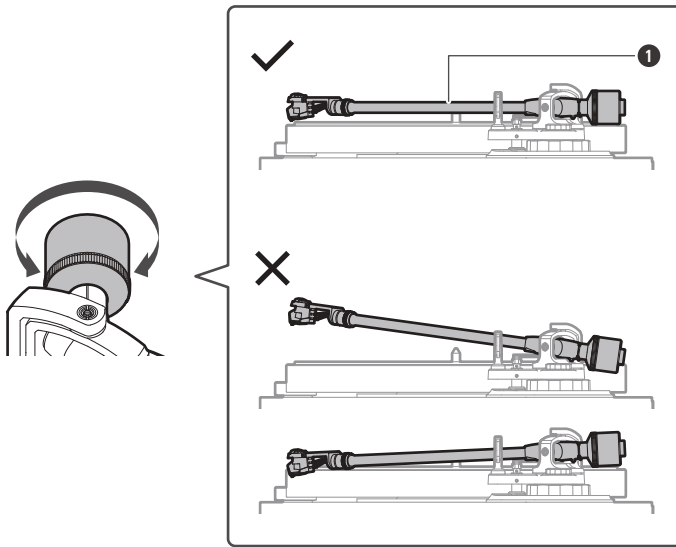

1 Tonearm

6 Return the tonearm to the tonearm rest.

7 Turn off the power switch.

How to attach the subcounterweight

Attach the subcounterweight when the tonearm's balance cannot be adjusted using the counterweight alone. This may be necessary if you are using another commercially available cartridge other than the one supplied with this product.

1 Attach the subcounterweight to the back of the tonearm.

- Attach the subcounterweight with the tonearm fixed to the armrest.

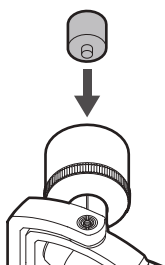

Setting tracking force

- 1** While supporting the counterweight so that it does not move, turn the tracking force gauge ring so that its "0" position lines up with the centerline on the back of the tonearm.

- The tracking force is not adjusted simply by turning the tracking force gauge ring.

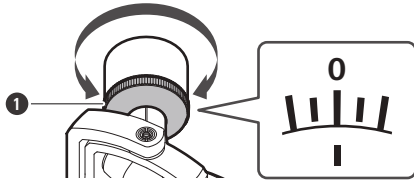

- 1** Tracking force gauge ring

- 2** Turn the counterweight and the tracking force gauge ring counterclockwise (to the left) to set the tracking force to the recommended tracking force value for the cartridge you are using.

- Refer to the cartridge maker's specifications for the recommended tracking force value.
- The tracking force value for the cartridge provided with this product is 2.0 g.

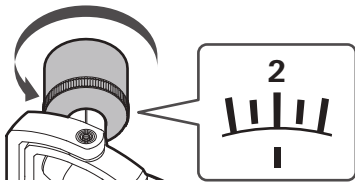

Setting the anti-skate adjustment

While the record is playing, a force acts on the stylus tip to pull it inward. This force can be counteracted by setting the same values for anti-skate and the tracking force.

- 1** Adjust the anti-skate control dial to have the same value as the tracking force value.

- The tracking force value for the cartridge provided with this product is 2.0 g.

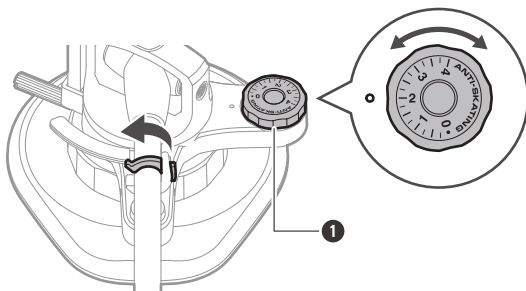

Preparation for use

- 1 Anti-skate control dial

Installing the dust cover

The dust cover is designed to protect the product's sensitive components when the product is not in use.

- 1 **Insert the dust cover hinges into the two dust cover hinge holders on the back of the body, and attach the dust cover to the dust cover hinges.**

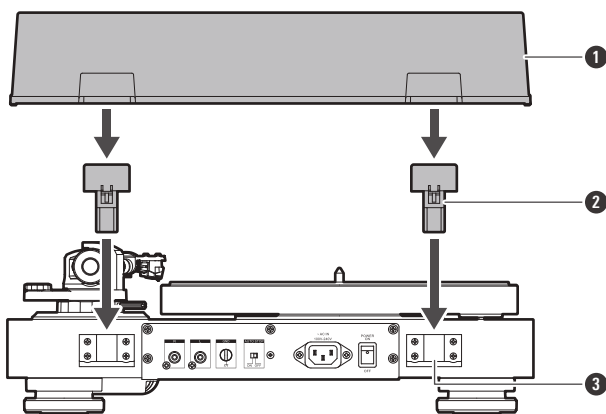

- 1 Dust cover
- 2 Dust cover hinge
- 3 Dust cover hinge holder



- When removing the dust cover, slowly pull the dust cover out from the dust cover hinges.

Using the product

This product does not have a built-in phono equalizer function. Connect the RCA audio cable to the PHONO input terminal of a phono equalizer or an amplifier with a built-in phono equalizer.

Connecting to a phono equalizer or an amplifier with built-in phono equalizer

The RCA audio cable's red jack is for the right (R) channel, and the white jack is for the left (L) channel.

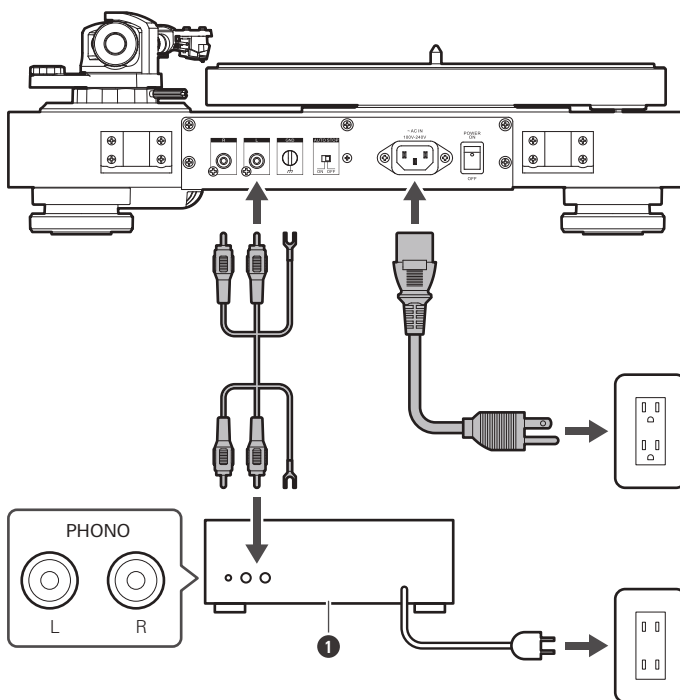

1 Phono equalizer or amplifier with built-in phono equalizer



- Depending on the equipment you are connecting, a ground (earth) terminal may exist near the phono input jack. If this is the case, connect to it using the ground line from the RCA audio cable. This will help prevent a low humming noise that might otherwise be heard during playback.
- If the power cable has a ground line, connect it before use (the shape of the power cable varies depending on the country in which it is sold).

Before playing a record

1 Plug the power cable into an outlet.

- Make sure that the power switch is off. If the power switch remains on while the power cable is connected, a standby current is always running through the product, even when it is not being used.

2 Remove the cartridge's protector.

Using the product

- Pull the protector straight forward to remove it.
- If the tonearm is fixed to the tonearm rest, remove the clamp.

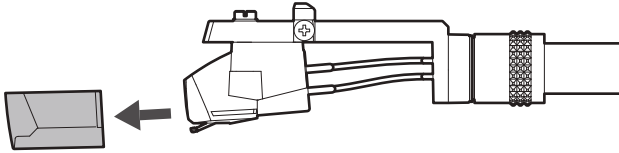

3 Place the record on the rubber mat so that the center hole aligns with the spindle.

At 33-1/3 RPM or 78 RPM

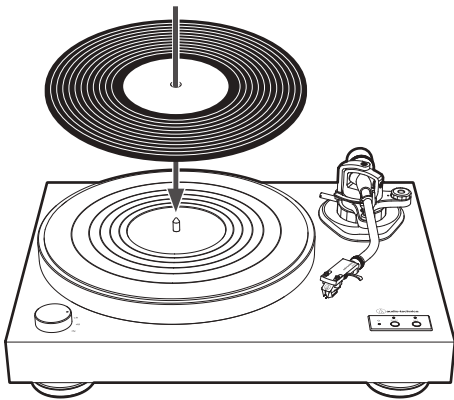

At 45 RPM

To play a 45 RPM record, attach the 45 RPM adapter.

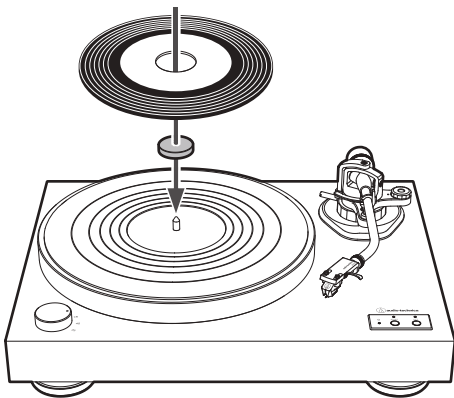

Playing a record

Lower the volume of the amplifier, active speakers, etc. sufficiently.

Using the product

1 Turn on the power switch.

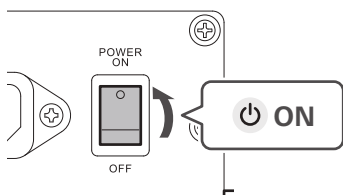

2 Use the control knob to select the speed and press the START button.

- Select "33" to play 33-1/3 RPM records, "45" to play 45 RPM records, and "78" to play 78 RPM records.

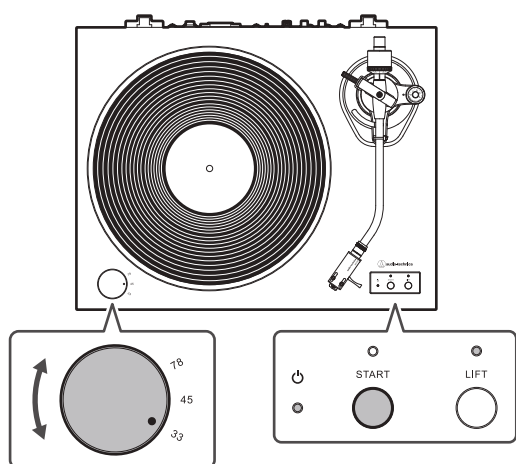

» The platter begins spinning (START indicator lamp: blue).

3 Position the tonearm over the desired location (groove) on the record.

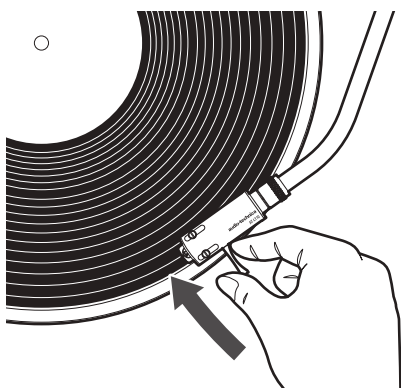

4 Press the LIFT button.

Using the product

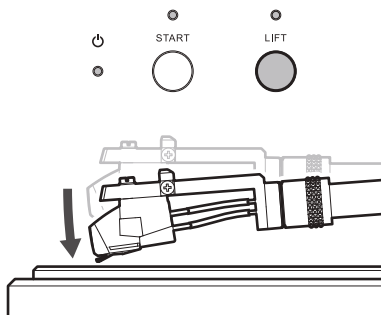

» The tonearm lift lowers (LIFT indicator lamp: off), the tonearm descends slowly onto the record, and play begins.



- Do not subject the product to strong impact during playback.

Pausing the record

1 Lower the volume of the amplifier, etc. sufficiently.

2 Press the LIFT button.

» The tonearm rises (LIFT indicator lamp: red).

Stopping the record

1 Lower the volume of the amplifier, etc. sufficiently.

2 Press the LIFT button.

» The tonearm rises (LIFT indicator lamp: red).

3 Return the tonearm to its original position and fix it with the clamp.

4 Press the START button.

» The platter slows down and rotation stops (START indicator lamp: off).

5 Attach the protector.

6 Remove the record after the platter has come to a complete stop.

Using the product



- If the rubber mat gets dirty, it can easily scratch the record, so remove the rubber mat periodically and wipe off any dust.
- To prevent the record from becoming scratched or warped, remove it after use.
- Do not use a disk stabilizer.
- Do not use a platter other than the one provided.
- This product is not intended for DJs. Do not touch the record or the platter while the record is playing. Do not operate the product in any way that may damage the stylus, such as scratching (rubbing the record on the turntable by hand to produce sound).
- Do not apply lateral force to the stylus while it is on the record. Doing so could damage, chip, or break the stylus tip. The record could also be damaged.

Auto-stop function

Once the record has played through to the end, this function automatically raises the tonearm and stops the platter from spinning.

- The START indicator lamp flashes blue.
- You can turn this function on or off using the AUTO STOP switch on the back of the turntable body (it is turned on by default).

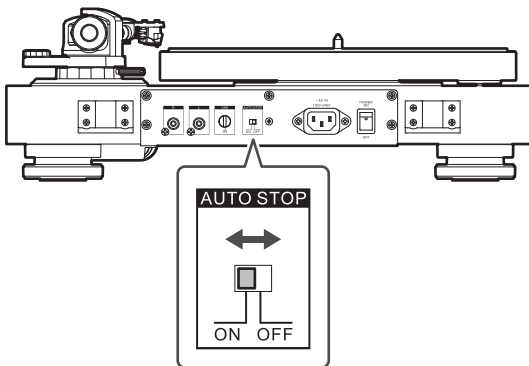

- The auto-stop function may not properly work on some records, such as 12-inch singles and SP records.
- If you cannot play some records through to the end, turn off the auto-stop function before using.

Care

Turntable body

- When the turntable body is dirty or dusty, first turn off the power switch, disconnect the power cable, and then wipe off the dirt and dust with a soft, dry cloth.
- Do not use benzenes, thinners, etc.
- If the rubber mat gets dirty, it can easily scratch the record, so remove the rubber mat periodically and wipe off any dust.
- When storing the product for a long time, first turn off the power switch, disconnect the power cable from the outlet, and then wrap the equipment in plastic; do not allow it to become damp.

Cleaning the stylus tip of the cartridge/record

- If dirt and grime are stuck to the stylus tip, clean it as needed. During cleaning, be sure to first turn off the power switch, and then disconnect the product's power cable from the outlet.
- We recommend using a stylus cleaner (sold separately by Audio-Technica) if the stylus tip is considerably dirty. Clean the stylus tip by moving the brush from the rear to the front of the stylus tip.
- For more details on record and stylus cleaners (sold separately by Audio-Technica), please visit the Audio-Technica website (<https://www.audio-technica.com/>).

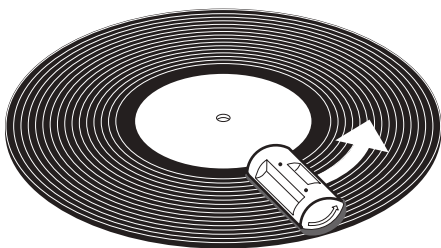
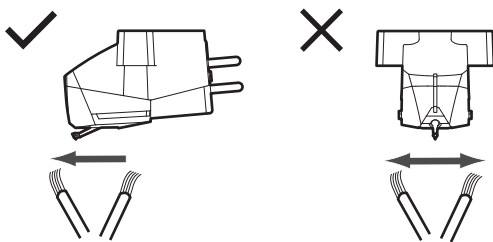

Replacing the stylus

Removing the stylus

- In addition to the deterioration of sound quality, records may also be damaged as the stylus tip of the cartridge wears down.
- As a rule of thumb, replace the stylus after 300 hours of use.
- Be sure to first turn off the power switch, and then disconnect the product's power cable from the outlet.
- When replacing the stylus, hold the headshell and the cartridge body firmly.

1 Release the headshell from the tonearm.

- Fix the tonearm with the clamp and then remove the headshell gently.

2 After removing the cartridge's protector, remove the stylus by pulling it in the direction of the arrow without touching the cantilever, stylus tip, or magnet.

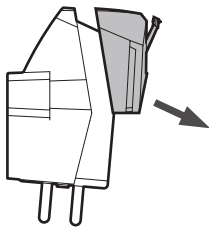

- Do not touch the cantilever, stylus tip, or magnet of the replacement stylus.

Installing a new replacement stylus

1 Mount the new replacement stylus to the cartridge.

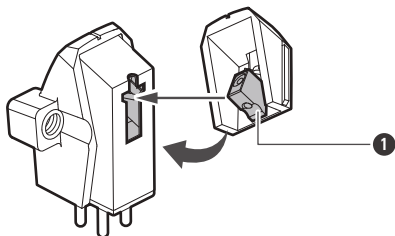

- 1 Align the position of the inner protrusion.

2 Mount the headshell onto the tonearm.



- Do not touch the cantilever, stylus tip, or magnet of the replacement stylus.

Replacing a cartridge

- Refer to the user manual for the cartridge that you will be using if you are replacing the cartridge with a commercially available one.
- After you replace the old cartridge with a new one, you must readjust the overhang and the tonearm's balance and tracking force.

1 Release the headshell from the tonearm.

- Use the clamp to secure the tonearm and then remove the headshell gently.

2 Remove the stylus from the cartridge.

3 Remove the lead tips.

- Be careful not to damage the lead tips.

4 Using a commercially sold, non-metallic slotted screwdriver, remove the installation screws, and then remove the cartridge from the headshell.

5 Refer to the user manual for the new cartridge for mounting instructions and connecting to the lead tips.

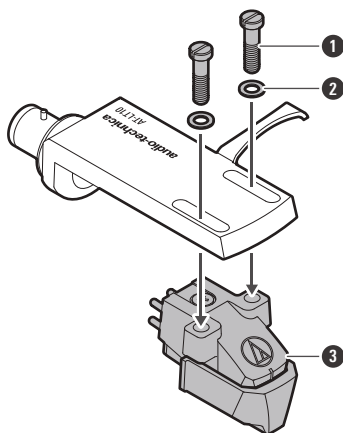

- ① Installation screw
- ② Plastic washer
- ③ Cartridge

6 Using a commercially sold, non-magnetic slotted screwdriver, loosen both of the installation screws, and then adjust the overhang.

- Refer to "Adjusting the overhang" (p. 30).
- After the adjustments are complete, tighten the screws securely.

7 Attach the headshell to the tonearm.

Replacing a cartridge

8 Adjust the tonearm balance and tracking force.

- Refer to "Setting tonearm balance" (p. 14) and "Setting tracking force" (p. 17) to adjust them.

Adjusting the tonearm's height

When installing a cartridge other than the one provided, you must maintain a suitable distance between the cartridge and the surface of the record. Place the stylus tip with recommended tracking force on the record and confirm that the tonearm is parallel to the record's surface. If it is not parallel, adjust the height of the tonearm.

- At the time of purchase, the tonearm height adjustment lever is directly below the counterweight.

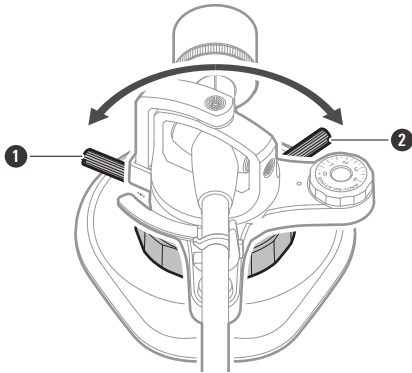

- 1 If you move the tonearm height adjustment lever to the left, it lowers the tonearm.
- 2 If you move the tonearm height adjustment lever to the right, it raises the tonearm.

1 Turn the tonearm height adjustment lever to unlock it.

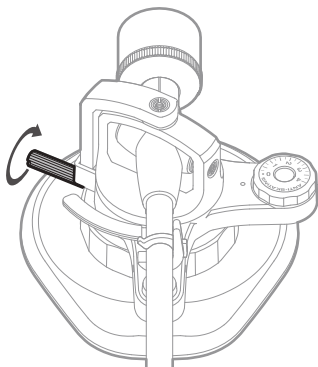

2 Move the tonearm height adjustment lever to the left or right to adjust the tonearm's height.

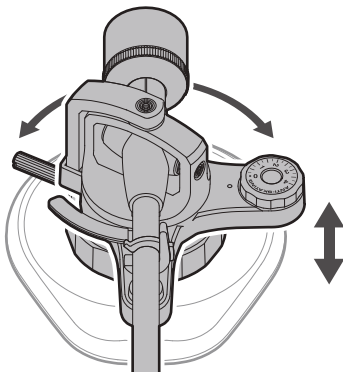

Adjusting the tonearm's height

- 3** Turn the tonearm height adjustment lever to lock it in place.

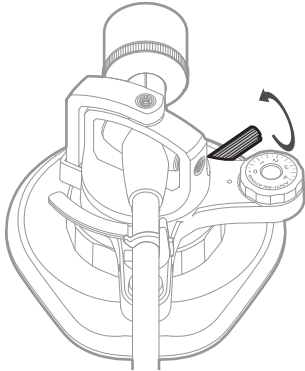

- 4** Place a record on the rubber mat, and position the tonearm over the record. Lower the stylus tip to the record surface, and confirm that the tonearm is parallel to the record's surface.

Adjusting the overhang

- The position of the cartridge must be accurately determined (adjusting the overhang) when mounting a cartridge or headshell other than the one provided.
- Please use a printer to print (at actual size) the PDF for the Overhang Adjustment Guide available on our website.

When the turntable is moved

Using the product's original packaging materials, pack the turntable in the reverse order of unpacking it. If you do not have the original packaging materials, take the following measures:

- After turning off the power switch, disconnect the power cable from the outlet, remove the rubber mat and platter, and then wrap the turntable body so that it does not get damaged. If the product is moved while the platter is still seated, it may damage the spindle.
- Make sure the tonearm lift control lever is lowered.
- Use the tonearm rest clamp to secure the tonearm so that it does not move.
- Remove the counterweight.
- Remove the headshell from the tonearm with the cartridge's protector attached, and then wrap the entire headshell assembly so that it does not get damaged.
- Wrap the turntable body with paper or a soft cloth so that it does not get damaged.

Troubleshooting

? The platter does not spin

- Is the power cable connected to the outlet? Connect the power cable to the outlet.

? The platter spins, but there is no sound or the volume is not loud enough

- Is the cartridge's protector still attached to the cartridge? Remove the cartridge's protector.
- Is the tonearm lifted? Lower the tonearm.
- Are the function settings and input for connected equipment (amplifier, etc.) selected correctly? Check whether the settings for the connected equipment are correct.
- Is the stylus damaged? Check the stylus and replace it, if necessary.
- Is the replacement stylus placed correctly on the tonearm? Check the replacement stylus and adjust it, if necessary.
- Is the tracking force set too heavy? Adjust the tracking force.

? The stylus skips

- Is the tracking force set too light or too heavy? Adjust the tracking force.
- Is the anti-skate set improperly? Verify anti-skate is set for same value as cartridge tracking force.
- Is the record warped? Check the record.
- Is the record scratched? Check the record.
- Is the stylus dirty? Excessive accumulation of dirt and dust on the stylus affects the record's playback quality.

? There is howling

- Is the product picking up excessive vibrations from the floor, surfaces of the walls, or nearby speakers? Decrease the vibrations or mount the product on a surface that is not subject to the effects of vibrations.
- Is the product mounted on an unstable surface? Check whether the surface on which the product is mounted is suitable.

? There is noise when the record is playing

- Is there dust on the stylus tip of the cartridge? If dust is stuck to the stylus tip, clean it with a commercially sold brush.

① The sound when the record is playing is either too fast or too slow

- Are the speed settings for the product correct? Use the control knob to select the correct speed for the type of record being played.

① Humming noise is heard during playback

- Is the ground line connected correctly? Make sure the ground line is properly connected.
- If the noise continues, remove the ground line. This may reduce the noise.
- Is the headshell attached to the tonearm firmly? Make sure the locking ring is tight.

Dimensions

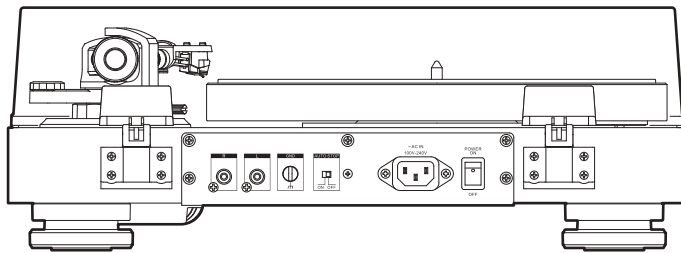
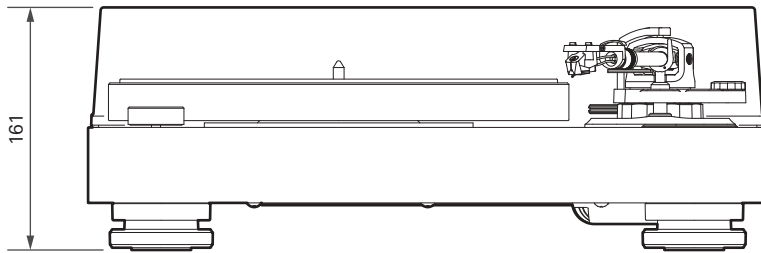
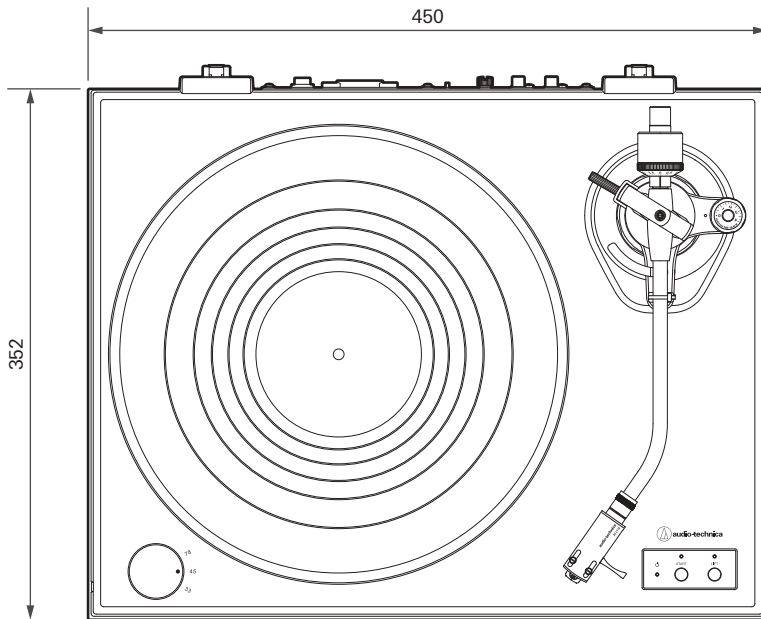

(Unit: mm)

Dimensions

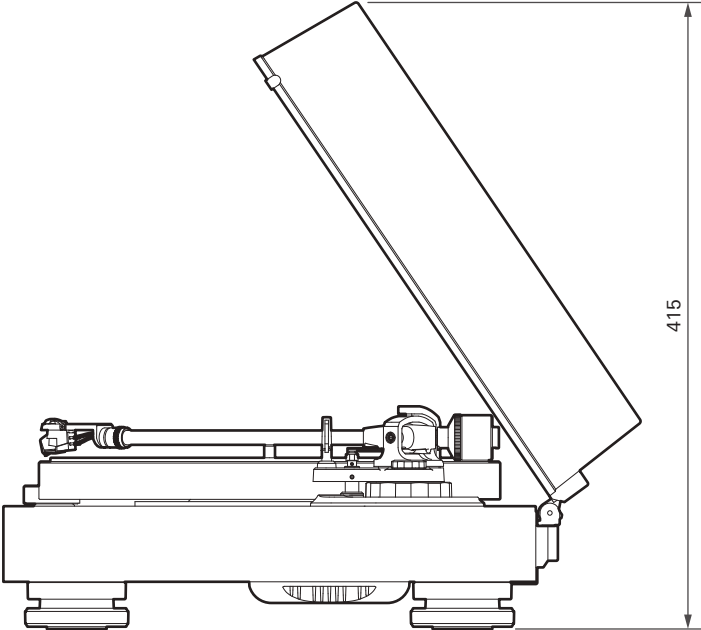

(Unit: mm)

Specifications

Turntable specifications

Motor	DC servo motor
Drive method	Direct drive method
Speeds	33-1/3 RPM, 45 RPM or 78 RPM
Turntable platter	Die-cast aluminum, rubber damper
Starting torque	1.0 kgf.cm (0.87 lbf.in)
Braking method	Electronic braking
Wow and flutter	< 0.1% (WTD) @3 kHz (JIS)
Signal-to-noise ratio	> 60 dB
Output levels	PHONO: 4.0 mV nominal at 1 kHz, 5 cm/sec

Tonearm specifications

Type	Static balanced J-shaped tonearm
Effective length	247 mm (9.7")
Overhang	15 mm (0.59")
Maximum tracking error angle	Less than 2.0°
Stylus pressure adjustment range	0.0 to 4.0 g (0.0 to 0.14 oz)
Applicable cartridge weight range (including headshell)	14.0 to 20.0 g (0.49 to 0.71 oz) (17.5 to 23.5 g (0.62 to 0.83 oz) when using subcounterweight)

Cartridge and headshell specifications

Cartridge model	AT-VM95E BK
Cartridge type	VM
Recommended load impedance	47,000 ohms
Output voltage	4.0 mV (mV at 1 kHz, 5 cm/sec)
Stylus	0.3 × 0.7 mil bonded elliptical stylus
Cantilever	Aluminum pipe
Tracking force range	1.8 to 2.2 g (standard 2.0 g)
Cartridge weight	6.1 g (0.22 oz)
Headshell model	AT-LT10
Headshell weight	Approx. 10.7 g (0.38 oz) (including lead wires) Approx. 10.0 g (0.35 oz) (excluding lead wires)
Headshell overhang adjustment	+5.5 mm (0.22") to -2.5 mm (0.098") (when using AT-VM95E)

Specifications

General specifications

Dimensions	450 mm (18") × 352 mm (14") × 161 mm (6.3") (W × D × H)
Weight	Approx. 10.4 kg (23 lbs)
Power supply requirements	100 V, 50/60 Hz
Power consumption	8 W
Accessories	Dust cover, Rubber mat, Platter, Dust cover hinge, Counterweight, Subcounterweight, Headshell (AT-LT10) with VM stereo cartridge (AT-VM95E BK), 45 RPM adapter, RCA audio cable (Approx. 1.0 m (3.3')), Power cable (Approx. 1.8 m (5.9'))
Replacement stylus (sold separately)	AT-VMN95E BK
Replacement headshell (sold separately)	AT-LT10

- For product improvement, the product is subject to modification without notice.

株式会社オーディオテクニカ

〒194-8666 東京都町田市西成瀬2-46-1
www.audio-technica.co.jp

Audio-Technica Corporation

2-46-1 Nishi-naruse, Machida, Tokyo 194-8666, Japan
www.audio-technica.com
©2024 Audio-Technica Corporation
Global Support Contact: www.at-globalsupport.com