

InSinkErator® essentials



ES30

Garbage Disposal

Submittal Sheet

This model offers the following features and benefits:

- MAGNADRIVE™ 1/3 HP permanent magnet motor¹
- 1-Stage Grind: Reliable grind for everyday food scraps
- 3D Grind Zone: Engineered to quickly grind and rinse the disposal
- Lift & Latch® technology for simplified installation
- Power cord attached for hassle-free outlet connections
- Safe for use with properly maintained septic tanks

Sample Specification

Food Waste Disposer(s) shall be InSinkErator ES30, continuous feed, with 1/3 HP motor¹, galvanized steel grind components with two stainless steel lugs.

Warranty

2-year *We Come to You*® In-Home limited warranty²

Specifications

Type of Feed	Continuous
On/Off Control	Wall Switch
Motor	Single Phase
HP	1/3
Volts	120
HZ	60
Amp. (Avg. Load)	2.5A
Time Rating	Intermittent

Lubrication	Permanently Lubricated Upper & Lower Bearings
Shipping Weight (Approx.)	11.46 lb.
Overall Height	13.875"
Motor Protection	Automatic Reset
Drain Connection	1-1/2" cushioned slip joint
Dishwasher Drain Connection	Yes

¹ Laboratory measurement of peak horsepower output of motor, not the operational output at the disposal.

² The complete InSinkErator warranty is included in the Care & Use Booklet packed with each unit.

Dimensions

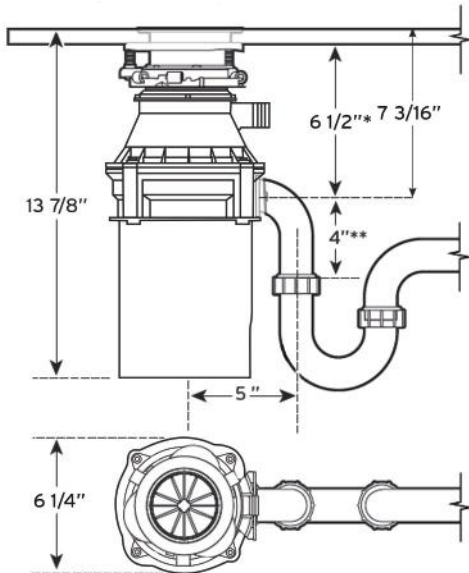

Job Specifications



Food waste is roughly 65-90% water. By using your disposal regularly, you can help divert food waste from landfills and reduce greenhouse gas emissions. Make sustainability a family affair by using your disposal. After all, the smallest changes can make the biggest impact.

1-800-558-5700
www.insinkerator.com