

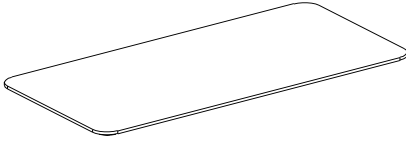

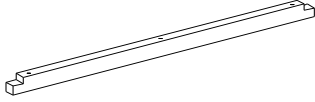

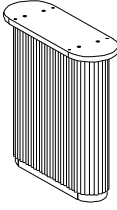

ASSEMBLY INSTRUCTIONS

SKU# 51031644

PARTS LIST

A	TABLE TOP X 1		<p>Before beginning</p> <p>1 - Carefully unpack and position the item on a clean, non-marring surface to assemble.</p> <p>2 - Read this Assembly Instructions from beginning to end before starting to assemble.</p> <p>3 - Take an inventory of the required parts to ensure all are available.</p> <p>4 - To prevent accidental choking hazards, keep all packing materials away from small children.</p> <p>5 - Only tighten hardware until ALL hardware are fully engaged on their locations. Overtighten bolts will damage the bolt threads.</p> <p>6 - Use only factory provided hardware to assemble. Unapproved hardware can damage product or jeopardize the structural integrity of the product.</p> <p>7 - The use of power tool to assemble is not recommended due to high risk of over-torque, which can damage the product.</p>
B	TOP SUPPORT X 1		
C	LEG X 2		

Z	HARDWARE	Z1	Z2	Z3	Z4	Z5	Z6		
									
		8X80MM X 3	8X50MM X 8	8X19X2MM X 11	8X12X2MM X 11	4X59MM X 1	X4 Adjustable Floor Glide (Pre-installed at the bottom of the legs)		

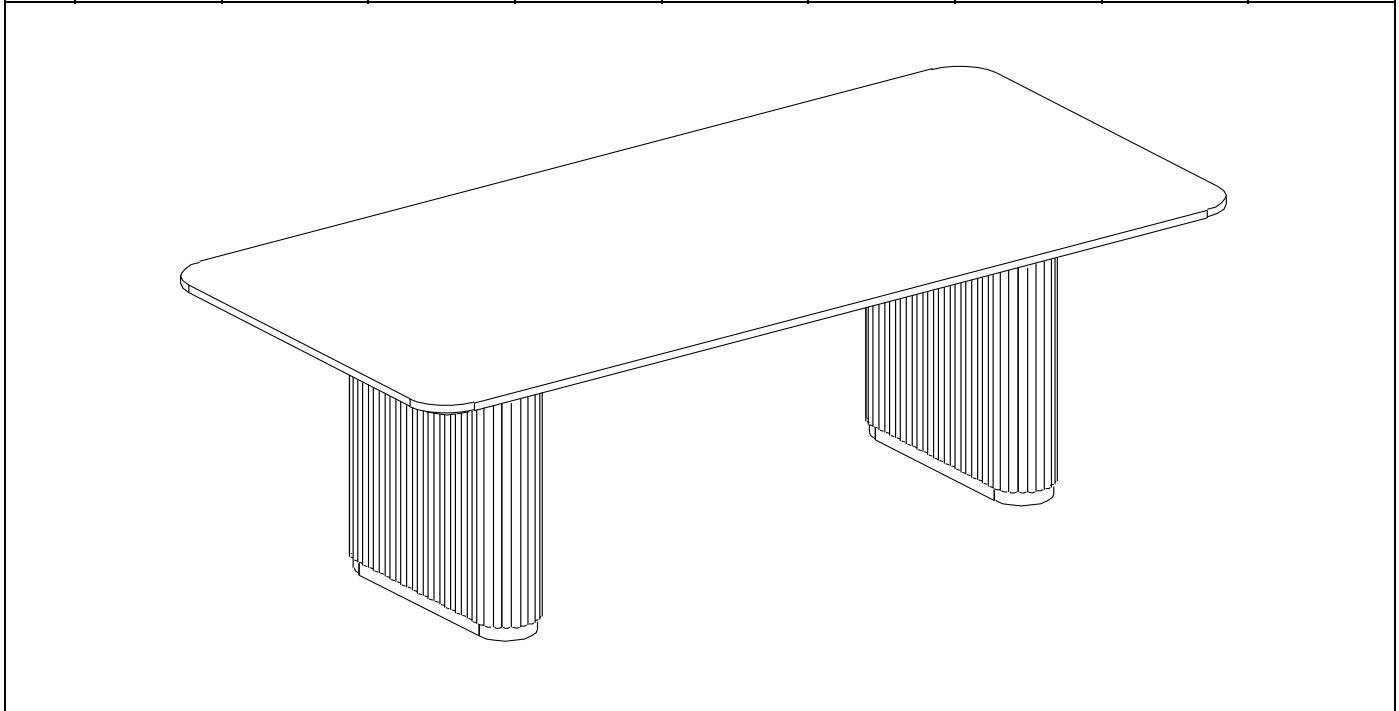

 <p>ASSEMBLY REQUIRES TWO PEOPLE</p>	 <p>15-MINUTE ASSEMBLY TIME</p>	 <p>KEEP INSTRUCTIONS FOR FUTURE USE</p>	
-----------------------------------------------------------------------------------------------------------------------------	------------------------------------------------------------------------------------------------------------------------	---------------------------------------------------------------------------------------------------------------------------------	---------------------------------------------------------------------------------------

ASSEMBLY INSTRUCTIONS

SKU# 51031644

1

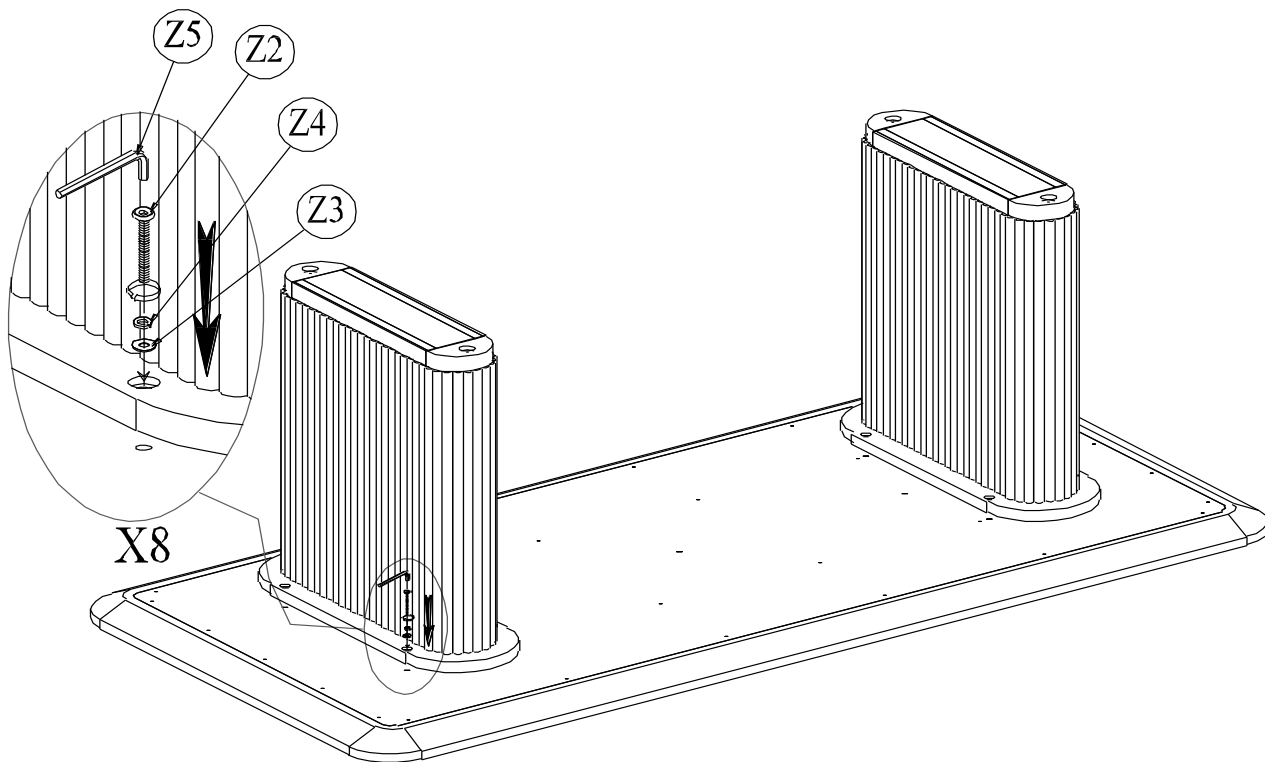

- Attach the Table Legs (C) into the Table Top (A).
- Using Allen Key (Z5) to tighten all Allen Bolts (Z2), Spring washers (Z4) and Washers (Z3).

2

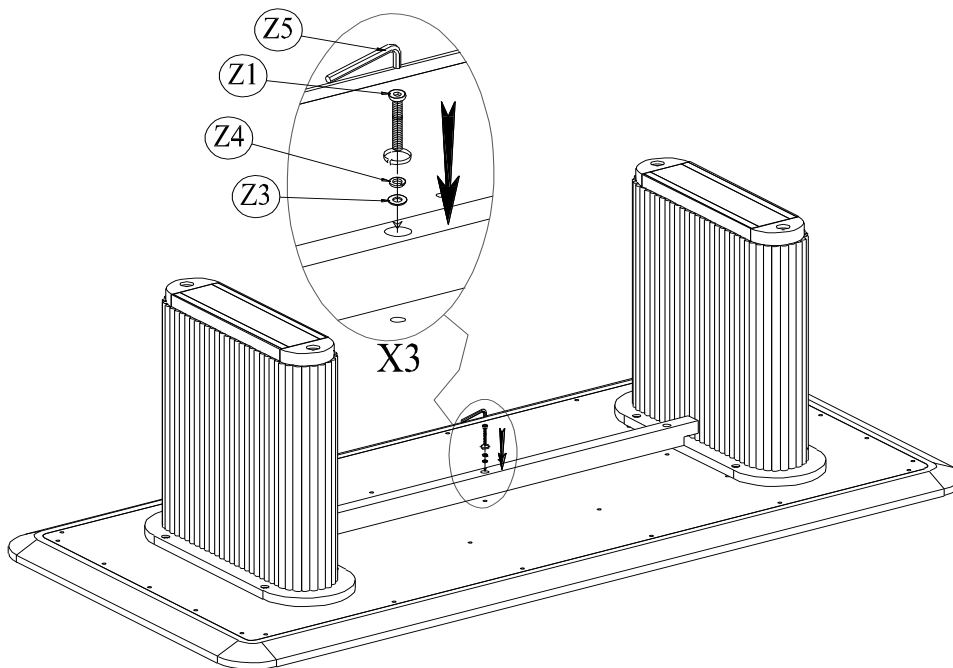

- Assemble the Top support (B) to the Table Top (A), Using Allen key (Z5) to tighten Allen Bolts (Z1), Spring Washers (Z4) and Washers (Z3).

ASSEMBLY INSTRUCTIONS

SKU# 51031644

3

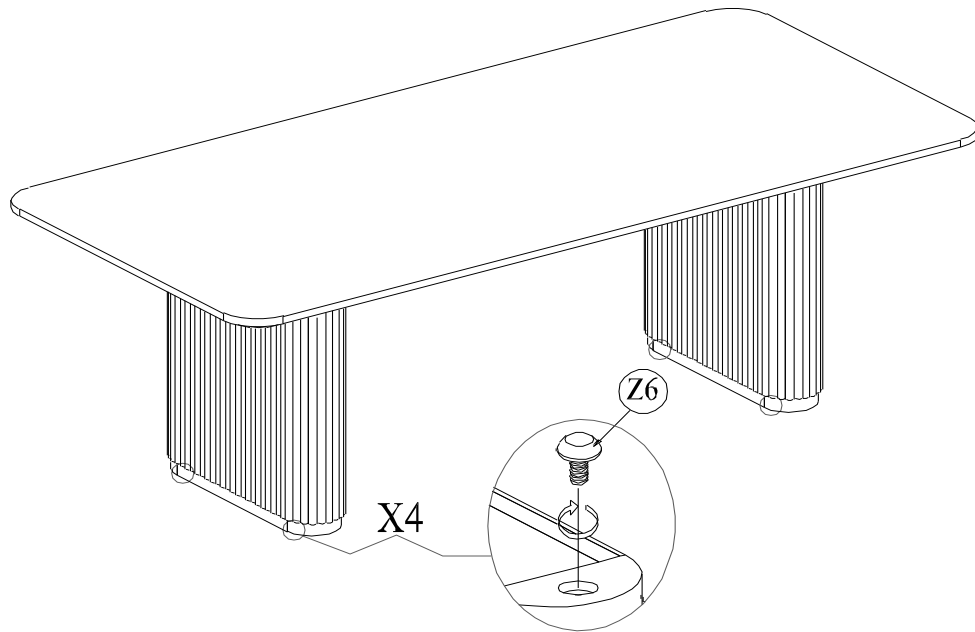

- With two people carefully turn the Table over and stand on its legs
- If the Table doesn't sit level, please adjust the Adjustable Floor Glide under the legs.
- Completed item.