

SETUP AND WIRING EXAMPLES

The following examples show some of the ways that KEF Architectural products may be used in your project. Included are wiring diagrams and the product settings required for each example.

PRODUCT SETTINGS

KASA500, as well as some Architectural subwoofers, have mode selection switches. The modes required are found with each example. For example, the following icon shows the switch when BYPASS is selected.

On  Bypass

NOTE: When C1200Q5b-THX is used with KASA500, ensure the CROSSOVER mode is set to bypass. When powered by a standard amplifier that does not feature a crossover, set the CROSSOVER mode to ON.

KASA500

KASA500 has DIP switches on the rear to adjust the line output (high pass filter) and the internal DSP (for KEF Architectural subwoofers). Please contact KEF Technical Support, or consult the DIP switch chart for advice on the best settings for your particular KEF speakers and subwoofers. Also note that KASA500 may be used in place of any 'generic' stereo amplifiers in these examples.

SUB/SAT AND SOUNDLIGHTS

These diagrams show examples of how KEF Architectural speakers may be utilised. Additional speaker pairs may be added, as long as good practices are observed in regards to nominal.

PASSIVE SUB/SAT SYSTEM (STEREO SUBWOOFERS)

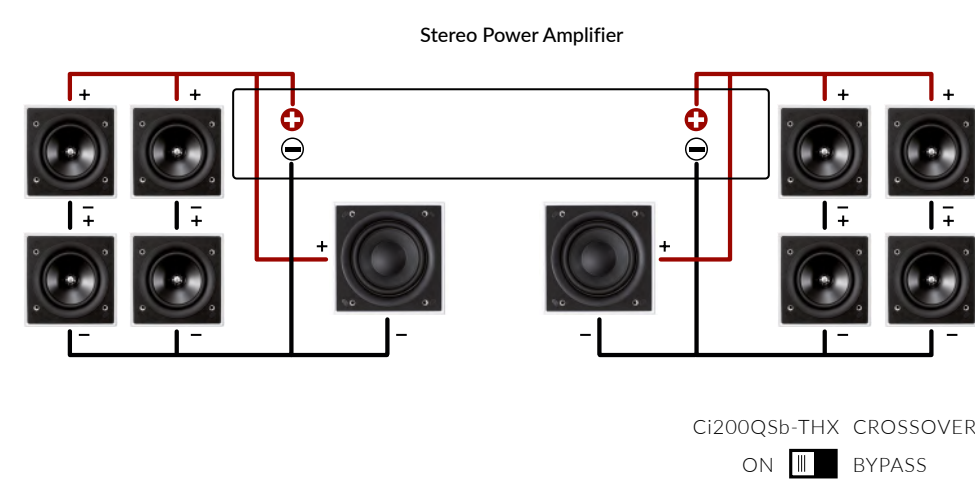

PASSIVE SUB/SAT SYSTEM (C1200TRb STEREO MODE)

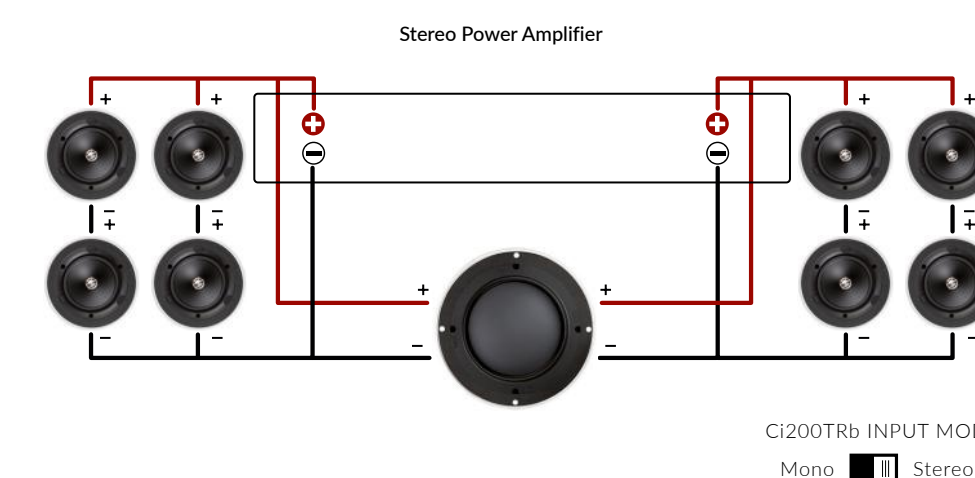

PASSIVE SUB/SAT SYSTEM (C1200TRb MONO MODE)

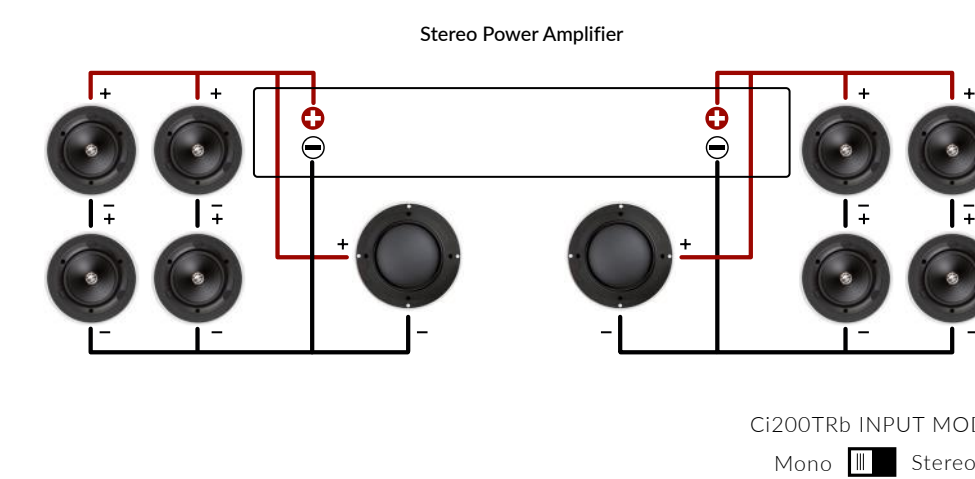

UNI-Q BENEFITS

KEF's signature Uni-Q Driver Array is a point source that places the tweeter at the exact acoustic centre of the midrange driver. The unique benefits of Uni-Q makes it the ideal solution for custom installation:

IN-CEILING LCR

By installing a KEF ceiling speaker as close to the front wall as possible, all listeners will hear the sound as if it is coming from the screen, rather than from above.



SIT ANYWHERE

Equal directivity sound of up to 160° delivers pinpoint imaging and effortlessly natural performance across a huge listening area, ensuring everybody shares the same experience.

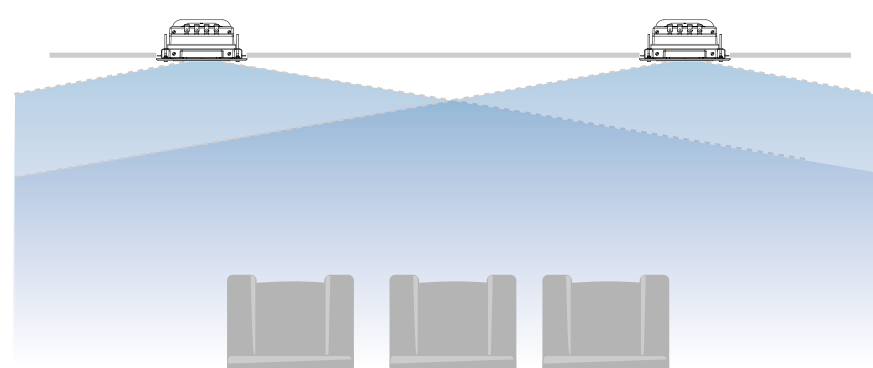

DOLBY ATMOS FOR ALL

The huge off-axis response ensures that everybody in the front row receives all the information from the rear Atmos channels, and everybody in the back row experiences everything from the front Atmos channels.

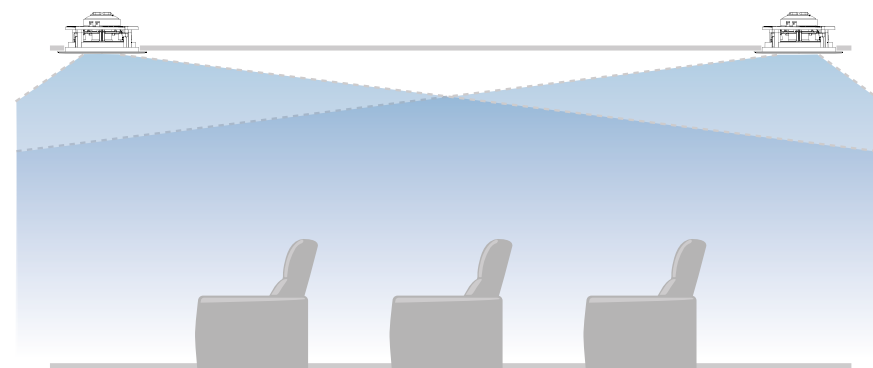

HIGH END SUB/SAT SYSTEM

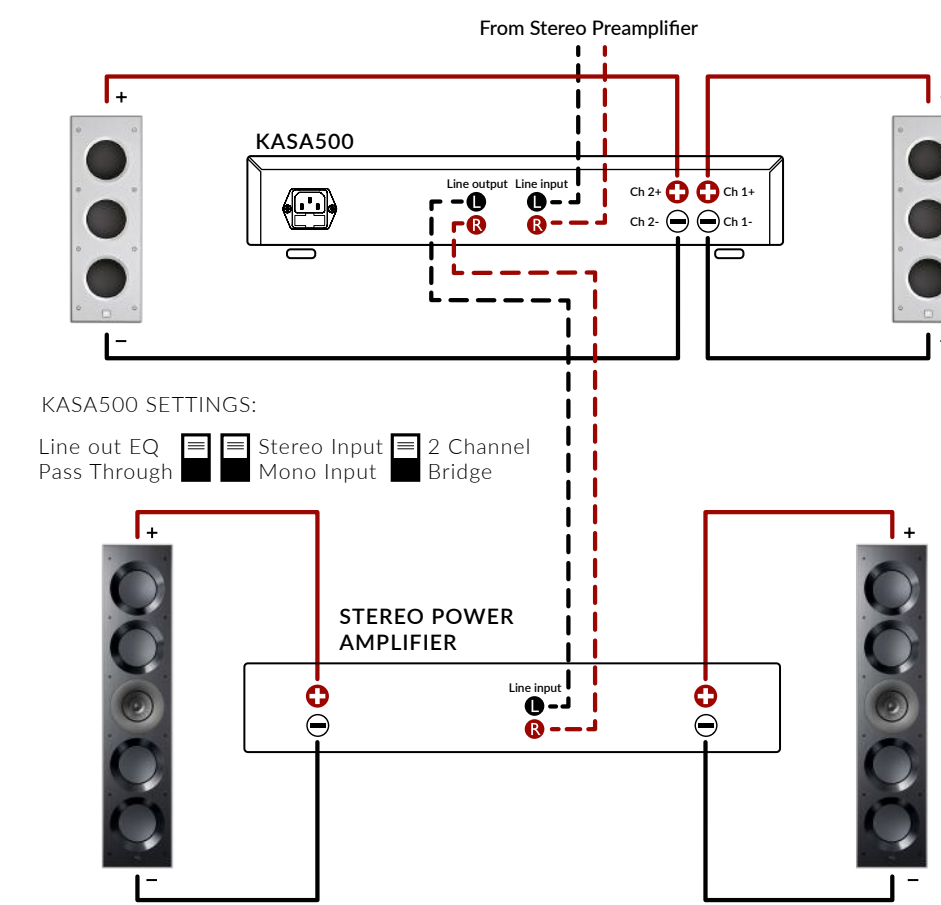

HIGH OUTPUT ACTIVE SUB/SAT SYSTEM

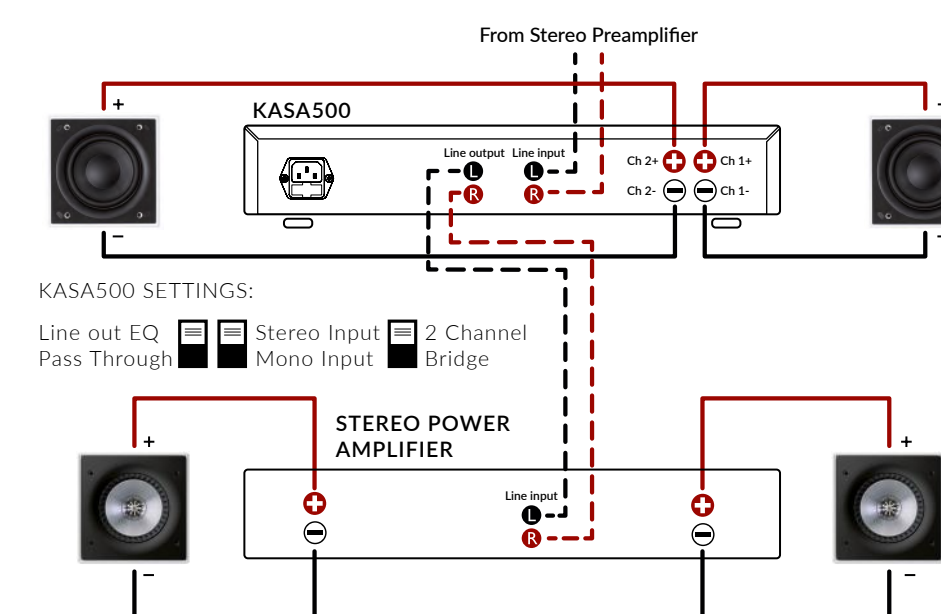

SINGLE SPEAKER SOLUTIONS

KEF has two ways of bringing phenomenal sound into situations where space is at a premium and only a single speaker will fit.

DUAL STEREO

The Dual Stereo special application loudspeakers feature two tweeters and a dual voice coil woofer. Stereo soundstage is created by combining the dispersion effect of the Tangerine Waveguide with asymmetrical tweeter placement, as illustrated below.

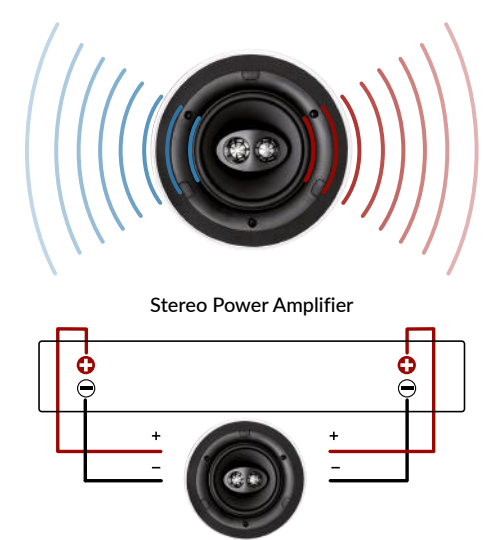

STEREO TO MONO TRANSFORMER (C1TR-SM)

The C1TR-SM converts a stereo amplifier signal into mono, allowing any KEF Architectural loudspeaker to deliver all the music from a single unit, with all the room filling benefit of Uni-Q.

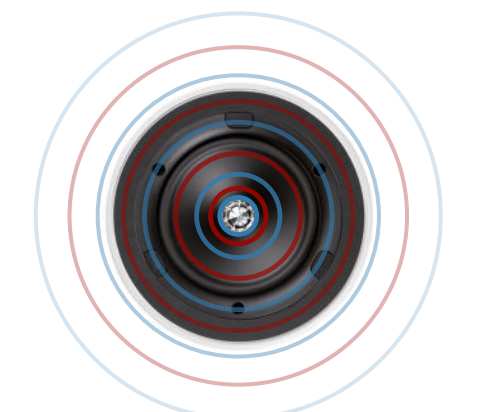

ACTIVE SUB/SAT SYSTEM 1

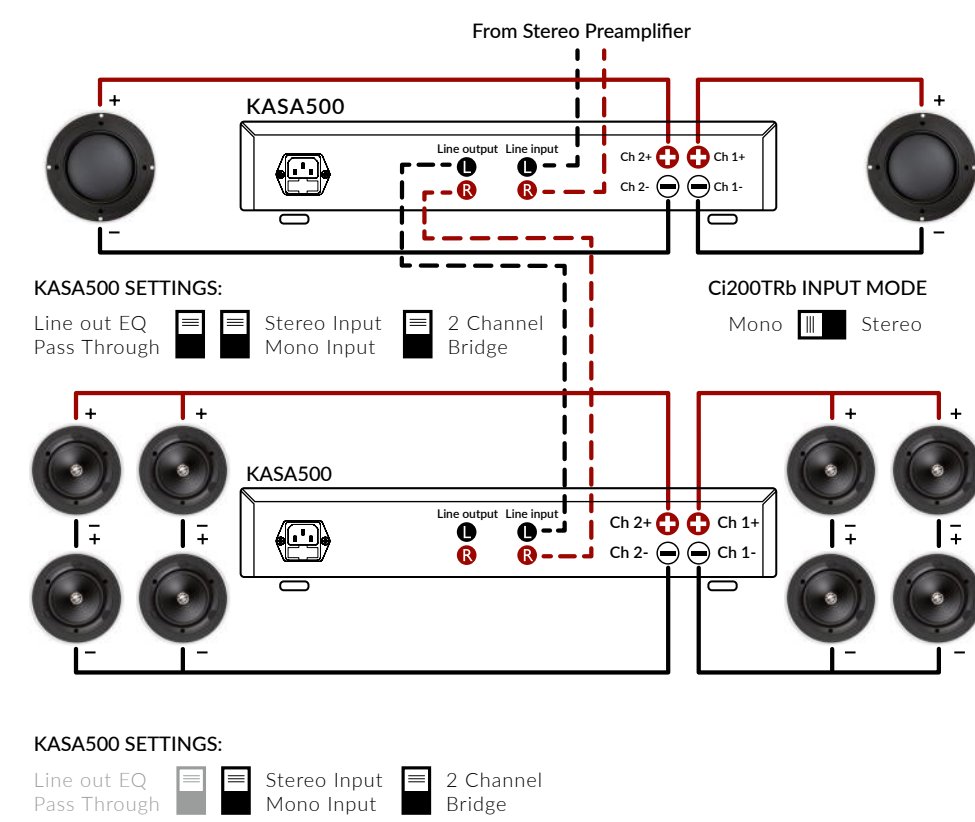

ACTIVE SUB/SAT SYSTEM 2

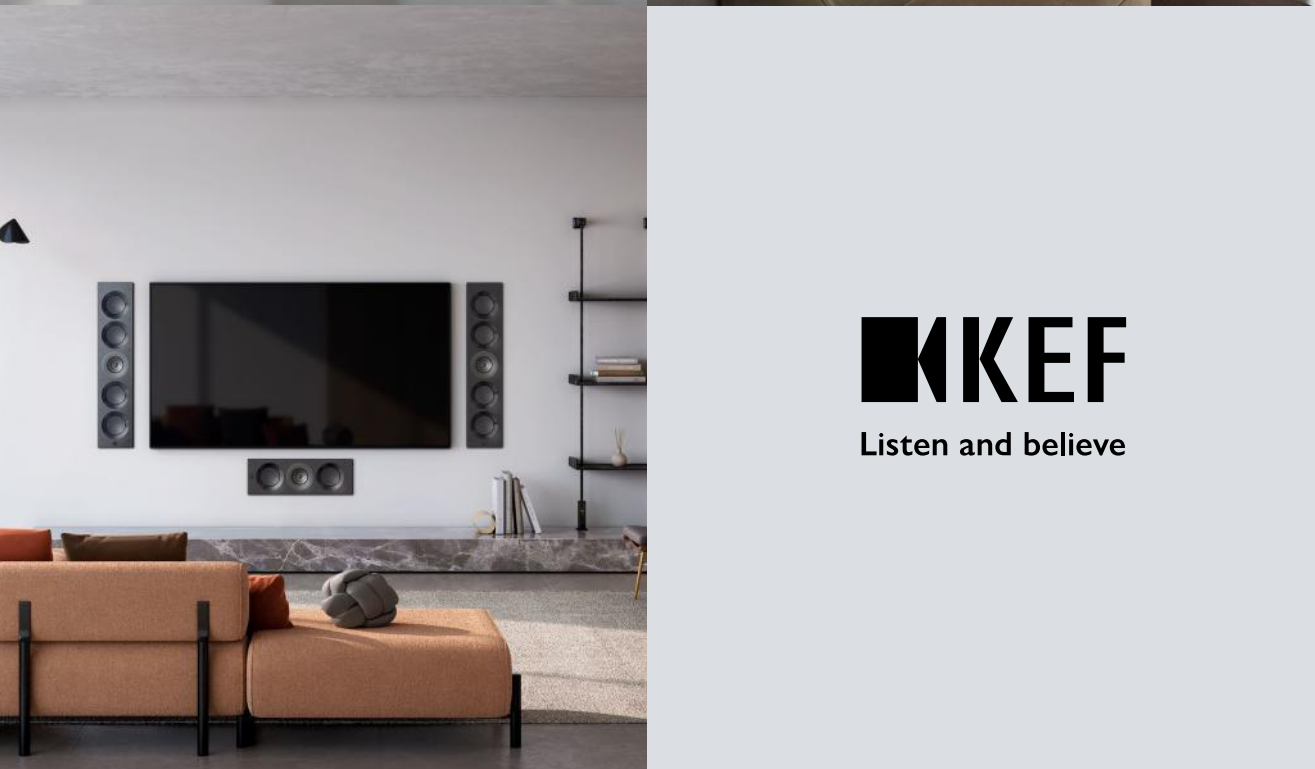
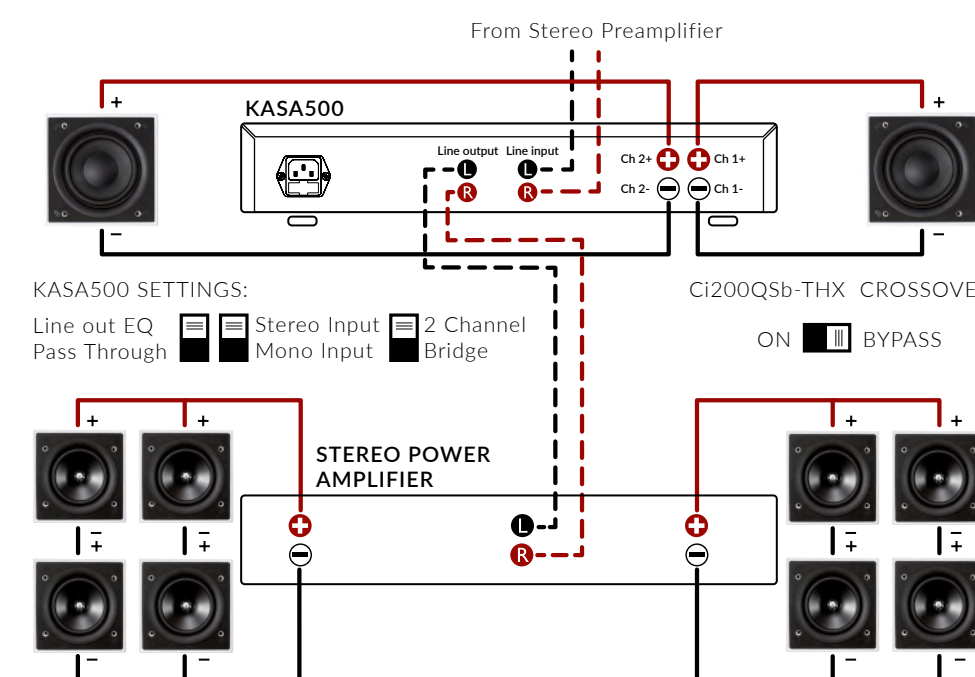

THX® CERTIFIED SUBWOOFERS

Three KEF Architectural subwoofers models, when combined with the KASA500 Audio System Amplifier, deliver THX® certified bass performance. For THX® Certified Select (rooms up to 2000 cubic feet), one KASA500 is used, whilst two KASA500 are needed for THX® Certified Ultra (rooms up to 3,000 cubic feet). The diagrams below show the number of subwoofers required, as well as the wiring and KASA500 settings.

C13160RLb-THX - THX CERTIFIED SELECT/ ULTRA

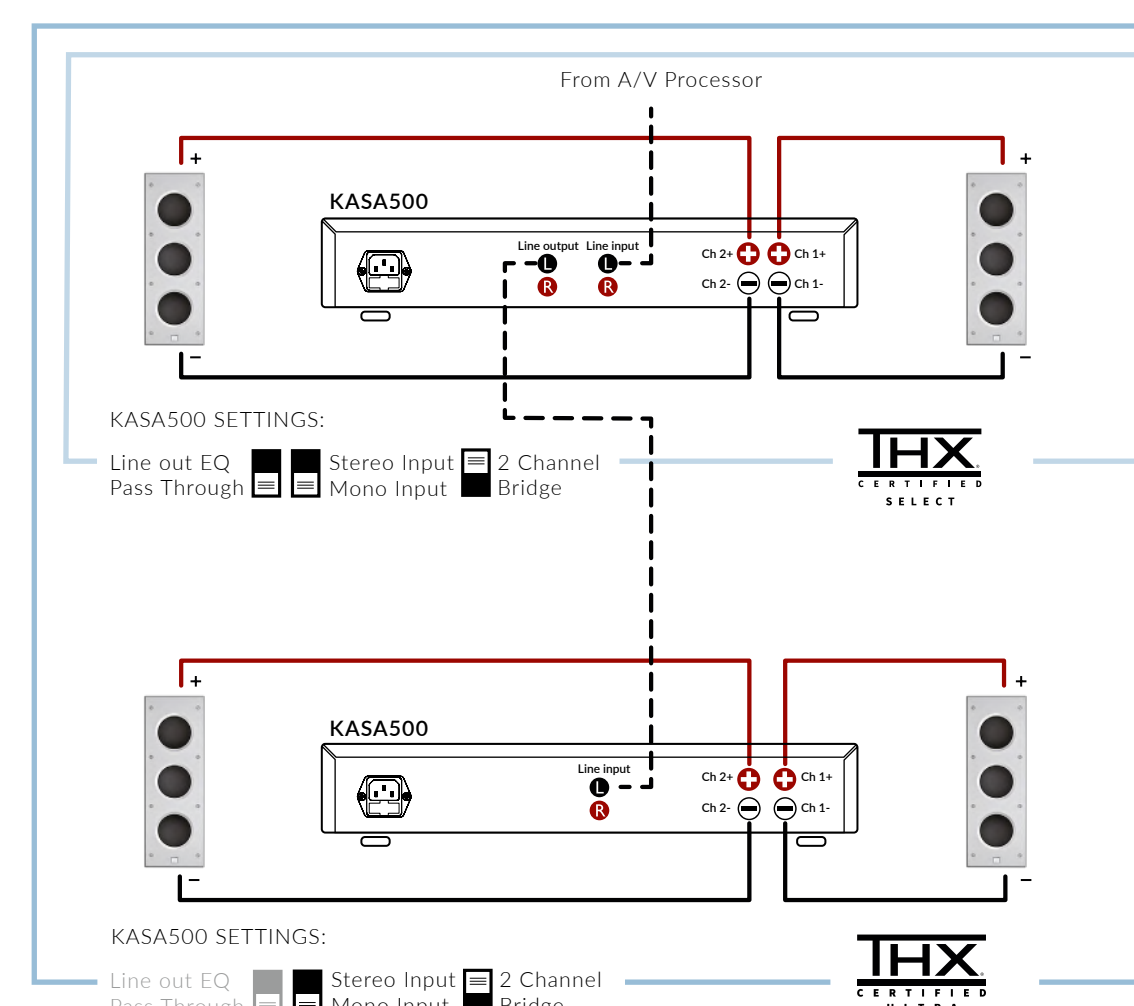

C1200Q5b-THX - THX CERTIFIED SELECT/ ULTRA

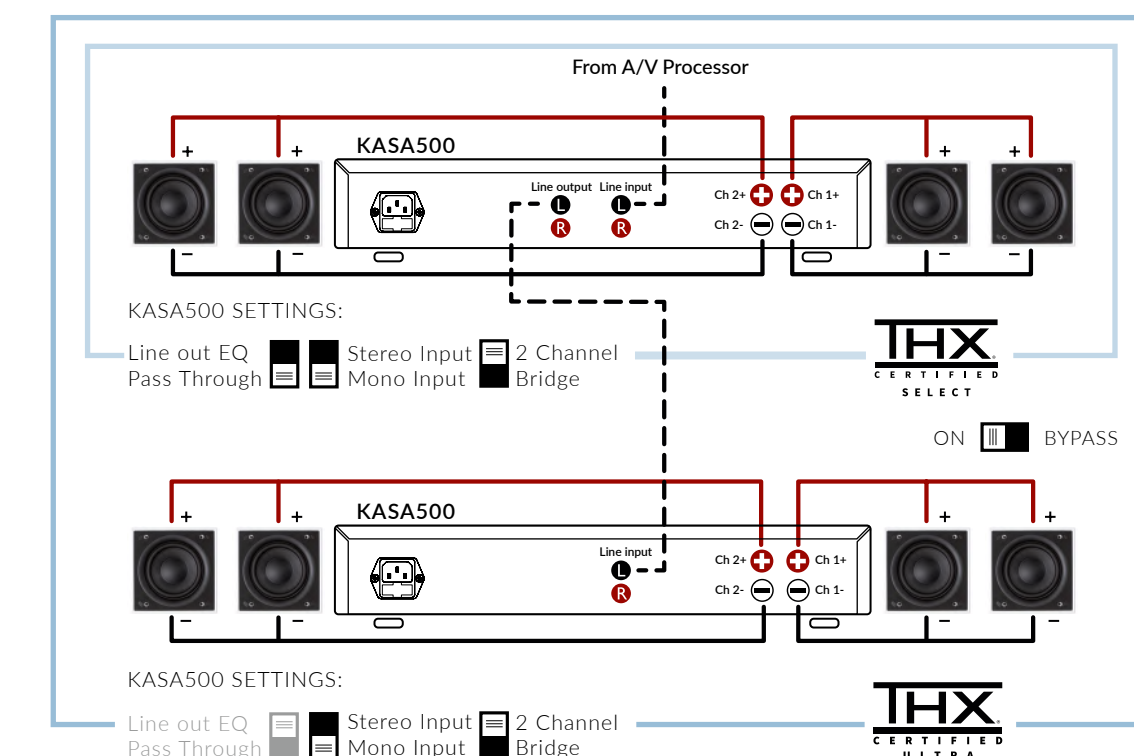

C1250Q5b-THX - THX CERTIFIED SELECT/ ULTRA

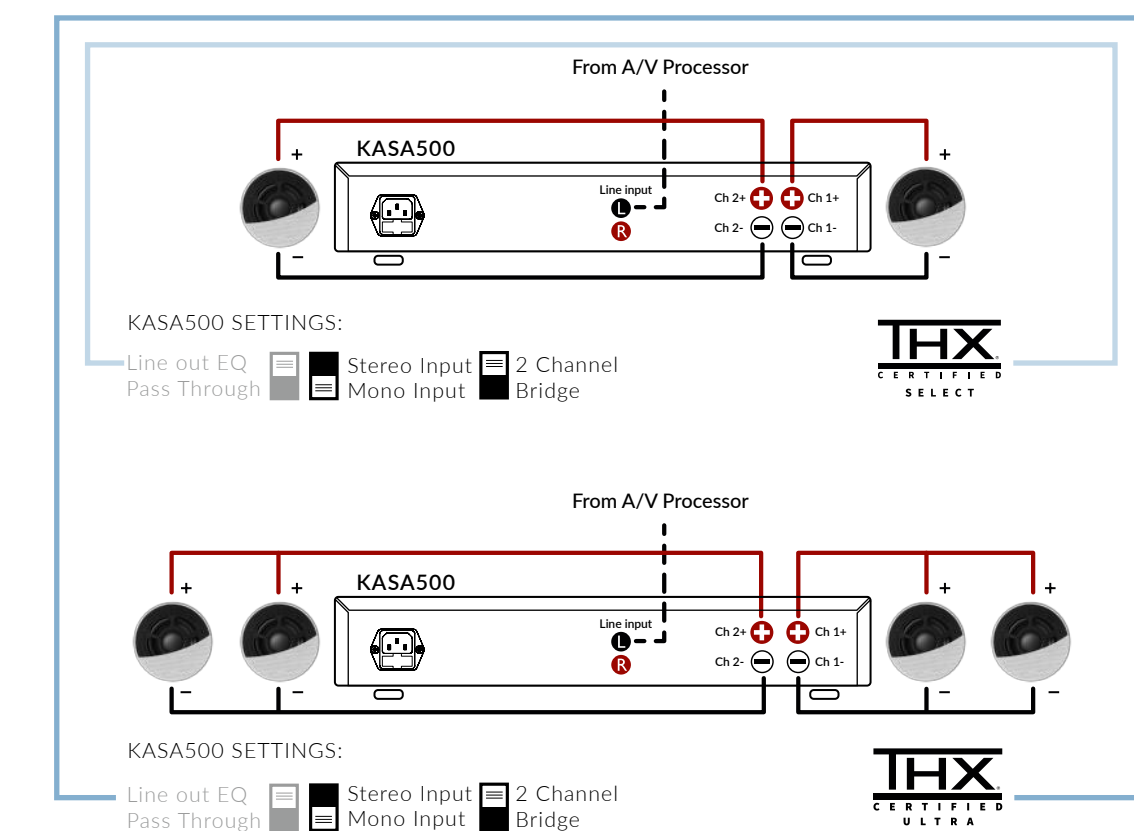

RECOMMENDED HOME THEATRE SPEAKER PLACEMENT





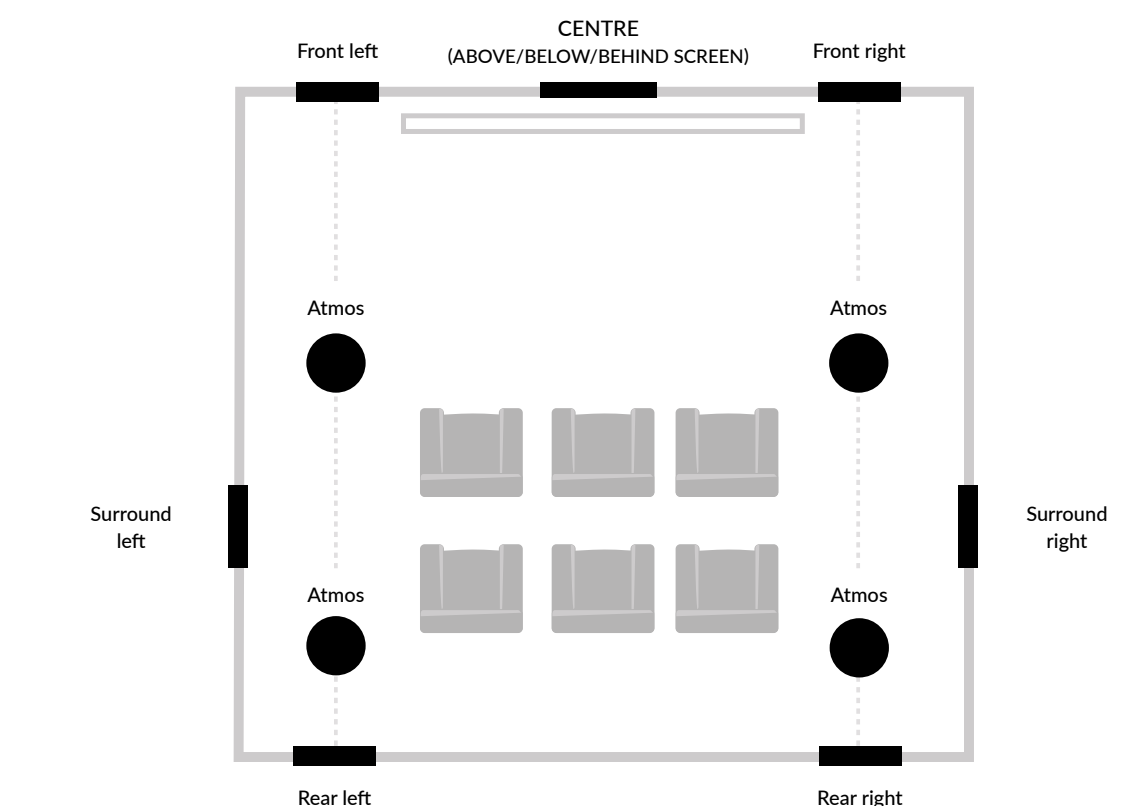



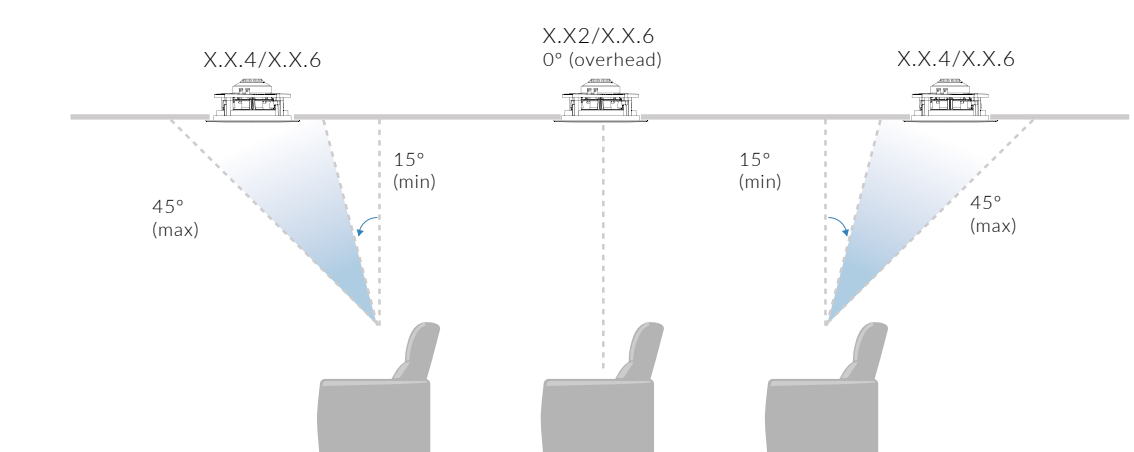







Due to the impressive off-axis response of Uni-Q, KEF recommends slightly different speaker placement for home theatre, designed to cover the whole listening area rather than cater for one single position (or provide subpar sound for all positions).



Front speakers should be positioned as wide as the seating area (with clearance from the side walls). The rear, as well as any Atmos channel speakers, should be positioned in line with the front speakers. Surround speakers should be positioned in line ear, or just behind the Main Listening Position. Both Surround and Rear speakers should be positioned above ear height to assist in diffusing ambient sounds throughout the room.



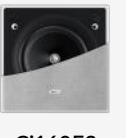



For Dolby Atmos, it is important for the overhead speakers to be positioned correctly, so that they work with the other speakers to faithfully deliver the sound effects. KEF recommends the following placement, measured from the side profile of the Main Listening Position, and still in line with the Front speakers. Note the configurations for the number of overhead speakers being used. Measure directly overhead from the middle of the listening area, front Atmos speakers from the front row, and rear Atmos speakers from the rear row.



	Tall Rectangle			Rectangle		Square				Round							
Woofer	5 x 160mm (5 x 6.5in.)	3 x 160mm (3 x 6.5in.)	4 x 100mm (4 x 4in.)	200mm (8in.)	160mm (6.5in.)	200mm (8in.)	160mm (6.5in.) T Series 115mm (4.5in.)	130mm (5.25in.)	100mm (4in.)	250mm (10in.)	200mm (8in.)	160 mm (6.5in.) T Series 115mm (4.5in.)	130mm (5.25in.)	75mm (3in.)			
Cut-out	1052 x 209mm (41.42 x 8.23in.)	660 x 209mm (25.98 x 8.23in.)	476 x 114mm (18.74 x 4.49in.)	334 x 238mm (13.15 x 9.37in.)	274 x 194mm (10.79 x 7.64in.)	238 x 238mm (9.37 x 9.37in.)	194 x 194mm (7.64 x 7.64in.)	158 x 158mm (6.22 x 6.22in.)	112 x 112mm (4.41 x 4.41in.)	Ø 300mm (11.81in.)	Ø240mm (9.45in.)	Ø196mm (Ø7.71 in.)	Ø158mm (Ø6.22in.)	Ø118mm (Ø4.65in.)			
Ci-Reference Extreme Home Theatre	 Ci160REFM-THX	 Ci3160REFM-THX															
Ci-R Series Extreme Home Theatre	 Ci5160RLM-THX	 Ci3160RLM-THX	 Ci3160RLb-THX *KASA500 required*			 Ci200RS-THX				 Ci250RRM-THX	 Ci250RRb-THX *KASA500 required*	 Ci200RR-THX	 Ci160RR-THX				
Ci-Q Series			 Ci4100QL-THX	 Ci200QL	 Ci160QL	 Ci200QS	 Ci200Qsb-THX *KASA500 recommended*	 Ci160QS	 Ci130QS	 Ci130QSII	 Ci100QS		 Ci200QR	 Ci160QR	 Ci130QR	 Ci130QRII	 Ci100.2QR
Ci-C Series					 Ci160.2CL			 Ci160.CSDS	 Ci160.2CS	 Ci130.2CS		 Ci200.2CR	 Ci160.CR4s	 Ci160.2CR	 Ci130.2CR		
Ci-E Series								 Ci160ES				 Ci200ER	 Ci160ER	 Ci130ER			
Ci-T Series								 Ci160TS				 Ci200TRb *KASA500 recommended*	 Ci160TR				
Rough-in Frame	RIF5160L	RIF3160L	RIF4100L	RIF200L	RIF160L	RIF200S	RIF160S	RIF130S	RIF100S	RIF250R	RIF200R	RIF160R	RIF130R	RIF100R			
Rear Enclosure	N/A	N/A	N/A	RNC200L	RNC160L	RNC200S Excluding Ci200RS-THX & Ci200Qsb-THX	RNC160S	RNC130S	RNC100S	N/A	RNC200R Excluding Ci200RR-THX	RNC160R	RNC130R	RNC100R			

OUTDOOR		
Woofer	160 mm (6.5 in.)	130 mm (5.25 in.)
Dimensions (H x W x D)	300 x 226 x 263.5 mm (11.8 x 9 x 10.37 in.)	262 x 197 x 235 mm (10.3 x 7.75 x 9.25 in.)
Finish	White/Black	White/Black
VENTURA	 Ventura 6	 Ventura 5

AMPLIFIERS AND ACCESSORIES		
AMPLIFICATION		
KASA500	Stereo to mono adaptor. Allows any KEF Ci product to play two channels (stereo) from a single speaker or equipment.	
ACCESSORIES	 Steel Rough-in Frames (See table for product code)	 Steel Rear Enclosures (See table for product code)
	 CITR-SM	

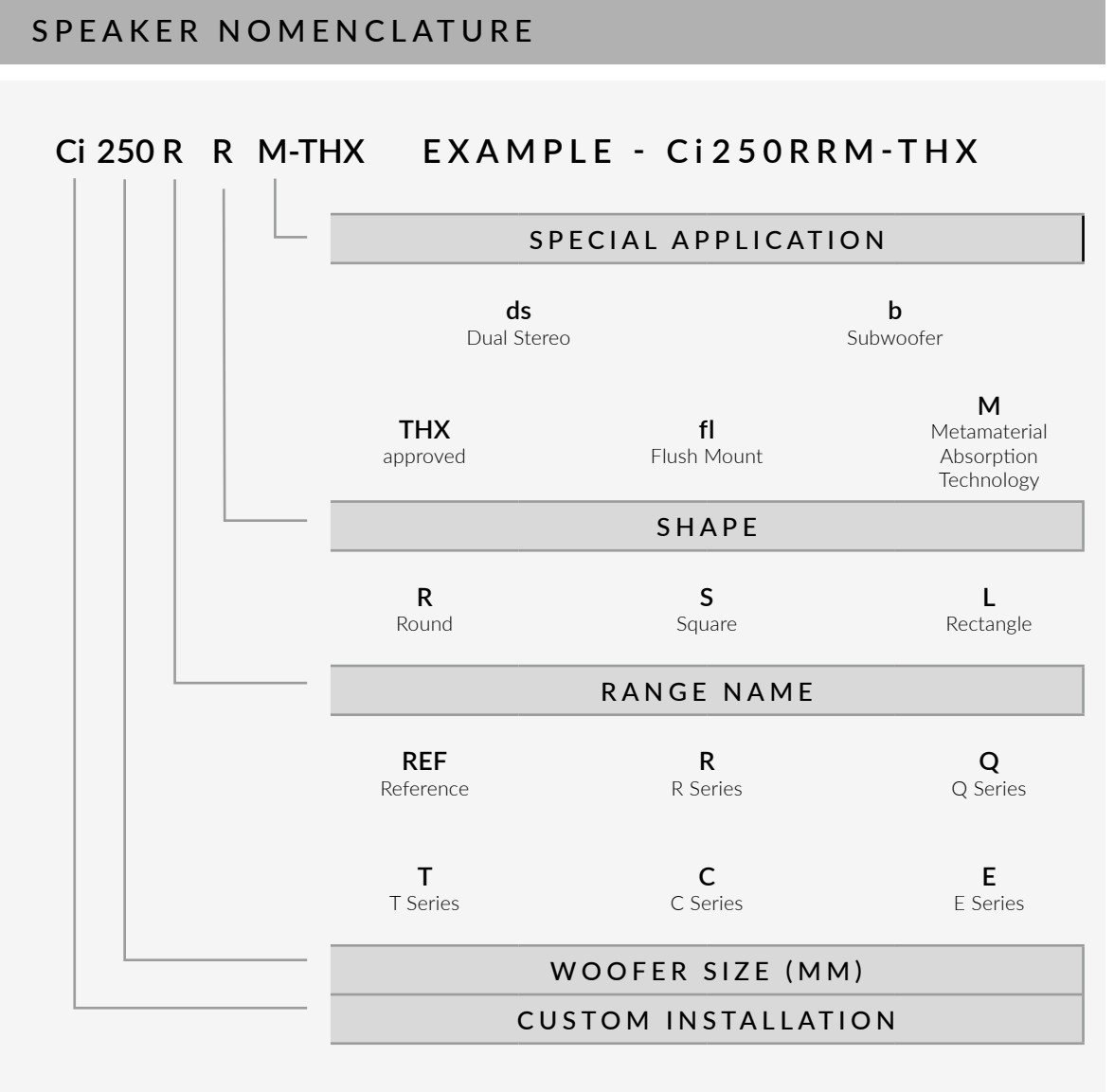

FEATURES

UNI-Q®

Uni-Q technology is the building block of KEF's signature sound. Uni-Q technology places the tweeter precisely at the acoustic centre of the bass/midrange cone, so both act together as a single point source to disperse sound evenly throughout the room. The result is the elimination of the limited 'sweet spot', allowing everybody sitting at different spots in the room to experience and enjoy the same natural, detailed sound.



CAVITY RADIATION CONTROL (CRC)

Cavity Radiation Control is a unique open-back midrange with acoustically absorptive foam design that eliminates both midrange dips and significant levels of distortion that are typically found in other coaxial three-way designs. CRC is critical to delivering a full, detailed and engaging performance, unprecedented in this format.



WEATHERPROOF

On the patio, by the pool, or on a yacht, the KEF Ventura Series outdoor speakers let customers enjoy music without compromise. Engineered to IP65 standards, these rugged, hard-wearing speakers can withstand even the most extreme weather conditions. All KEF round and square architectural models can also be used outside when installed under protected areas of the home, thanks to their IP64 certification and UV treated plastics.



EXTREMELY LOW PROFILE

KEF's incredible Ci-T Series is designed for delivering the highest quality sound when mounting depth is at an absolute premium. Even with a mounting depth of only 36mm, the Ci-T Series speakers still deliver exceptional KEF sound quality.



DUAL STEREO

For areas with space for only one speaker, KEF's Ci Series Dual Stereo model plays left and right channels from a single unit containing twin tweeters and a dual voice coil woofer.



METAMATERIAL ABSORPTION TECHNOLOGY (MAT™)

A truly revolutionary tool in the KEF acoustic armoury, MAT™ is a highly complex maze-like structure that absorbs 99% of unwanted sound from the rear of the tweeter, eliminating the resulting distortion and providing purer, more natural sound.



THX® CERTIFIED

KEF Extreme Home Theatre products are certified to various THX® levels - Select, Ultra and the awe-inspiring Dominus designations. Any system crafted from these loudspeakers delivers KEF's own jaw-dropping acoustic capabilities, with all the drama and emotional intensity of true theatre sound quality.



ULTRA-THIN BEZEL

Designed to sit tight to the wall or ceiling with no visible gap, KEF architectural speakers disappear for an incredibly discreet installation. The ultra-thin visible rim around the speaker casts virtually no shadow, while the bayonet style construction ensures a tight fit and seal, even when installed on an uneven surface.



FLUSH MOUNT

KEF's Flush Mount range blends premium sound with premium aesthetics. Sitting completely level with the wall or ceiling with no bezel makes these loudspeakers both easy to install and satisfyingly frameless when in place. In fact, the only hint that a KEF speaker is present is the natural, room-filling sound.



SOUNDLIGHT

As discreet as LED downlights, KEF's tiny Soundlight gives you big speaker performance with outstanding sound coverage, thanks to Uni-Q's exceptionally wide dispersion.



*KEF Ci subwoofer requires the KASA500 subwoofer amplifier. ** THX® Certified Ultra requires 4 x Ci3160RLb-THX or 4 pairs x Ci200Qsb-THX used with 2 x KASA500. *** THX® Certified Select requires 2 x Ci3160RLb-THX or 2 pairs x Ci200Qsb-THX used with 1 x KASA500. † Not all accessories and finishes are available in all markets, contact your local dealer for specific range details. THX and the THX Logo are the property of THX, LLC, registered in the U.S. and other countries. KEF reserves the right, in line with continuing research and development, to amend or change specifications. ES0E.