



Aegis ZS2

Gaming PC

User Guide



If you have any further questions regarding your new computer, please do not hesitate to contact us either through the online customer service site <https://us.msi.com/support> or by contacting our customer support at **1-626-271-1004**, Monday to Friday from 9:00 a.m. to 6:00 p.m. Pacific Standard Time. You can also contact technical support by calling **1-888-447-6564**, Monday to Friday open 24 hours (Weekend and Public Holiday closed). We will reply to you as soon as possible.

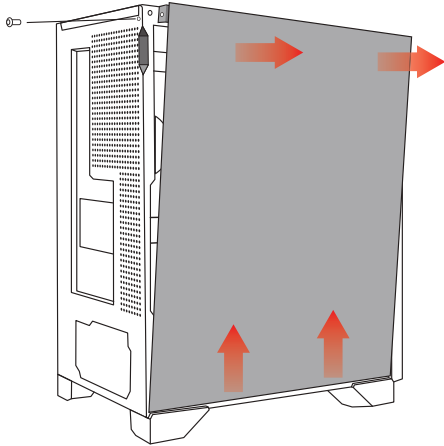

Step 1 REMOVE THE TEMPERED GLASS SIDE PANEL

Unscrew the captive screw on the rear side of the panel, and gently pull on the glass panel by using the divot handle by the screw. Once the glass panel is ajar, lift and remove the panel. Place the panel in a safe area.

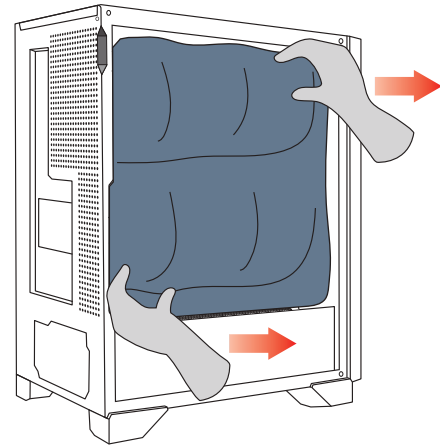

Step 2 REMOVE THE FOAM PACKAGING

Carefully pull the foam packaging out the system. It should come out easily without having to apply any force.

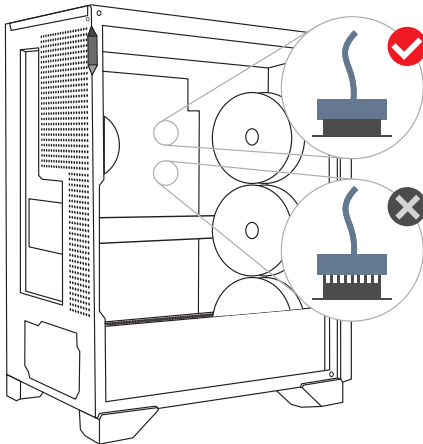

Step 3 INSPECT YOUR PC

Make sure all components and cables are seated firmly. Now, you can replace the tempered glass side panel and secure with thumbscrews.

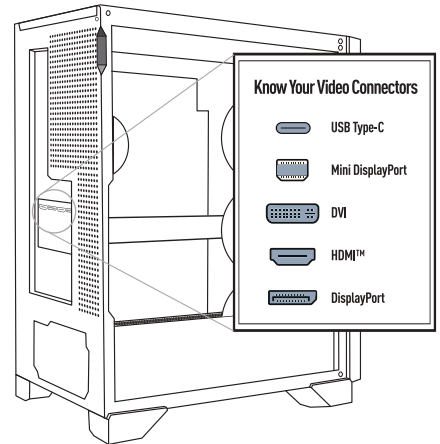

Step 4 CONNECT YOUR MONITOR

Connect your monitor to either Displayport or HDMI™ ports on the GRAPHICS CARD. Avoid using any video ports that may be located higher up on the motherboard by the USB ports.

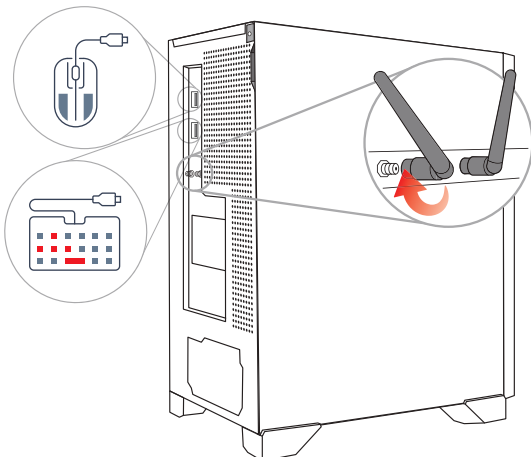

Step 5 CONNECT WIFI ANTENNAE, KEYBOARD & MOUSE

Screw the Wi-Fi Antennae to the gold contact points on the rear of the case. Plug the mouse and the keyboard into any of the USB ports.

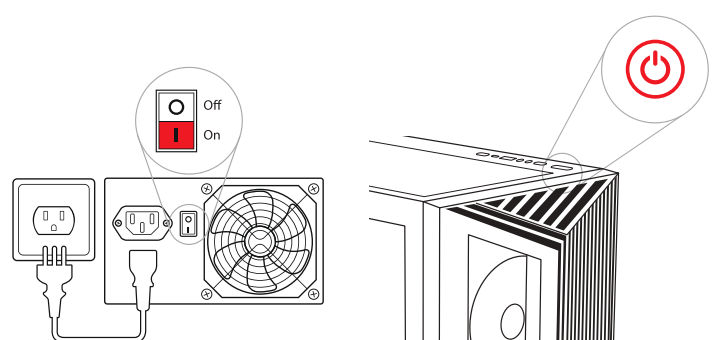

Step 6 POWER ON YOUR DESKTOP

Plug the power cable into the power cable socket and plug the other end of the power cable into a power outlet. Turn the power supply switch on by having the "I" symbol on the switch pressed down. Press the power button.

Contents

| | |
|---------------------------------------------------------------|----|
| Quick Start..... | 3 |
| Specifications..... | 16 |
| Special Features | 20 |
| Package Contents | 21 |
| Back Panel Connectors | 22 |
| LAN Port LED Status Table | 23 |
| Audio Jacks Connection | 23 |
| Installing Antennas..... | 25 |
| Overview of Components | 26 |
| CPU Socket..... | 27 |
| DIMM Slots..... | 28 |
| PCI_E1~4: PCIe Expansion Slots..... | 29 |
| M2_1~2: M.2 Slots (Key M) | 30 |
| SATA_1~2, SATA_A1~A4: SATA 6Gb/s Connectors..... | 33 |
| JAUD1: Front Audio Connector | 34 |
| JFP1, JFP2: Front Panel Connectors..... | 34 |
| CPU_PWR1~2, ATX_PWR1: Power Connectors | 35 |
| JCI1: Chassis Intrusion Connector..... | 36 |
| JUSB1: USB 3.2 Gen 2 10Gbps Type-C front panel Connector..... | 37 |
| JUSB2: USB 3.2 Gen 1 Connector | 37 |
| JUSB3~4: USB 2.0 Connectors..... | 38 |
| JTPM1: TPM Module Connector..... | 38 |
| CPU_FAN1, PUMP_FAN1, SYS_FAN1~4: Fan Connectors..... | 39 |
| JBAT1: Clear CMOS (Reset BIOS) Jumper..... | 40 |
| JRGB1~2: RGB LED connectors..... | 41 |
| JARGB_V2_1~2: A-RAINBOW V2 (ARGB Gen2) LED connectors..... | 42 |
| JOCFS1: Safe Boot Jumper | 44 |
| JDASH1 : Tuning Controller connector..... | 44 |
| Onboard LEDs..... | 45 |
| EZ Debug LED..... | 45 |
| LED_SW1: EZ LED Control | 45 |
| Installing OS, Drivers & MSI Center..... | 46 |

| | |
|-----------------------------------------------------------|----|
| Installing Drivers with MSI Driver Utility Installer..... | 47 |
| MSI Center..... | 49 |
| UEFI BIOS..... | 50 |
| BIOS Setup..... | 51 |
| Resetting BIOS..... | 52 |
| Updating BIOS..... | 52 |

Quick Start

Thank you for purchasing a new motherboard from MSI®. This Quick Start section provides demonstration diagrams about how to install your computer. Some of the installations also provide video demonstrations. Please link to the URL to watch it with the web browser on your phone or tablet. You may have even link to the URL by scanning the QR code.

Preparing Tools and Components

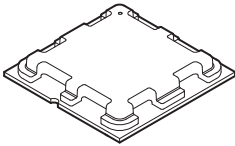

AMD® AM5 CPU

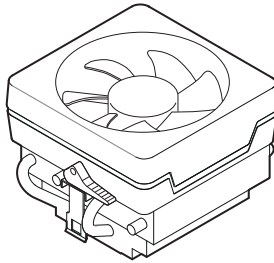

AM5 CPU Fan

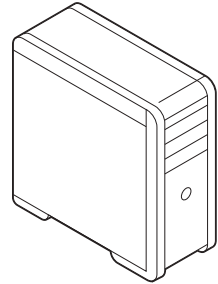

Chassis

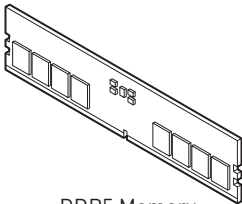

DDR5 Memory

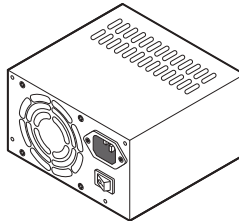

Power Supply Unit

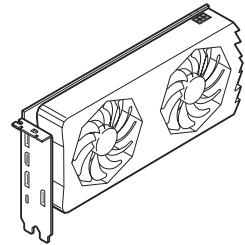

Graphics Card

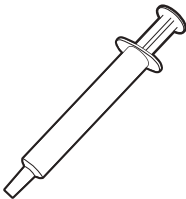

Thermal Paste

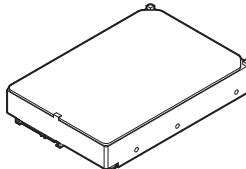

SATA Hard Disk Drive

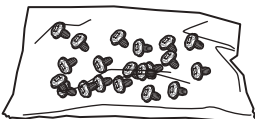

A Package of Screws

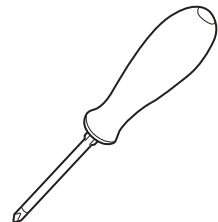

Phillips Screwdriver

Safety Information

- The components included in this package are prone to damage from electrostatic discharge (ESD). Please adhere to the following instructions to ensure successful computer assembly.
- Ensure that all components are securely connected. Loose connections may cause the computer to not recognize a component or fail to start.
- Hold the motherboard by the edges to avoid touching sensitive components.
- It is recommended to wear an electrostatic discharge (ESD) wrist strap when handling the motherboard to prevent electrostatic damage. If an ESD wrist strap is not available, discharge yourself of static electricity by touching another metal object before handling the motherboard.
- Store the motherboard in an electrostatic shielding container or on an anti-static pad whenever the motherboard is not installed.
- Before turning on the computer, ensure that there are no loose screws or metal components on the motherboard or anywhere within the computer case.
- Do not boot the computer before installation is completed. This could cause permanent damage to the components as well as injury to the user.
- If you need help during any installation step, please consult a certified computer technician.
- Always turn off the power supply and unplug the power cord from the power outlet before installing or removing any computer component.
- Keep this user guide for future reference.
- Keep this motherboard away from humidity.
- Make sure that your electrical outlet provides the same voltage as is indicated on the PSU, before connecting the PSU to the electrical outlet.
- Place the power cord such a way that people can not step on it. Do not place anything over the power cord.
- All cautions and warnings on the motherboard should be noted.
- If any of the following situations arises, get the motherboard checked by service personnel:
 - Liquid has penetrated into the computer.
 - The motherboard has been exposed to moisture.
 - The motherboard does not work well or you can not get it work according to user guide.
 - The motherboard has been dropped and damaged.
 - The motherboard has obvious sign of breakage.
- Do not leave this motherboard in an environment above 60°C (140°F), it may damage the motherboard.

Case stand-off notification

To prevent damage to the motherboard, any unnecessary mounting stand-off between the motherboard circuits and the computer case is prohibited. The Case standoff keep out zone signs will be marked on the backside of motherboard (as shown below) to serve as a warning to user.

Avoid collision notification

Protective paint is printed around each screw hole to prevent parts from being scratched.

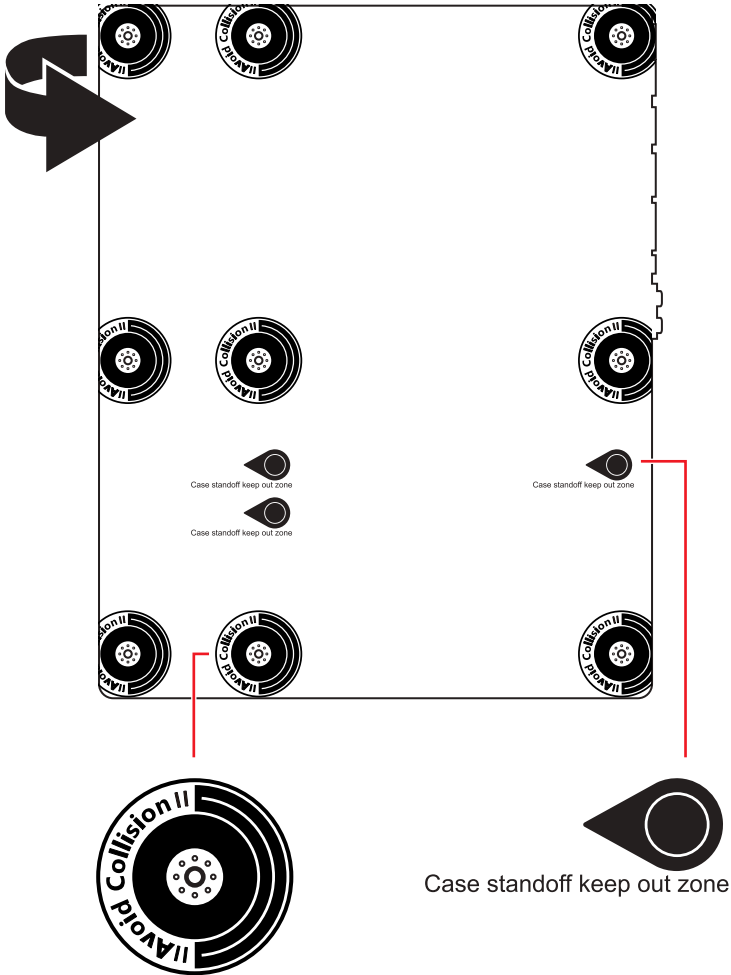

Installing a Processor



• <https://youtu.be/ctlgIYiGtWY>

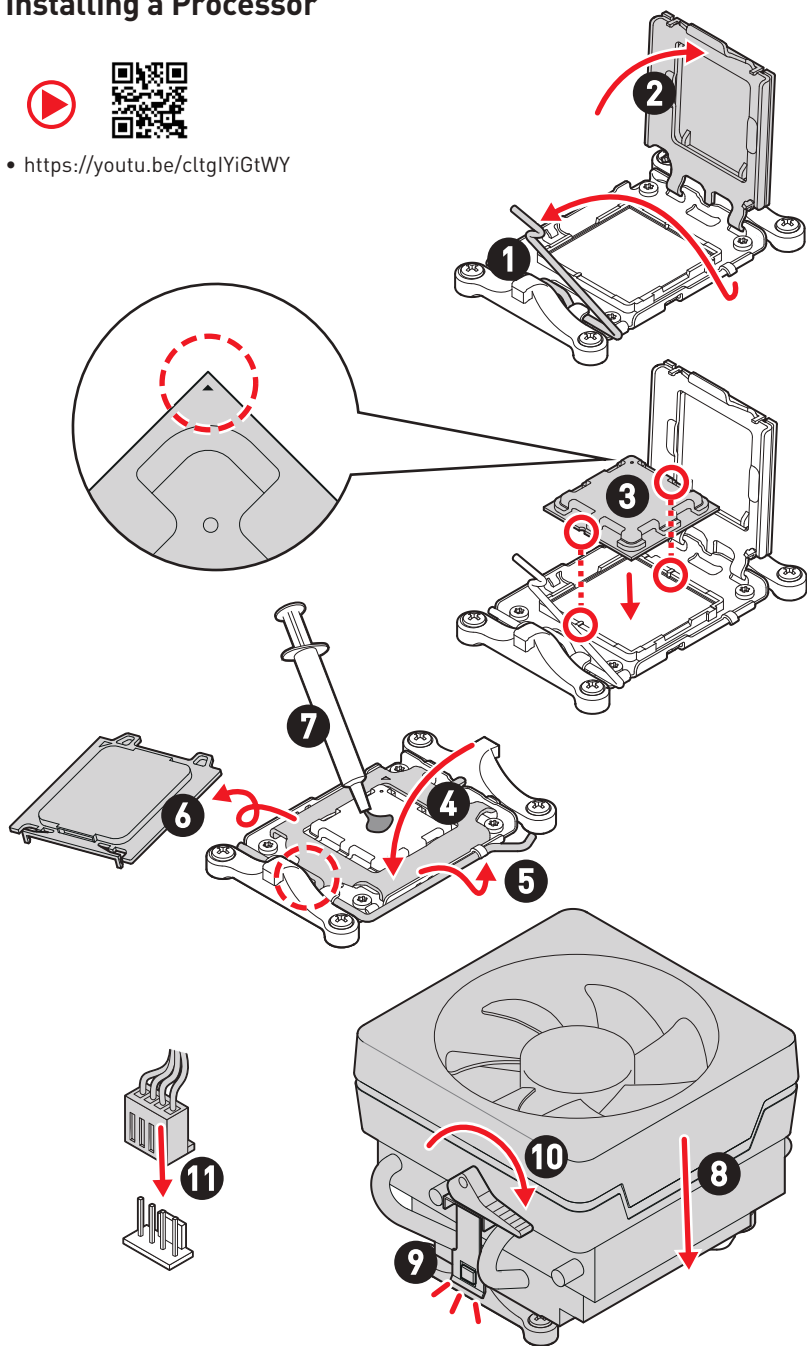

 **Important**

If you are installing the screw-type CPU heatsink, please follow the figure below to remove the retention module first and then install the heatsink.

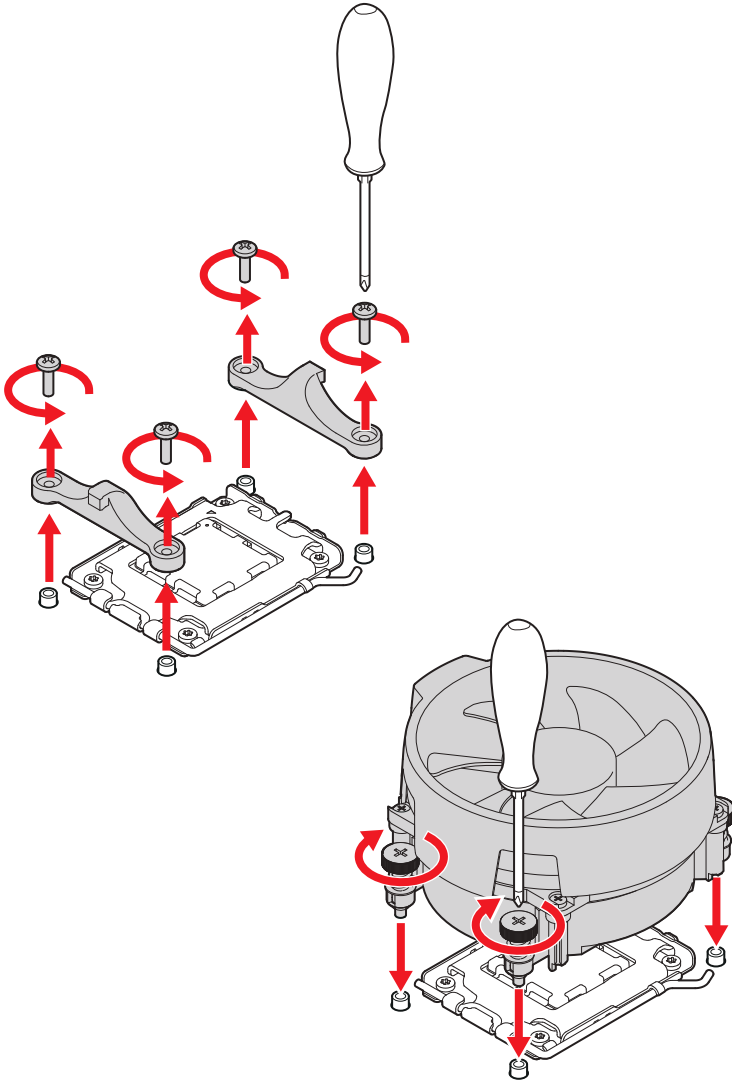

Installing DDR5 memory



- <https://youtu.be/XiNmKDNZcZk>

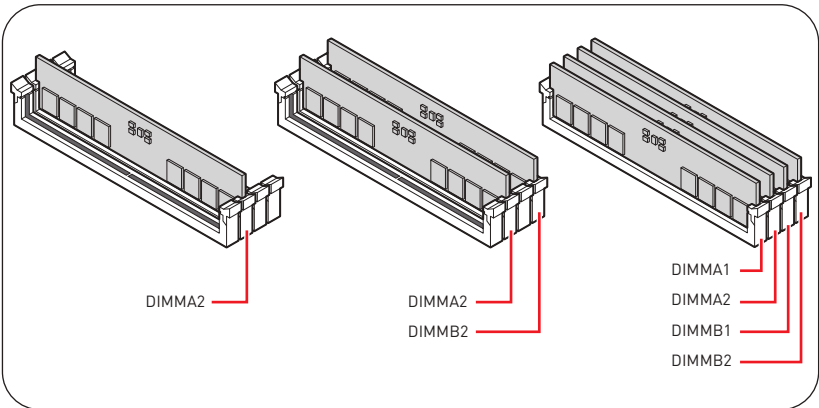
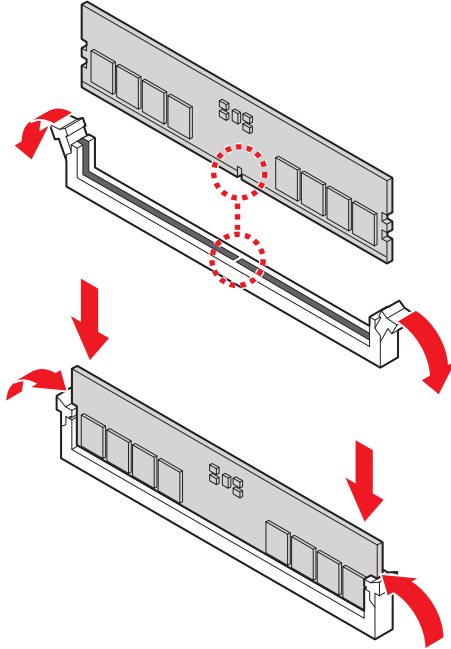

Connecting the Front Panel Header



- <http://youtu.be/DPELIdVNZUI>

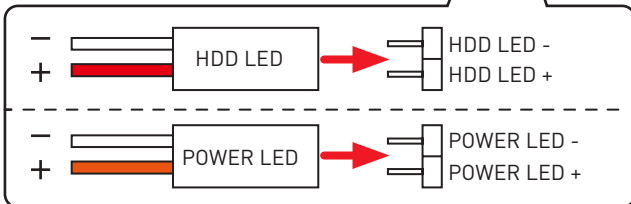
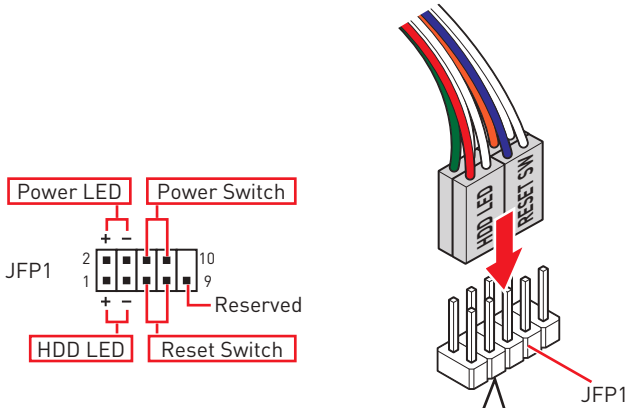
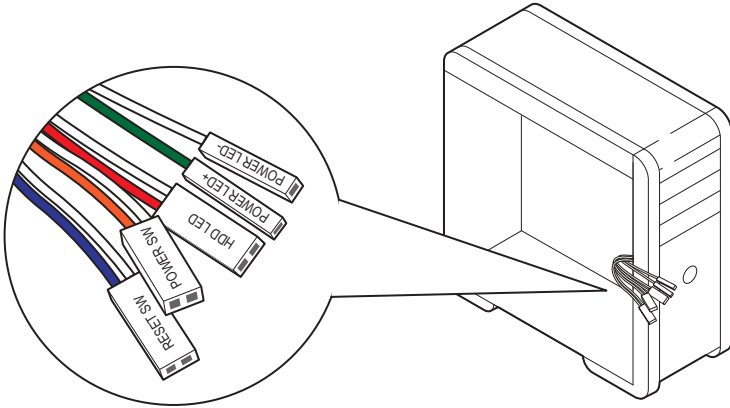

Installing the Motherboard



• <https://youtu.be/wWI6Qt51Wnc>

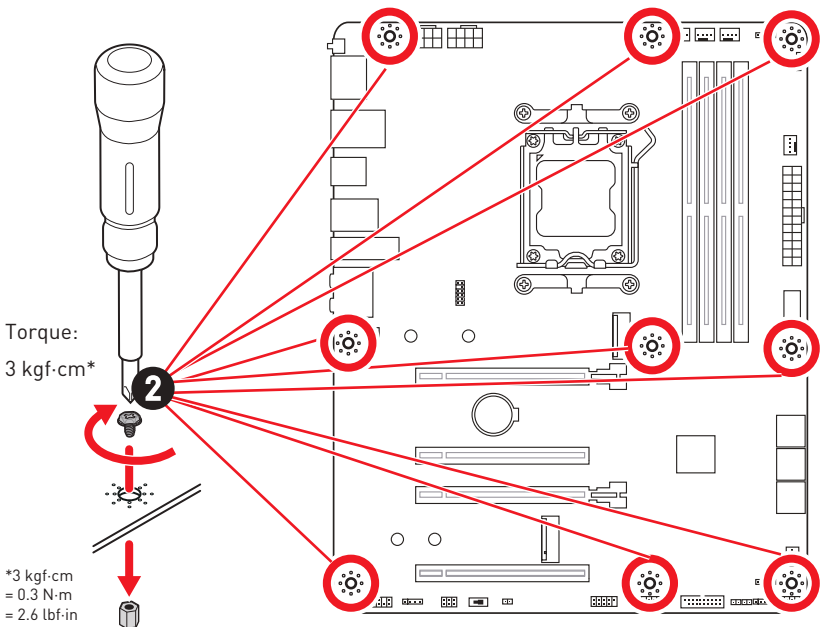
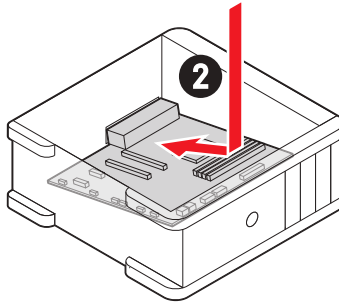
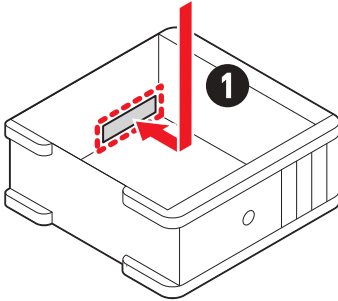

Connecting the Power Connectors



- http://youtu.be/gkDYyR_8314

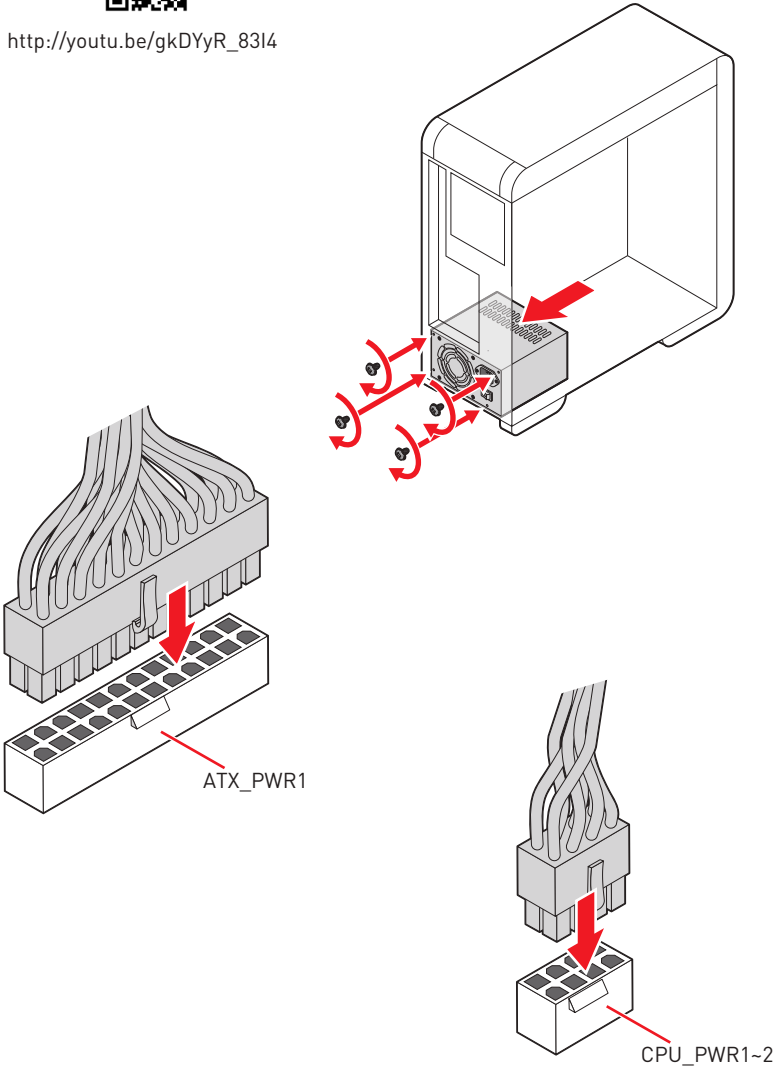

Installing SATA Drives



• <http://youtu.be/RZsMpqxythc>

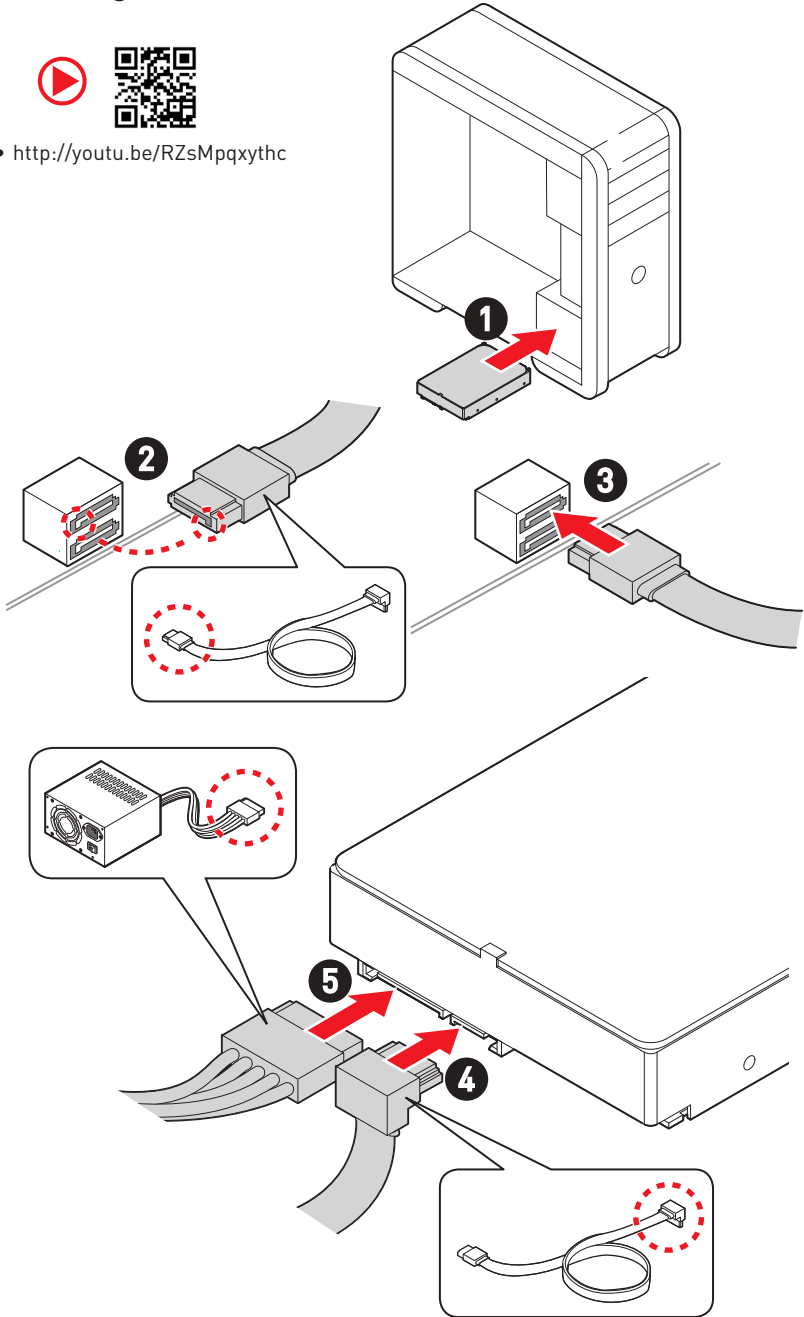

Installing a Graphics Card



• http://youtu.be/mG0GZpr9w_A

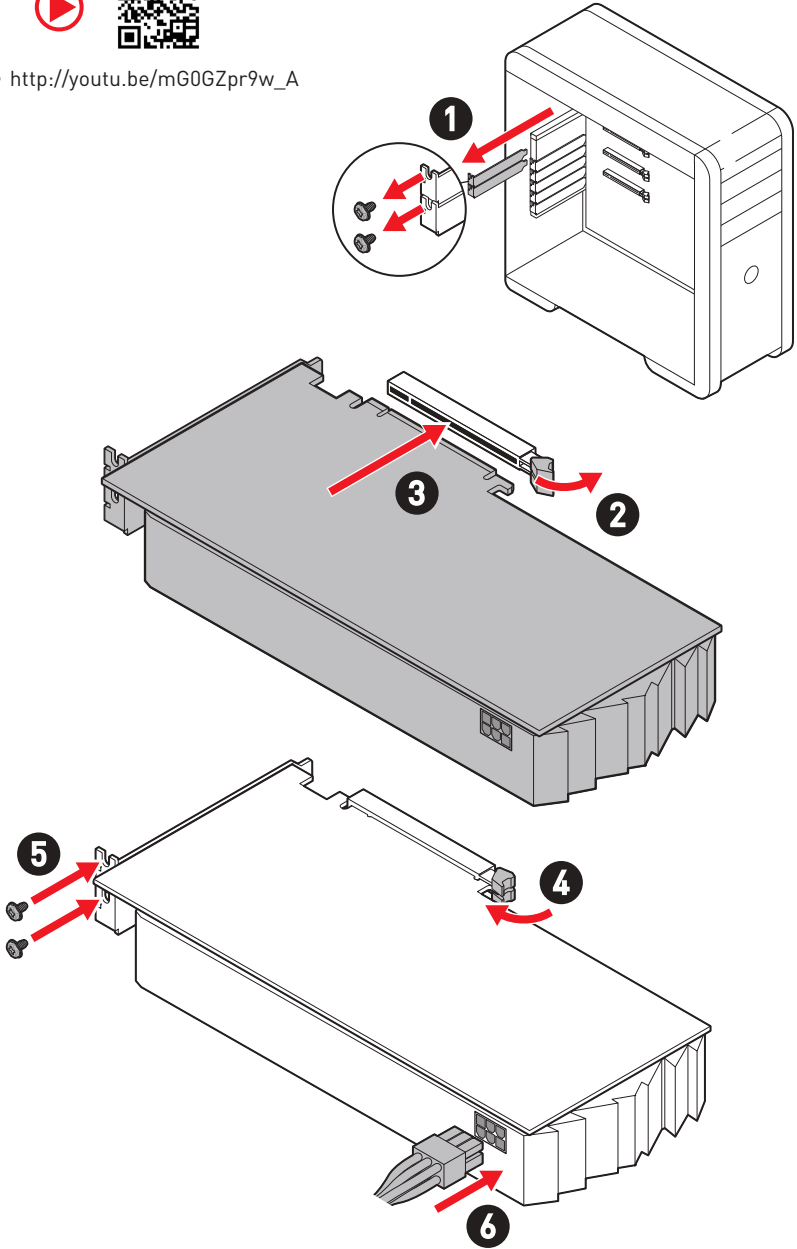

Connecting Peripheral Devices

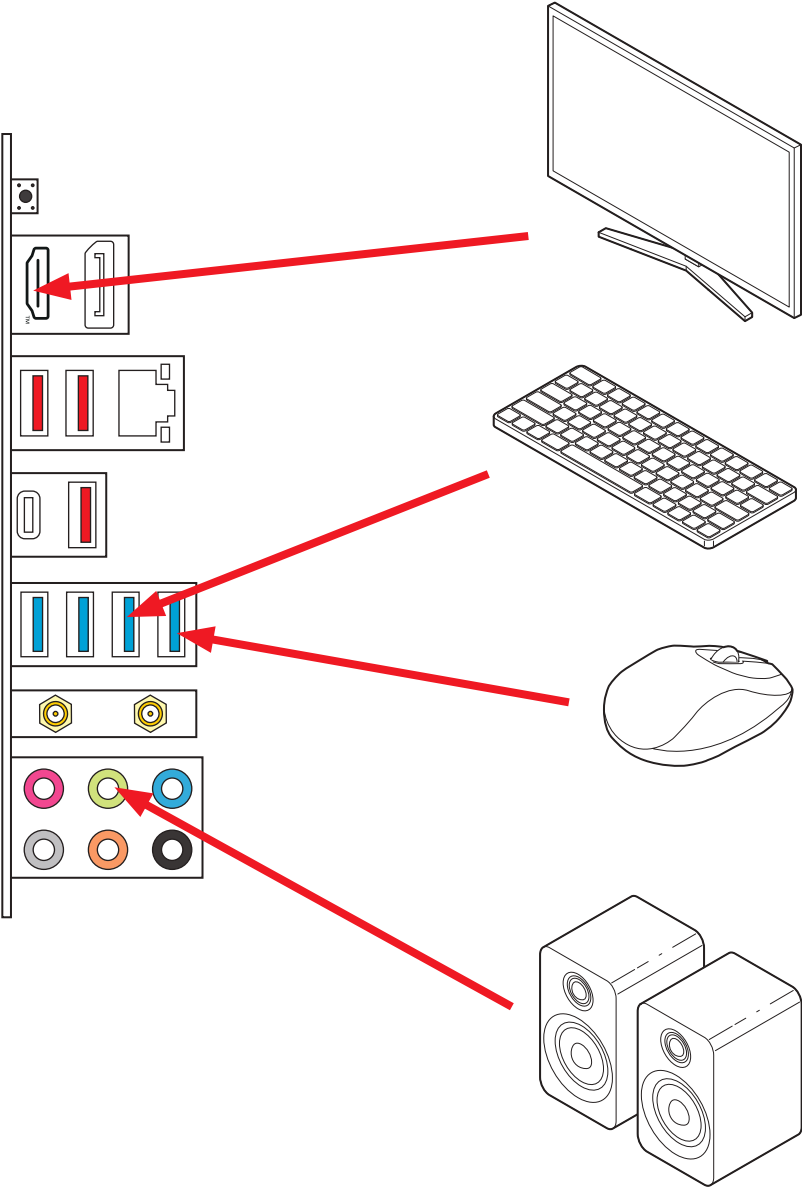

Power On

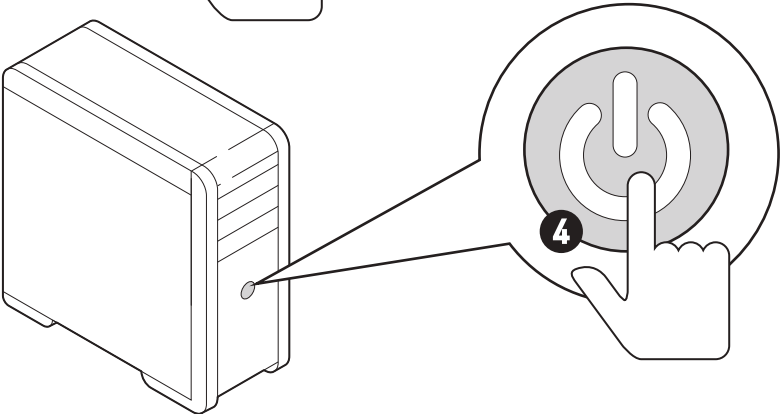
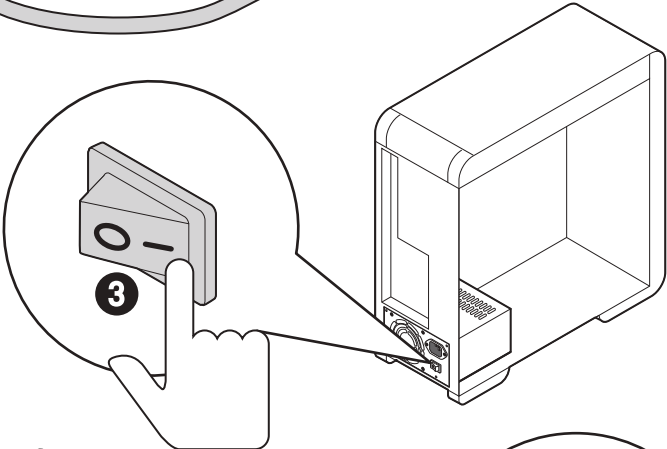
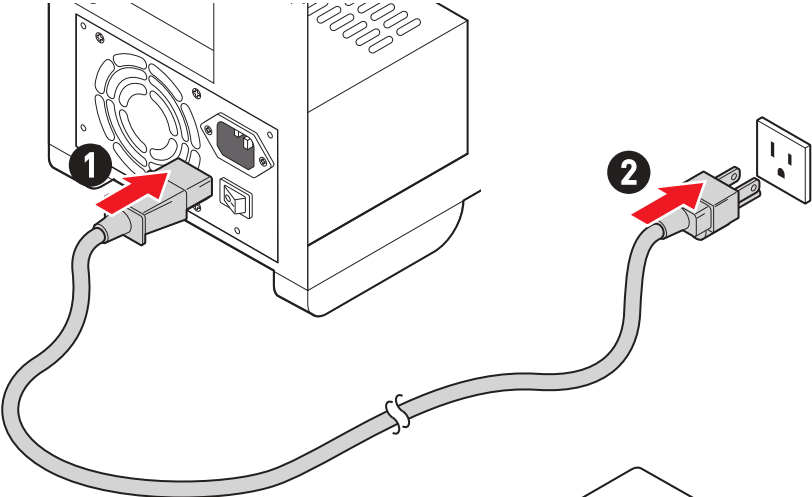

Specifications

| | |
|------------------------|------------------------------------------------------------------------------------------------------------------------------------------------------------------------------------------------------------------------------------------------------------------------------------------------------------------------------------------------------------------------------------------------------------------------------------------------------------------------------------------------------------------------------------------------------------------------------------------------------------------------------------------------------------------------------------------------------------------------------------------------------------------------------------------------------------------------------------------------------------------------------------|
| CPU | <ul style="list-style-type: none"> • Supports AMD Ryzen™ 8000 and 7000 Series Desktop Processors* • Processor socket AM5 <p>* Please go to www.msi.com to get the newest support status as new processors are released.</p> |
| Chipset | AMD B650 Chipset |
| Memory | <ul style="list-style-type: none"> • 4x DDR5 memory slots, supporting up to 192GB* • Supports 1R 4800 MT/s by JEDEC • Max. overclocking frequency: <ul style="list-style-type: none"> • 1DPC 1R Max. speed up to 6000+ MT/s • 1DPC 2R Max. speed up to 6000+ MT/s • 2DPC 1R Max. speed up to 6000+ MT/s • 2DPC 2R Max. speed up to 6000+ MT/s • Supports Dual-Channel mode • Supports non-ECC, un-buffered memory • Supports AMD EXPO <p>* Please refer to www.msi.com for more information on compatible memory.</p> |
| Expansion Slots | <ul style="list-style-type: none"> • 4x PCIe x16 slots <ul style="list-style-type: none"> • PCI_E1 slot (From CPU) <ul style="list-style-type: none"> • Supports up to PCIe 4.0 x16 (For Ryzen™ 7000 Series processors) • Supports up to PCIe 4.0 x8 (For Ryzen™ 7 8700G and Ryzen™ 5 8600G processors) • Supports up to PCIe 4.0 x4 (For Ryzen™ 5 8500G processor) • PCI_E2 (From B650 chipset) <ul style="list-style-type: none"> • Supports up to PCIe 3.0 x1 • PCI_E3 (From B650 chipset) <ul style="list-style-type: none"> • Supports up to PCIe 4.0 x4 • PCI_E4 (From B650 chipset) <ul style="list-style-type: none"> • Supports up to PCIe 3.0 x1 |
| Multi-GPU | <ul style="list-style-type: none"> • Supports AMD Multi-GPU |

Continued on next column

Continued from previous column

| | |
|-------------------------------|--------------------------------------------------------------------------------------------------------------------------------------------------------------------------------------------------------------------------------------------------------------------------------------------------------------------------------------------------------------------------------------------------------------------------------------------------------------------------------------------------------------------------------------------------------------------------------|
| Onboard Graphics | <ul style="list-style-type: none"> • 1x HDMI™ 2.1 port with HDR, supports a maximum resolution of 4K 60Hz*/ ** • 1x DisplayPort 1.4 supports a maximum resolution of 4K 60Hz*/ ** <p>* Available only on processors featuring integrated graphics. ** Graphics specifications may vary depending on the CPU installed.</p> |
| SATA Ports | <ul style="list-style-type: none"> • 6x SATA 6Gb/s ports • SATA_1~2 (From B650 chipset) • SATA_A1~A4 (From ASM1064) |
| M.2 SSD Slots | <ul style="list-style-type: none"> • 2x M.2 slots (Key M) • M2_1 slot (From CPU) <ul style="list-style-type: none"> • Supports up to PCIe 4.0 x4 • Supports 2280/ 22110 storage devices • M2_2* slot (From CPU) <ul style="list-style-type: none"> • Supports up to PCIe 4.0 x4 • Supports 2260/ 2280 storage devices <p>* The M2_2 slot will be unavailable when using Ryzen™ 5 8500G processor.</p> |
| RAID | <ul style="list-style-type: none"> • Supports RAID 0 and RAID 1 for SATA storage devices* • Supports RAID 0 and RAID 1 for M.2 NVMe storage devices <p>* SATA_A1~A4 do not support RAID function.</p> |
| Audio | <p>Realtek® ALC897 Codec</p> <ul style="list-style-type: none"> • 7.1-Channel High Definition Audio |
| LAN | <ul style="list-style-type: none"> • 1x Realtek® 8125BG 2.5Gbps LAN controller |
| Wi-Fi & Bluetooth® | <p>AMD Wi-Fi 6E</p> <ul style="list-style-type: none"> • The Wireless module is pre-installed in the M.2 (Key-E) slot • Supports MU-MIMO TX/RX • Supports 20MHz, 40MHz, 80MHz, 160MHz bandwidth in 2.4GHz/ 5GHz or 6GHz* bands • Supports 802.11 a/ b/ g/ n/ ac/ ax • Supports Bluetooth® 5.2** <p>* The usage of Wi-Fi 6GHz band relies on Windows 11 support and depends on every country's regulations. ** The Bluetooth version may be updated, please refer to the Wi-Fi chipset vendor's website for details.</p> |

Continued on next column

Continued from previous column

| | |
|--------------------------------|--------------------------------------------------------------------------------------------------------------------------------------------------------------------------------------------------------------------------------------------------------------------------------------------------------------------------------------------------------------------------------------------------------------------------------|
| Power Connectors | <ul style="list-style-type: none">• 1x 24-pin ATX main power connector• 2x 8-pin +12V power connectors |
| Internal USB Connectors | <ul style="list-style-type: none">• 1x USB 3.2 Gen 2 10Gbps Type-C front panel port (From B650 chipset)• 1x USB 3.2 Gen 1 5Gbps connector (From B650 chipset)<ul style="list-style-type: none">• Supports additional 2 USB 3.2 Gen 1 5Gbps ports• 2x USB 2.0 connectors (From B650 chipset)<ul style="list-style-type: none">• Supports additional 4 USB 2.0 ports |
| Fan Connectors | <ul style="list-style-type: none">• 1x 4-pin CPU fan connector• 1x 4-pin water-pump fan connector• 4x 4-pin system fan connectors |
| System Connectors | <ul style="list-style-type: none">• 1x Front panel audio connector• 2x System panel connectors• 1x Chassis Intrusion connector• 1x TPM module connector• 1x Tuning Controller connector |
| Jumpers | <ul style="list-style-type: none">• 1x Clear CMOS jumper• 1x OC safe boot jumper |
| LED Features | <ul style="list-style-type: none">• 1x EZ LED Control switch• 2x 4-pin RGB LED connectors• 2x 3-pin A-RAINBOW V2 (ARGB Gen2) LED connectors• 4x EZ Debug LED |
| Back Panel Connectors | <ul style="list-style-type: none">• 1x Flash BIOS button• 1x DisplayPort• 1x HDMI™ port• 1x 2.5 Gbps LAN (RJ45) port• 3x USB 3.2 Gen 2 10Gbps Type-A ports (From CPU)• 1x USB 3.2 Gen 2x2 20Gbps Type-C port (From B650 chipset)• 4x USB 3.2 Gen 1 5Gbps Type-A port (From Hub-1074)• 2x Wi-Fi antenna connectors• 6x audio jacks |

Continued on next column

Continued from previous column

| | |
|-------------------------|--------------------------------------------------------------------------------------------------------------------------------------------------------------------------------------------|
| I/O Controller | NUVOTON NCT6687-R Controller Chip |
| Hardware Monitor | <ul style="list-style-type: none">• CPU/ System/ Chipset temperature detection• CPU/ System/ Pump fan speed detection• CPU/ System/ Pump fan speed control |
| Form Factor | <ul style="list-style-type: none">• ATX Form Factor• 9.6 in. x 12.0 in. (244 mm x 305 mm) |
| BIOS Features | <ul style="list-style-type: none">• 1x 256 Mb flash• UEFI AMI BIOS• ACPI 6.4, SMBIOS 3.5• Multi-language |
| Software | <ul style="list-style-type: none">• Drivers• MSI Center• CPU-Z MSI GAMING• Norton 360 Deluxe• AIDA64 Extreme - MSI Edition |

Special Features

MSI Center

- Mystic Light
- Ambient Link
- User Scenario
- True Color
- Live Update
- Hardware Monitoring
- Super Charger
- Devices Speed Up
- Smart Image Finder
- MSI Companion
- System Diagnosis
- Smart Fan Control

Thermal Features

- K7 MOSFET thermal pad / Extra choke pad
- Fan headers (CPU + PUMP + SYSTEM)

Performance

- Core Boost
- VRM Power Design (12+2+1 (DRPS))
- Dual CPU Power
- Memory Boost
- Lightning Gen 4 PCI-E / M.2 Slot
- Front USB Type-C
- 2oz Copper thickened PCB

DIY Friendly

- PCI-E Steel Armor
- EZ M.2 Clips
- EZ DEBUG LED
- EZ LED Control
- Flash BIOS Button

Audio

- Audio Boost

RGB Support

- Mystic Light Extension (RGB)
- Mystic Light Extension (A-RAINBOW V2)
- Ambient Link Support

BIOS

- Click BIOS 5

Package Contents

Please check the contents of your motherboard package. It should contain:

Board

- 1x Motherboard

Documentation

- 1x Quick installation guide
- 1x European Union regulatory notice

Cables

- 1x SATA6Gb/s cable

Accessories

- 1x Wi-Fi antenna set
- 1x I/O Shielding
- 2x EZ M.2 clip packages (1 set/pack)



Important

If any of the above items are damaged or missing, please contact your retailer.

Back Panel Connectors

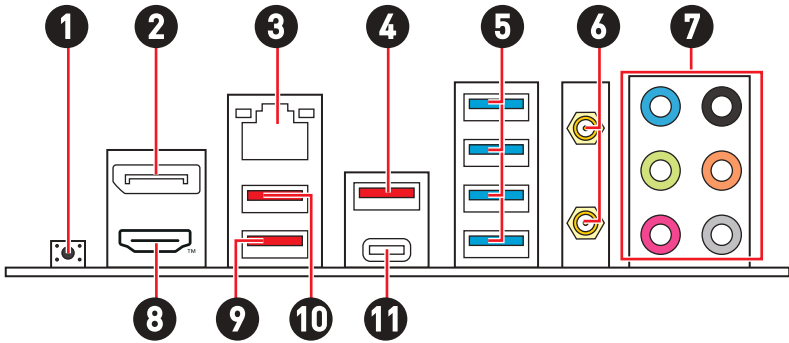

| Item | Description |
|------|-----------------------------------------------------------------------------------------------------|
| 1 | Flash BIOS button - Please refer to page 53 for details about updating BIOS with Flash BIOS button. |
| 2 | DisplayPort |
| 3 | 2.5 Gbps LAN jack |
| 4 | USB 3.2 Gen 2 10Gbps Type-A port (From CPU) |
| 5 | USB 3.2 Gen 1 5Gbps Type-A ports (From Hub-1074) |
| 6 | Wi-Fi antenna connectors |
| 7 | Audio jacks |
| 8 | HDMI™ port HDMI™ HIGH-DEFINITION MULTIMEDIA INTERFACE |
| 9 | USB 3.2 Gen 2 10Gbps Type-A port (From CPU) • Flash BIOS Port |
| 10 | USB 3.2 Gen 2 10Gbps Type-A port (From CPU)) |
| 11 | USB 3.2 Gen 2x2 20Gbps Type-C port (From B650 chipset) |

LAN Port LED Status Table

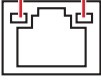
| Link/ Activity LED | |  | Speed LED | |
|--------------------|---------------|-----------------------------------------------------------------------------------|-----------|---------------|
| Status | Description | | Status | Speed |
| Off | No link | | Off | 10 Mbps |
| Yellow | Linked | | Green | 100~1000 Mbps |
| Blinking | Data activity | | Orange | 2.5 Gbps |

Audio Jacks Connection

Audio jacks to headphone and microphone diagram

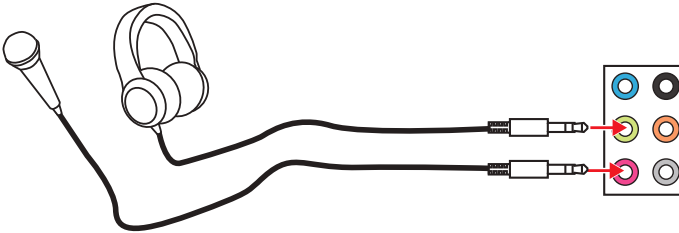

Audio jacks to stereo speakers diagram

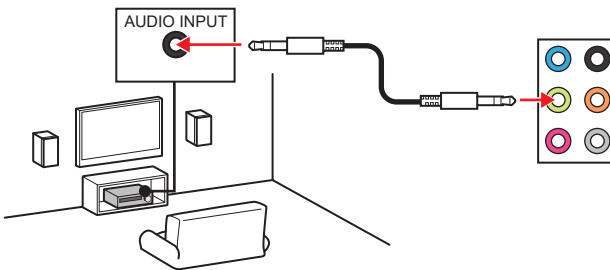

Audio jacks to 4-channel speakers diagram

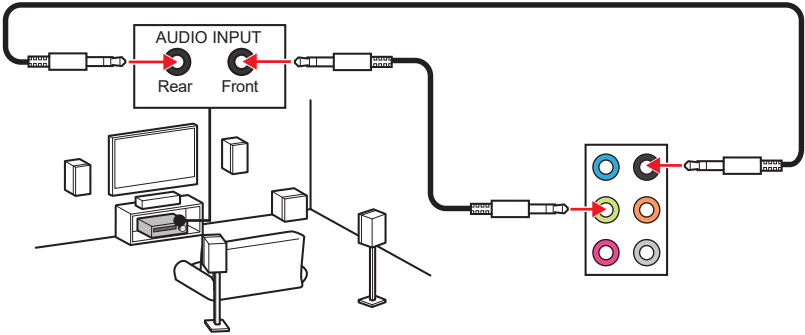

Audio jacks to 5.1-channel speakers diagram

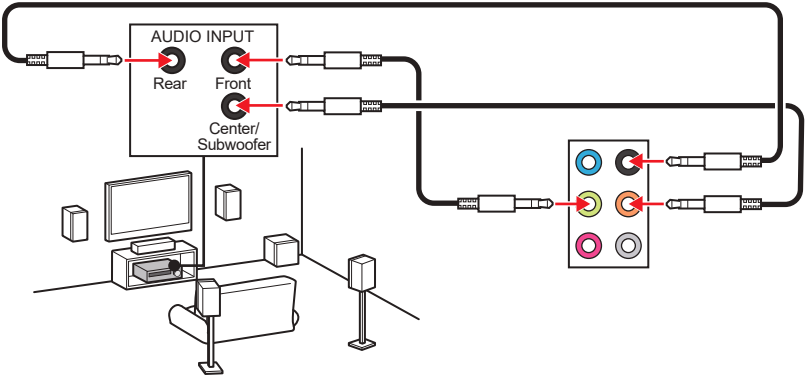

Audio jacks to 7.1-channel speakers diagram

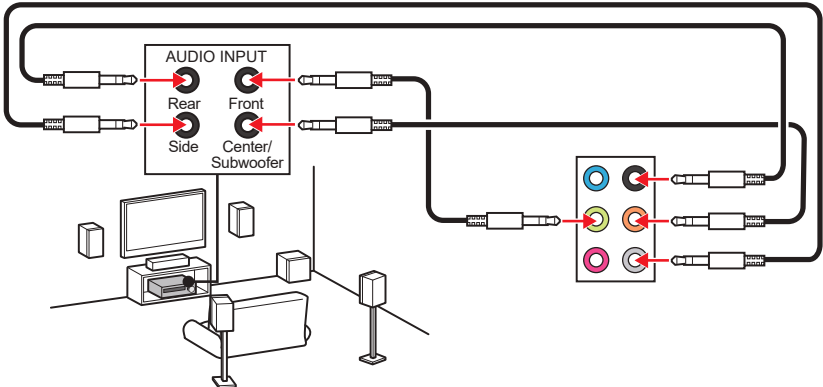

Installing Antennas

1. Screw the antennas tight to the antenna connectors as shown below.
2. Orient the antennas.

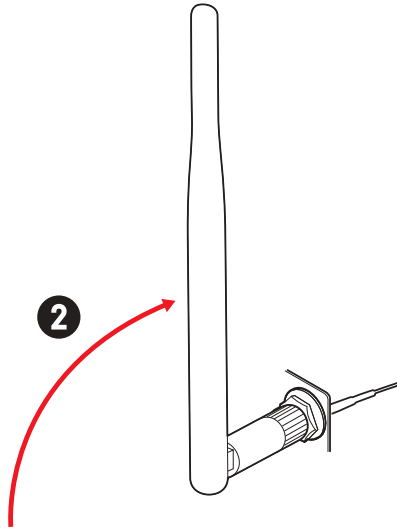
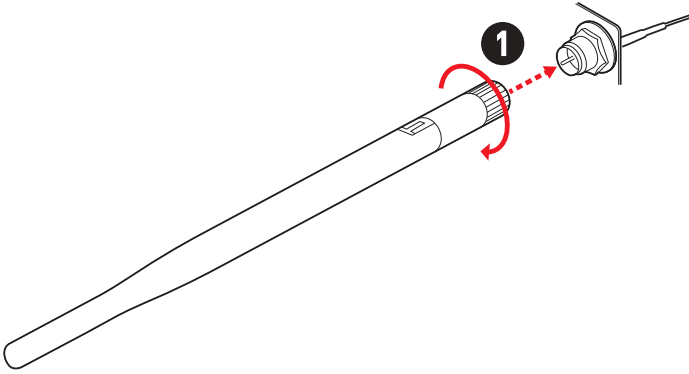

CPU Socket

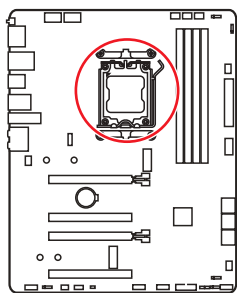

Distance from the center of the CPU to the nearest DIMM slot.

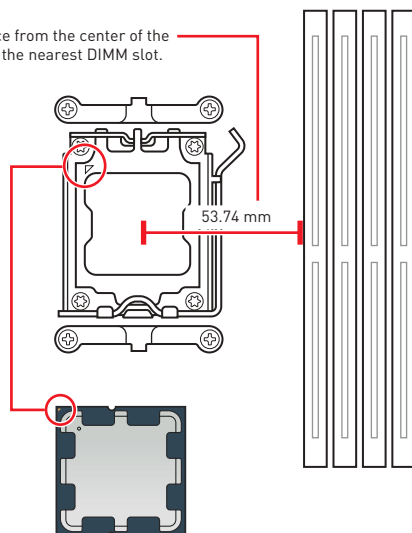

Introduction to the AM5 CPU

The surface of the AM5 CPU has two **notches** and a **golden triangle** to assist in correctly lining up the CPU for motherboard placement. The golden triangle is the Pin 1 indicator.

Important

- When changing the processor, the system configuration could be cleared and reset BIOS to default values, due to the AM5 processor's architecture.
- Always unplug the power cord from the power outlet before installing or removing the CPU.
- Please retain the CPU protective cap after installing the processor. MSI will deal with Return Merchandise Authorization (RMA) requests if only the motherboard comes with the protective cap on the CPU socket.
- When installing a CPU, always remember to install a CPU heatsink. A CPU heatsink is necessary to prevent overheating and maintain system stability.
- Confirm that the CPU heatsink has formed a tight seal with the CPU before booting your system.
- Overheating can seriously damage the CPU and motherboard. Always make sure the cooling fans work properly to protect the CPU from overheating. Be sure to apply an even layer of thermal paste (or thermal tape) between the CPU and the heatsink to enhance heat dissipation.
- Whenever the CPU is not installed, always protect the CPU socket pins by covering the socket with the plastic cap.
- If you purchased a separate CPU and heatsink/ cooler, Please refer to the documentation in the heatsink/ cooler package for more details about installation.
- This motherboard is designed to support overclocking. Before attempting to overclock, please make sure that all other system components can tolerate overclocking. Any attempt to operate beyond product specifications is not recommended. MSI® does not guarantee the damages or risks caused by inadequate operation beyond product specifications.

DIMM Slots

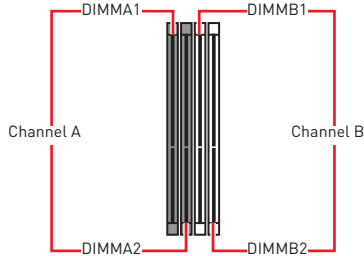
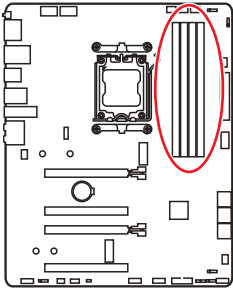

Memory module installation recommendation

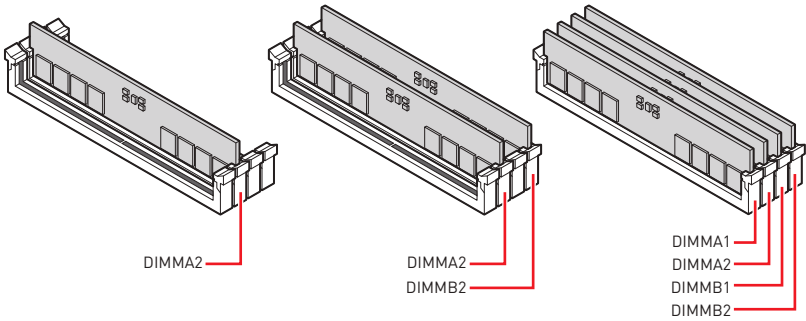

Important

- Always insert memory modules in the **DIMMA2** slot first.
- To ensure system stability for Dual channel mode, memory modules must be of the same type, number and density.
- Some memory modules may operate at a lower frequency than the marked value when overclocking due to the memory frequency operates dependent on its Serial Presence Detect (SPD). Go to BIOS and find the **DRAM Frequency** to set the memory frequency if you want to operate the memory at the marked or at a higher frequency.
- It is recommended to use a more efficient memory cooling system for full DIMMs installation or overclocking.
- The stability and compatibility of installed memory module depend on installed CPU and devices when overclocking.
- Please refer to www.msi.com for more information on compatible memory.

PCI_E1~4: PCIe Expansion Slots

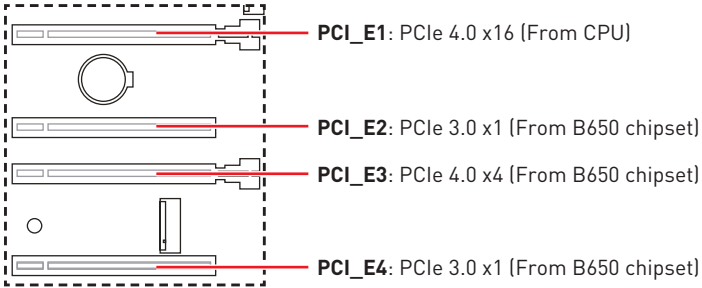

Important

- If you install a large and heavy graphics card, you need to use a tool such as **MSI Graphics Card Bolster** to support its weight to prevent deformation of the slot.
- For a single PCIe x16 expansion card installation with optimum performance, using the **PCI_E1** slot is recommended.
- When adding or removing expansion cards, always turn off the power supply and unplug the power supply power cable from the power outlet. Read the expansion card's documentation to check for any necessary additional hardware or software changes.

M2_1~2: M.2 Slots (Key M)

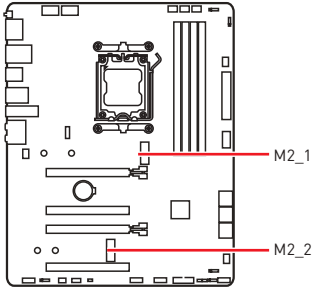

Important

If your M.2 SSD equips its own heatsink, please remove the M.2 plate or rubber cube in the M.2 slot before installing M.2 SSD. Do not re-install the heatsink supplied with your motherboard.

Installing M.2 module into M2_1 slot

1. Install the supplied EZ M.2 Clip kit in the M.2 slot according to 2280 SSD length.
Skip this step if you install 22110 SSD.

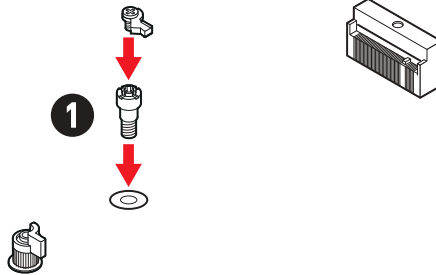

- 2. Insert your M.2 SSD into the M.2 slot at a 30-degree angle.
- 3. Rotate the EZ M.2 Clip to fix the M.2 SSD.

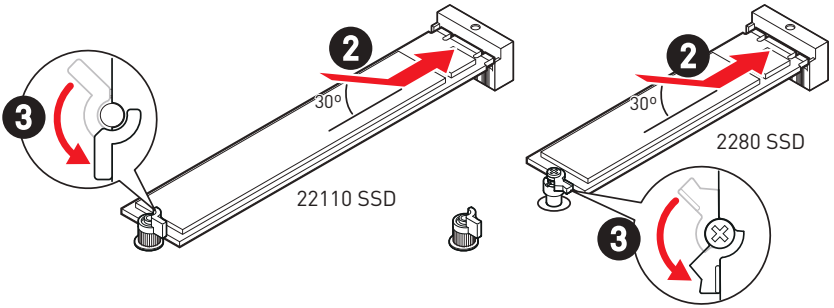

Installing M.2 module into M2_2 slot

1. Install the supplied EZ M.2 Clip kit in the M.2 slot according to your SSD length.
2. Insert your M.2 SSD into the M.2 slot at a 30-degree angle.
3. Rotate the EZ M.2 Clip to fix the M.2 SSD.

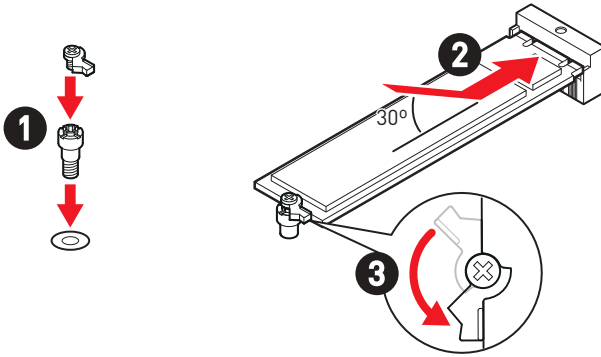

SATA_1~2, SATA_A1~A4: SATA 6Gb/s Connectors

These connectors are SATA 6Gb/s interface ports. Each connector can connect to one SATA device.

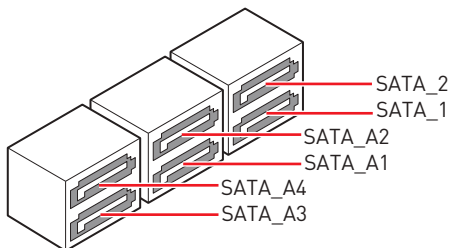
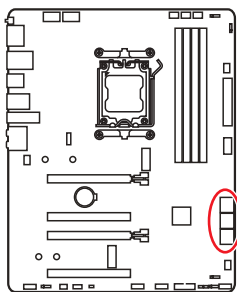

Important

- Please do not fold the SATA cable at a 90-degree angle. Data loss may result during transmission otherwise.
- SATA cables have identical plugs on either sides of the cable. However, it is recommended that the flat connector be connected to the motherboard for space saving purposes.

JAUD1: Front Audio Connector

This connector allows you to connect audio jacks on the front panel.

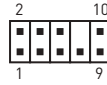
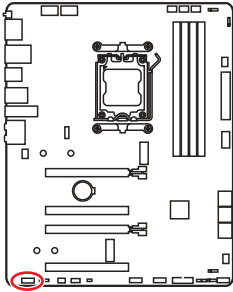

| Pin | Signal Name | Pin | Signal Name |
|-----|--------------|-----|----------------------|
| 1 | MIC L | 2 | Ground |
| 3 | MIC R | 4 | NC |
| 5 | Head Phone R | 6 | MIC Detection |
| 7 | SENSE_SEND | 8 | No Pin |
| 9 | Head Phone L | 10 | Head Phone Detection |

JFP1, JFP2: Front Panel Connectors

The JFP1 connector controls the power on, power reset, and the LEDs on your PC case/chassis. Power Switch/ Reset Switch headers allow you to connect power button/ reset button. Power LED header connects to LED light on the PC case, and HDD LED header indicates the activity of the hard disk. The JFP2 connector is for Buzzer and Speaker. To connect the cables from PC case to the right pins, please refer to the following images below.

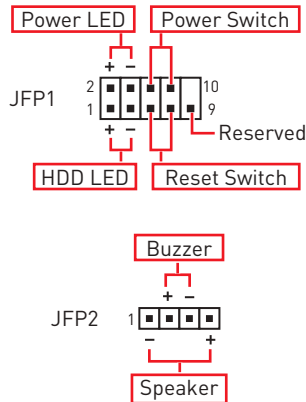
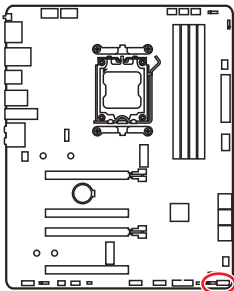

Important

Please note that Power LED and HDD LED have positive and negative connection, you need to link up the cable to the corresponding positive and negative port on the motherboard. Otherwise, LEDs won't work properly.

CPU_PWR1~2, ATX_PWR1: Power Connectors

These connectors allow you to connect an ATX power supply.

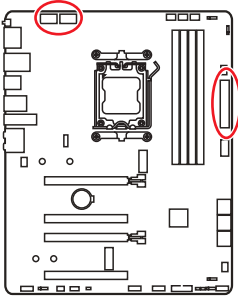

CPU_PWR1~2

| Pin | Signal Name | Pin | Signal Name |
|-----|-------------|-----|-------------|
| 1 | Ground | 2 | Ground |
| 3 | Ground | 4 | Ground |
| 5 | +12V | 6 | +12V |
| 7 | +12V | 8 | +12V |

ATX_PWR1

| Pin | Signal Name | Pin | Signal Name |
|-----|-------------|-----|-------------|
| 1 | +3.3V | 2 | +3.3V |
| 3 | Ground | 4 | +5V |
| 5 | Ground | 6 | +5V |
| 7 | Ground | 8 | PWR OK |
| 9 | 5VSB | 10 | +12V |
| 11 | +12V | 12 | +3.3V |
| 13 | +3.3V | 14 | -12V |
| 15 | Ground | 16 | PS-ON# |
| 17 | Ground | 18 | Ground |
| 19 | Ground | 20 | Res |
| 21 | +5V | 22 | +5V |
| 23 | +5V | 24 | Ground |

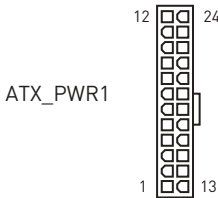
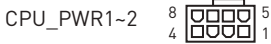

Important

- Make sure that all the power cables are securely connected to a proper ATX power supply to ensure stable operation of the motherboard.

JCI1: Chassis Intrusion Connector

This connector allows you to connect the chassis intrusion switch cable.

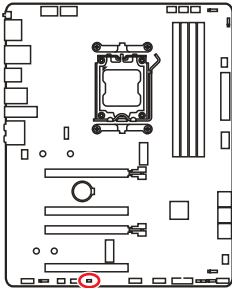

Normal
(default)



Trigger the chassis
intrusion event

Using chassis intrusion detector

1. Connect the **JCI1** connector to the chassis intrusion switch/ sensor on the chassis.
2. Close the chassis cover.
3. Go to **BIOS > SETTINGS > Security > Chassis Intrusion Configuration**.
4. Set **Chassis Intrusion** to **Enabled**.
5. Press **F10** to save and exit and then press the **Enter** key to select **Yes**.
6. Once the chassis cover is opened again, a warning message will be displayed on screen when the computer is turned on.

Resetting the chassis intrusion warning

1. Go to **BIOS > SETTINGS > Security > Chassis Intrusion Configuration**.
2. Set **Chassis Intrusion** to **Reset**.
3. Press **F10** to save and exit and then press the **Enter** key to select **Yes**.

JUSB1: USB 3.2 Gen 2 10Gbps Type-C front panel Connector

This connector allows you to connect USB Type-C connector on the front panel. The connector possess a foolproof design. When you connect the cable, be sure to connect it with the corresponding orientation.

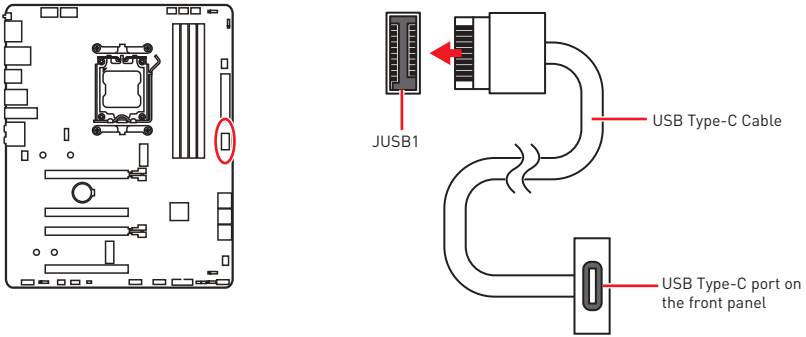

JUSB2: USB 3.2 Gen 1 Connector

These connectors allow you to connect USB 3.2 Gen 1 5Gbps ports on the front panel.

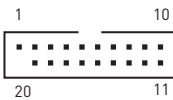
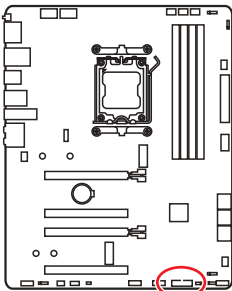

| Pin | Signal Name | Pin | Signal Name |
|-----|--------------|-----|--------------|
| 1 | Power | 2 | USB3_RX_DN |
| 3 | USB3_RX_DP | 4 | Ground |
| 5 | USB3_TX_C_DN | 6 | USB3_TX_C_DP |
| 7 | Ground | 8 | USB2.0- |
| 9 | USB2.0+ | 10 | Ground |
| 11 | USB2.0+ | 12 | USB2.0- |
| 13 | Ground | 14 | USB3_TX_C_DP |
| 15 | USB3_TX_C_DN | 16 | Ground |
| 17 | USB3_RX_DP | 18 | USB3_RX_DN |
| 19 | Power | 20 | No Pin |

Important

Note that the Power and Ground pins must be connected correctly to avoid possible damage.

JUSB3~4: USB 2.0 Connectors

These connectors allow you to connect USB 2.0 ports on the front panel.

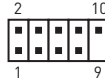
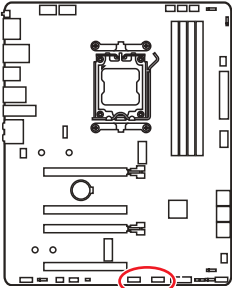

| Pin | Signal Name | Pin | Signal Name |
|-----|-------------|-----|-------------|
| 1 | VCC | 2 | VCC |
| 3 | USB0- | 4 | USB1- |
| 5 | USB0+ | 6 | USB1+ |
| 7 | Ground | 8 | Ground |
| 9 | No Pin | 10 | NC |

Important

- Note that the VCC and Ground pins must be connected correctly to avoid possible damage.
- In order to recharge your iPad, iPhone and iPod through USB ports, please install MSI Center utility.

JTPM1: TPM Module Connector

This connector is for TPM (Trusted Platform Module). Please refer to the TPM security platform manual for more details and usages.

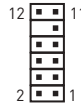
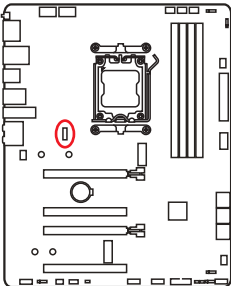

| Pin | Signal Name | Pin | Signal Name |
|-----|--------------------------------|-----|--------------------------------|
| 1 | SPI Power | 2 | SPI Chip Select |
| 3 | Master In Slave Out (SPI Data) | 4 | Master Out Slave In (SPI Data) |
| 5 | Reserved | 6 | SPI Clock |
| 7 | Ground | 8 | SPI Reset |
| 9 | Reserved | 10 | No Pin |
| 11 | Reserved | 12 | Interrupt Request |

CPU_FAN1, PUMP_FAN1, SYS_FAN1~4: Fan Connectors

Fan connectors can be classified as PWM (Pulse Width Modulation) Mode or DC Mode. PWM Mode fan connectors provide constant 12V output and adjust fan speed with speed control signal. DC Mode fan connectors control fan speed by changing voltage. The auto mode fan connectors can automatically detect PWM and DC mode.

You can control fans in **BIOS> HARDWARE MONITOR** panel. It allows you to set DC or PWM to your fan type. Check the **Smart Fan Mode**, the fan speed will change according to the CPU or system temperature. Uncheck the **Smart Fan Mode**, the fan will spin at maximum speed.



Important

Make sure fans are working properly after switching the PWM/ DC mode.

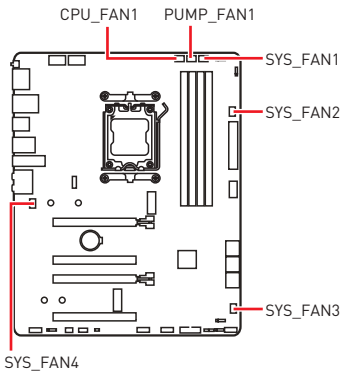

PWM Mode pin definition

| Pin | Signal Name | Pin | Signal Name |
|-----|-------------|-----|----------------------|
| 1 | Ground | 2 | +12V |
| 3 | Sense | 4 | Speed Control Signal |

DC Mode pin definition

| Pin | Signal Name | Pin | Signal Name |
|-----|-------------|-----|-----------------|
| 1 | Ground | 2 | Voltage Control |
| 3 | Sense | 4 | NC |

Fan connector specifications

| Connector | Default fan mode | Max. current | Max. power |
|------------|------------------|--------------|------------|
| CPU_FAN1 | Auto mode | 3A | 36W |
| PUMP_FAN1 | PWM mode | 3A | 36W |
| SYS_FAN1~4 | DC mode | 2A | 24W |

JBAT1: Clear CMOS (Reset BIOS) Jumper

There is CMOS memory onboard that is external powered from a battery located on the motherboard to save system configuration data. If you want to clear the system configuration, set the jumpers to clear the CMOS memory.

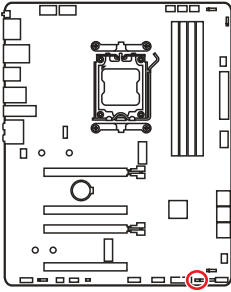

Keep Data
(default)



Clear CMOS/
Reset BIOS

Resetting BIOS to default values

1. Power off the computer and unplug the power cord.
2. Use a jumper cap to short **JBAT1** for about 5-10 seconds.
3. Remove the jumper cap from **JBAT1**.
4. Plug the power cord and Power on the computer.

JRGB1~2: RGB LED connectors

The JRGB connectors allow you to connect the 5050 RGB LED strips 12V.

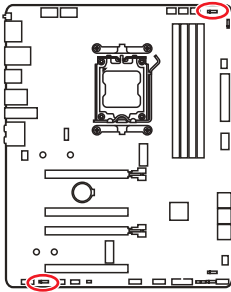

| Pin | Signal Name | Pin | Signal Name |
|-----|-------------|-----|-------------|
| 1 | +12V | 2 | G |
| 3 | R | 4 | B |

RGB LED Strip Connection

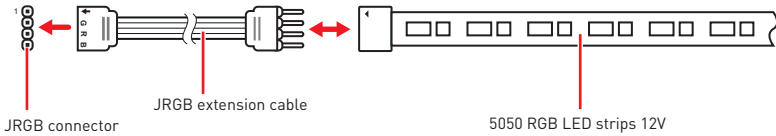

RGB LED Fan Connection

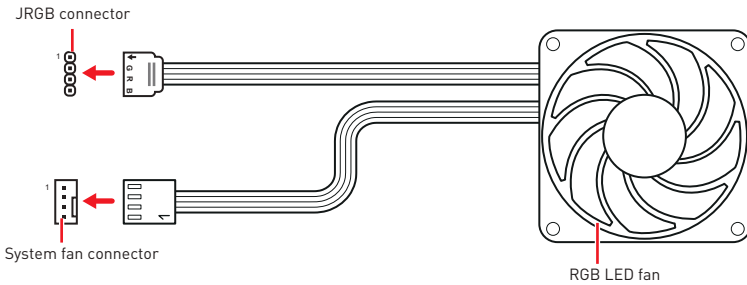

Important

- The JRGB connector supports up to 2 meters continuous 5050 RGB LED strips (12V/G/R/B) with the maximum power rating of 3A (12V).
- Always turn off the power supply and unplug the power cord from the power outlet before installing or removing the RGB LED strip.
- Please use MSI's software to control the extended LED strip.

JARGB_V2_1~2: A-RAINBOW V2 (ARGB Gen2) LED connectors

The JARGB_V2 connectors allow you to connect the ARGB Gen2 and the ARGB-based LED strips. The JARGB_V2 connector supports up to 240 individually addressable RGB LEDs with maximum power rating of 3A (5V).

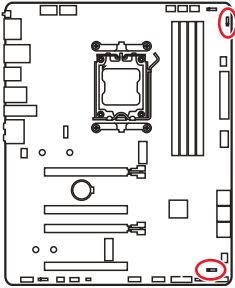

| Pin | Signal Name | Pin | Signal Name |
|-----|-------------|-----|-------------|
| 1 | +5V | 2 | Data |
| 3 | No Pin | 4 | Ground |

Addressable RGB LED Strip Connection

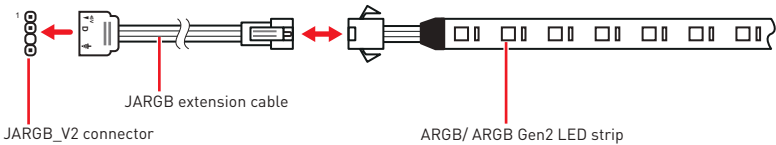

Addressable RGB LED Fan Connection

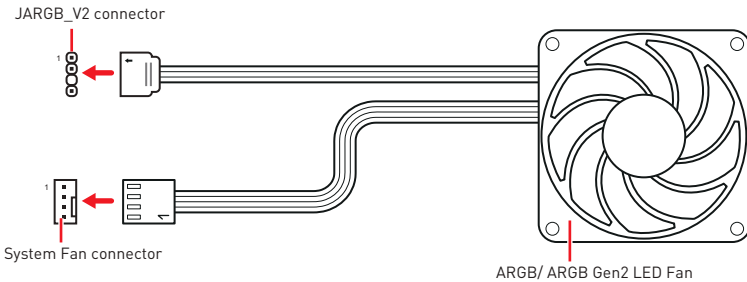

 **CAUTION**

Do not connect the wrong type of LED strips. The JRGB connector and the JARGB_V2 connector provide different voltages, and connecting the ARGB 5V LED strip to the JRGB connector will result in damage to the LED strip.

 **Important**

- *If you connect the ARGB Gen1 and ARGB Gen2 LED strips into the same connector, it may cause some issues. Please do not mix the ARGB Gen1 LED and the ARGB Gen2 LED strips together.*
- *It is recommended that you install LED strips with the same specification to achieve the best effects.*
- *Always turn off the power supply and unplug the power cord from the power outlet before installing or removing the addressable RGB LED strip.*
- *Please use MSI's software to control the extended LED strip.*

JOCFS1: Safe Boot Jumper

This jumper is used for Safe Boot. Once enabled, the system will boot with default settings and lower PCIe (from CPU) mode.

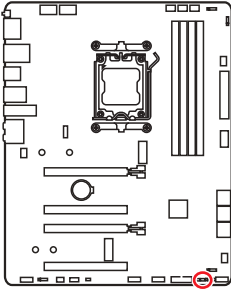

Normal
(default)

Boot with the saved
BIOS settings.



Enabled

Apply the BIOS default
settings and lower PCIe
(from CPU) mode for
Safe Boot.

JDASH1 : Tuning Controller connector

This connector is used to connect an optional Tuning Controller module.

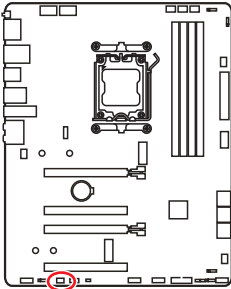

| Pin | Signal Name | Pin | Signal Name |
|-----|---------------|-----|---------------|
| 1 | No Pin | 2 | NC |
| 3 | MCU_SMB_SCL_M | 4 | MCU_SMB_SDA_M |
| 5 | VCC5 | 6 | Ground |

Onboard LEDs

EZ Debug LED

These LEDs indicate the debug status of the motherboard.

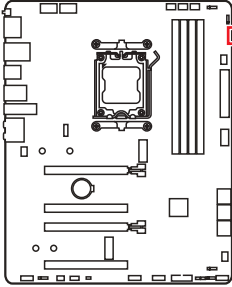

- CPU** - indicates CPU is not detected or fail.
- DRAM** - indicates DRAM is not detected or fail.
- VGA** - indicates GPU is not detected or fail.
- BOOT** - indicates the booting device is not detected or fail.

LED_SW1: EZ LED Control

This switch is used to switch on/ off all the LEDs of motherboard.

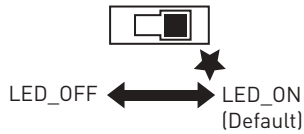
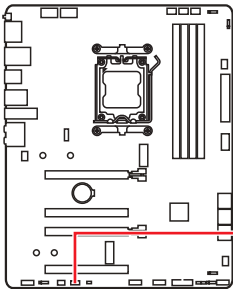

Installing OS, Drivers & MSI Center

Please download and update the latest utilities and drivers at www.msi.com

Installing Windows 10/ Windows 11

1. Power on the computer.
2. Insert the Windows 10/ Windows 11 installation disc/USB into your computer.
3. Press the **Restart** button on the computer case.
4. Press **F11** key during the computer POST (Power-On Self Test) to get into Boot Menu.
5. Select the Windows 10/ Windows 11 installation disc/USB from the Boot Menu.
6. Press any key if screen shows **Press any key to boot from CD or DVD...** message. If not, please skip this step.
7. Follow the instructions on the screen to install Windows 10/ Windows 11.

Installing Drivers with MSI Driver Utility Installer

Important

- Some new network chips have not been natively supported by Windows 10/ Windows 11. It is recommended that the LAN driver be installed before installing drivers with MSI Driver Utility Installer. Please refer to www.msi.com to install the LAN driver for your motherboard.
 - The MSI Driver Utility Installer will only pop up once. If you cancel or close it during the process, please refer to the Live Update chapter of the MSI Center manual to install the drivers. You can also go to www.msi.com to search your motherboard and download the drivers.
 - MSI Driver Utility Installer needs to be installed over the internet.
1. Start up your computer in Windows 10/ Windows 11.
 2. Select **Start > Settings > Windows Update**, and then select **Check** for updates.
 3. MSI Driver Utility Installer will pop up automatically.



4. Select the **I have read and agree to the MSI Terms of Use** check box, and then click **Next**.

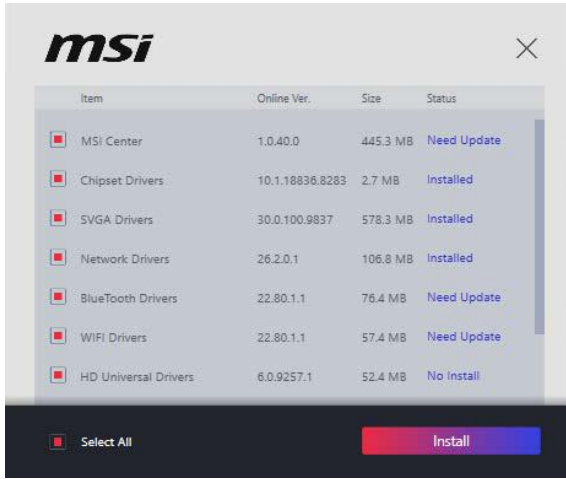

5. Check the **Select All** checkbox in the lower-left corner and click **Install** to install MSI Center and drivers. The installation progress will be shown at the bottom.



6. Once the progress has completed, click **Finish**.

MSI Center

MSI Center is an application that helps you easily optimize game settings and smoothly use content creation softwares. It also allows you to control and synchronize LED light effects on PCs and other MSI products. With MSI Center, you can customize ideal modes, monitor system performance, and adjust fan speed.

MSI Center User Guide



If you would like to know more information about MSI Center, please refer to

<http://download.msi.com/manual/mb/MSICENTER.pdf>

or scan the QR code to access.



Important

Functions may vary depending on the product you have.

UEFI BIOS

MSI UEFI BIOS is compatible with UEFI (Unified Extensible Firmware Interface) architecture. UEFI has many new functions and advantages that traditional BIOS cannot achieve, and it will completely replace BIOS in the future. The MSI UEFI BIOS uses UEFI as the default boot mode to take full advantage of the new chipset's capabilities.



The term BIOS in this user guide refers to UEFI BIOS unless otherwise noted.

UEFI advantages

- Fast booting - UEFI can directly boot the operating system and save the BIOS self-test process. And also eliminates the time to switch to CSM mode during POST.
- Supports for hard drive partitions larger than 2 TB.
- Supports more than 4 primary partitions with a GUID Partition Table (GPT).
- Supports unlimited number of partitions.
- Supports full capabilities of new devices - new devices may not provide backward compatibility.
- Supports secure startup - UEFI can check the validity of the operating system to ensure that no malware tampers with the startup process.

Incompatible UEFI cases

- **32-bit Windows operating system** - this motherboard supports only Windows 10/Windows 11 64-bit operating system.
- **Older graphics card** - the system will detect your graphics card. If you use older graphics cards, it may display a warning message **There is no GOP (Graphics Output protocol) support detected in this graphics card.**



We recommend that you replace it with a graphics card supporting GOP/UEFI or use CPU with integrated graphics for having normal function.

How to check the BIOS mode?

1. Power on your computer.
2. Press **Delete** key, when the **Press DEL key to enter Setup Menu, F11 to enter Boot Menu** message appears on the screen during the boot process.
3. After entering the BIOS, you can check the **BIOS Mode** at the top of the screen.

BIOS Mode: UEFI

BIOS Setup

The default settings offer the optimal performance for system stability in normal conditions. You should **always keep the default settings** to avoid possible system damage or failure booting unless you are familiar with BIOS.



Important

- BIOS items are continuously update for better system performance. Therefore, the description may be slightly different from the latest BIOS and should be for reference only. You could also refer to the **HELP** information panel for BIOS item description.
- The BIOS screens, options and settings will vary depending on your system.

Entering BIOS Setup

Press **Delete** key, when the **Press DEL key to enter Setup Menu, F11 to enter Boot Menu** message appears on the screen during the boot process.

Function key

- F1:** General Help list
- F2:** Add/ Remove a favorite item
- F3:** Enter Favorites menu
- F4:** Enter CPU Specifications menu
- F5:** Enter Memory-Z menu
- F6:** Load optimized defaults
- F7:** Switch between Advanced mode and EZ mode
- F8:** Load Overclocking Profile
- F9:** Save Overclocking Profile
- F10:** Save Change and Reset*
- F12:** Take a screenshot and save it to USB flash drive (FAT/ FAT32 format only).
- Ctrl+F:** Enter Search page

* When you press F10, a confirmation window appears and it provides the modification information. Select between Yes or No to confirm your choice.

BIOS User Guide



If you'd like to know more instructions on setting up the BIOS, please refer to https://download.msi.com/archive/mnu_exe/mb/AMDAM5BIOS.pdf or scan the QR code to access.



Important

Functions may vary depending on the product you have.

Resetting BIOS

You might need to restore the default BIOS setting to solve certain problems. There are several ways to reset BIOS:

- Go to BIOS and press **F6** to load optimized defaults.
- Short the **Clear CMOS** jumper on the motherboard.



*Be sure the computer is off before clearing CMOS data. Please refer to the **Clear CMOS jumper** section for resetting BIOS.*

Updating BIOS

Updating BIOS with M-FLASH

Before updating:

Please download the latest BIOS file that matches your motherboard model from MSI website. And then save the BIOS file into the USB flash drive.

Updating BIOS:

1. Switch to the target BIOS ROM by Multi-BIOS switch. Please skip this step if your motherboard doesn't have this switch.
2. Insert the USB flash drive that contains the update file into the USB port.
3. Please refer the following methods to enter flash mode.
 - Reboot and press **Ctrl + F5** key during POST and click on Yes to reboot the system.

Press <Ctrl+F5> to activate M-Flash for BIOS update.

- Reboot and press **Del** key during POST to enter BIOS. Click the **M-FLASH** button and click on Yes to reboot the system.

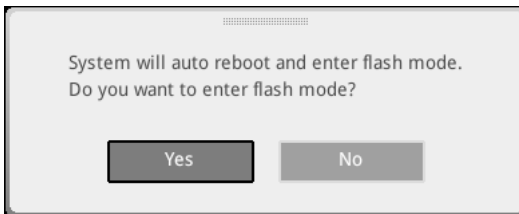

4. Select a BIOS file to perform the BIOS update process.
5. When prompted click on **Yes** to start recovering BIOS.
6. After the flashing process is 100% completed, the system will reboot automatically.

Updating the BIOS with MSI Center

Before updating:

- Make sure the LAN driver is already installed and the internet connection is set properly.
- Please close all other application software before updating the BIOS.

To update BIOS:

1. Install and launch MSI Center and go to **Support** page.
2. Select **Live Update** and click on **Advance** button.
3. Select the BIOS file and click on **Install** button.
4. The installation reminder will appear, then click the **Install** button.
5. The system will automatically restart to update BIOS.
6. After the flashing process is 100% completed, the system will restart automatically.

Updating BIOS with Flash BIOS Button

1. Please download the latest BIOS file that matches your motherboard model from the MSI® website.
2. Rename the BIOS file to MSI.ROM, and save it to the root of the USB storage device.
3. Connect the power supply to **CPU_PWR1** and **ATX_PWR1**. (No need to install CPU and memory.)
4. Plug the USB storage device that contains the MSI.ROM file into the **Flash BIOS Port** on the rear I/O panel.
5. Press the **Flash BIOS Button** to update BIOS, and the LED starts flashing.
6. The LED will be off when the process is completed.

Copyright and Trademarks Notice



Copyright © Micro-Star Int'l Co., Ltd. All rights reserved. The MSI logo used is a registered trademark of Micro-Star Int'l Co., Ltd. All other marks and names mentioned may be trademarks of their respective owners. No warranty as to accuracy or completeness is expressed or implied. MSI reserves the right to make changes to this document without prior notice.



The terms HDMI™, HDMI™ High-Definition Multimedia Interface, HDMI™ Trade dress and the HDMI™ Logos are trademarks or registered trademarks of HDMI™ Licensing Administrator, Inc.

Technical Support

If a problem arises with your system and no solution can be obtained from the user guide, please contact your place of purchase or local distributor. Alternatively, please try the following help resources for further guidance.

- Visit the MSI website for technical guide, BIOS updates, driver updates, and other information: <http://www.msi.com>
- Register your product at: <http://register.msi.com>

Revision History

- Version 1.3, 2023/07, First release for PRO B650-VC WIFI.
- Version 1.5, 2024/02, add PHX CPU support information.
- Version 1.7, 2024/02, Add battery safety warning.
- Version 1.9, 2024/08, update M.2 information.

