

Prima

AP 6.5P

Woofer 330 W Peak Power 165 mm 4 ohm

AP 6.5P woofer component has been designed to perform at its best in OEM placements, combining excellent power handling and efficiency featuring a very wide excursion to cope with the most important dynamic peaks without any compression. Its impressive magnetic assembly provides the energy needed for perfect control even during limit excursions. The CCAW (Copper Clad Aluminium Wire) voice coil (32 x 14 mm, 1.25 x 0.55 in) optimally manages the greater applied power. The basket was completely redesigned with the aid of simulations to lower the resistance of air flows, while maintaining compact sizes to facilitate the installation.



TECHNICAL SPECS

Nominal diameter Inch	6.5 in
Nominal diameter	165 mm
Impedance	4
Power Handling - Peak	330 W
Power Handling - Continuous	110 W
Sensitivity	92.5 dB
Frequency Response	50 - 5k Hz
Voice Coil Ø	32 mm
Magnet size D x d x h	100 x 40 x 18 mm (in.)
Voice Coil Material	CCA W
Cone Material	WATER-REPELLENT TREATED PAPER CONE
Xmax Inch	0.22 in
Xmax	5.6 mm

ELECTRIC-ACOUSTIC SPECS

Re	3.1 Ohm
Fs	60 Hz
Le	0.29 mH
Vas Ft	0.403 ft
Vas	11.4 l
Mms Oz	0.515 oz
Mms	14.6 g

Cms	0.47 mm/N
BL	5.35 T•m
Qts	0.55
Qes	0,6
Qms	7.6

GENERAL

Weight	1.45 kg
--------	---------

DIMENSIONS

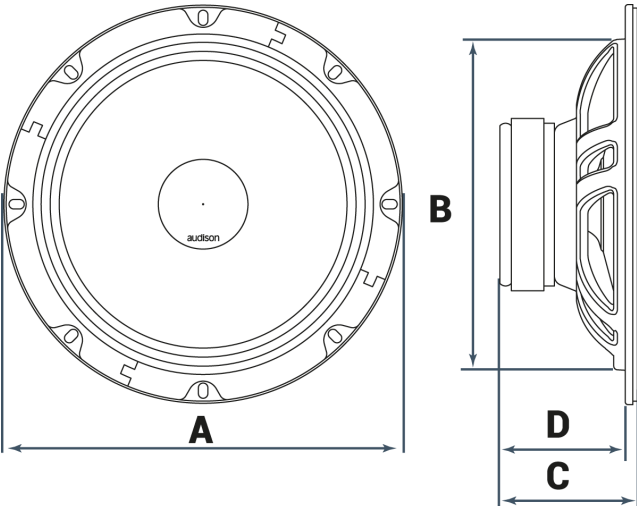

Dimension A Inch	6.5 in
Dimension A	165 mm
Dimension B Inch	5.55 in
Dimension B	141 mm
Dimension C Inch	2.95 in
Dimension C	75 mm
Dimension D Inch	2.62 in
Dimension D	66.5 mm