



Chevrolet **Silverado 1500** (excluding WT Trim) **2019**

Chevrolet **Silverado 1500/2500/3500**
(excluding WT Trim)* **2019-2020**

GMC **Sierra 1500*** **2019**

GMC **Sierra 1500/2500/3500** **2019-2020**

*Models with a 2 knob 8-inch screen radio, RPO code IOS or IOT.

The RPO code can be found in the **Vehicle Certification** Label located on the inside of the driver's door opening.

A mobile device with a QR scanner must be used to decipher the code.

KIT COMPONENTS

•A) Display screen housing • B) Display screen brackets • C) Blank-out panel

Not Shown: Radio Interface, LD-GM30-PIO, LD-GM31-PIO, AXEXH-GM30, AXEXH-GM31, AD-EU5, 40-GPS-PIO, PR04AVIC-PIO / PR04-PIORCA, LD-AX-SPK

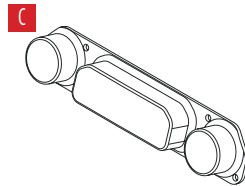
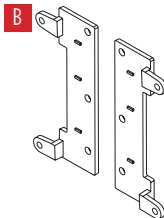
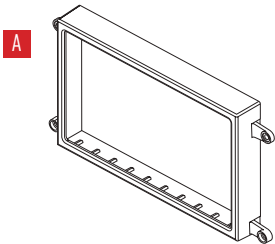

Visit AxxessInterfaces.com for more detailed information about the product and up-to-date vehicle specific applications.

TABLE OF CONTENTS

Kit Features	2
Speaker Installation.....	2
Dash Disassembly	3-4
Connections.....	5
Radio Tuner Location.....	6
Kit Preparation.....	7
Kit Assembly	8
Radio Operations	9-10

WIRING & ANTENNA CONNECTIONS (sold separately)

- RGB Extension Cable: Pioneer part # CD-RGB150A (not sold by Metra)

TOOLS REQUIRED

- Panel removal tool • Phillips screwdriver
- 9/32" socket wrench • T-15 Torx screwdriver

ATTENTION: With the key out of the ignition, disconnect the negative battery terminal before installing this product. Ensure that all installation connections, especially the air bag indicator lights, are plugged in before reconnecting the battery or cycling the ignition to test this product.

NOTE: Refer also to the instructions included with the aftermarket accessory before installing this device.

KIT FEATURES

KIT FEATURES

- Designed for Pioneer DMH-WC5700NEX receivers
- Allows for the retention and adjustment of the factory personalization menu through the Pioneer radio
- Provides a visual view of HVAC and gauges on the Pioneer screen (cannot be adjusted via the screen)
- Complete Plug-n-Play installation
- Includes dash kit with Axxess interface and vehicle-specific T-harness
- Includes radio antenna adaptor for GPS
- Provides accessory power (12-volt 10-amp)
- Provides NAV outputs (parking brake, reverse, speed sense)
- Retains audio controls on the steering wheel
- Works in both single and dual-zone vehicles
- Retains safety chimes through an included off-board speaker
- USB Micro “B” USB updatable
- Dash kit is painted scratch-resistant matte black to match the factory finish
- For non-amplified vehicles only

DASH DISASSEMBLY

For models with a full center console:

1. Pop out the screw cover from the driver's side of the center console, then remove (1) 9/32" screw exposed. (Figure A)
2. Using the panel removal tool and starting from the rear, unclip and remove the center console trim panel from each side of the center console. (Figure B)
3. Starting from the rear, unsnap and remove the cup holder panel. (Figure C)
4. Unclip and remove the lower trim panel. (Figure D)
5. Using the panel removal tool, unclip and remove the trim panel surrounding the radio display. (Figure E)
6. Remove (6) 9/32" screws securing the radio/climate control panel, then unplug and remove the radio. (Figure F)

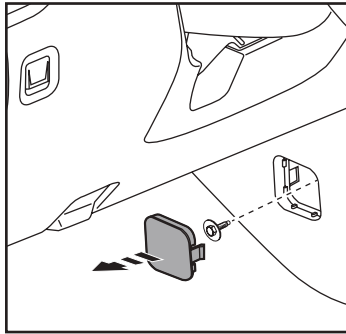

(Figure A)

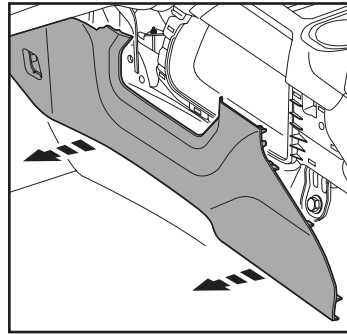

(Figure B)

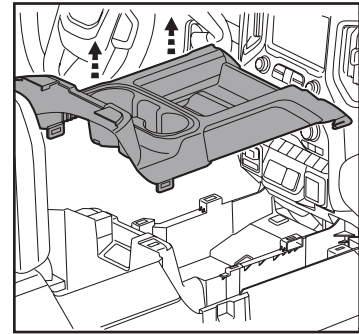

(Figure C)

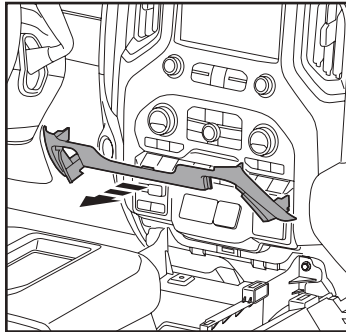

(Figure D)

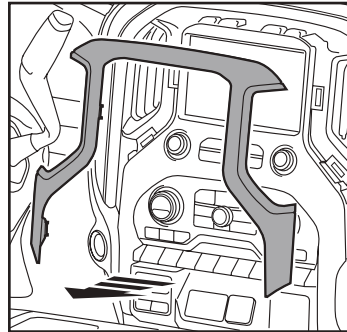

(Figure E)

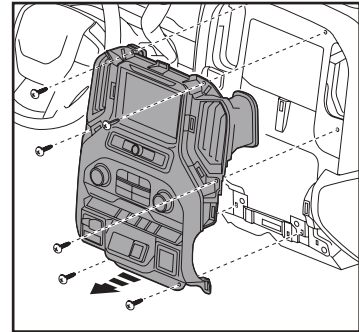

(Figure F)

Continue to Kit Preparation

DASH DISASSEMBLY (CONT.)

For models without a full center console:

1. Unsnap and remove the lower trim panel. (Figure A)
2. Using the panel removal tool, carefully unclip and remove the trim panel surrounding the radio display. (Figure B)
3. Remove (6) 9/32" screws securing the radio/climate control panel, then unplug and remove the radio. (Figure C)

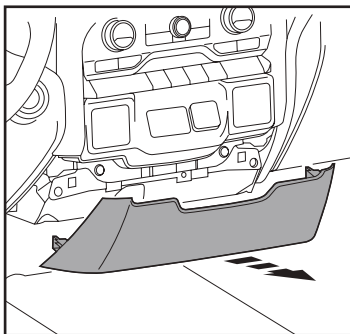

(Figure A)

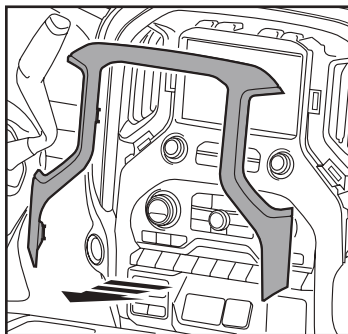

(Figure B)

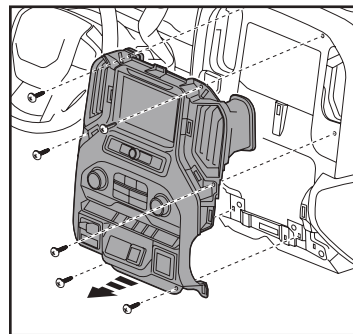

(Figure C)

CONNECTIONS

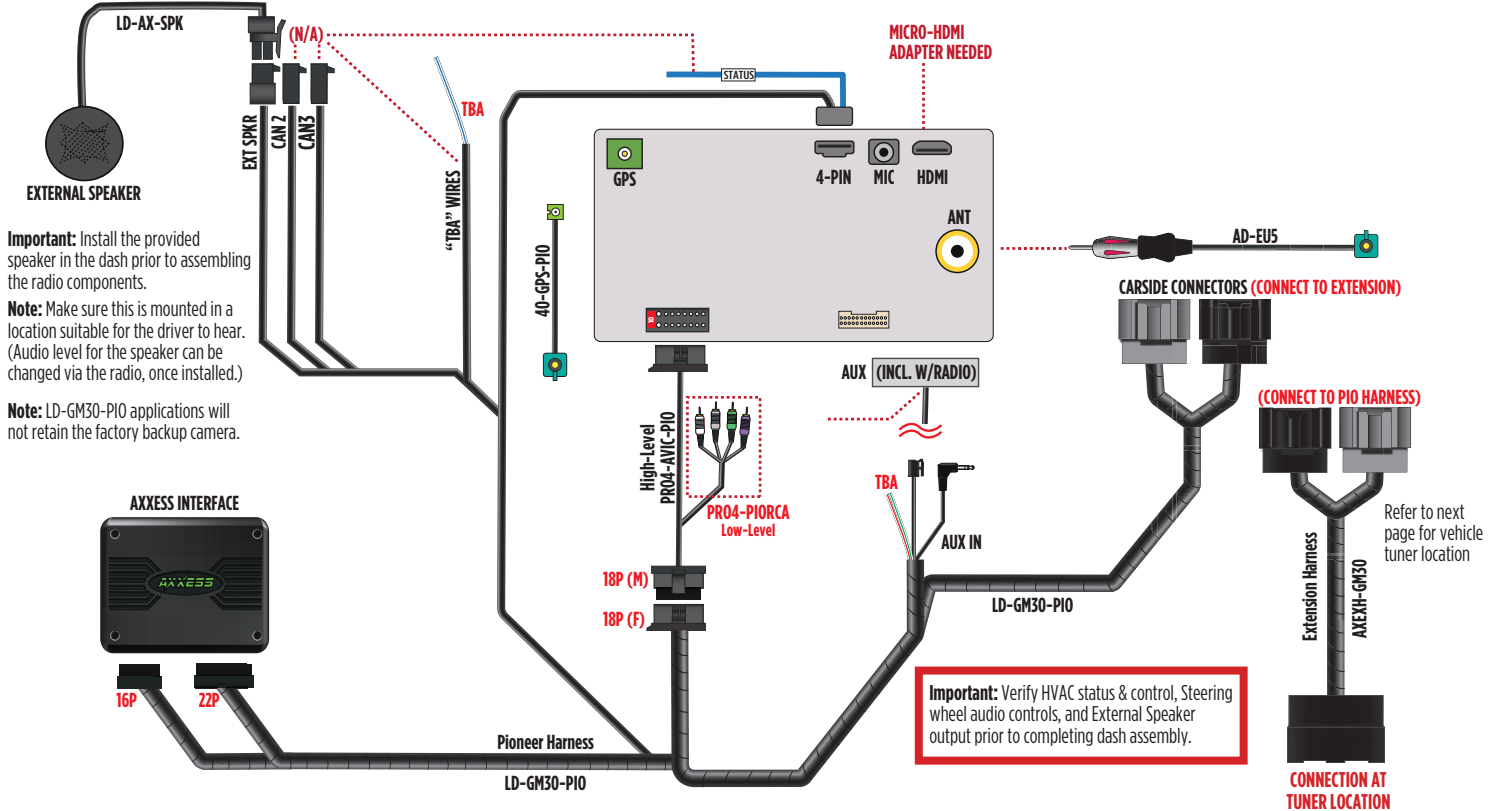

RADIO TUNER LOCATION

AXEXH-GM30 will get connected at Tuner underneath glovebox.

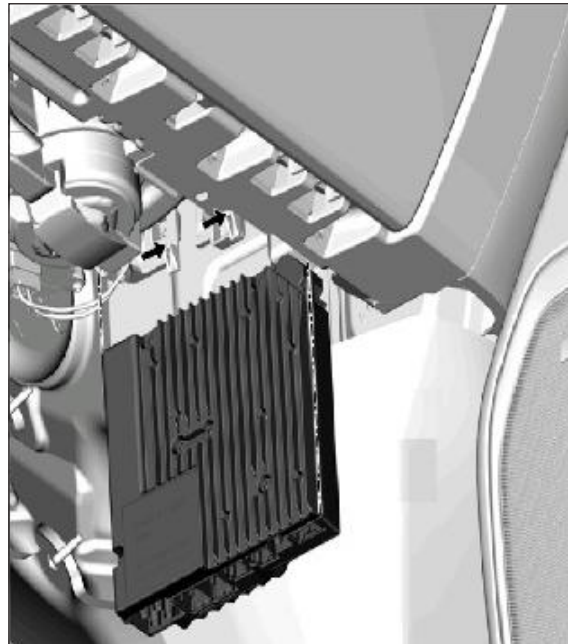

KIT PREPARATION

From the factory climate and radio control panel:

1. Remove (10) T-15 Torx screws securing the cover from the back of the radio. (Figure A)
2. Slightly lift up the bottom of the cover to access the ribbon cable securing the radio display to the radio controls. Unplug the cable, then remove the display.
3. Remove (4) T-15 Torx screws securing the radio controls, then remove. (Figure B)
4. Place the **blank out panel** into the panel, then secure using the factory screws. (Figure C)

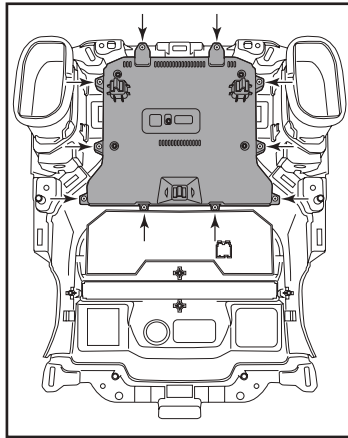

(Figure A)

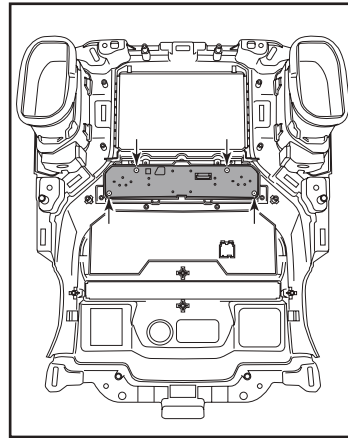

(Figure B)

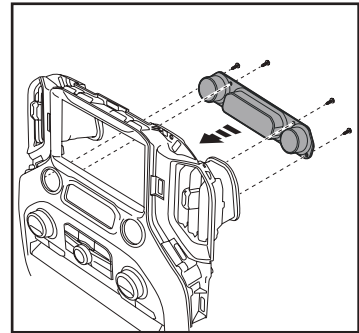

(Figure C)

Continue to Kit Assembly

KIT ASSEMBLY

1. Secure the display screen to the *display screen brackets* using (6) screws supplied with the radio. (Figure A)
Note: Reference the installation manual provided with the radio for which hard-ware to use. The display screen and radio chassis use two different types of screws.
2. Find a suitable location for the radio chassis. Route the RGB extension cable from the radio chassis to the display screen, then connect it to the display screen.
3. Place the display screen assembly into the *display screen housing*, then secure the entire assembly to the factory radio panel using the factory screws. (Figures B, C)

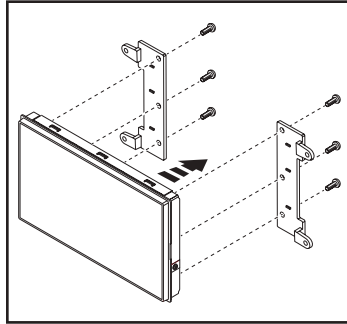

(Figure A)

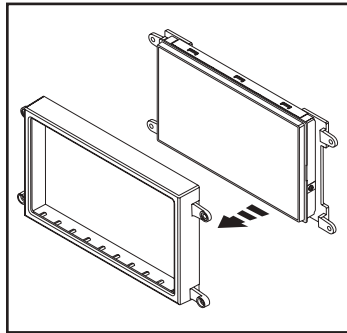

(Figure B)

4. Locate the factory wiring harness and antenna connector in the dash and complete all necessary connections to the radio assembly. Metra recommends using the proper mating adapter from Metra and/or Axxess.
5. Reconnect the negative battery terminal and test the Pioneer radio for proper operation.
Note: Temporarily plug the climate control panel back in during testing to avoid vehicle errors codes.
6. Mount the radio assembly into the dash using the factory screws and reassemble the dash in reverse order of disassembly to complete the installation

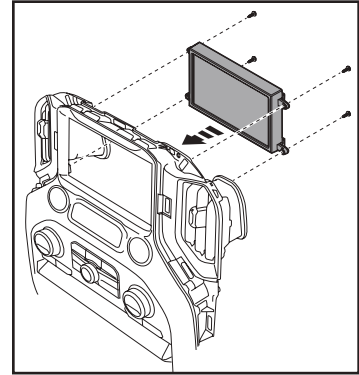

(Figure C)

RADIO OPERATIONS

Vehicle Selection

- Allows the selection of the vehicle the Pioneer radio is being installed in.
- Select Make, Model and Trim to activate the extended functions of the radio.
- The vehicle type must be selected to activate iPod, Bluetooth, backup cameras, as well as, HVAC functions and steering wheel controls.
- Press Confirm to lock in the selection.



Car Features

The source for accessing all vehicle information and options.



RADIO OPERATIONS (CONT.)

Customizations Menu : Allows full control of vehicle personalization options.

Access this menu by selecting the gear icon on the previous screenshot:

- Provides Steering Wheel Control (SWC) Configuration.
- Dual Assignment: Assign (2) functions to a single SWC button.
- Remap: Reassign a button on the SWC.

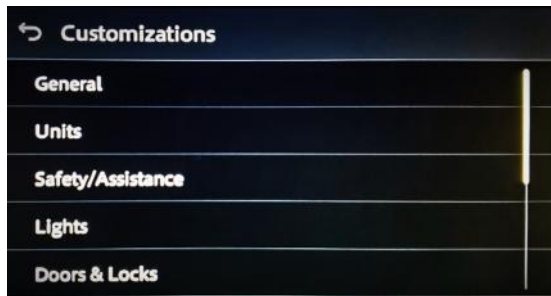

Climate Screen: HVAC Status only



Vehicle Information Screen : The source for accessing all vehicle information and options.



About Screen : Feedback screen for interface software information.

- Helpful information for troubleshooting.

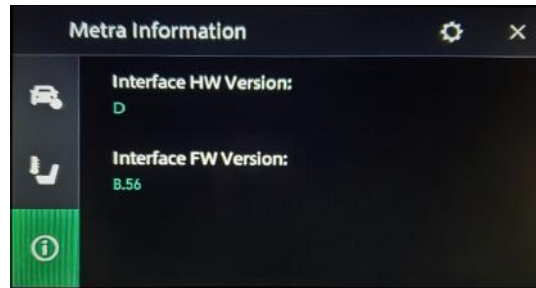



AXPIO-SIL2

INSTALLATION INSTRUCTIONS



Having difficulties? We're here to help.



Contact our Tech Support line at:
386-257-1187



Or via email at:
techsupport@metra-autosound.com

Tech Support Hours (Eastern Standard Time)

Monday - Friday: 9:00 AM - 7:00 PM

Saturday: 10:00 AM - 5:00 PM

Sunday: 10:00 AM - 4:00 PM



**Metra recommends MECP
certified technicians**