

# 30" Series 7 Contemporary Compact Convection-Speed Oven

Series 7 | Contemporary

Stainless Steel



The speed of microwave cooking with the versatility of convection oven technology, designed for perfect pairing with other companion products such as a steam oven or warming drawer.

- Generous 1.7 cu ft capacity, with four shelf positions
- With four microwave-only functions, 14 traditional oven functions, and four combination functions
- Guided cooking makes it simple to navigate cooking processes

- Wi-Fi enabled and works with the SmartHQ™ app for remote control and notifications

## DIMENSIONS

Height	18 "
Width	29 15/16 "
Depth	22 1/4 "

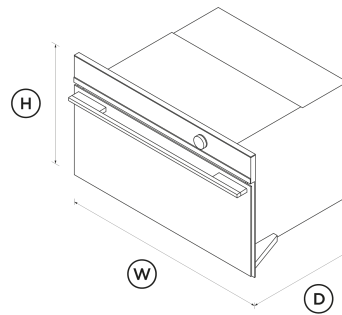

## FEATURES & BENEFITS

### Cooking flexibility

Choose from 19 cooking modes including True Convection and Broil. With both microwave and convection oven technology in the same oven, you have more flexibility for your culinary creations.

**Cook with confidence**

The screen provides an intuitive guided cooking experience that helps to deliver perfect results, whether you've been cooking all your life or are just starting out.

### Sized to suit

As a companion product this microwave oven is designed to be placed almost anywhere – fitting perfectly with a steam oven or other companion products to create a suite of kitchen appliances at your fingertips, and for your convenience.

### Easy to use

The intuitive display shows you all the information you need, allowing you to easily program in your desired cooking mode and duration.

### Multi-function flexibility

Each function has been tailored and tested to ensure perfect defrosting, heating and cooking. Use the included Wired Temperature Sensor to precisely monitor cooking in real time.

### Safe and sound

The CoolTouch door is safe to touch from the outside, protecting your hands and the surrounding cabinetry.

## SPECIFICATIONS

### Accessories (included)

Chromed shelf runners	•
Glass tray	1
Grill rack	1 set
Step down wire shelf	1
Wire shelf	1
Wired temperature sensor	1

### Capacity

Shelf positions	<b>4</b>
Total capacity	<b>1.73 L</b>
Usable capacity	<b>1.34 cu ft</b>

- Soft close doors
- True convection oven
- Turned stainless steel dials with illuminated halos

- Automatic sensor cooking

**Cleaning**

- Acid resistant graphite enamel
- Drying cycle
- Easy to clean interior
- Removable shelf runners

**Functions**

- Aero Broil
- Aero Broil + Microwave
- Aero™ Bake
- Air fry
- Bake
- Defrost
- Maxi Broil
- Maxi Broil + Microwave
- Microwave cooking
- Pastry Bake
- Pizza bake
- Popcorn
- Quick start
- Roast
- Roast + Microwave
- Slow cook
- True Aero
- True Aero + Microwave
- Vent bake

**Power requirements**

Amperage	<b>20 A</b>
Supply frequency	<b>60 Hz</b>
Supply voltage	<b>208 / 240 V</b>

**Controls**

- Adjustable audio and display settings
- Audio feedback
- Automatic cooking/minute timer
- Automatic pre-set temperatures
- Celsius/Fahrenheit temperature
- Delay start
- Dial with illuminated halo
- Electronic capacitive touch controls
- Electronic clock
- Electronic oven control
- Guided cooking by food type and recipes
- Halogen lights
- LED display
- Microwave timer
- Multi-language display **true**
- Push-to-open drawer
- Sabbath mode with Star K certification
- Smart appliance

**Performance**

- ActiveVent™ system
- AeroTech™ technology
- Automatic rapid pre-heat

**Product dimensions**

Depth	<b>22 1/4 "</b>
Height	<b>18 "</b>
Width	<b>29 15/16 "</b>

SKU	<b>82707</b>
-----	--------------

The product dimensions and specifications in this page apply to the specific product and model. Under our policy of continuous improvement, these dimensions and specifications may change at any time. You should therefore check with Fisher & Paykel's Customer Care Centre to ensure this page correctly describes the model currently available. © Fisher & Paykel Appliances Ltd 2020

**Other product downloads available at fisherpaykel.com**

- [↓](#) 2D-DWG Combination Microwave Oven
- [↓](#) 2D-DXF Combination Microwave Oven
- [↓](#) Service & Warranty
- [↓](#) Installation Guide EN
- [↓](#) Installation Guide FR
- [↓](#) Installation Guide SP

- ↓ Planning Guide EN - Contemporary 30" Built-in Ovens and Companions
- ↓ Planning Guide FR - Contemporary 30" Built-in Ovens and Companions
- ↓ Planning Guide SP - Contemporary 30" Built-in Ovens and Companions
- ↓ Revit 20 Convection Speed Oven
- ↓ User Guide EN
- ↓ User Guide FR
- ↓ User Guide SP

**Where applicable:**

All appliances use energy, and energy usage typically generates carbon emissions. **Fisher & Paykel Appliances' In-use Energy Carbon Emissions Estimate** indicates carbon emissions from a product's in-use energy. This is calculated either annually or per cycle, using the product's market-specific energy label energy consumption data multiplied by the carbon emissions factor for energy in your country or region.

Our In-use Energy Carbon Emissions Estimate is designed to assist customers in making informed purchasing decisions when comparing different Fisher & Paykel products. For example, a heat pump dryer typically has a lower In-use Energy Carbon Emissions Estimate than a vented dryer.



**A PEACE OF MIND SALE**  
**24 Hours 7 Days a Week Customer Support**  
T 1.888.936.7872 W [www.fisherpaykel.com](http://www.fisherpaykel.com)