

30" JennAir® RISE™ Induction Slide-In Range

JIS1450ML



Features

Magnetic Induction

The precision of gas with the minimalist appeal of glass tap touch controls. The powerful cooktop directly heats just the cookware, leaving the area surrounding the elements cool to the touch.

True Convection

Steady heat from a third element behind the whirling fan ensures circulation around every rack. Flaunt your cooking prowess with mouthwatering, flaky pastries and irresistible roasts.

Assisted Cooking

By selecting Assisted Boil, Simmer or Melt, the optimal power level is adjusted for you to help bring water to a boil, simmer foods or melt delicate ingredients.

Emotive Controls

Striking and inviting controls with LED lighting unleash performance at your touch.

Bridge Function

Combine two elements with the Bridge Function to create an expanded cooking zone for larger cookware, like braisers and griddles.

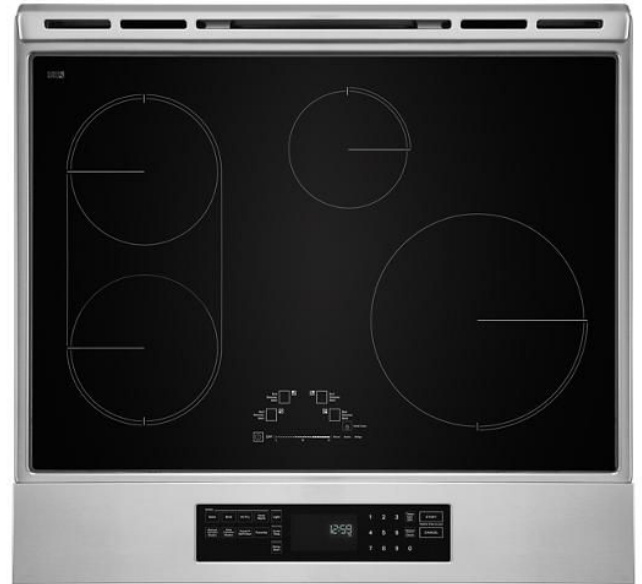

Product Details

Dimensions	29 7/8"W x 36 3/4"H x 26 3/16"D
Cutout Dimensions	30"W x 36"H x 24" (base cabinet)
Finish	RISE™ Design Expression
Capacity	6.4 Cu Ft
Cooktop Specs	L Front 1850W/3000W _(boost) L Rear 1850W/3000W _(boost) R Front 2600W/3600W _(boost) R Rear 1400W/2200W _(boost)

Accessories

W10655450	Stainless Steel Backsplash
W10675028	Trim Kit, Stainless Steel
W10655449	Backsplash, Black
W10675026	Trim Kit, Black
W10655448	Backsplash, White
W10675027	Trim Kit, White

30" JennAir® RISE™ Induction Slide-In Range

JIS1450ML



Electrical

- This range is manufactured with a 4-wire power supply cord rated at 240 V, 40 A, rated at 194°F (90°C) and investigated for use with this range.

Range Rating*		Specified Rating of Power Supply Cord Kit and Circuit Protection
120/240 V	120/208 V	Amps
8.8 - 16.5 kW	7.8 - 12.5 kW	40 or 50**
16.6 - 22.5 kW	12.6 - 18.5 kW	50

*The NEC calculated load is less than the total connected load listed on the model/serial/rating plate.

**If connecting to a 50 A circuit, use a 50 A rated cord with kit. For 50 A rated cord kits, use kits that specify use with a nominal 1³/₈" (34.9 mm) diameter connection opening.

- When a 4-wire, single phase 240 V, 60 Hz., AC only electrical supply is available, a 40 A minimum circuit protection is required on 30" (76.2 cm) ranges, fused on both sides of the line.
- A time-delay fuse or circuit breaker is recommended.
- This range is equipped with a UL or CSA International Certified Power Cord intended to be plugged into a standard 14-50R wall receptacle. Be sure the wall receptacle is within reach of range's final location.

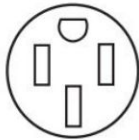

- Do not use an extension cord.

Induction Cookware

POTS AND PANS

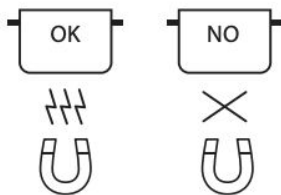

Only use pots and pans made from ferromagnetic material which are suitable for use with induction cooktop:

- Enameled steel.
- Cast iron
- Stainless steel designed for induction cooktops.

Cutout Dimensions

Slide-In Cutout

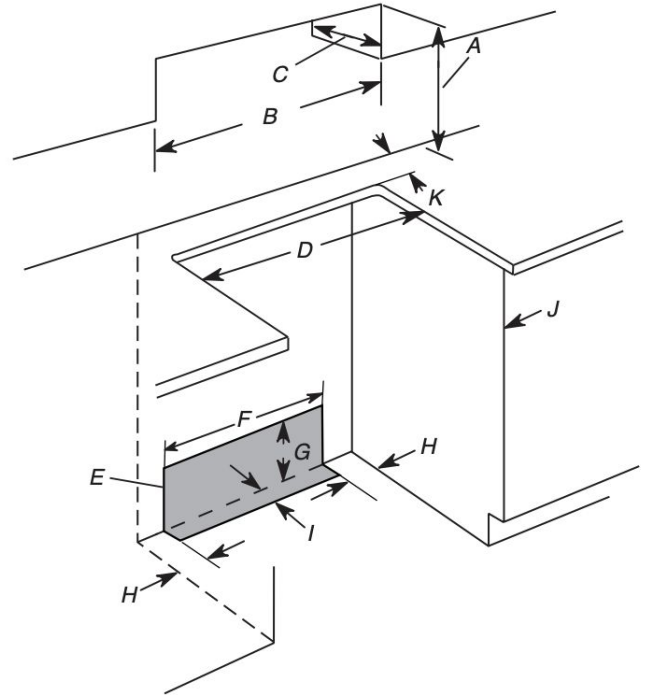

- A. For minimum clearance to top of cooktop, see NOTE*.
- B. 30" (76.2 cm) minimum opening width
- C. 13" (33 cm) maximum upper cabinet depth
- D. 30" (76.2 cm) minimum opening width
- E. The shaded area is recommended for installation of rigid gas pipe and grounded outlet.
- F. 1³/₈" (33.3 cm)
- G. 7¹¹/₁₆" (19.5 cm)
- H. 4¹³/₁₆" (12.2 cm)
- I. 3¹¹/₁₆" (9.4 cm) plus measurement of M
- J. Cabinet door or hinges should not extend into the cutout.
- K. Remaining counter depth should not exceed 2¹/₄" (5.7 cm).

Cabinet Dimensions

Countertop Depth	25"
Base Cabinet Depth	24"
Countertop Height	36"

Resources

[Owner's Manual](#)

[Air Fry Guide](#)

[Quick Start Guide](#)

[Warranty](#)